

CSE466 Lab 6-9

Note: PD3, PD4, and PD5 must be set correctly for proper operation. See MCP2120 datasheet.

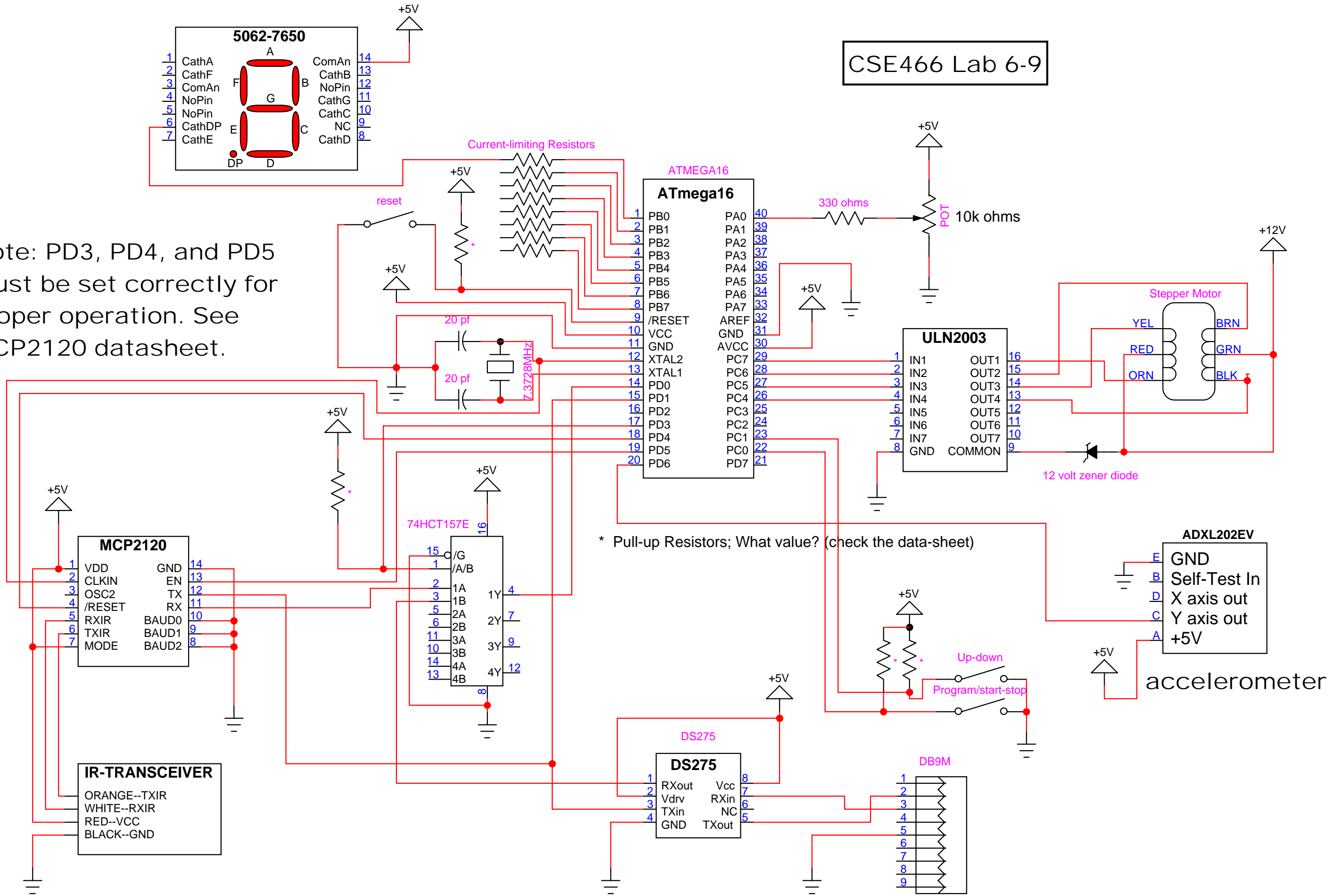

* Pull-up Resistors; What value? (check the data-sheet)