

### 3. Displays and framebuffers

1

### Reading

#### Required

- ♦ Angel, pp.19-31.
- ♦ Hearn & Baker, pp. 36-38, 154-157.

#### Optional

- ♦ Foley et al., sections 1.5, 4.2-4.5
- ♦ I.E. Sutherland. Sketchpad: a man-machine graphics communication system. *Proceedings of the Spring Joint Computer Conference*, p. 329-346, 1963.
- ♦ T.H. Myer & I.E. Sutherland. On the design of display processors. *Communications of the ACM* 11(6): 410-414, 1968.

2

### History

- ♦ Whirlwind Computer - MIT, 1950
  - CRT display
- ♦ SAGE air-defense system - middle 1950's
  - "Whirlwind II"
  - light pens
- ♦ Sketchpad - 1963, Ivan Sutherland
  - first interactive graphics system
  - constraint-based
  - interaction techniques for choosing, pointing, drawing
  - data structures for replicating components

3

### Modern graphics systems

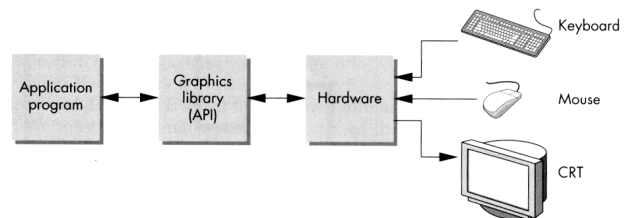

Current graphics systems consist of:

- An application, which talks to a...
- Graphics library (e.g., OpenGL or Direct3D), which talks to the...
- Graphics hardware

The graphics hardware can do a lot of fancy work these days. At a minimum, it contains a framebuffer to drive a display...

4

## Cathode ray tubes (CRTs)

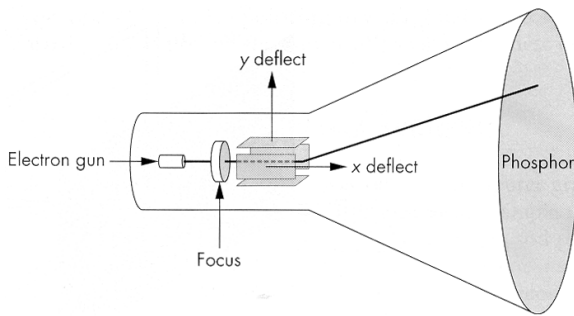

Consists of:

- ◆ electron gun
- ◆ electron focusing lens
- ◆ deflection plates/coils
- ◆ electron beam
- ◆ anode with phosphor coating

5

## CRTs, cont.

Electrons “boil off” the heated cathode and shoot towards the anode. Electrons striking the phosphors create light through:

- ◆ fluorescence (fraction of usec)
- ◆ phosphorescence (10 to 60 usec)

Different phosphors have different:

- ◆ color
  - red: europium yttrium vanadate
  - green: zinc cadmium sulfide
  - blue: zinc sulfide
- ◆ persistence (as long as a few seconds)

The image must be **refreshed** to avoid **flicker**, typically at least 60 Hz, though 72 Hz is easier on the eyes.

6

## Calligraphic displays

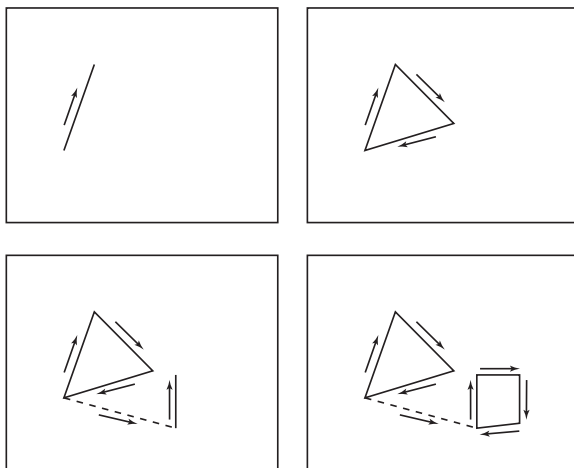

Also called **vector displays**, **stroke displays**, or **random-scan displays**.

Used by:

- ◆ Sutherland’s Sketchpad
- ◆ Asteroids video game
- ◆ Oscilloscopes

7

## Raster displays

**ras.ter**, from radere, “to scrape”

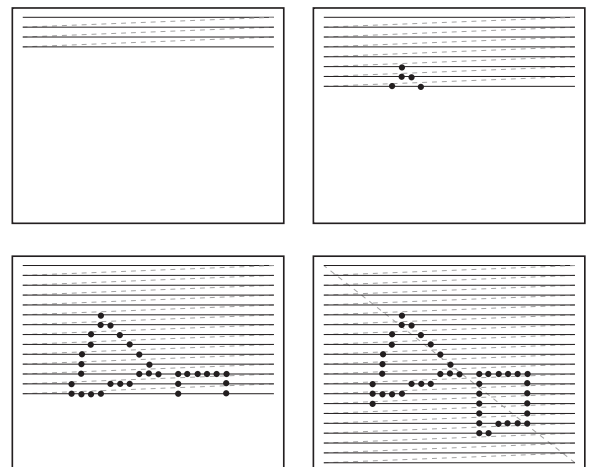

Electron beam traces over screen in **raster scan order**.

- ◆ Each left-to-right trace is called a **scan line**.
- ◆ Each spot on the screen is a **pixel**.
- ◆ When the beam is turned off to sweep back, that is a **retrace**, or a **blanking interval**.

8

## Framebuffer

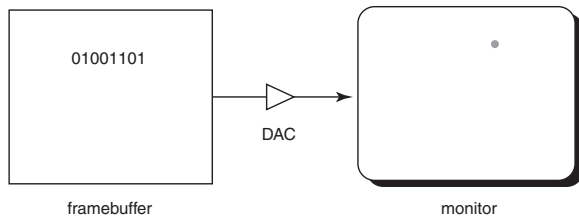

Intensity of the raster scan beam is modulated according to the contents of a **framebuffer**.

Each element of the framebuffer is associated with a single **pixel** on the screen.

## Resolution

The display's "**resolution**" is determined by:

- ◆ number of scan lines
- ◆ number of pixels per scan line
- ◆ number of bits per pixel

Resolution is used here to mean total number of bits in a display. It should really refer to the resolvable dots per unit length...

Examples:

Bitmapped display	960 x 1152 x 1b	1/8 MB
NTSC TV	640 x 480 x 16b	1/2 MB
Color workstation	1280 x 1024 x 24b	4 MB
Laser-printed page		
300 dpi	8.5 x 11 x 300 <sup>2</sup> x 1b	1 MB
1200 dpi	8.5 x 11 x 1200 <sup>2</sup> x 1b	17 MB
Film	4500 x 3000 x 30b	50 MB

## Aspect ratio

**Frame aspect ratio** = horizontal / vertical size

TV	4 : 3
HDTV	16 : 9
Letter-size paper	8.5 : 11 (about 3 : 4)
35mm film	3 : 2
Panavision	2.35 : 1

**Pixel aspect ratio** = pixel width / pixel height

- ◆ nowadays, this is almost always 1.

## Color CRT monitors

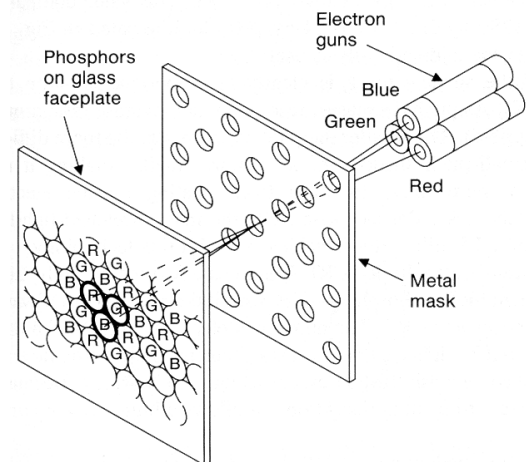

Many color monitors employ **shadow mask** technology. The variety depicted above:

- ◆ uses **triads** of red, green, and blue phosphors at each pixel
- ◆ uses three electron guns, one per color
- ◆ **shadow mask** used to make each kind of phosphor only "visible" from one gun

These are also known as **RGB monitors**.

## Color Trinitron CRT's

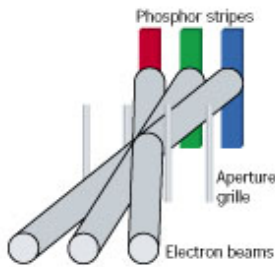

A competing technology is called Trinitron (by Sony):

- ♦ uses vertical stripes of red, green, and blue phosphors at each pixel
- ♦ uses three electron guns, one per color
- ♦ uses an **aperture grille** to make each kind of phosphor only “visible” from one gun

You can see two horizontal lines at about  $\frac{1}{4}$  and  $\frac{3}{4}$  of the way up the screen on Trinitron displays. Why?

13

## Liquid Crystal Displays

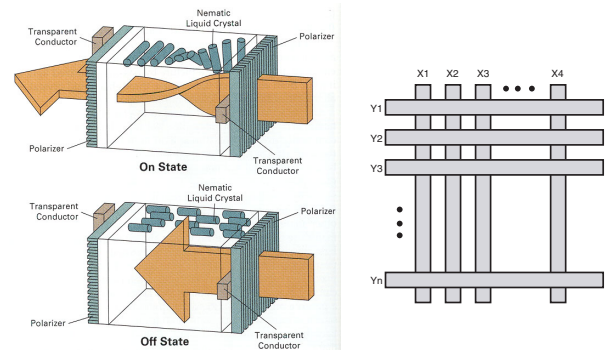

Laptops typically use **liquid crystal displays (LCD's)**.

- ♦ Light enters a **vertical polarizer**
- ♦ **Nematic crystal** twists light based on applied voltage (more voltage, less twisting)
- ♦ Light passes through **horizontal polarizer**

Passive matrix displays use a matrix of electrodes to control the voltages. Problem: slow to switch, overflows.

Active matrix displays have a transistor at each cell. They use a faster switching crystal and transistors that hold charge and prevent overflow.

Color filters are used to get color display.

14

## Additive color mixing

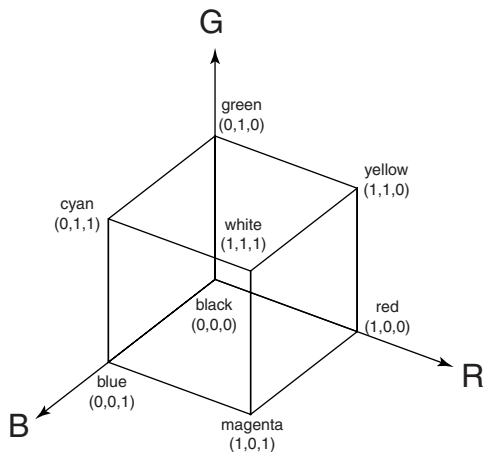

All colors on a monitor or LCD are produced using combinations of red, green, and blue.

A display that allows 256 voltage settings for each of R, G, and B is known as a **full-color system**.

The description of each color in framebuffer memory is known as a **channel**.

15

## Color tables

**Color tables** allow more color versatility when you only have a few bits per pixel. You get to select a small **palette** of from a large number of available colors.

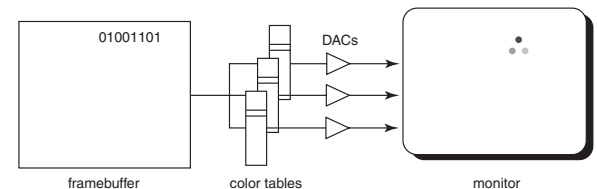

Each framebuffer element is now an index into the color table, where the actual values of each channel are stored.

- ♦ Color table entries can be changed in software.

16

## RGB framebuffer

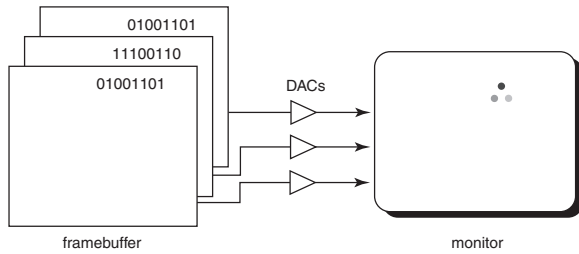

The term **true-color** is sometimes used to refer to systems which the framebuffer directly stores the values of each channel.

As memory prices have fallen, true-color has become fairly standard.

17

## Anatomy of an RGB image

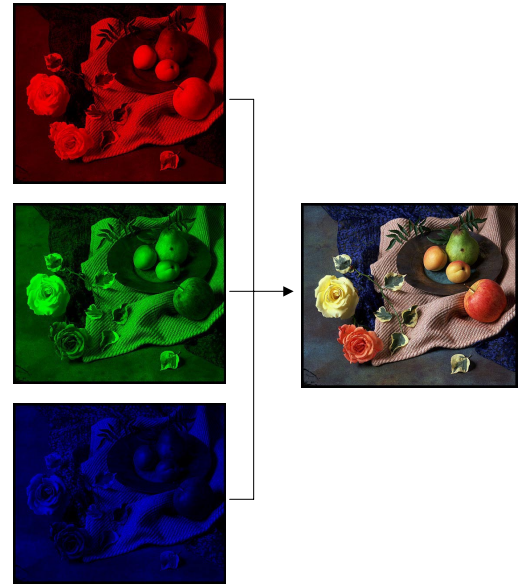

18

## Color tables on 24-bit systems

Even full-color systems often use color tables. In this case, there is a separate color table for each 8 bit channel.

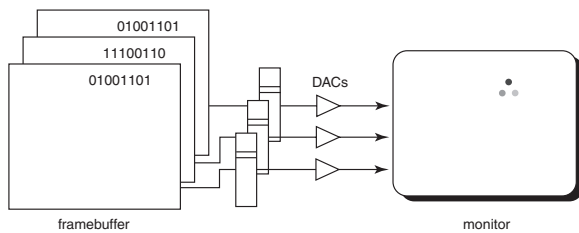

**Q:** Why would you want this capability?

19

## Double-buffering

**Q:** What happens when you write to the framebuffer while it is being displayed on the monitor?

**Double-buffering** provides a solution.

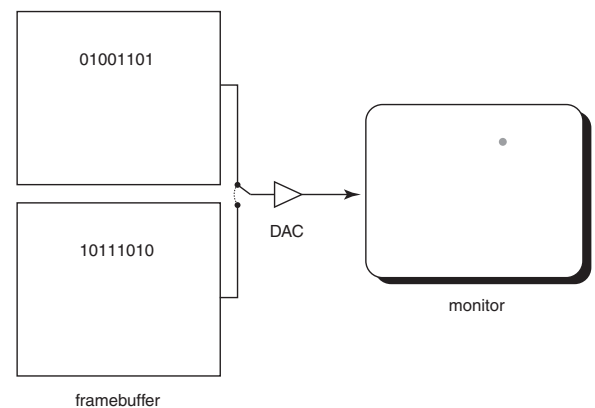

20

## Summary

Here's what you should take home from this lecture:

- ◆ All of the **boldfaced terms**.
- ◆ Sketchpad (1963) was the first interactive graphics system.
- ◆ The basic components of black-and-white and color CRTs.
- ◆ Raster vs. calligraphic displays.
- ◆ The principle operation for an LCD display.
- ◆ Computing screen resolution & framebuffer size.
- ◆ The correspondence between elements of framebuffer memory and pixels on-screen.
- ◆ How color tables and double-buffering work.