

Exceptions and Interrupts

- Normal operation of a computer evaluates instructions one after another without pause
- What happens in unusual conditions? Two kinds:
 - Exceptions are unexpected events in execution of the instruction, i.e. mainly errors
 - Interrupts are unexpected changes in control flow caused by events outside the processor, i.e. mainly IO devices
- This distinction is slightly artificial ... there are other views
 - They're all interrupts
 - Interrupts are external; exceptions are internal; syscall?

Handling Interrupts

- The executing program reports the exception/interrupt; the OS handles it
- Two pieces of information are needed for the OS to help: What happened and where.
 - Add a “Cause” register to store the reason of except/interrupt
 - Add a Exception PC (EPC) register to store the address of the offending instruction
- Set up a means of returning to the operating system
 - Force a branch to fixed memory address (where OS handler code resides)
- Vectored Interrupts are alternative to “Cause”

Multicycle with Interrupt Handling Capability

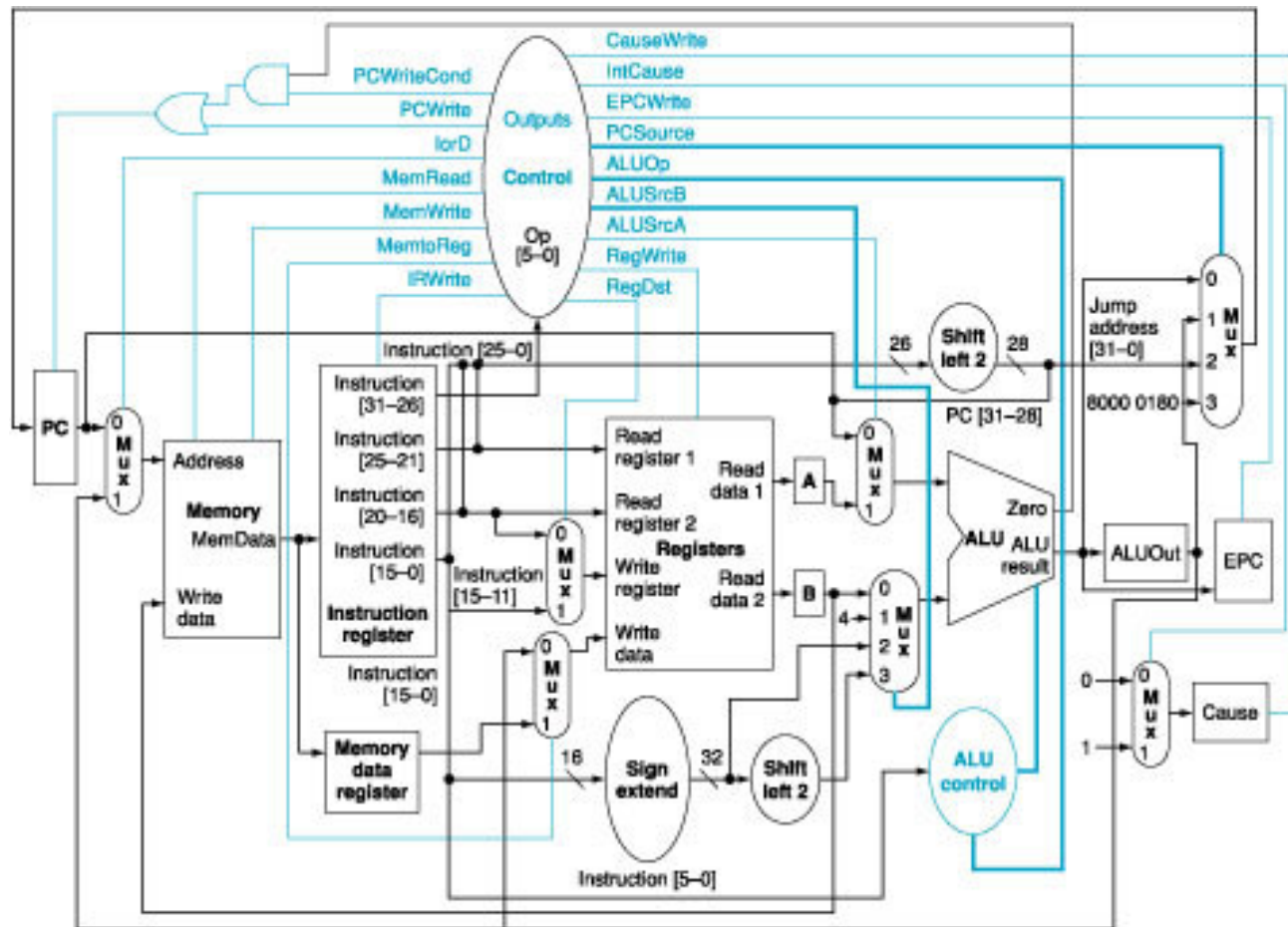

Revised Control

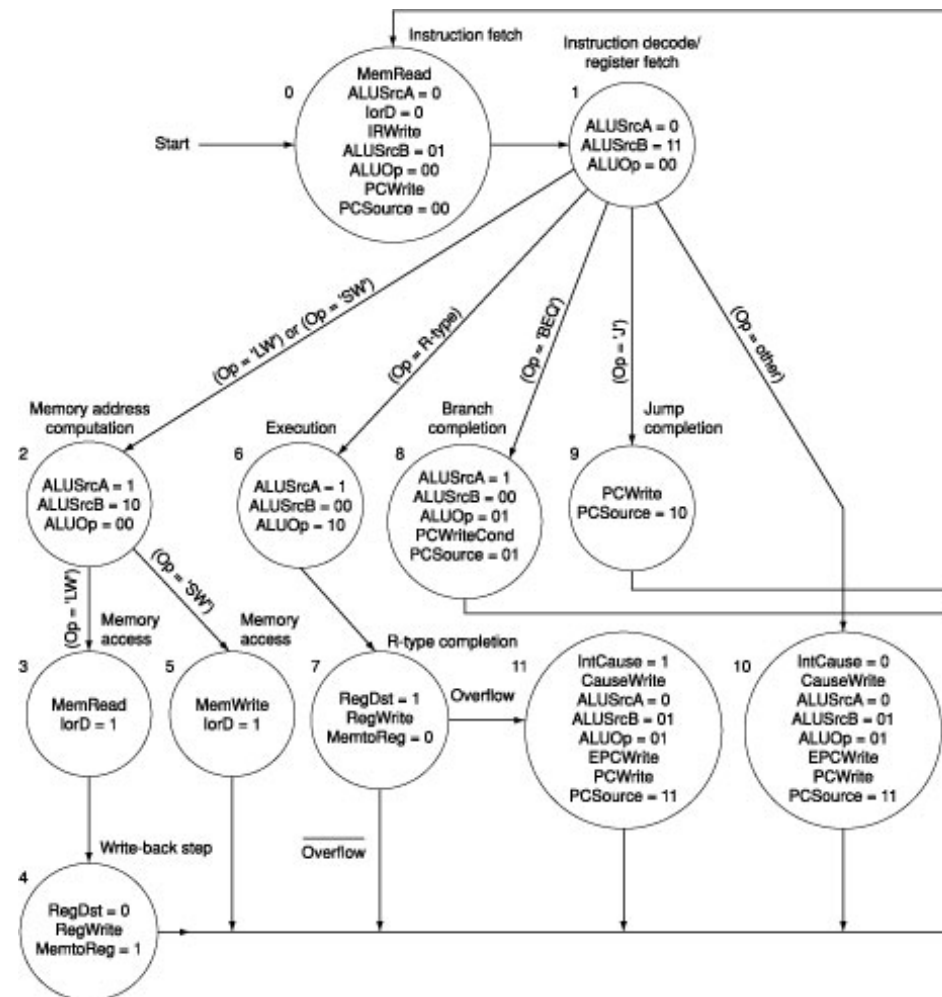

Review