

# Lecture 4: Truth Tables and More Boolean Functions

CSE 370, Autumn 2007  
Benjamin Ylvisaker

---

## Last Lecture's Daily Quiz

- In 2's complement, the number of bits matters
  - 110 is not a 4-bit 2's comp. number
  - 0110 is
- "Flip the bits" means replace 1's with 0's and 0's with 1's in each bit position
- Remember to add 1

# Where We Are

- Last lecture: Boolean algebra
- This lecture: Truth tables and lots of “useful” Boolean functions
- Next lecture: Canonical forms
- Homework 1 due today. Homework 2 out
- In the midst of lab 1
  - Slight modification of lab late policy

## Truth Tables (0-7)

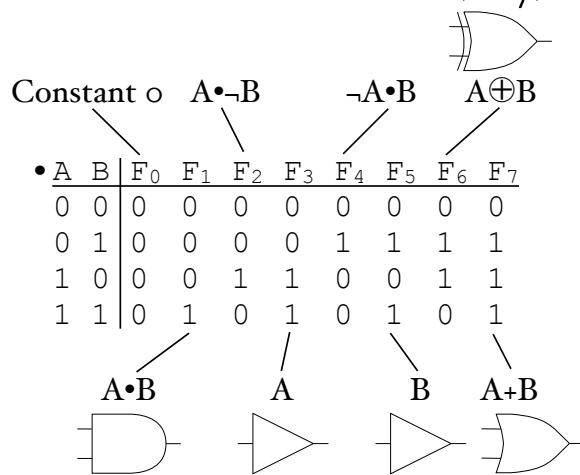

# Truth Tables (8-15)

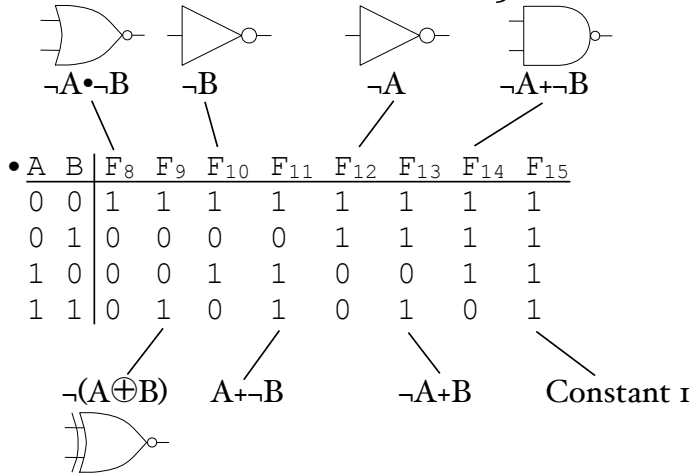

# Proof by Truth Table

A	B	$\overline{A}$	$\overline{B}$	A+B	$\overline{A+B}$	$\overline{A \cdot B}$	A · B	$\overline{A \cdot B}$	$\overline{A+B}$
0	0	1	1	0	1	1	0	1	1
0	1	1	0	1	0	0	0	1	1
1	0	0	1	1	0	0	0	1	1
1	1	0	0	1	0	0	1	0	0

# Comparing Two Numbers

A	B	C	D	F
0	0	0	0	0
0	0	0	1	0
0	0	1	0	0
0	0	1	1	0
0	1	0	0	1
0	1	0	1	0
0	1	1	0	0
0	1	1	1	0

A	B	C	D	F
1	0	0	0	1
1	0	0	1	1
1	0	1	0	0
1	0	1	1	0
1	1	0	0	1
1	1	0	1	1
1	1	1	0	1
1	1	1	1	0

# Full Adder

$$S = A\bar{B}\bar{C} + \bar{A}\bar{B}C + ABC + \bar{A}B\bar{C}$$

A	B	C <sub>in</sub>	S	C <sub>out</sub>
0	0	0	0	0
0	0	1	1	0
0	1	0	1	0
0	1	1	0	1
1	0	0	1	0
1	0	1	0	1
1	1	0	0	1
1	1	1	1	1

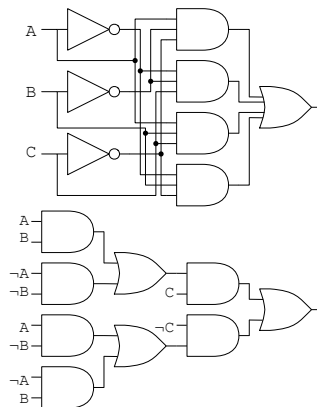

# Now You Try

$$F = \neg A + BC$$

A	B	C	F
0	0	0	
0	0	1	
0	1	0	
0	1	1	
1	0	0	
1	0	1	
1	1	0	
1	1	1	

# Now You Try

$$F = \neg A + BC$$

A	B	C	F
0	0	0	1
0	0	1	1
0	1	0	1
0	1	1	1
1	0	0	0
1	0	1	0
1	1	0	0
1	1	1	1

# Now You Try

$$F = \neg A + BC$$

A	B	C	F
0	0	0	1
0	0	1	1
0	1	0	1
0	1	1	1
1	0	0	0
1	0	1	0
1	1	0	0
1	1	1	1

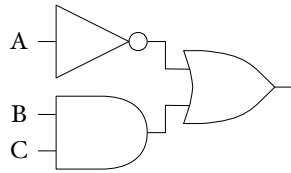

# Universal Gates

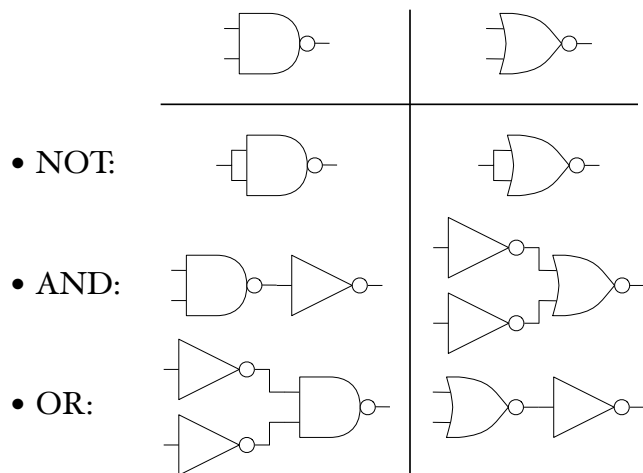

# Thank You for Your Attention

- Start looking at homework 2
- Continue reading the book