

CSEP 527

Computational Biology

<http://courses.cs.washington.edu/courses/csep527/18wi>

Larry Ruzzo
Winter 2018



UW CSE Computational Biology Group

He who asks is a fool for five minutes, but he who does not ask remains a fool forever.

-- Chinese Proverb

Tonight

Admin

Why Comp Bio?

The world's shortest Intro. to Mol. Bio.

Admin Stuff



Please do this
ASAP

CSE P527, Sp '16: Computational Biology (Professional Masters Program)

CSE Home

- Administrative
- Schedule & Reading
- HW0: Background
- Course Email
- Subscription Options
- Class List Archive
- GoPost BBoard

Homework 0

Lecture: [JHN 075](#) Th 6:30-9:20

Office Hours Location Phone
By appt. CSE 554 (206) 543-6290

TA: Daniel Jones, dcjones@cs.washington.edu By appt.

Course Email: multi_csep527a_sp16@uw.edu. Staff announcements are posted here. Please direct student/staff Q&A about homework to this email address. Enrolled students are as well, but probably should [change their email address](#) to [csep527@uw.edu](#). Messages are automatically archived.

Discussion Board: Also feel free to use [Catalyst GoP](#) for discussion, work, etc.

Catalog Description: Introduction to the use of computational methods for understanding biological systems at the molecular level. Topics include sequence analysis, structure prediction, phylogenetics, motif discovery, expression analysis, and regulatory analysis. Prerequisites: MCMC, expectation-maximization, and basic programming.

Prerequisite: None

Credits: 4

Learning Objectives: The complete genome sequences of humans and other organisms is one of the largest volumes of data in the world. This data presents a challenge to scientists for decades to come, and the nature and scope of the problem motivates the development of new computational methods. The objective of this course is to understand the variety of computational problems and solutions that arise in this field. Students will learn to understand the context for the computational problems presented in the rest of the course. They will also learn how computational methods can be applied to solve problems in modern molecular biology. An important component of the course is the use of publicly available computational analysis tools and the development of new tools for the solution of these problems, as well as publicly available computational analysis tools and the development of new tools.

Course Format: This is a work-based (no exams). Homework will include programming, paper & pencil exercises and some online exercises.

Assignments: In general, assignments are due at or before the start of class on the assigned date. The occasional assignment may be due a few days later. Please contact me if you get in a bind this way.

Extra Credit: Assignments may include "extra credit" sections. These will enrich your understanding of the material, but are not required. Please do not start extra credit until the basics are complete.

Textbook: Richard Durbin, Sean R. Eddy, Anders Krogh and Graeme Mitchison, *Biological Sequence Analysis: Probabilistic Models of Biological Sequences*. (Available from [U Book Store](#), [Amazon](#), etc.) [Errata](#).

References: See [Schedule & Reading](#).

<http://courses.cs.washington.edu/courses/csep527/18wi>

Course Mechanics & Grading

Web

<http://courses.cs.washington.edu/courses/csep527/18wi>

Reading

In class discussion

Homeworks

reading blogs

paper exercises

programming

← Check web for 1st, ~~soon~~ **now**

No exams, but possible oversized last homework in lieu of final

Background & Motivation

Growth of GenBank (Base Pairs)

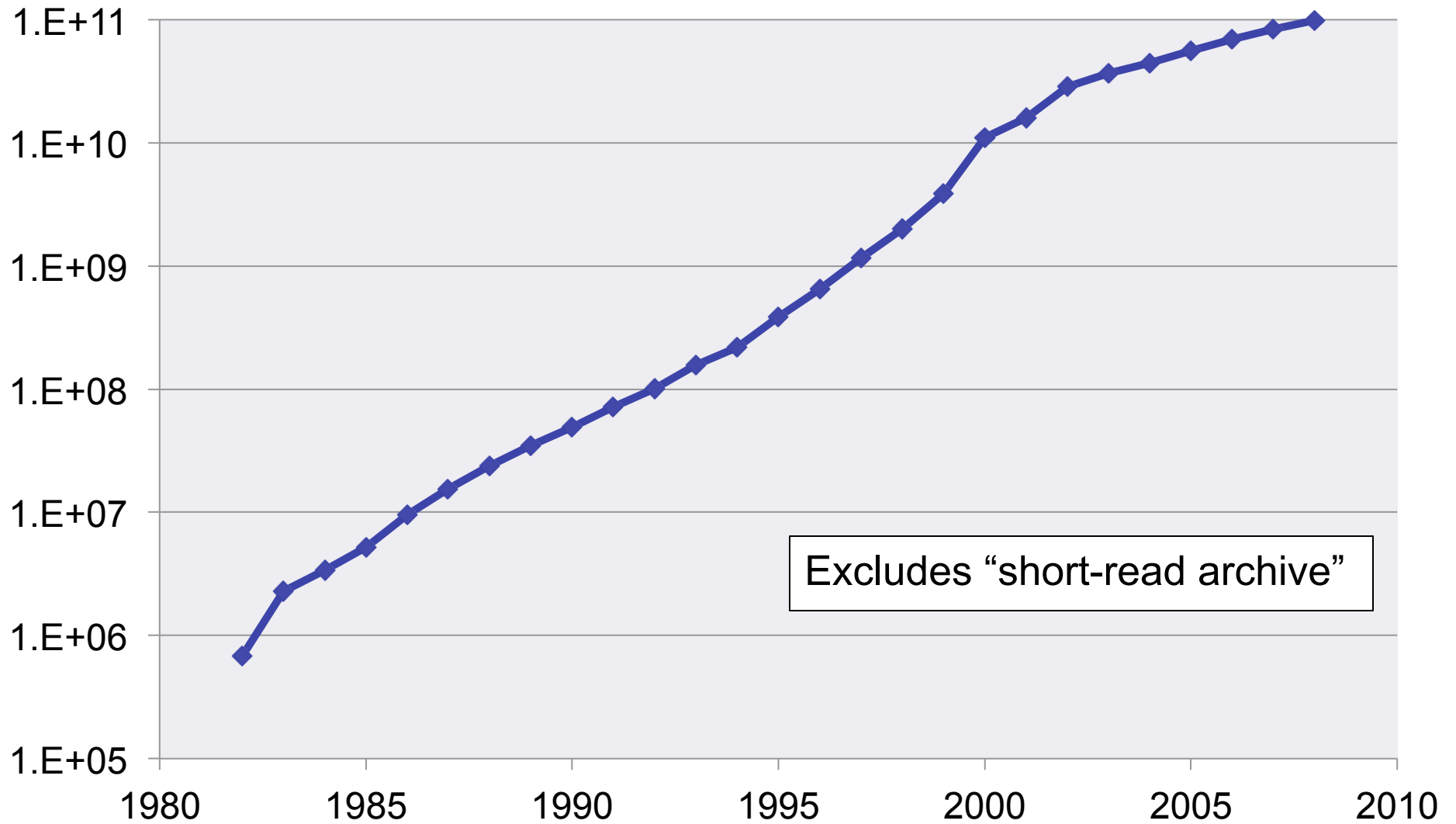

Source: <http://www.ncbi.nlm.nih.gov/Genbank/genbankstats.html>

SRA database growth

13,337,616,565,589,980 total bases
5,485,195,981,379,038 open access bases

13.3 peta-bases

Short Read Archive Growth

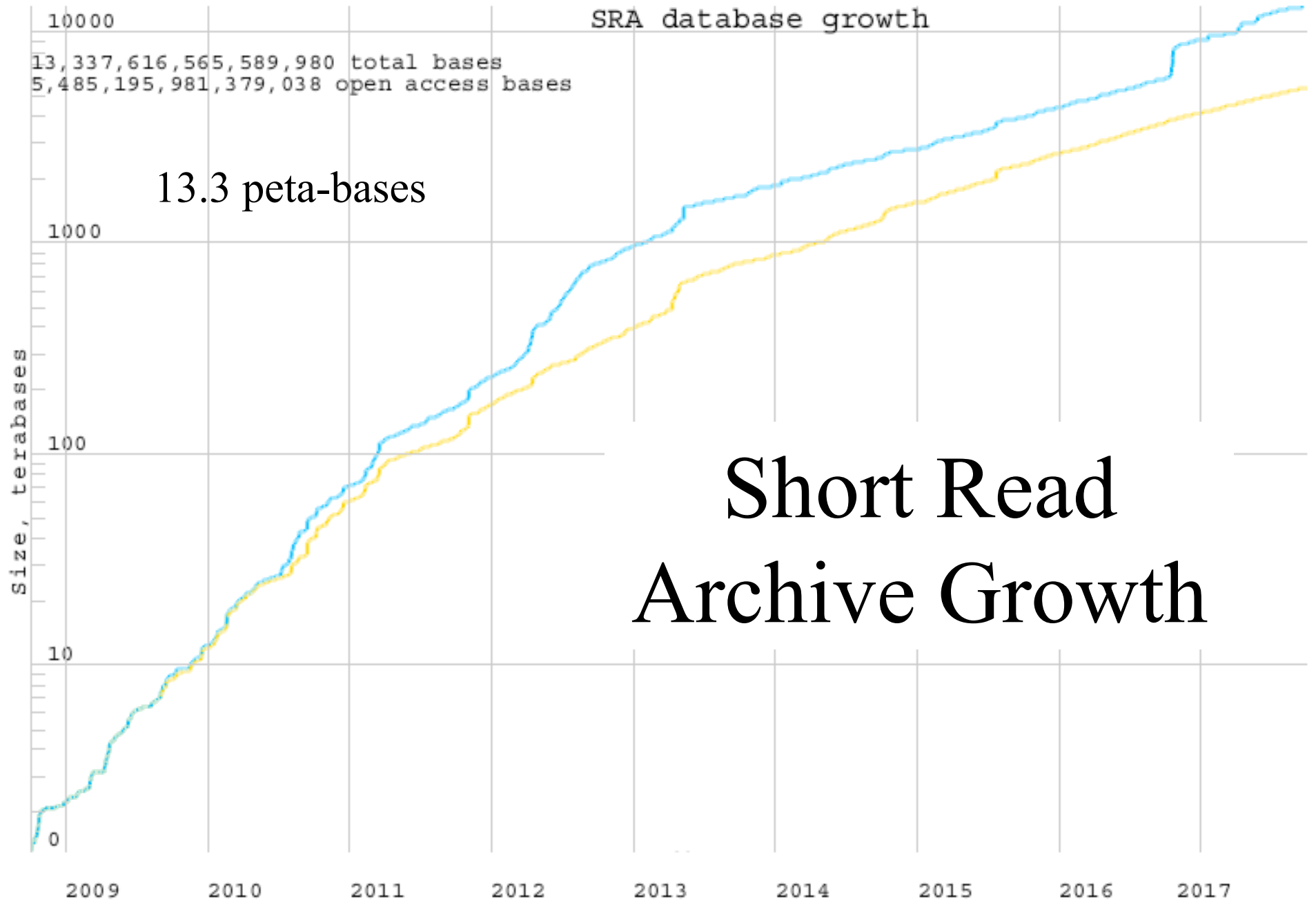

Total bases ———
Open access bases ———

<http://www.ncbi.nlm.nih.gov/Traces/sra/>

Cost per Genome

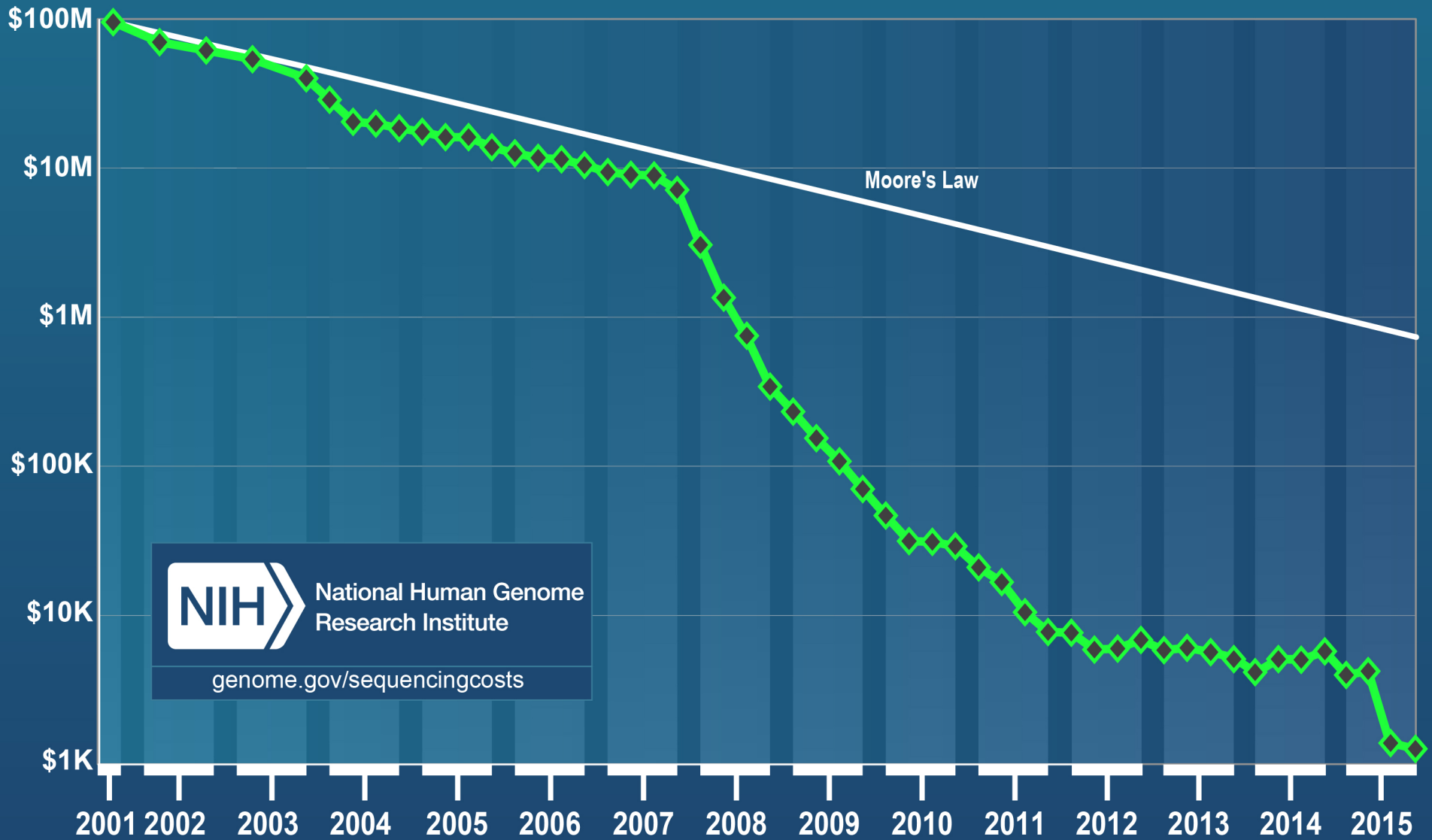

NIH National Human Genome Research Institute
genome.gov/sequencingcosts

<https://www.genome.gov/sequencingcostsdata/>

Modern DNA Sequencing

A table-top box the size of your oven (but costs a bit more ... ;-)
can generate
~100 billion BP of DNA seq/day; i.e.
= 2008 genbank,
= 30x your genome

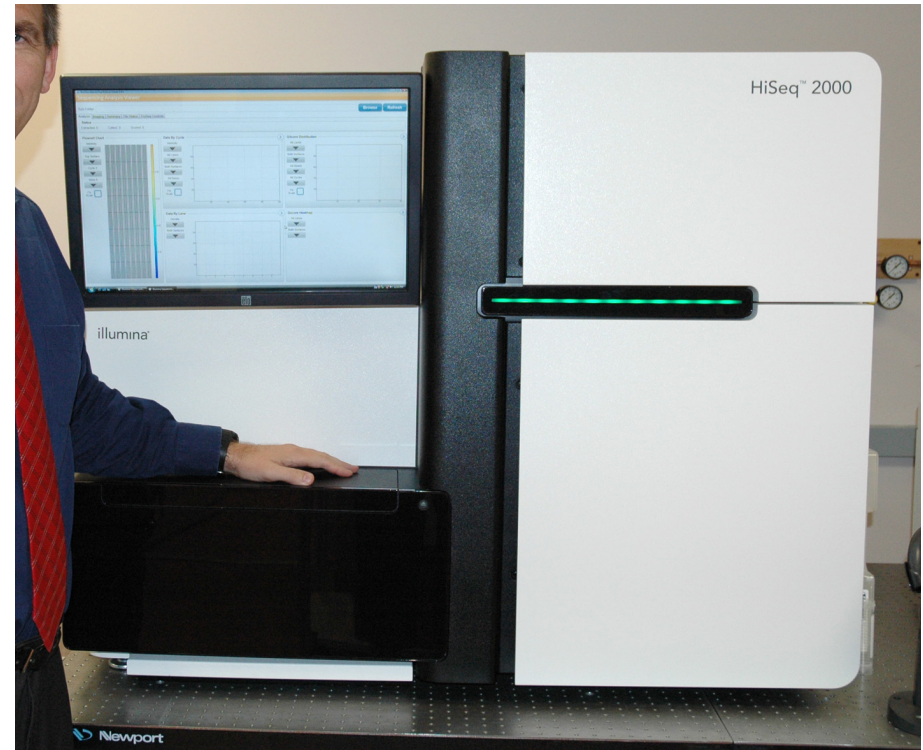



PERSPECTIVE

Big Data: Astronomical or Genomical?

Zachary D. Stephens¹, Skylar Y. Lee¹, Faraz Faghri², Roy H. Campbell², Chengxiang Zhai³, Miles J. Efron⁴, Ravishankar Iyer¹, Michael C. Schatz^{5*}, Saurabh Sinha^{3*}, Gene E. Robinson^{6*}

PLoS Biol 13(7): e1002195. doi:10.1371/journal.pbio.1002195

<http://127.0.0.1:8081/plosbiology/article?id=info:doi/10.1371/journal.pbio.1002195>

Fig 1. Growth of DNA sequencing.

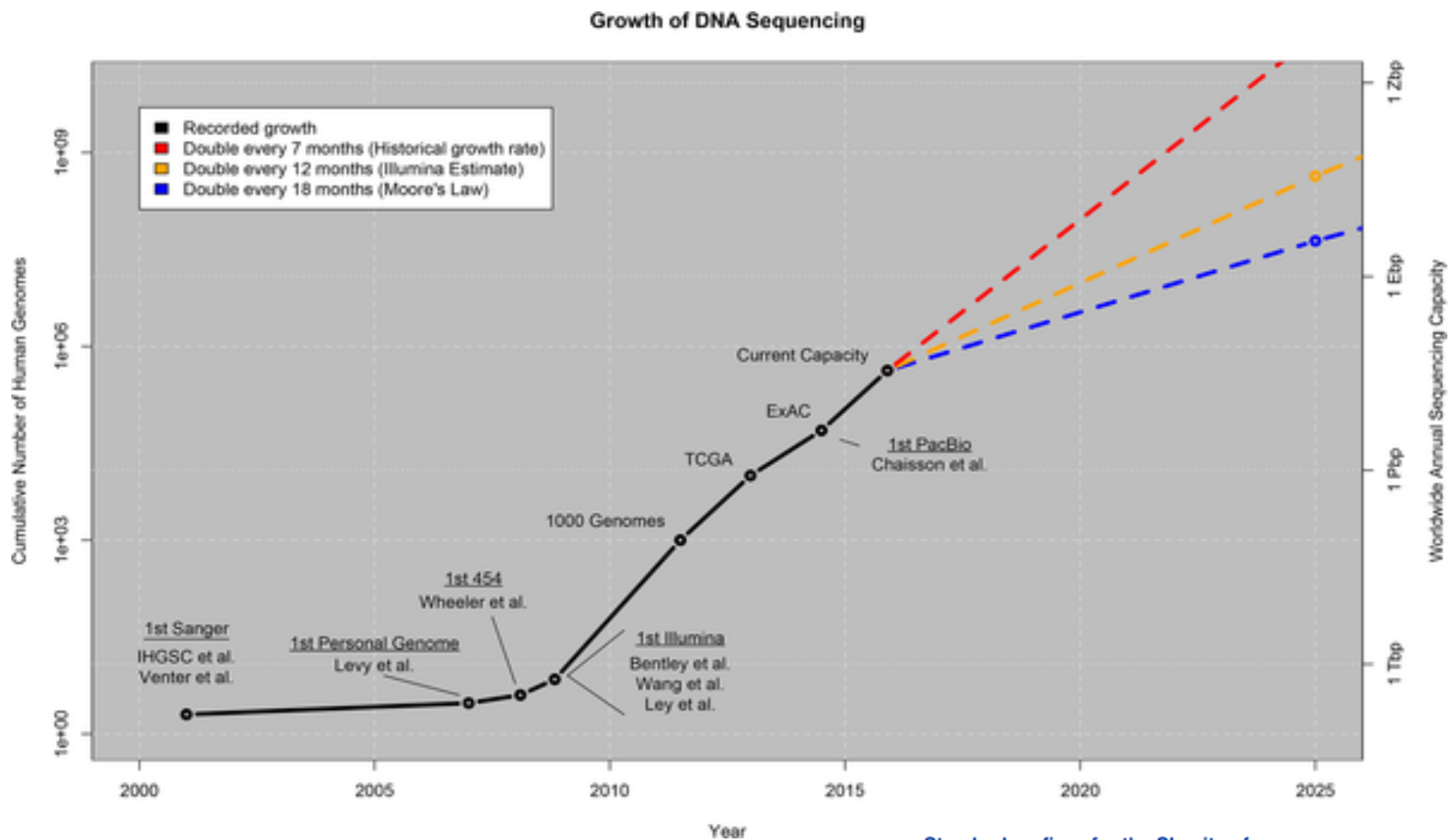

Stephens ZD, Lee SY, Faghri F, Campbell RH, Zhai C, et al. (2015) Big Data: Astronomical or Genomical?. PLoS Biol 13(7): e1002195. doi:10.1371/journal.pbio.1002195

<http://127.0.0.1:8081/plosbiology/article?id=info:doi/10.1371/journal.pbio.1002195>

Standard prefixes for the SI units of measure

Prefix name	deca	hecto	kilo	mega	giga	tera	peta	exa	zetta
Prefix symbol	da	h	k	M	G	T	P	E	Z
Factor	10 ⁰	10 ¹	10 ²	10 ³	10 ⁶	10 ⁹	10 ¹²	10 ¹⁵	10 ²¹

Table 1. Four domains of Big Data in 2025.

In each of four domains, projected annual storage and computing needs are presented across the data lifecycle.

Data Phase	Astronomy	Twitter	YouTube	Genomics
Acquisition	25 zetta-bytes/year	0.5–15 billion tweets/year	500–900 million hours/year	1 zetta-bases/year
Storage	1 EB/year	1–17 PB/year	1–2 EB/year	2–40 EB/year
Analysis	In situ data reduction	Topic and sentiment mining	Limited requirements	Heterogeneous data and analysis
	Real-time processing	Metadata analysis		Variant calling, ~2 trillion CPU hours
	Massive volumes			All-pairs genome alignments, ~10,000 trillion CPU hours
Distribution	Dedicated lines from antennae to server (600 TB/s)	Small units of distribution	Major component of modern user's bandwidth (10 MB/s)	Many small (10 MB/s) and fewer massive (10 TB/s) data movements

Stephens ZD, Lee SY, Faghri F, Campbell RH, Zhai C, et al. (2015) Big Data: Astronomical or Genomical?. PLoS Biol 13(7): e1002195. doi: 10.1371/journal.pbio.1002195

<http://127.0.0.1:8081/plosbiology/article?id=info:doi/10.1371/journal.pbio.1002195>

The Human Genome Project

```
1 gagccccggcc cggggggacgg gcggcgggat agcgggaccc cggcgcggcg gtgcgcttca
61 gggcgcagcg gcggccgcag accgagcccc gggcgcggca agagggcggcg ggagccggtg
121 gcggctcggc atcatgcgtc gagggcgtct gctggagatc gccctgggat ttaccgtgct
181 tttagcgtcc tacacgagcc atggggcgga cgccaatttg gaggctggga acgtgaagga
241 aaccagagcc agtcgggcca agagaagagg cgggtggagga cacgacgcgc ttaaaggacc
301 caatgtctgt ggatcacggt ataatgctta ctgttgccct ggatggaaaa ccttacctgg
361 cggaaatcag tgtattgtcc ccatttgccg gcattcctgt ggggatggat tttgttcgag
421 gccaaatatg tgcacttgcc catctgggtca gatagctcct tcctgtggct ccagatccat
481 acaacactgc aatattcgct gtatgaatgg aggtagctgc agtgacgatc actgtctatg
541 ccagaaagga tacataggga ctcactgtgg acaacctgtt tgtgaaagtg gctgtctcaa
601 tggaggaagg tgtgtggccc caaatcgatg tgcatgcact tacggattta ctggaccca
661 gtgtgaaaga gattacagga caggcccatg ttttactgtg atcagcaacc agatgtgcca
721 gggacaactc agcgggattg tctgcacaaa acagctctgc tgtgccacag tcggccgagc
781 ctggggccac ccctgtgaga tgtgtcctgc ccagcctcac ccctgccgcc gtggcttcat
841 tccaaatata cgcacgggag cttgtcaaga tgtggatgaa tgccaggcca tccccgggct
901 ctgtcaggga ggaaattgca ttaatactgt tgggtctttt gagtgcaaat gccctgctgg
961 acacaaactt aatgaagtgt cacaaaaatg tgaagatatt gatgaatgca gcaccattcc
1021 ...
```



The sea urchin *Strongylocentrotus purpuratus*

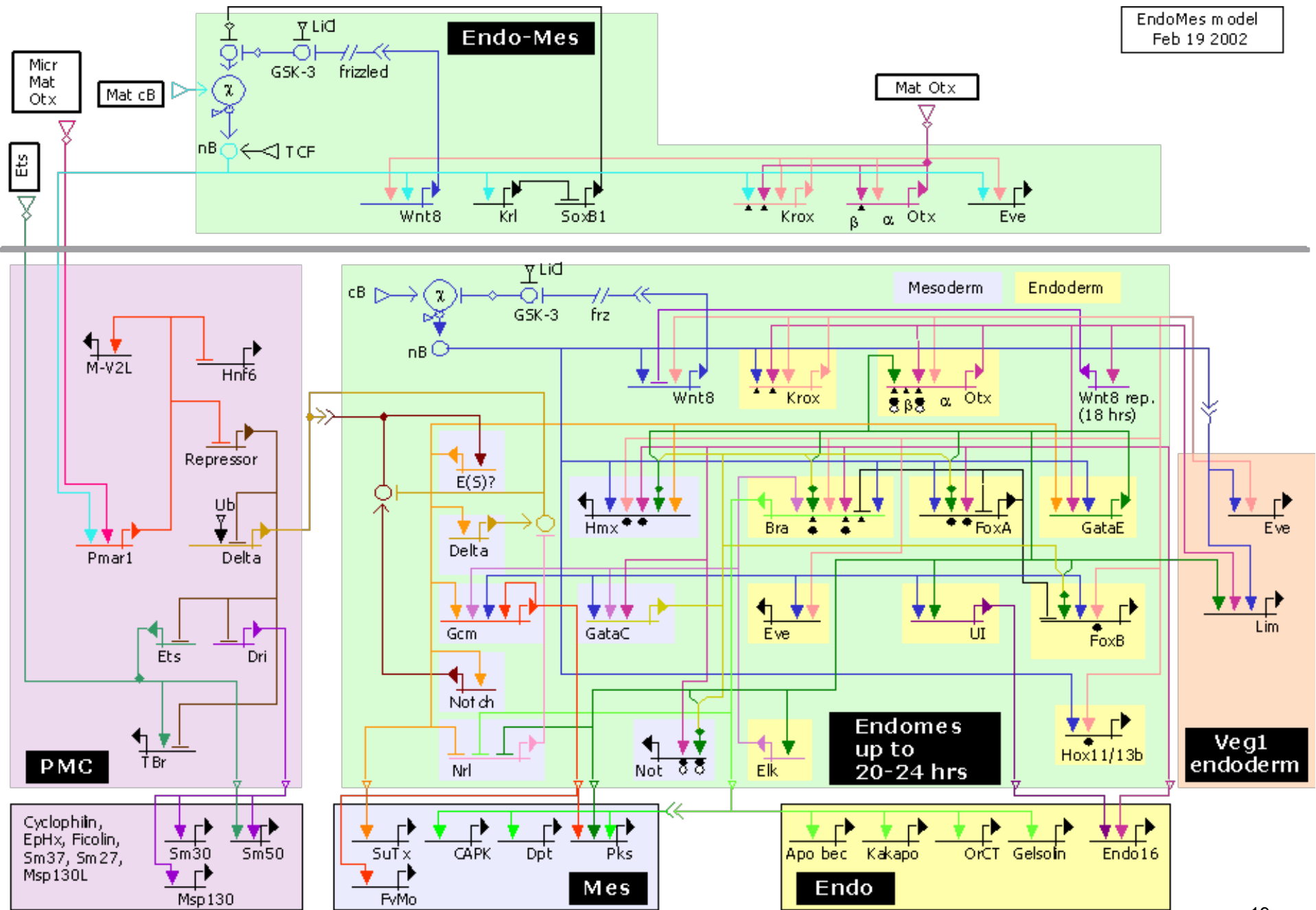

UCSC Genome Browser on Human Feb. 2009 (GRCh37/hg19) Assembly

move <<< << < > >> >>> zoom in 1.5x 3x 10x base zoom out 1.5x 3x 10x

chr11:17,741,110-17,743,678 2,569 bp.

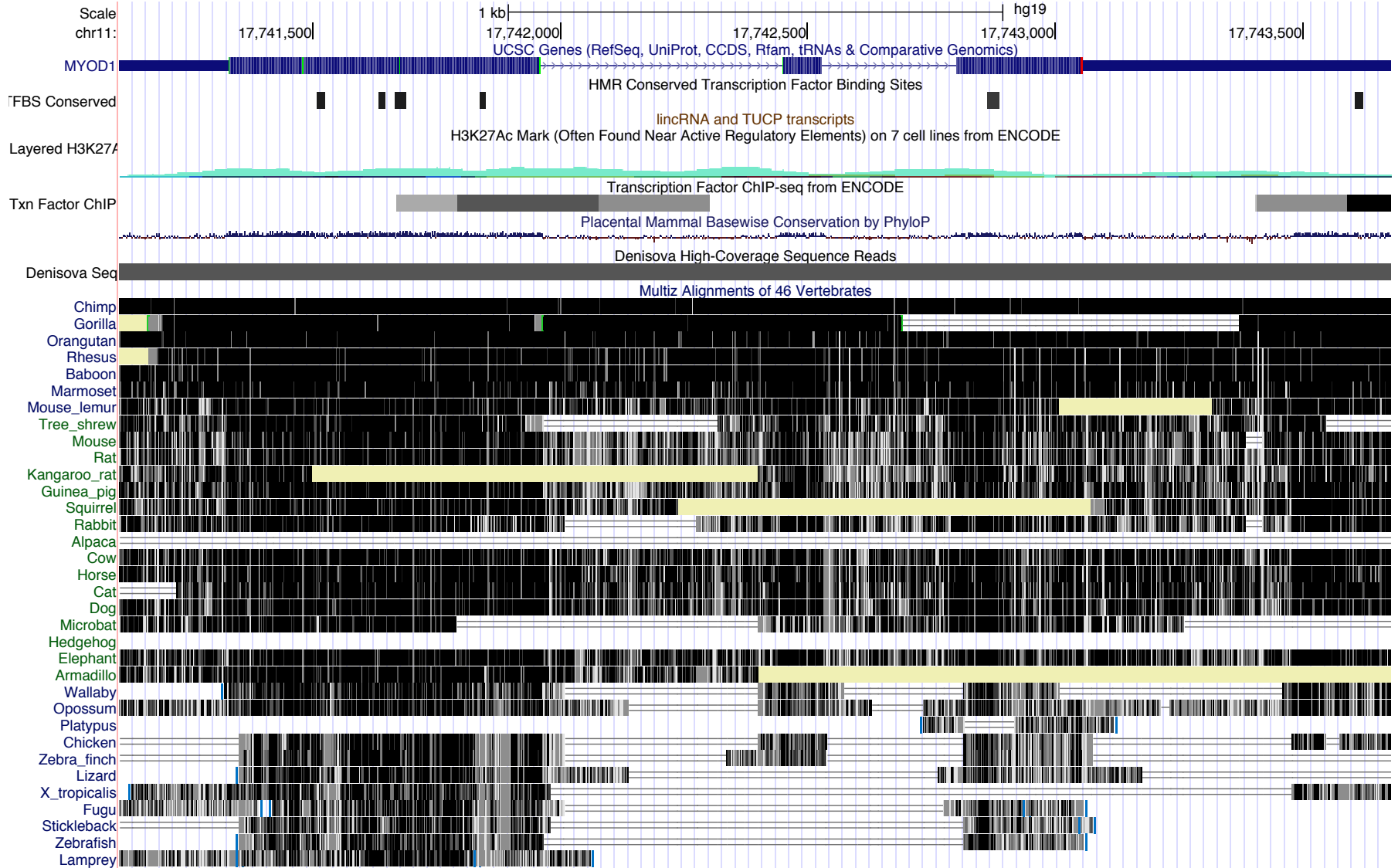

Goals

Basic biology

Disease diagnosis/prognosis/treatment

Drug discovery, validation & development

Individualized medicine

...

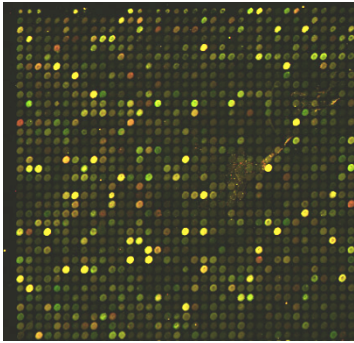

“High-Throughput BioTech”

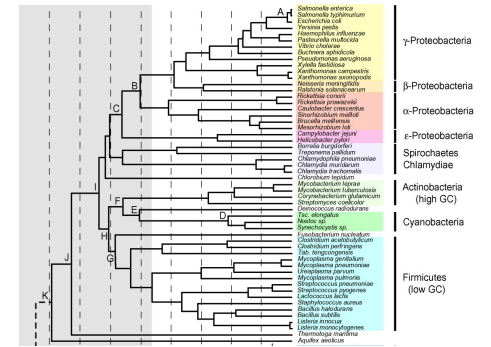

Sensors

- DNA sequencing
- Microarrays/Gene expression
- Mass Spectrometry/Proteomics
- Protein/protein & DNA/protein interaction

Controls

- Cloning
- Gene knock out/knock in
- DNA editing
- RNAi

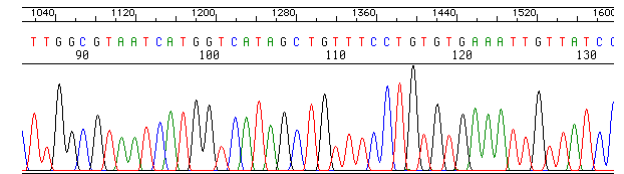

A

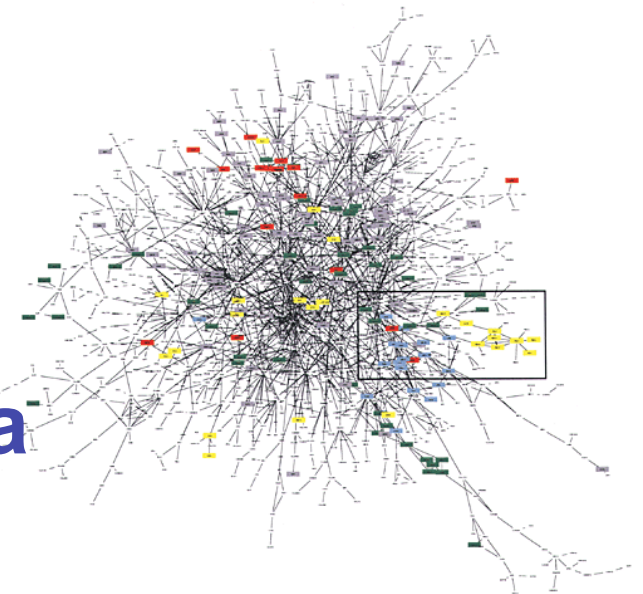

Floods of data

“Grand Challenge” problems

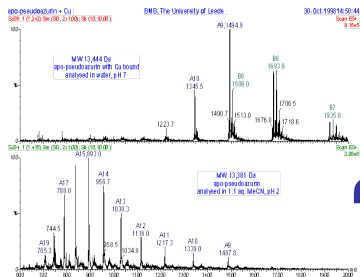

What's all the fuss?

The human genome is “finished”...
But that's only the beginning
Explosive growth in data is
revolutionizing biology & medicine

**“All pre-genomic lab
techniques are obsolete”**

(and computation and mathematics are
crucial to post-genomic analysis)

CS Points of Contact & Opportunities

Scientific visualization

- Gene expression patterns

Databases

- Integration of complex, disparate, overlapping data sources

- Distributed genome annotation in face of shifting underlying genomic coordinates, individual variation, ...

AI/NLP/Text Mining

- Information extraction from text with inconsistent nomenclature, indirect interactions, incomplete/inaccurate models, ...

Machine learning

- System level synthesis of cell behavior from low-level heterogeneous data (DNA seq, gene expression, protein interaction, mass spec,...)

...

Algorithms

More Admin

Why Take This Course?

IT and Genomics are, and probably will remain, the 2 most explosively transformative technologies of your lifetimes

Even if you don't choose to work at that interface, having some knowledge of it will be valuable

Hopefully, you will learn useful alg, ML, stats techniques and ideas for how to apply them in novel domains

Course Focus & Goals

Mainly sequence analysis

Algorithms for alignment, search, & discovery

Specific sequences, general types (“genes”, etc.)

Single sequence and comparative analysis

Techniques: HMMs, EM, MLE, Gibbs, Viterbi...

Enough bio to motivate these problems

including very light intro to modern biotech supporting them

Math/stats/cs underpinnings thereof

Applied to real data

A *VERY* Quick Intro To Molecular Biology

The Genome

The hereditary info present in every cell

DNA molecule -- a long sequence of
nucleotides (A, C, T, G)

Human genome -- about 3×10^9 nucleotides

The genome project -- extract & interpret
genomic information, apply to genetics of
disease, better understand evolution, ...

The Double Helix

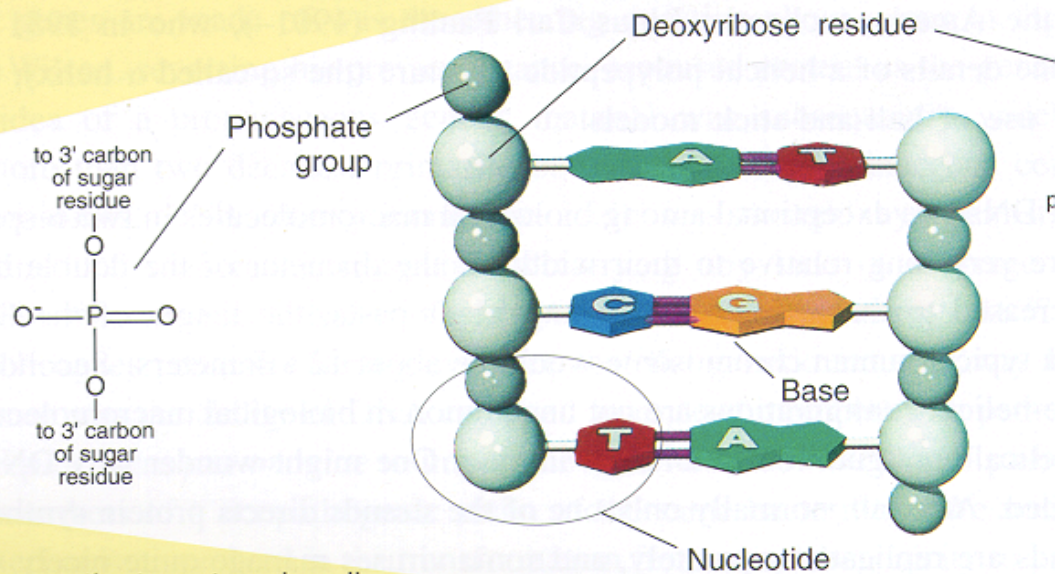
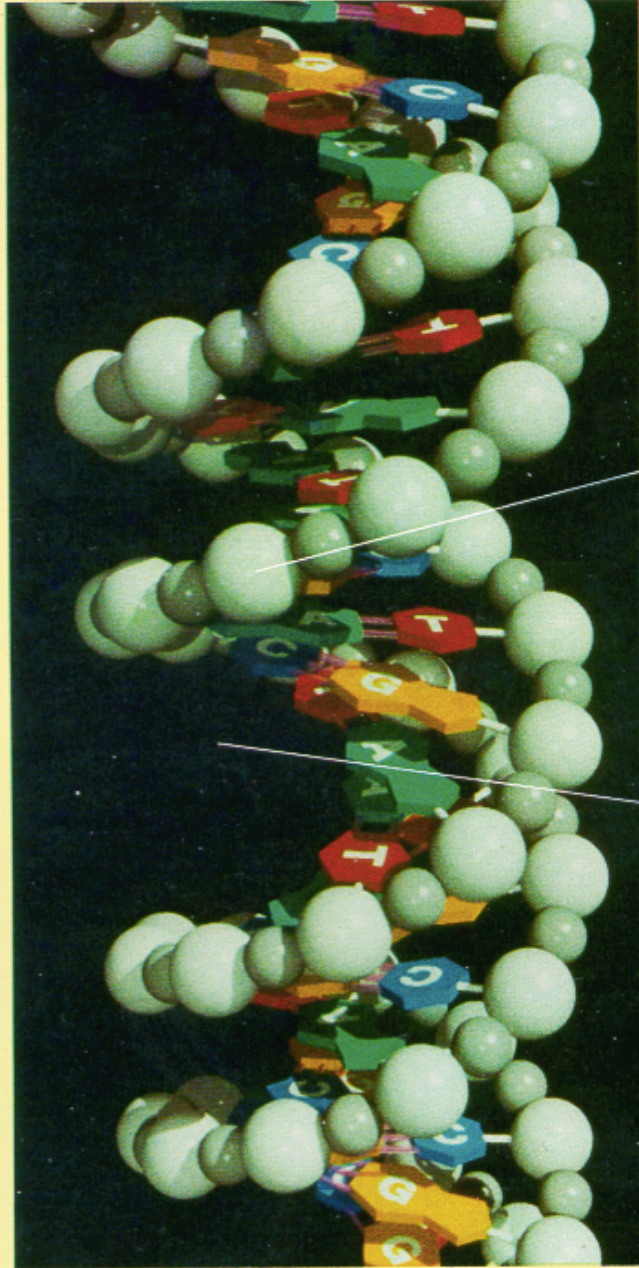

As shown, the two strands coil about each other in a fashion such that all the bases project inward toward the helix axis. The two strands are held together by hydrogen bonds (pink rods) linking each base projecting from one backbone to its so-called complementary base projecting from the other backbone. The base A always bonds to T (A and T are comple-

Shown in (b) is an uncoiled fragment of (a three complementary base pair chemist's viewpoint, each strand a polymer made up of four recalled deoxyribonucleotides

DNA

Discovered 1869

Role as carrier of genetic information – 1940's

4 “bases”:

adenine (A), cytosine (C), guanine (G), thymine (T)

The Double Helix - Watson & Crick (& Franklin) 1953

Complementarity

$A \longleftrightarrow T$ $C \longleftrightarrow G$

Visualization:

<http://www.rcsb.org/pdb/explore.do?structureId=123D>

Genetics - the study of heredity

A *gene* – classically, an abstract heritable attribute existing in variant forms (*alleles*)

ABO blood type – 1 gene, 3 alleles

Mendel

Each individual two copies of each gene

Each parent contributes one (randomly)

Independent assortment (approx, but useful)

Genotype vs phenotype

I.e., genes vs their outward manifestation

AA or AO genotype → “type A” phenotype

Cells

Chemicals inside a sac - a fatty layer called the *plasma membrane*

Prokaryotes (bacteria, archaea) - little recognizable substructure

Eukaryotes (all multicellular organisms, and many single celled ones, like yeast) - genetic material in nucleus, other organelles for other specialized functions

Chromosomes

1 pair of (complementary) DNA molecules
(+ protein wrapper)

Most prokaryotes: just 1 chromosome

Eukaryotes - ~~all~~^{most} cells have same number
of chromosomes, e.g. fruit flies 8, humans
& bats 46, rhinoceros 84, ...

Mitosis/Meiosis

Most “higher” eukaryotes are *diploid* - have homologous pairs of chromosomes, one maternal, other paternal (exception: sex chromosomes)

Mitosis - cell division, duplicate each chromosome, 1 copy to each daughter cell

Meiosis - 2 divisions form 4 *haploid* gametes (egg/sperm)

Recombination/crossover -- exchange maternal/paternal segments

Proteins

Chain of amino acids, of 20 kinds

Proteins: the major functional elements in cells

- Structural/mechanical

- Enzymes (catalyze chemical reactions)

- Receptors (for hormones, other signaling molecules, odorants,...)

- Transcription factors

- ...

3-D Structure is crucial: the protein folding problem

The “Central Dogma”

Genes encode proteins

DNA transcribed into messenger RNA

mRNA translated into proteins

Triplet code (codons)

Transcription: DNA → RNA

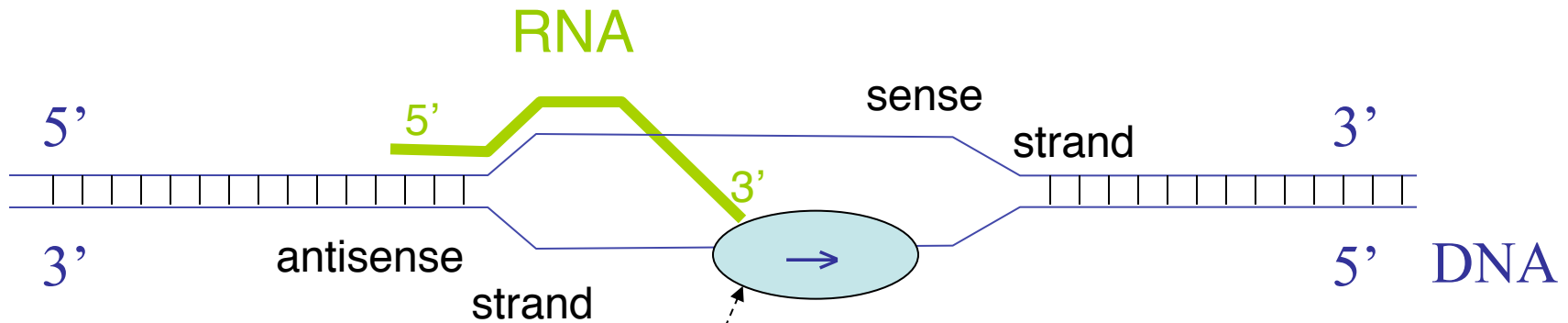

RNA polymerase

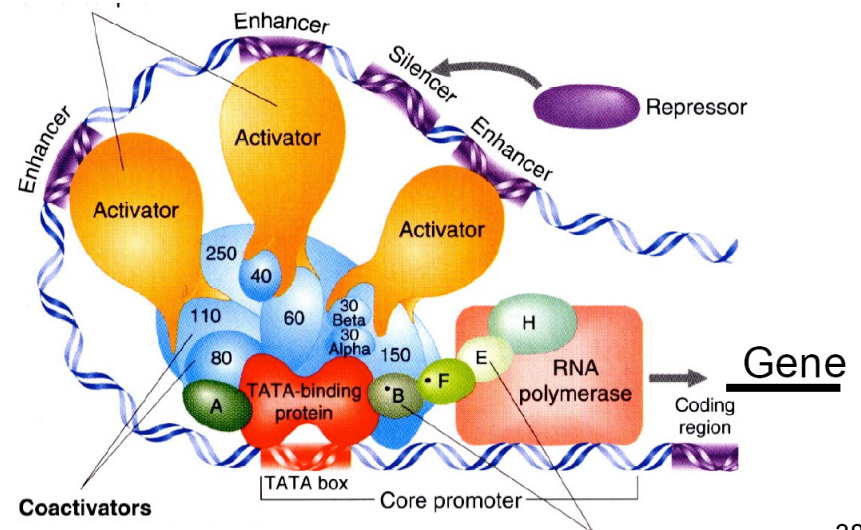

Codons & The Genetic Code

		Second Base					
		U	C	A	G		
First Base	U	Phe	Ser	Tyr	Cys	Third Base	U
		Phe	Ser	Tyr	Cys		C
		Leu	Ser	Stop	Stop		A
		Leu	Ser	Stop	Trp		G
	C	Leu	Pro	His	Arg		U
		Leu	Pro	His	Arg		C
		Leu	Pro	Gln	Arg		A
		Leu	Pro	Gln	Arg		G
	A	Ile	Thr	Asn	Ser		U
		Ile	Thr	Asn	Ser		C
		Ile	Thr	Lys	Arg		A
		Met/Start	Thr	Lys	Arg		G
	G	Val	Ala	Asp	Gly		U
		Val	Ala	Asp	Gly		C
		Val	Ala	Glu	Gly		A
		Val	Ala	Glu	Gly		G

Ala : Alanine
 Arg : Arginine
 Asn : Asparagine
 Asp : Aspartic acid
 Cys : Cysteine
 Gln : Glutamine
 Glu : Glutamic acid
 Gly : Glycine
 His : Histidine
 Ile : Isoleucine
 Leu : Leucine
 Lys : Lysine
 Met : Methionine
 Phe : Phenylalanine
 Pro : Proline
 Ser : Serine
 Thr : Threonine
 Trp : Tryptophane
 Tyr : Tyrosine
 Val : Valine

Translation: mRNA → Protein

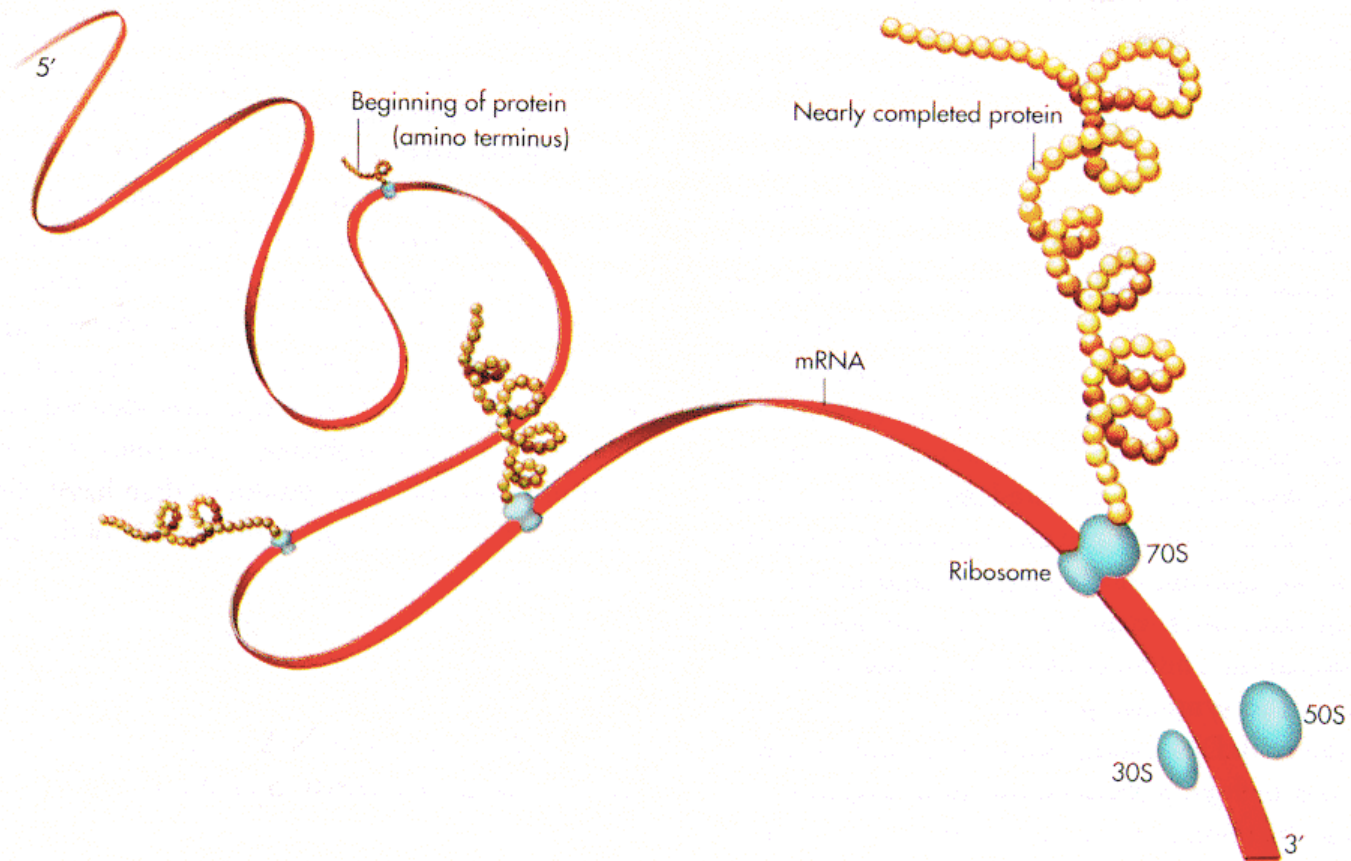

Ribosomes

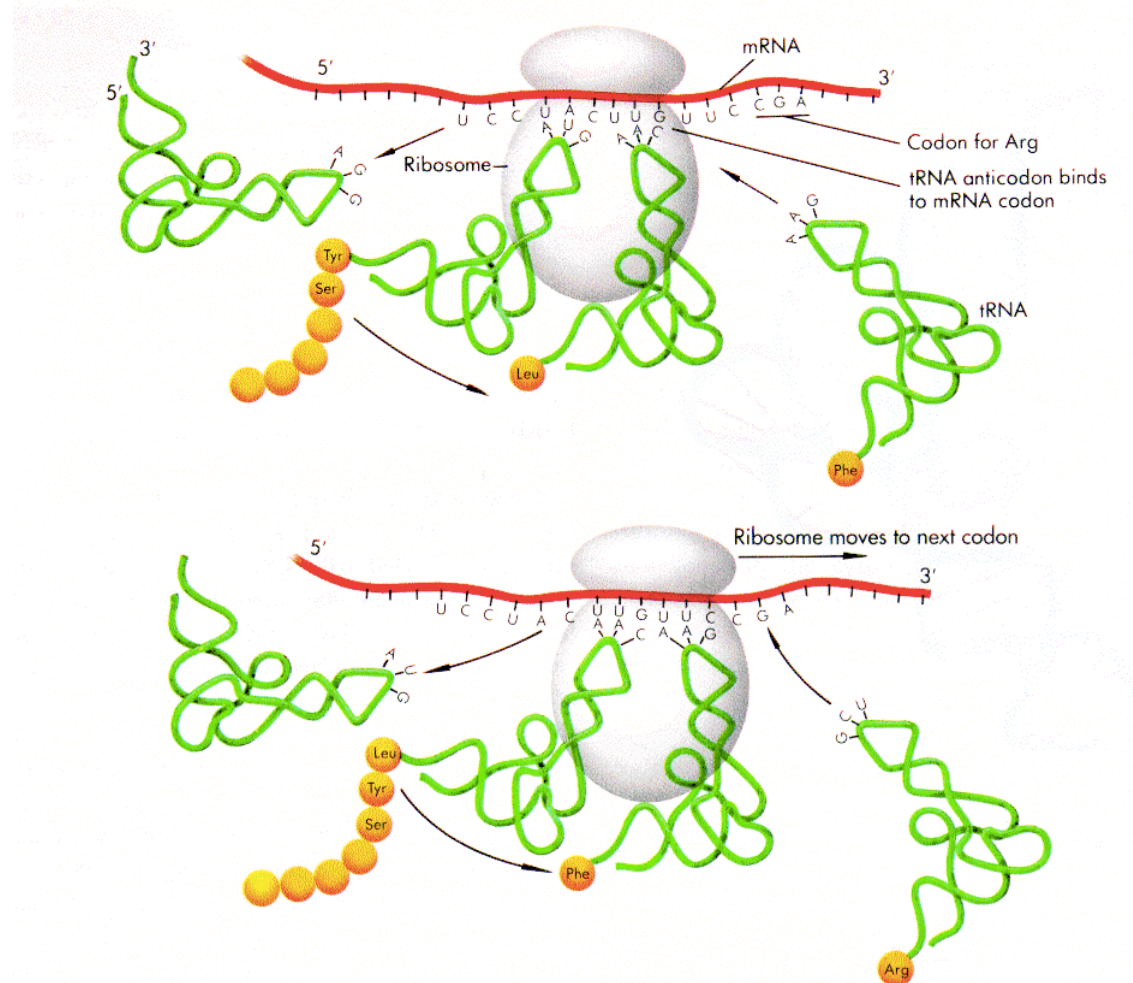

Gene Structure

mRNA built 5' to 3'

Promoter region and transcription factor binding sites (usually) precede 5' end

Transcribed region includes 5' and 3' untranslated regions

In eukaryotes, most genes also include *introns*, spliced out before export from nucleus, hence before translation

Genome Sizes

	Base Pairs	Genes
Mycoplasma genitalium	580,073	483
Pandora Virus	2,900,000	2,500
E. coli	4,639,221	4,290
Saccharomyces cerevisiae	12,495,682	5,726
Caenorhabditis elegans	95,500,000	19,820
Arabidopsis thaliana	115,409,949	25,498
Drosophila melanogaster	122,653,977	13,472
Humans	3.3×10^9	~20,000
Amoeba dubia	~ 200 x human	

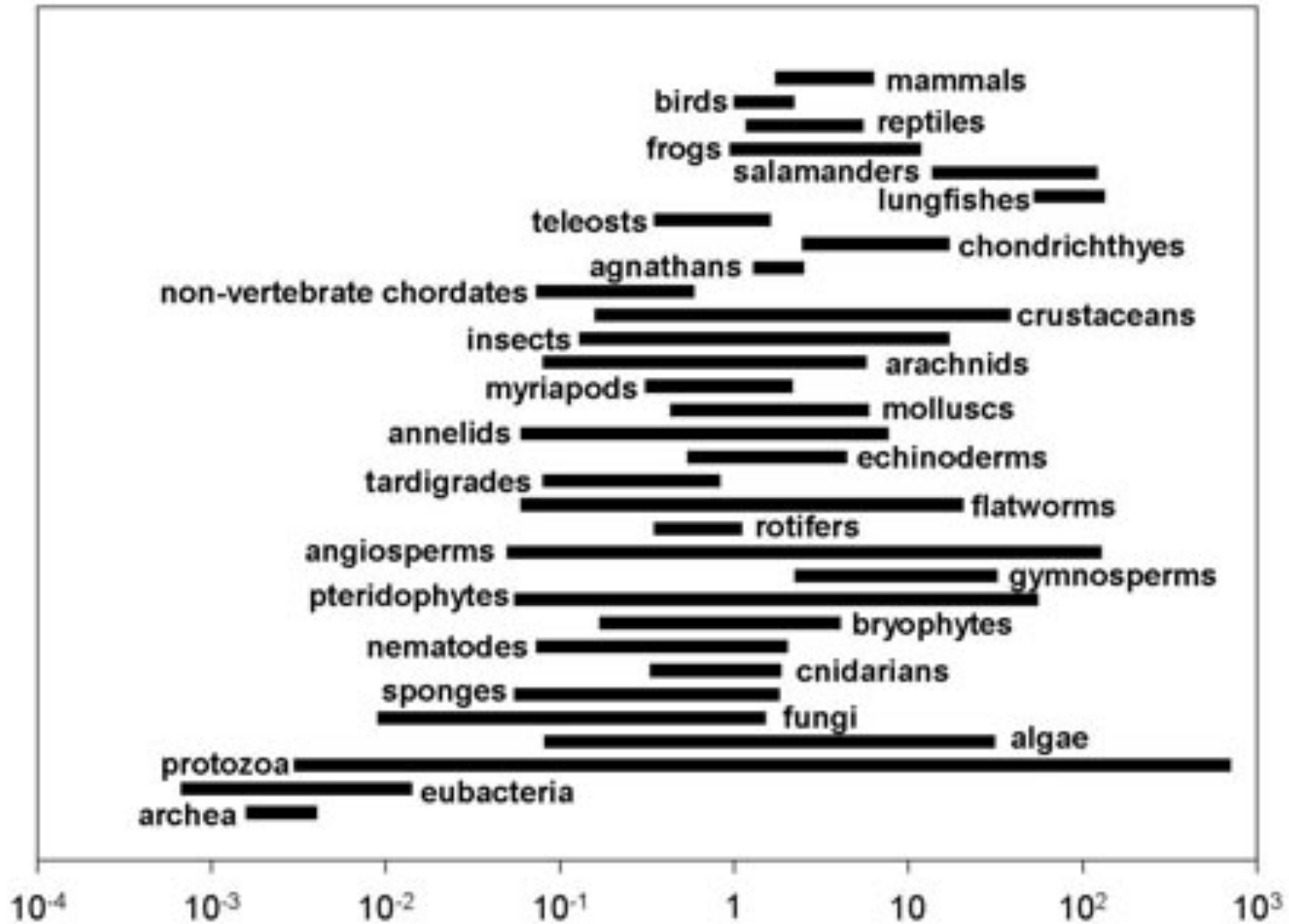

DNA content (picograms)

<http://www.genomesize.com/statistics.php>

Genome Surprises

Humans have $< 1/3$ as many genes as expected

But unexpectedly many proteins, due to *alternative processing*

Protein-wise, all mammals are just about the same

But more individual variation than expected

And many more *non-coding RNAs* -- more than protein-coding genes, by some estimates

Many other non-coding regions are highly conserved, e.g., across all vertebrates

Subset of DNA being transcribed is $\gg 2\%$ coding

Complex, subtle “epigenetic” information

... and much more ...

Read one of the many intro surveys or books for much more info.

Homework #1 (partial)

Read Hunter's "bio for cs" primer;

Find & read another

Post a few sentences saying

What you read (give me a link or citation)

Critique it for your meeting your needs

Who would it have been good for, if not you

See class web ~~(coming soon)~~ for more details

Bio Concept Summary

cells

DNA

base pairing

genome

replication, transcription, translation