

Edge Operators

a kind of filtering that leads to
useful features

Lines and Arcs Segmentation

In some image sets, lines, curves, and circular arcs are more useful than regions or helpful in addition to regions.

Lines and arcs are often used in

- object recognition
- stereo matching
- document analysis

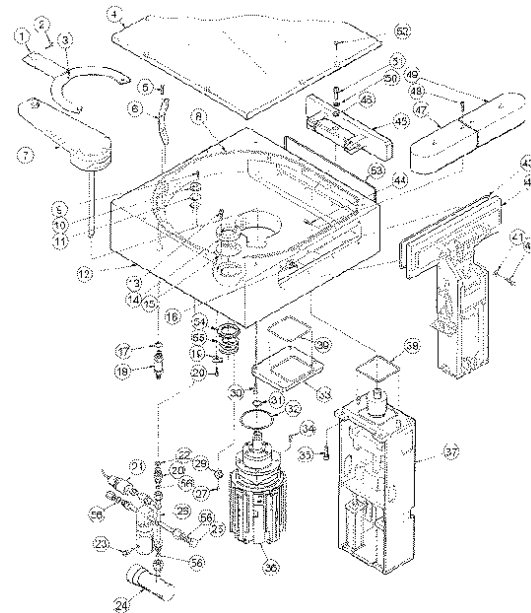

Edge Detection

Basic idea: look for a neighborhood with strong signs of change.

Problems:

- neighborhood size
- how to detect change

81	82	26	24
82	33	25	25
81	82	26	24

Differential Operators

Differential operators

- attempt to approximate the gradient at a pixel via masks
- threshold the gradient to select the edge pixels

Example: Sobel Operator

$$S_x = \begin{bmatrix} -1 & 0 & 1 \\ -2 & 0 & 2 \\ -1 & 0 & 1 \end{bmatrix}$$

$$S_y = \begin{bmatrix} 1 & 2 & 1 \\ 0 & 0 & 0 \\ -1 & -2 & -1 \end{bmatrix}$$

On a pixel of the image I

- let g_x be the response to S_x
- let g_y be the response to S_y

Then the gradient is
 $\nabla I = [g_x \ g_y]^T$

And $g = (g_x^2 + g_y^2)^{1/2}$ is the gradient magnitude.

$\theta = \text{atan2}(g_y, g_x)$ is the gradient direction.

Sobel Operator on the Blocks Image

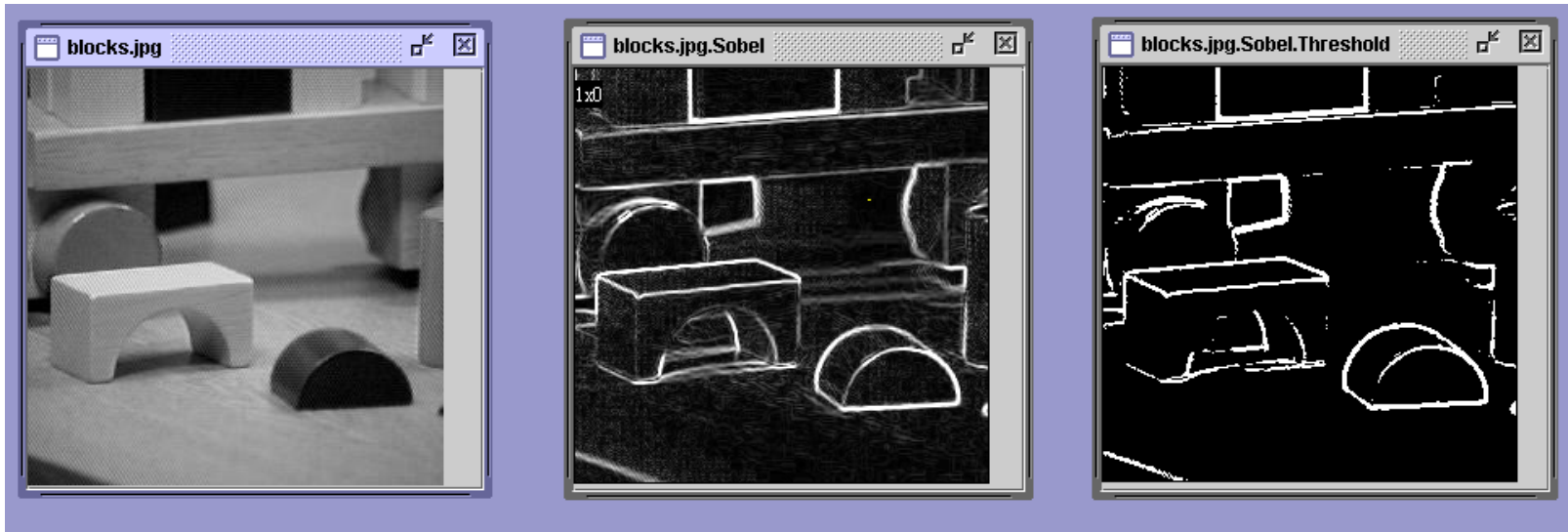

original image

gradient
magnitude

thresholded
gradient
magnitude

Common Masks for Computing Gradient

- Sobel:

$$\begin{bmatrix} -1 & 0 & 1 \\ -2 & 0 & 2 \\ -1 & 0 & 1 \end{bmatrix}$$

$$\begin{bmatrix} 1 & 2 & 1 \\ 0 & 0 & 0 \\ -1 & -2 & -1 \end{bmatrix}$$

- Prewitt:

$$\begin{bmatrix} -1 & 0 & 1 \\ -1 & 0 & 1 \\ -1 & 0 & 1 \end{bmatrix}$$

$$\begin{bmatrix} 1 & 1 & 1 \\ 0 & 0 & 0 \\ -1 & -1 & -1 \end{bmatrix}$$

- Roberts

$$\begin{bmatrix} 0 & 1 \\ -1 & 0 \end{bmatrix}$$

$$\begin{bmatrix} 1 & 0 \\ 0 & -1 \end{bmatrix}$$

Sx

Sy

Zero Crossing Operators

Motivation: The zero crossings of the second derivative of the image function are more precise than the peaks of the first derivative.

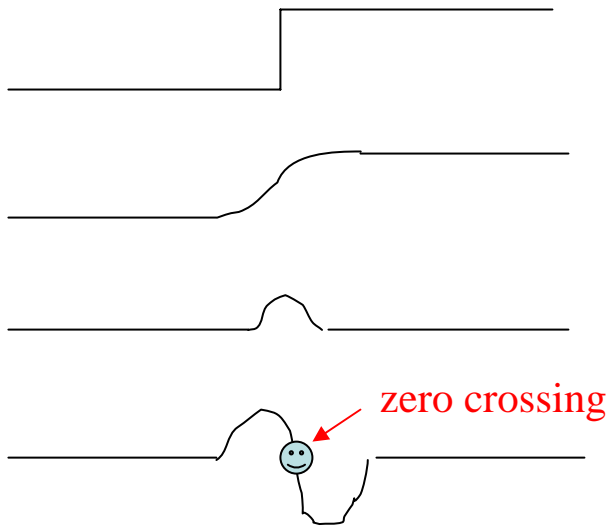

step edge

smoothed

1st derivative

2nd derivative

How do we estimate the Second Derivative?

- Laplacian Filter: $\nabla^2 f = \partial^2 f / \partial x^2 + \partial^2 f / \partial y^2$

0	1	0
1	-4	1
0	1	0

- Standard mask implementation
- Derivation: In 1D, the first derivative can be computed with mask [-1 0 1]
- The 1D second derivative is [1 -2 1]
- The Laplacian mask estimates the 2D second derivative.

Properties of Derivative Masks

- Coordinates of derivative masks have opposite signs in order to obtain a high response in regions of high contrast.
- The sum of coordinates of derivative masks is zero, so that a zero response is obtained on constant regions.
- First derivative masks produce high absolute values at points of high contrast.
- Second derivative masks produce zero-crossings at points of high contrast.

Marr/Hildreth Operator

- First **smooth** the image via a Gaussian convolution.
- Apply a **Laplacian filter** (estimate 2nd derivative).
- Find **zero crossings** of the Laplacian of the Gaussian.

This can be done at multiple resolutions.

Haralick Operator

- Fit the gray-tone intensity surface to a piecewise **cubic polynomial approximation**.
- Use the approximation to **find zero crossings** of the second directional derivative in the direction that maximizes the first directional derivative.

The derivatives here are calculated from **direct mathematical expressions** wrt the cubic polynomial.

Canny Edge Detector

- Smooth the image with a Gaussian filter with spread σ .
- Compute gradient **magnitude and direction** at each pixel of the smoothed image.
- **Zero out** any pixel response \leq the two neighboring pixels on either side of it, along the direction of the gradient.
- **Track high-magnitude contours.**
- **Keep only pixels along these contours**, so weak little segments go away.

Canny on Kidney



Canny Characteristics

- The Canny operator gives single-pixel-wide images with good continuation between adjacent pixels
- It is the most widely used edge operator today; no one has done better since it came out in the late 80s. Many implementations are available.
- It is very sensitive to its parameters, which need to be adjusted for different application domains.