

Recurrent Neural Networks

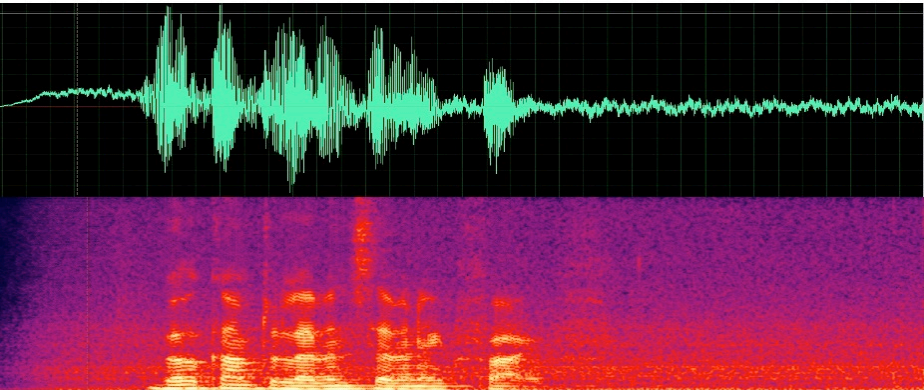

Sequence Data



检测语言 英语 中文 德语

↔ 中文 (简体) 英语 日语

Deep learning is a popular area in AI.

深度学习是AI的热门领域。

Shēndù xuéxí shì AI de rènmén lǐngyù.

38 / 5000

State-Space Model

- h_t : hidden state
- X_t : input
- Y_t : output
- $Y_t, h_t = f(h_{t-1}, X_t; \theta)$
- h_{-1} : initial state

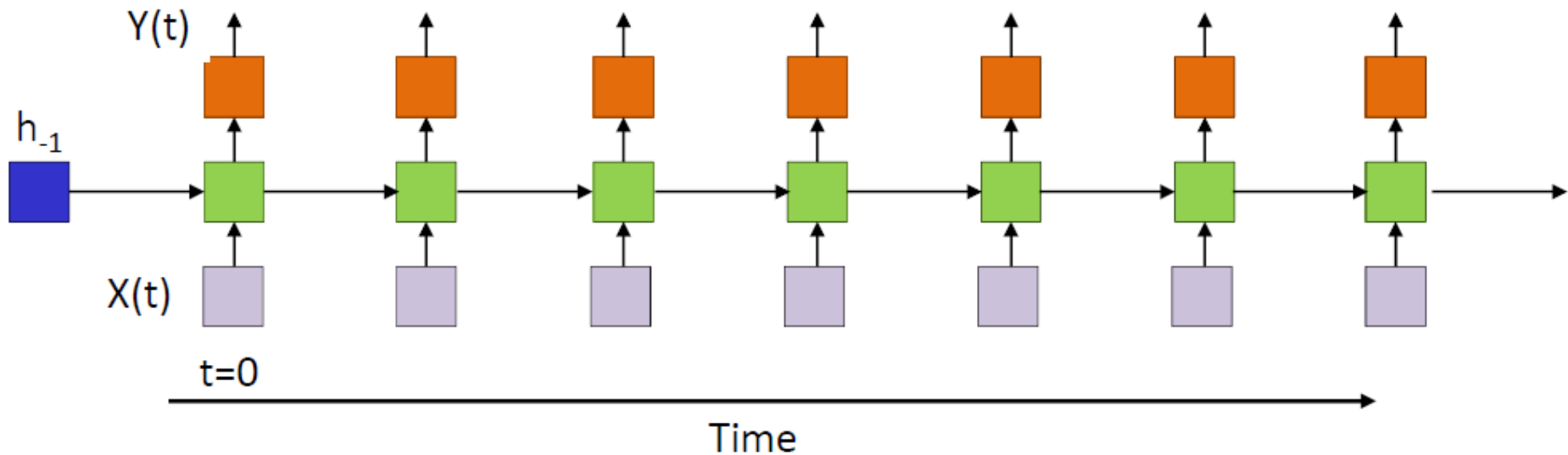

Recurrent Neural Network

- h_t : hidden state
- X_t : input
- Y_t : output
- $Y_t, h_t = f(h_{t-1}, X_t; \theta)$
- h_{-1} : initial state

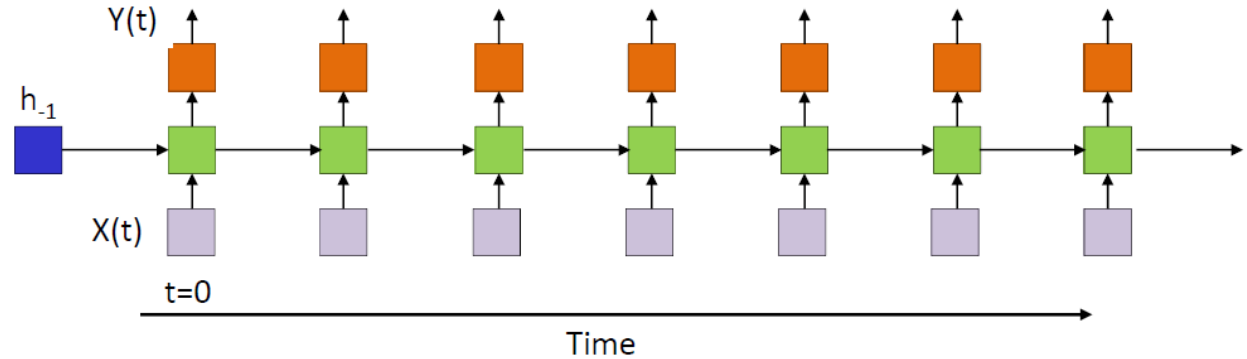

Fully-connect NN vs. RNN

- h_t : a vector summarizes all past inputs (a.k.a. “memory”)
- h_{-1} affects the entire dynamics (typically set to zero)
- X_t affects all the outputs and states after t
- Y_t depends on X_0, \dots, X_t

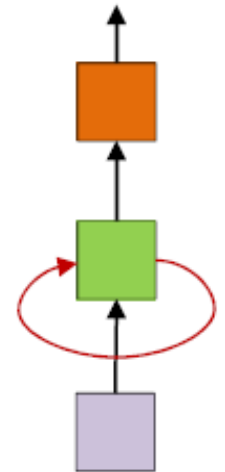

Recurrent Neural Network

- h_t : hidden state
- X_t : input
- Y_t : output
- $Y_t, h_t = f(h_{t-1}, X_t; \theta)$
- h_{-1} : initial state

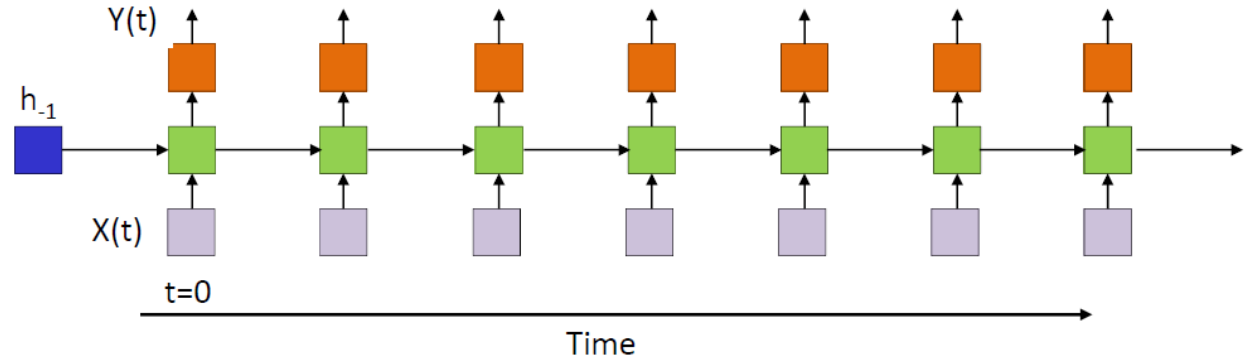

Fully-connect NN vs. RNN

- RNN can be viewed as repeated applying fully-connected NNs
- $h_t = \sigma_1(W^{(1)}X_t + W^{(11)}h_{t-1} + b^{(1)})$
- $Y_t = \sigma_2(W^{(2)}h_t + b^{(2)})$
- σ_1, σ_2 are activation functions (sigmoid, ReLU, tanh, etc)

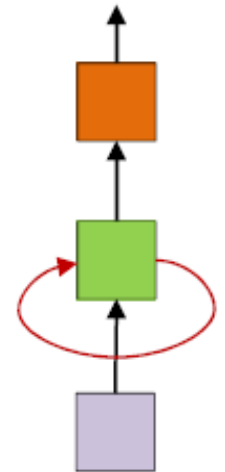

Recurrent Neural Network

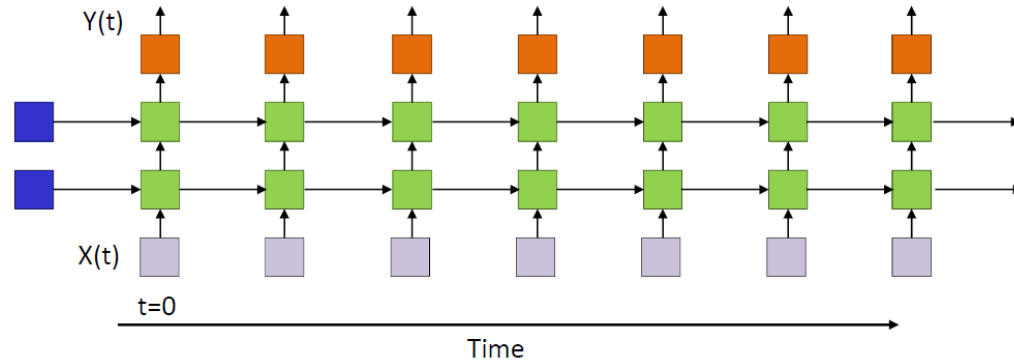

Stack K layers of fully-connected NN

- $h_t^{(k)}$: hidden state
- X_t : input
- Y_t : output
- $h_t^{(1)} = f_1^{(1)}(h_{t-1}^{(1)}, X_t; \theta)$
- $h_t^{(k)} = f_1^{(k)}(h_{t-1}^{(k)}, h_t^{(k-1)}; \theta)$
- $Y_t = f_2(h_t^{(K)}; \theta)$
- $h_{-1}^{(k)}$: initial states

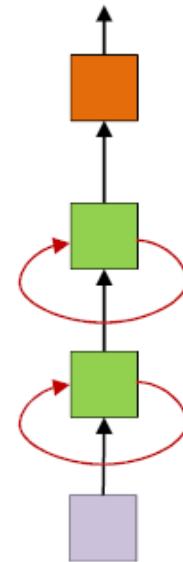

Training Recurrent Neural Network

- h_t : hidden state
- X_t : input
- Y_t : output
- $Y_t, h_t = f(h_{t-1}, X_t; \theta)$
- h_{-1} : initial state

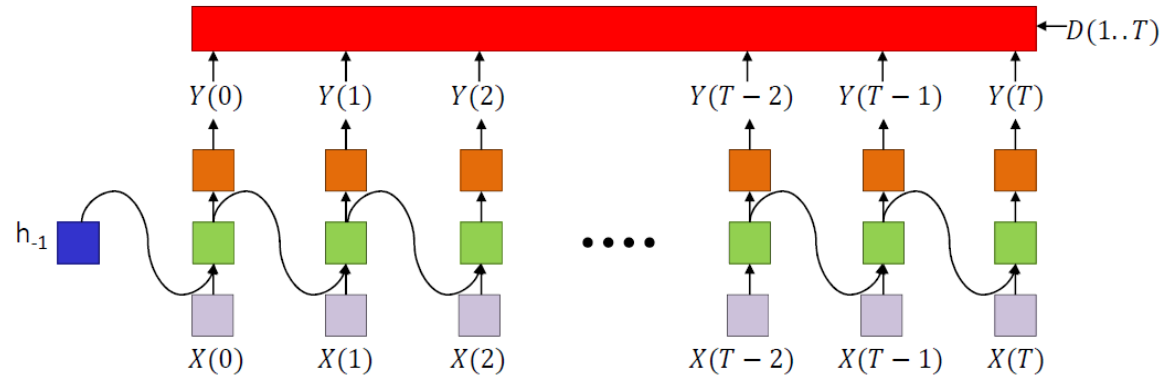

- Data: $\{(X_t, D_t)\}_{t=1}^T$ (RNN can handle more general data format)
- Loss $L(\theta) = \sum_{t=1}^T \ell(Y_t, D_t)$
- Goal: learn θ by gradient-based method
 - Back propagation

Extensions

What if Y_t depends on the entire inputs?

- Birectional RNN:

- AN RNN for forward dependencies: $t = 0, \dots, T$
- An RNN for backward dependencies: $t = T, \dots, 0$

- $Y_t = f_2(h_t^f, h_t^b; \theta)$

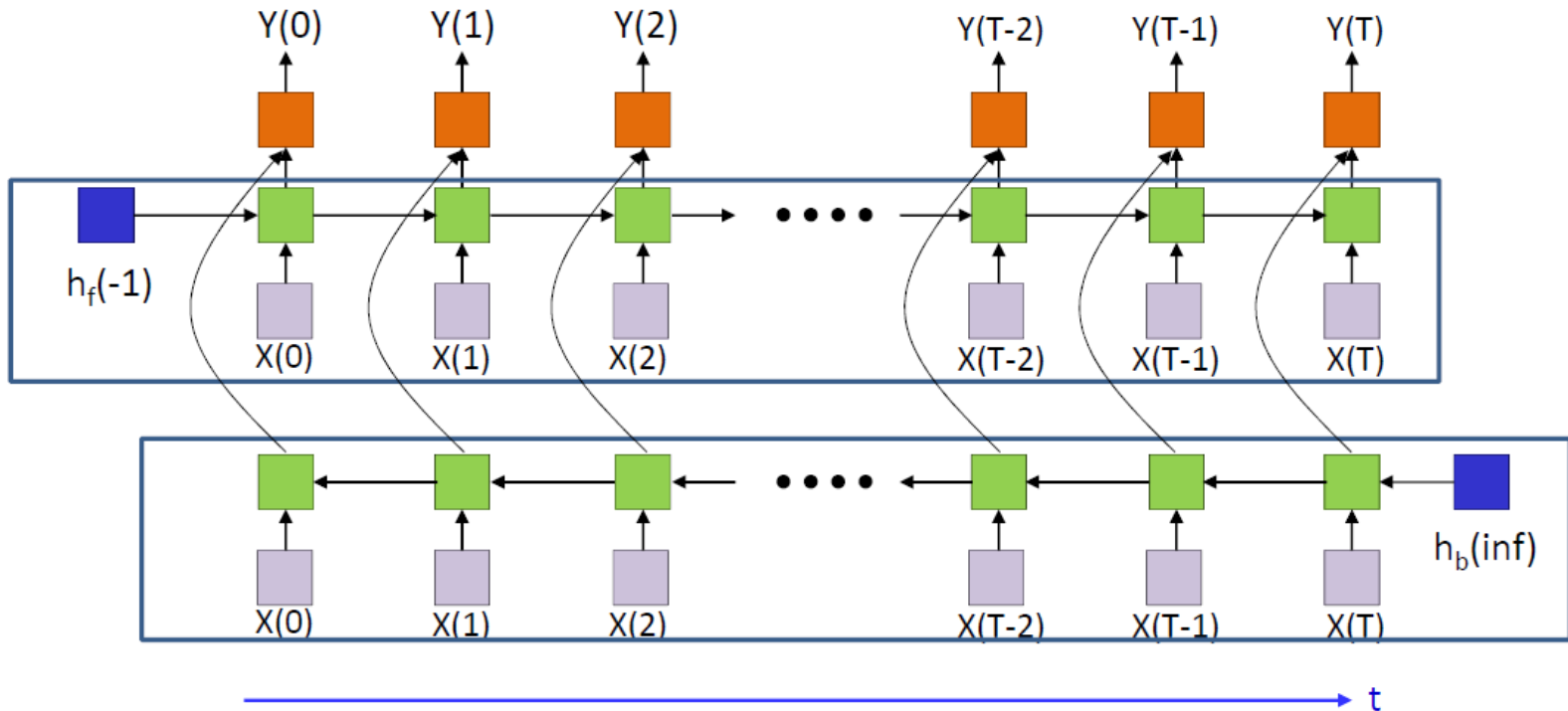

Extensions

RNN for sequence classification (sentiment analysis)

- $Y = \max_t Y_t$
- Cross-entropy loss

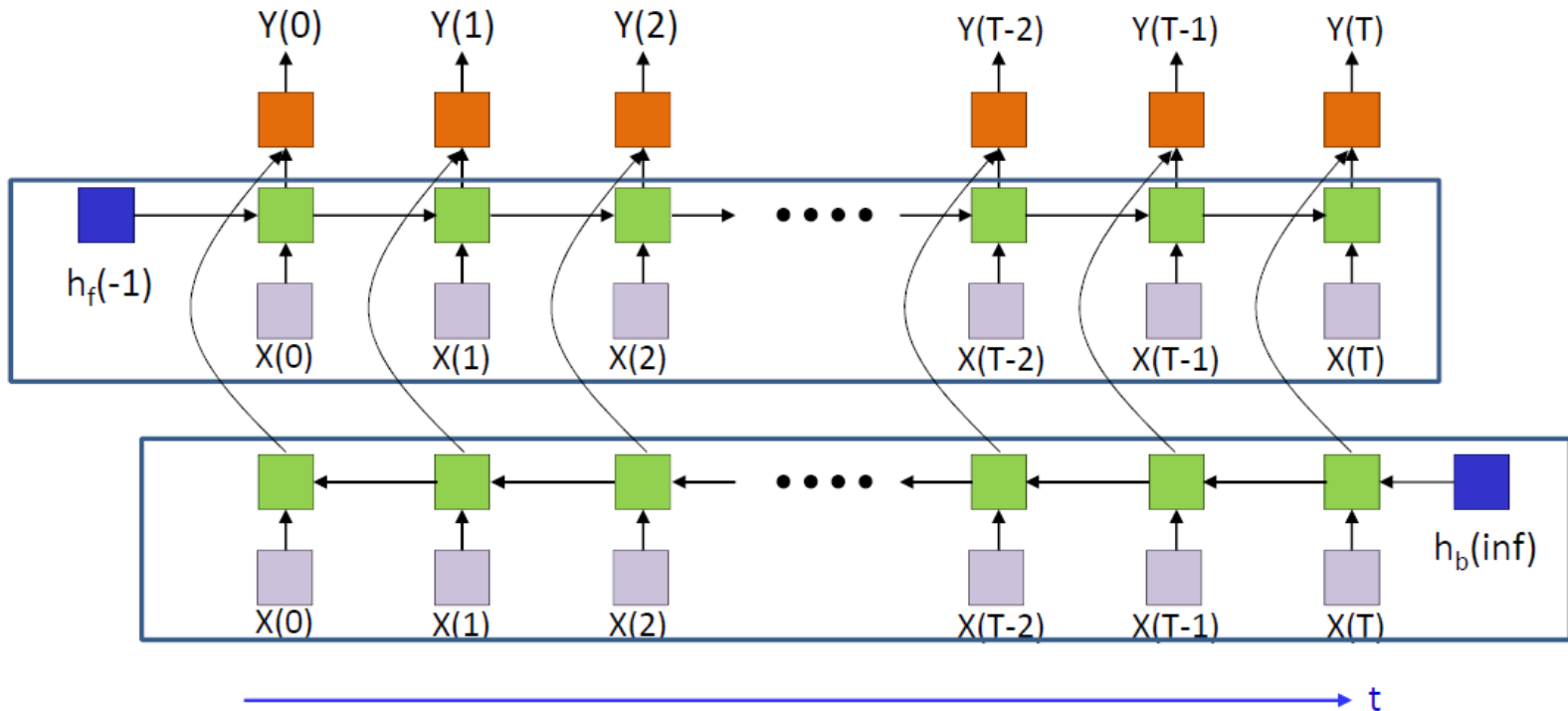

Practical issues of RNN

Linear RNN derivation

Practical issues of RNN: training

Gradient explosion and gradient vanishing

Techniques for avoiding gradient explosion

- Gradient clipping
- Identity initialization
- Truncated backprop through time
 - Only backprop for a few steps

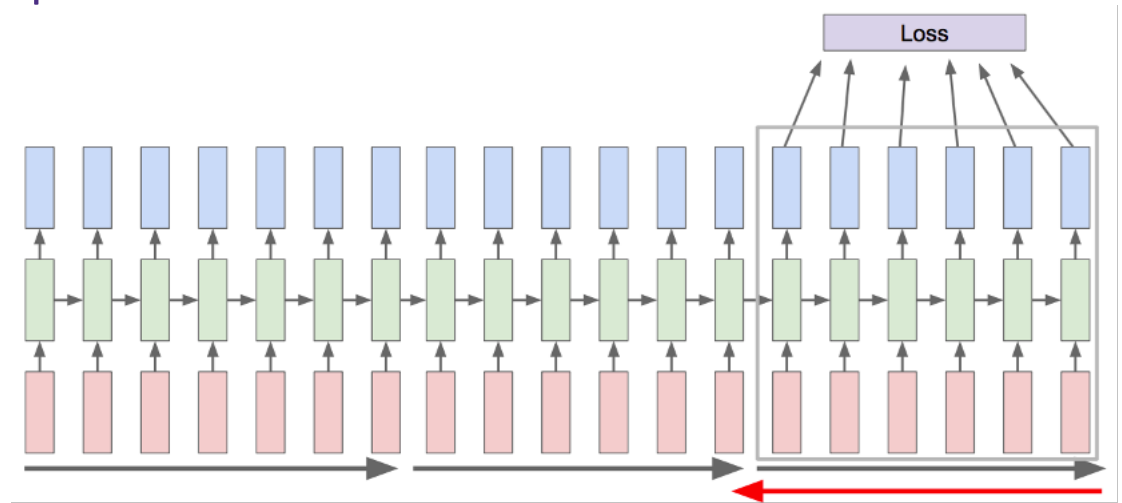

Preserve Long-Term Memory

- Difficult for RNN to preserve long-term memory
 - The hidden state h_t is constantly being written (short-term memory)
 - Use a separate cell to maintain long-term memory

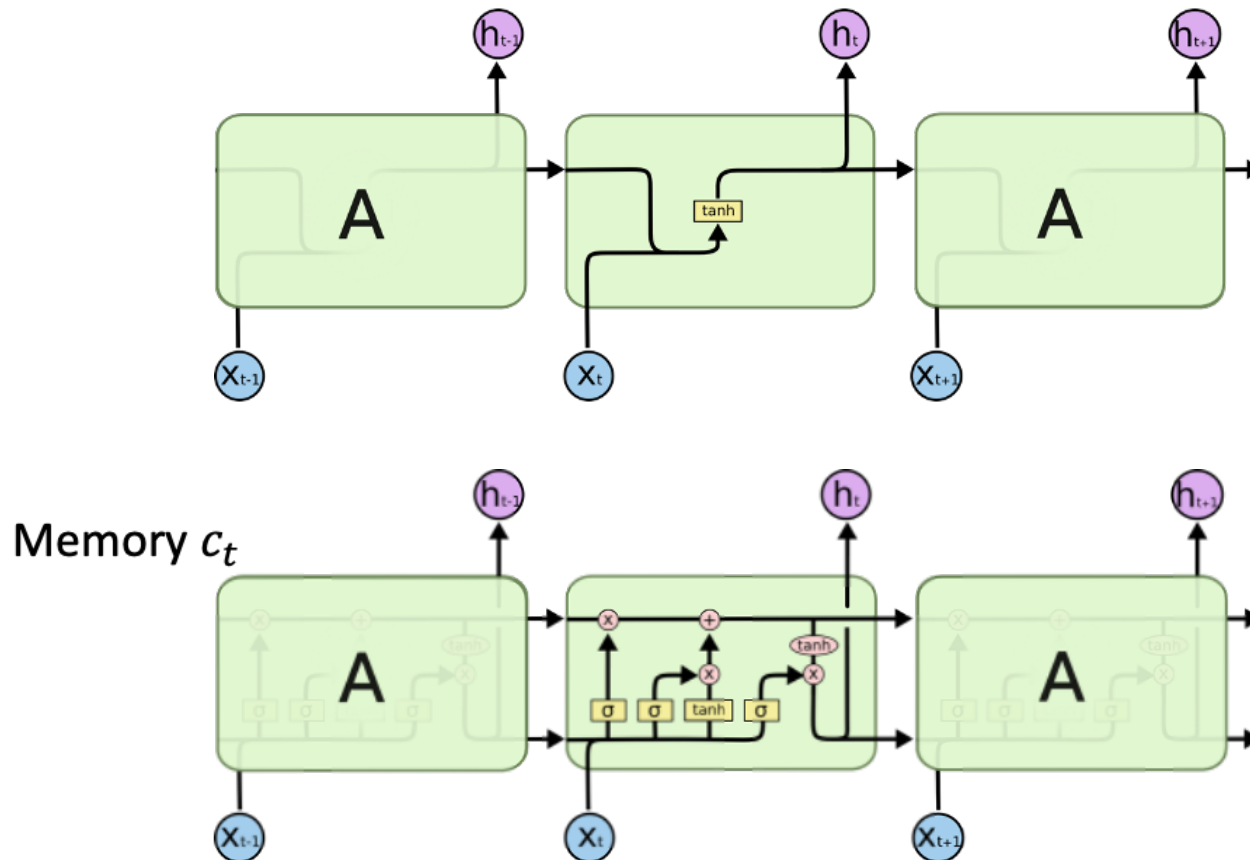

Long Short-Term Memory Network

LSTM (Hochreiter & Schmidhuber, '97)

- RNN architecture for learning long-term dependencies
- σ : layer with sigmoid activation

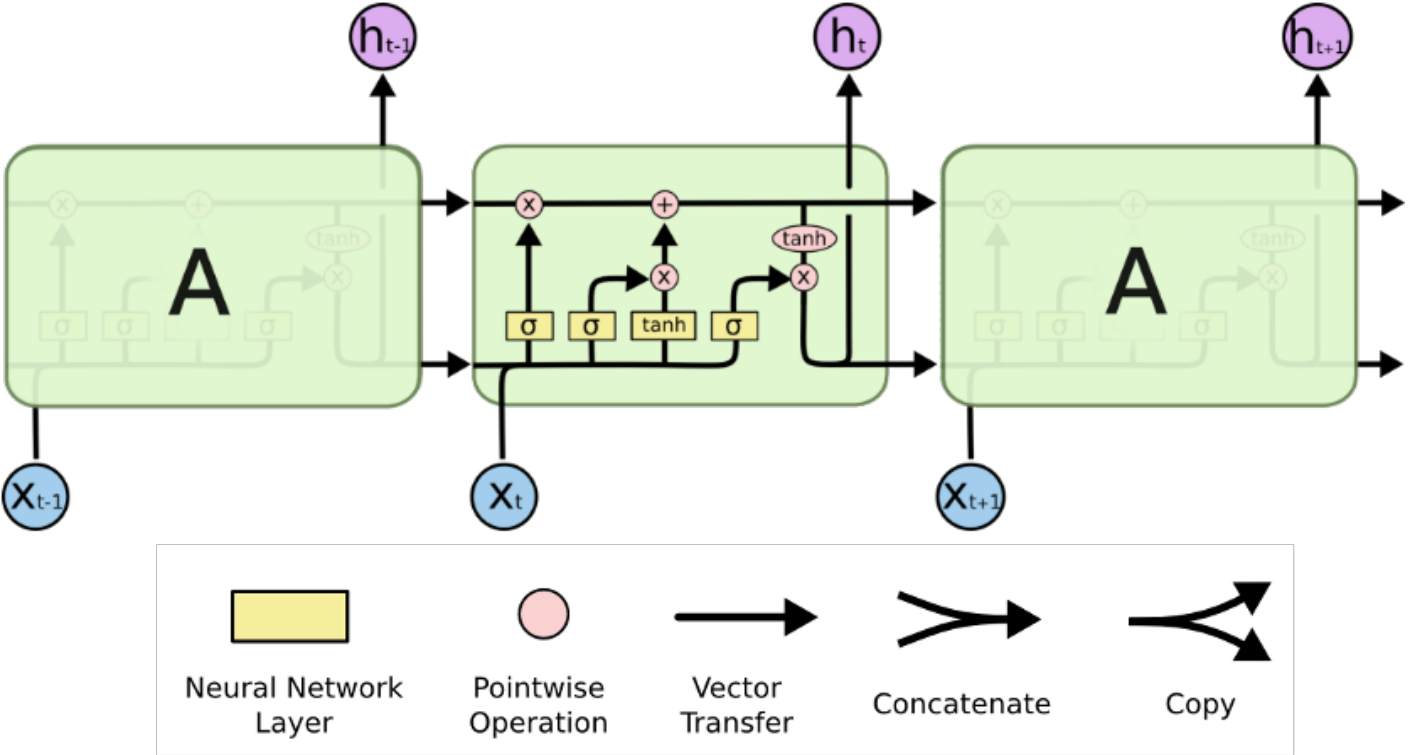

Long Short-Term Memory Network

LSTM (Hochreiter & Schmidhuber, '97)

- Core idea: maintain separate state h_t and cell c_t (memory)
- h_t : full update every step
- c_t : only *partially* update through gates
 - σ layer outputs importance ($[0,1]$) for each entry and only modify those entries of c_t

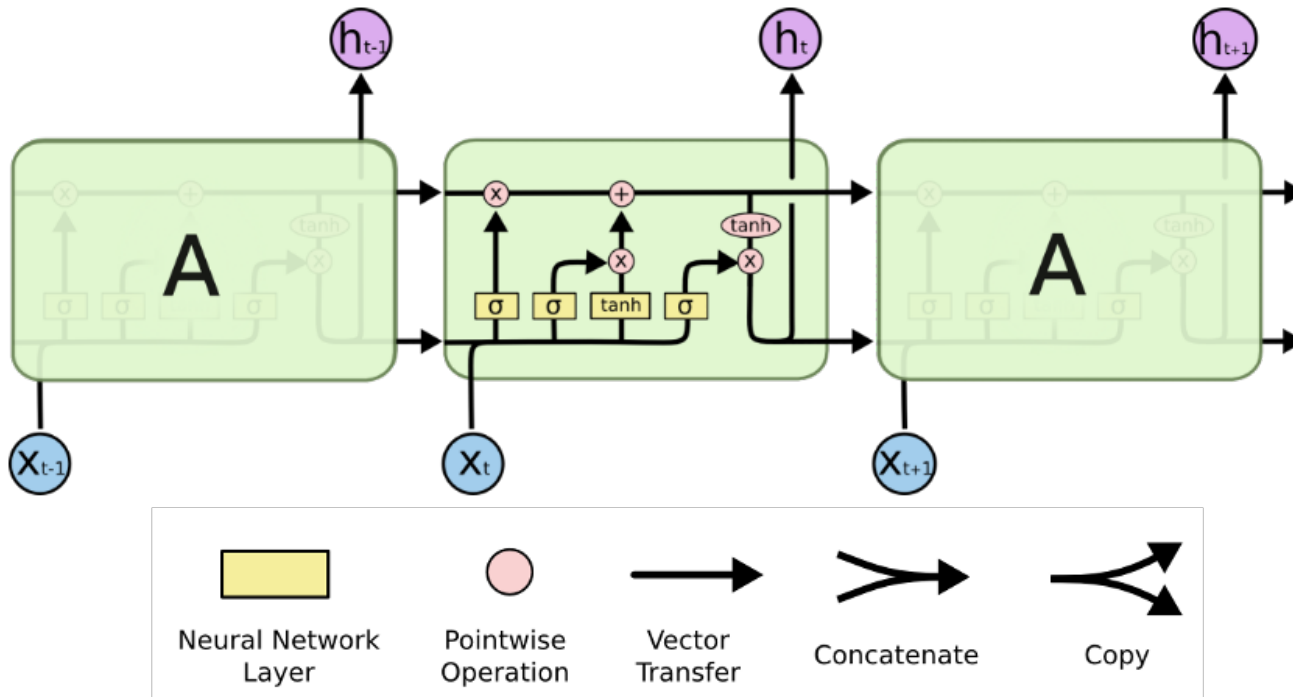

Long Short-Term Memory Network

Forget gate f_t

- f_t outputs whether we want to “forget” things in c_t
 - Compute $c_{t-1} \odot f_t$ (element-wise)
 - $f_t(i) \rightarrow 0$: want to forget $c_t(i)$
 - $f_t(i) \rightarrow 1$: we want to keep the information in $c_t(i)$

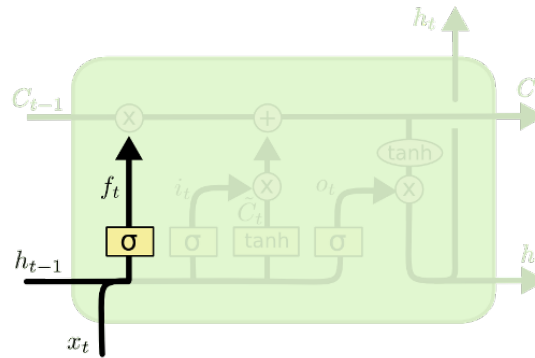
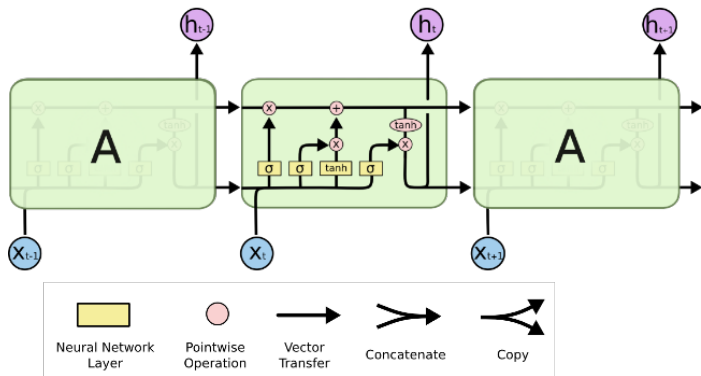

$$f_t = \sigma(W_f \cdot [h_{t-1}, x_t] + b_f)$$

Long Short-Term Memory Network

Input gate i_t

- i_t extracts useful information from X_t to update memory
 - \tilde{c}_t : information from X_t to update memory
 - i_t : which dimension in the memory should be updated by X_t
 - $i_t(j) \rightarrow 1$: we want to use the information in $\tilde{c}_t(j)$ to update memory
 - $i_t(j) \rightarrow 0$: $\tilde{c}_t(j)$ should not contribute to memory

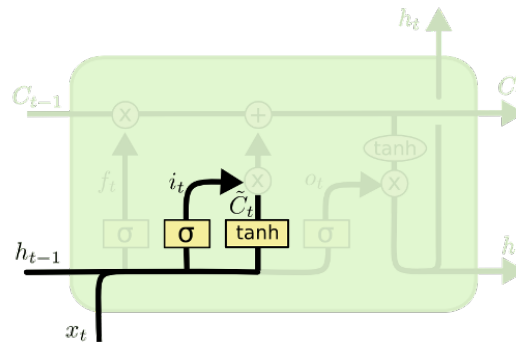
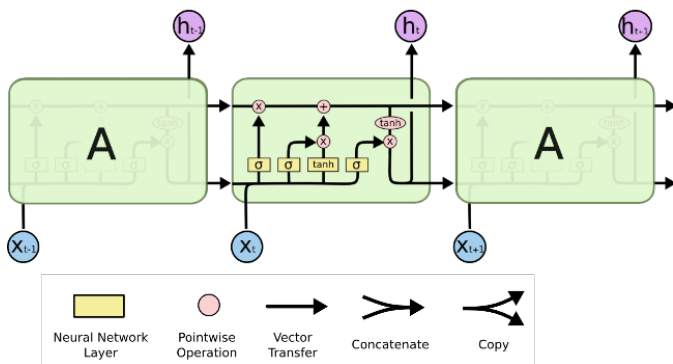

$$i_t = \sigma(W_i \cdot [h_{t-1}, x_t] + b_i)$$

$$\tilde{C}_t = \tanh(W_C \cdot [h_{t-1}, x_t] + b_C)$$

Long Short-Term Memory Network

Memory update

- $c_t = f_t \odot c_{t-1} + i_t \odot \tilde{c}_t$
- f_t forget gate; i_t input gate
- $f_t \odot c_{t-1}$: drop useless information in old memory
- $i_t \odot \tilde{c}_t$: add selected new information from current input

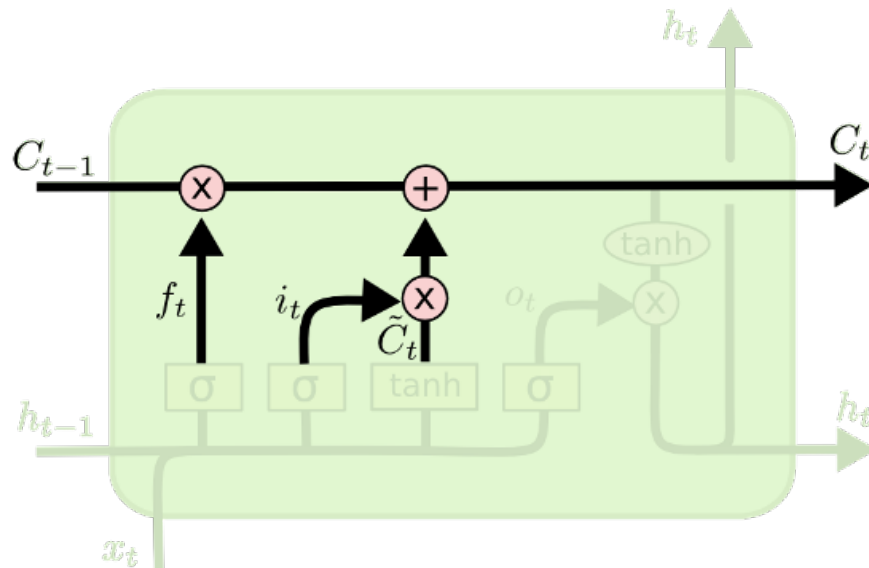

Long Short-Term Memory Network

Output gate o_t

- Next hidden state $h_t = o_t \odot \tanh(c_t)$
 - $\tanh(c_t)$: non-linear transformation over all past information
 - o_t : choose important dimensions for the next state
 - $o_t(j) \rightarrow 1$: $\tanh(c_t(j))$ is important for the next state
 - $o_t(j) \rightarrow 0$: $\tanh(c_t(j))$ is not important

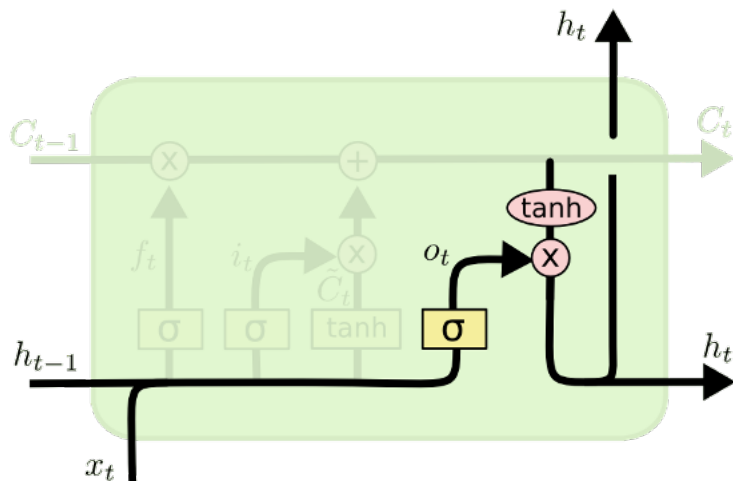

$$o_t = \sigma (W_o [h_{t-1}, x_t] + b_o)$$

$$h_t = o_t * \tanh (C_t)$$

Long Short-Term Memory Network

- $h_t = o_t \odot \tanh(c_t)$
- $c_t = f_t \odot c_{t-1} + i_t \odot \tilde{c}_t$
- $Y_t = g(h_t)$

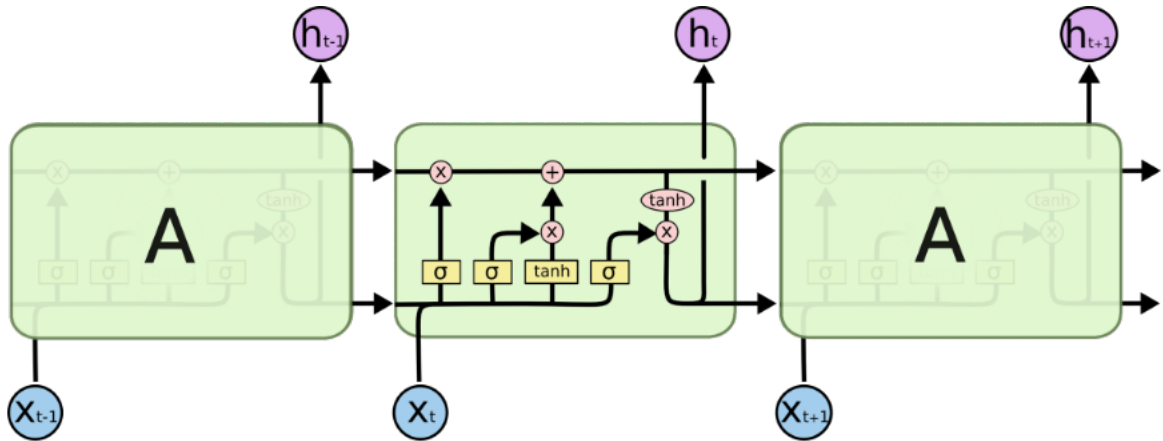

Remarks:

1. No more matrix multiplications for c_t
2. LSTM does not have guarantees for gradient explosion/vanishing
3. LSTM is the dominant architecture for sequence modeling from '13 - '16.
4. Why tanh

LSTM Variant

Peephole Connections (Gers & Schmidhuber '00)

- Allow gates to take in c_t information

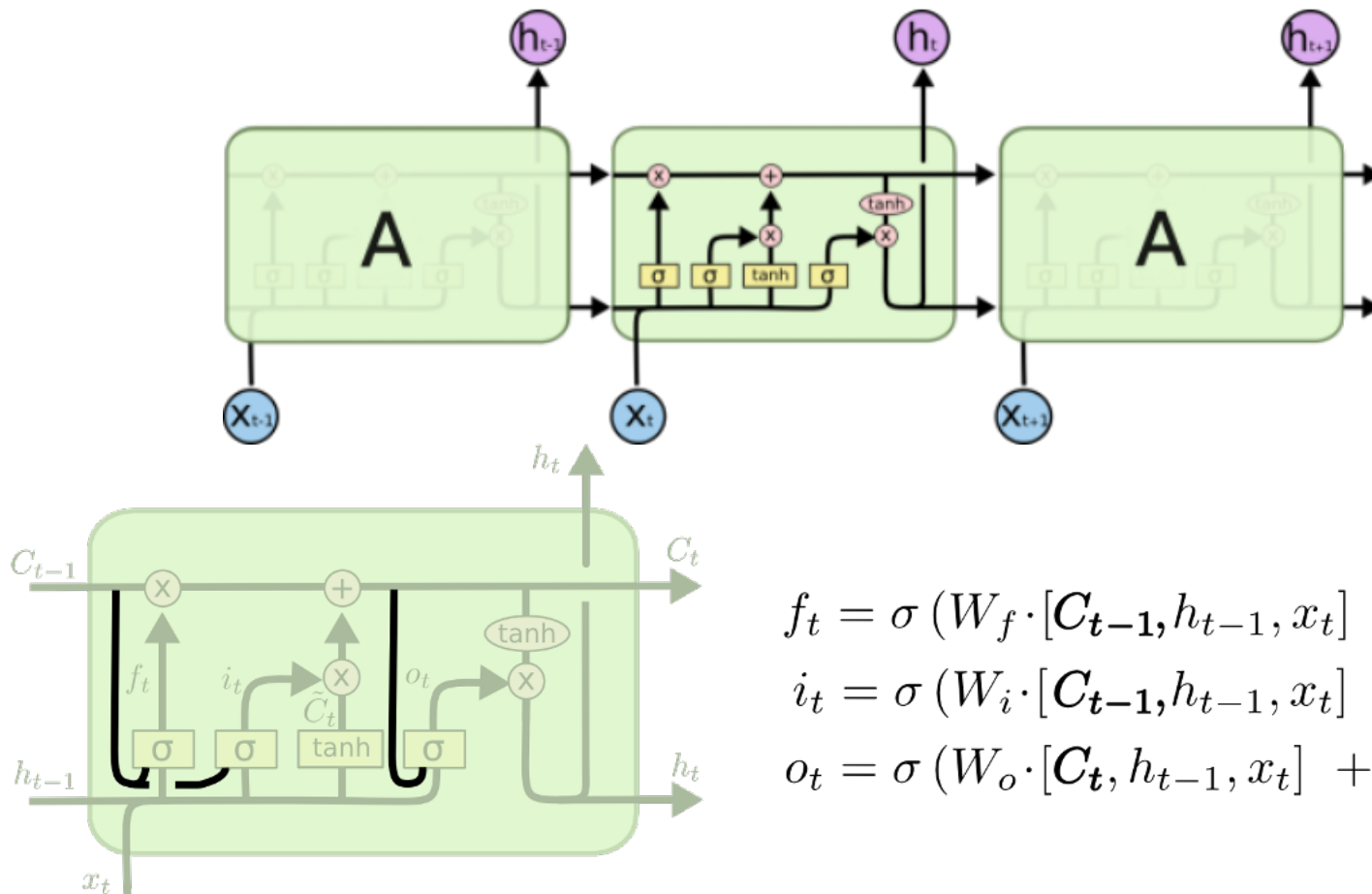

$$f_t = \sigma(W_f \cdot [C_{t-1}, h_{t-1}, x_t] + b_f)$$

$$i_t = \sigma(W_i \cdot [C_{t-1}, h_{t-1}, x_t] + b_i)$$

$$o_t = \sigma(W_o \cdot [C_t, h_{t-1}, x_t] + b_o)$$

LSTM Variant

Simplified LSTM

- Assume $i_t = 1 - f_t$
- Only two gates are needed: fewer parameters

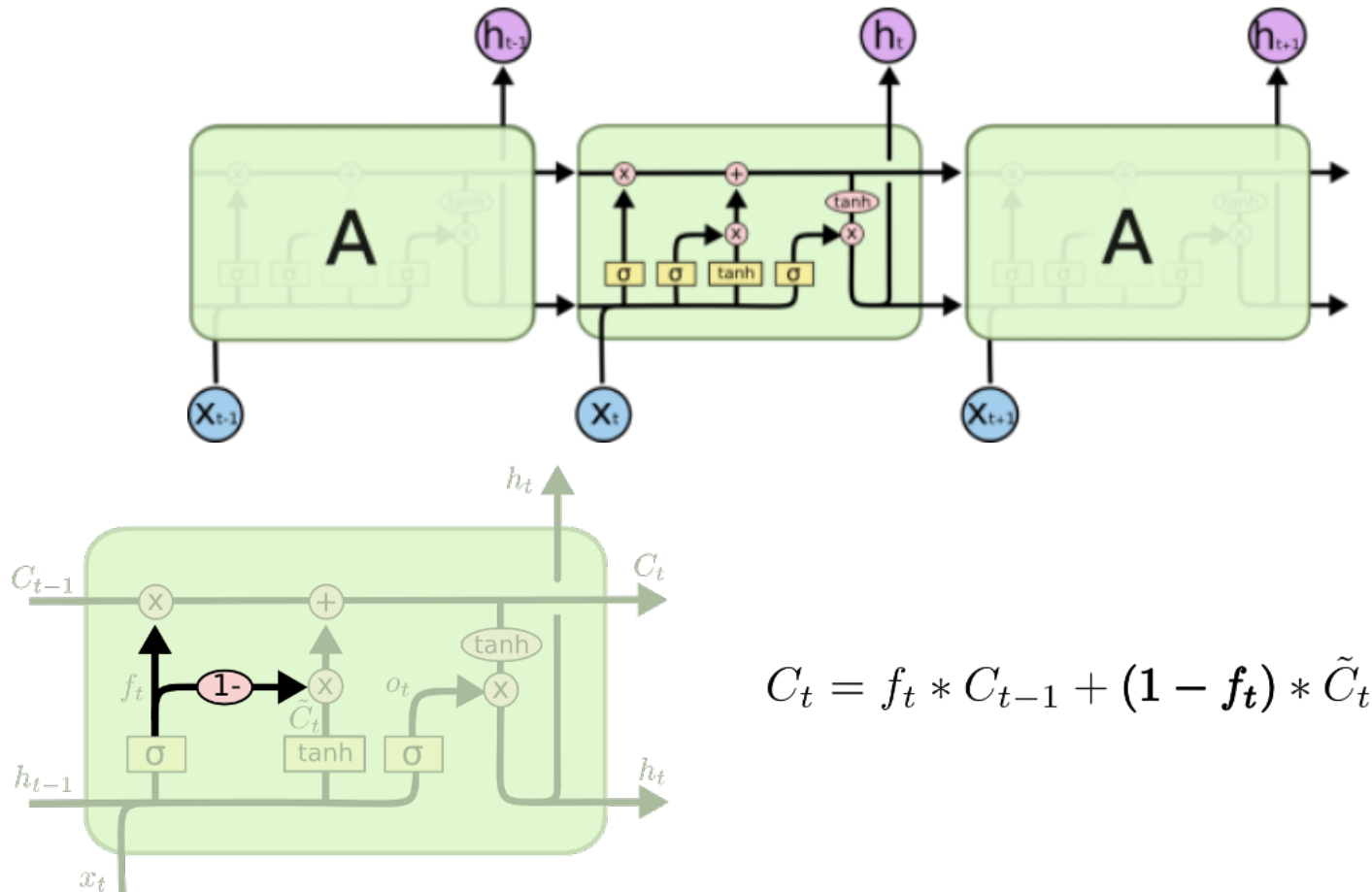

$$C_t = f_t * C_{t-1} + (1 - f_t) * \tilde{C}_t$$

LSTM Variant

Gated Recurrent Unit (GRU, Cho et al. '14)

- Merge h_t and c_t : much fewer parameters

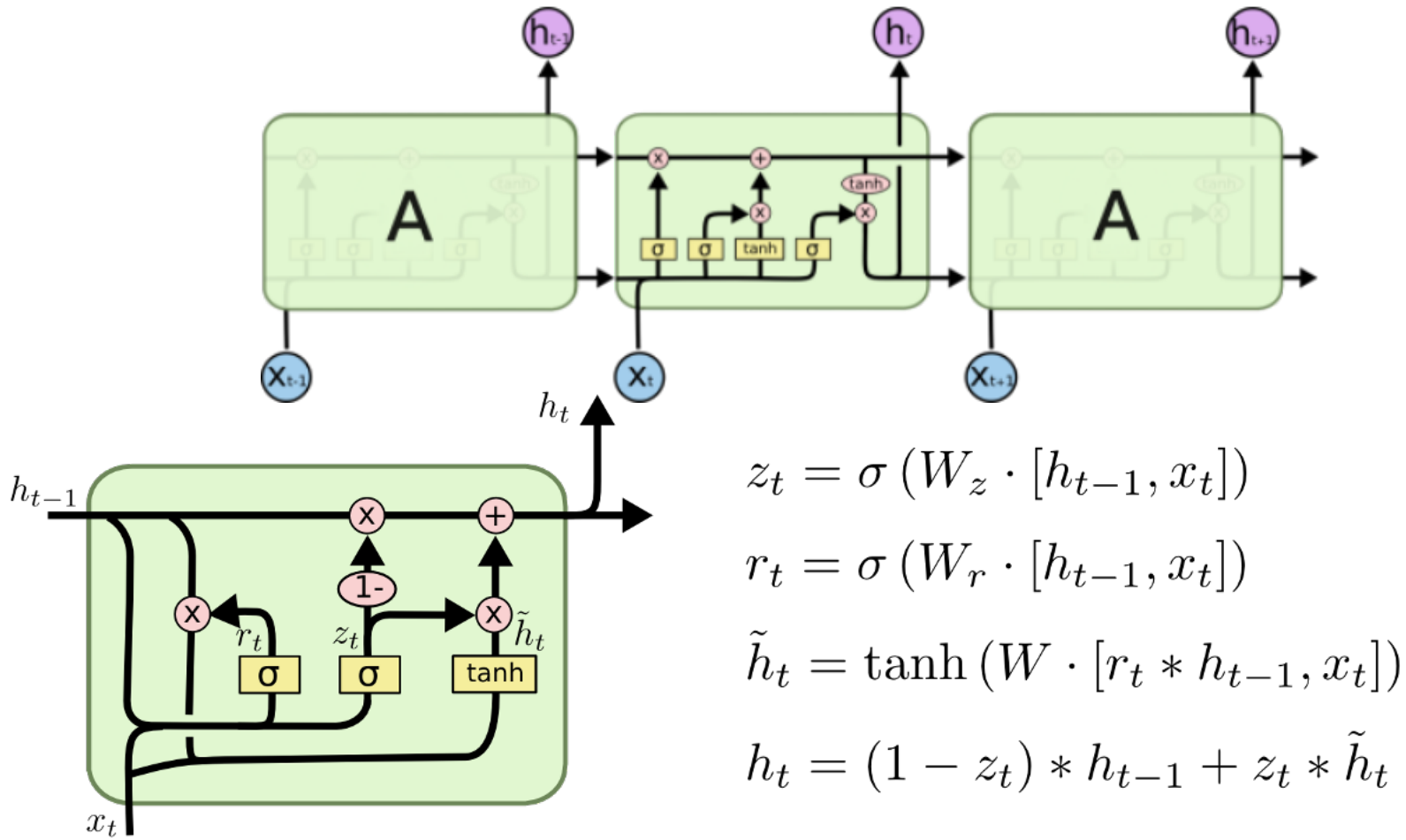

$$z_t = \sigma(W_z \cdot [h_{t-1}, x_t])$$

$$r_t = \sigma(W_r \cdot [h_{t-1}, x_t])$$

$$\tilde{h}_t = \tanh(W \cdot [r_t * h_{t-1}, x_t])$$

$$h_t = (1 - z_t) * h_{t-1} + z_t * \tilde{h}_t$$

LSTM application: language model

- Autoregressive language model: $P(X; \theta) = \prod_{t=1}^L P(X_t | X_{i < t}; \theta)$
 - X : a sentence
 - Sequential generation
- LSTM language model
 - X_t : word at position t .
 - Y_t : softmax over all words
- Data: a collection of texts:
 - Wiki

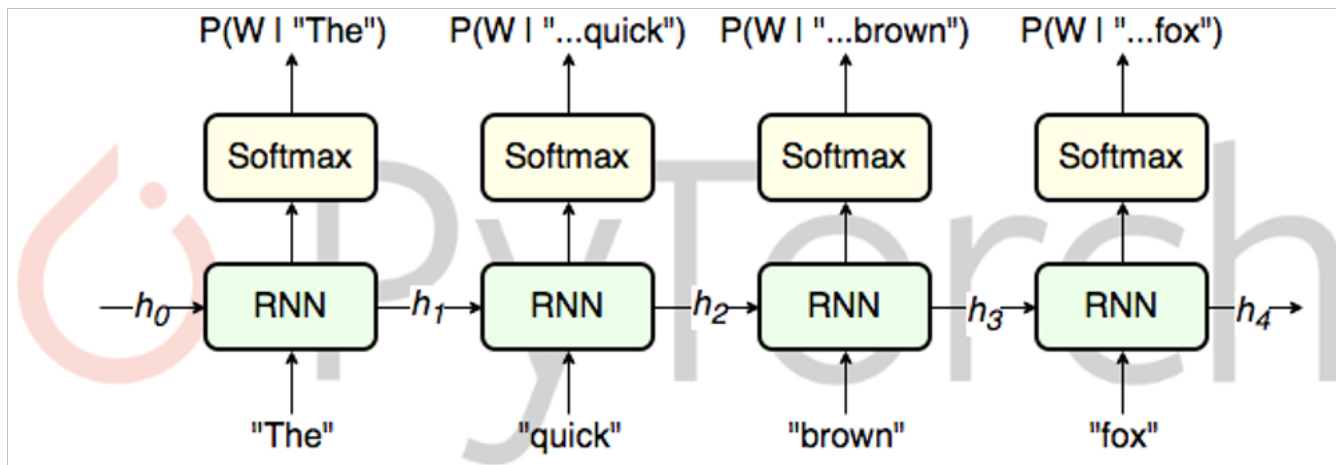

LSTM application: text classification

Bi-directional LSTM and then run softmax on the final hidden state.

