

Lecture 7: Training Neural Networks, Part II

Administrative: Assignment 2

Has been released

Due 10/22 11:59pm

- Multi-layer Neural Networks,
- Image Features,
- Optimizers

Administrative: Course Project

Groups assigned

Proposal due 2/29

Come to OH to talk about projects

Last time: Activation Functions

Sigmoid

$$\sigma(x) = \frac{1}{1+e^{-x}}$$

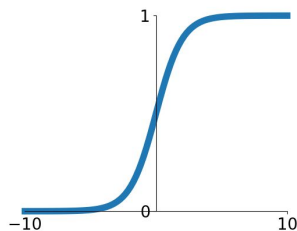

tanh

$$\tanh(x)$$

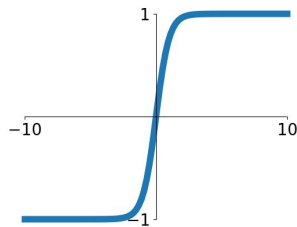

ReLU

$$\max(0, x)$$

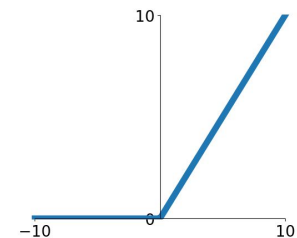

Leaky ReLU

$$\max(0.1x, x)$$

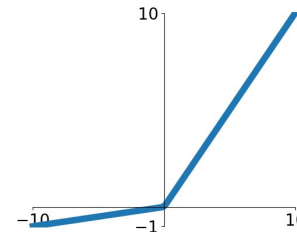

Maxout

$$\max(w_1^T x + b_1, w_2^T x + b_2)$$

ELU

$$\begin{cases} x & x \geq 0 \\ \alpha(e^x - 1) & x < 0 \end{cases}$$

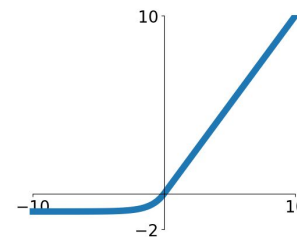

Last time: Activation Functions

Sigmoid

$$\sigma(x) = \frac{1}{1+e^{-x}}$$

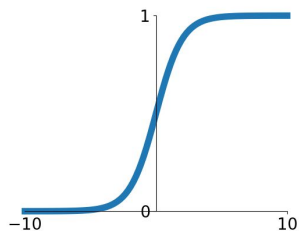

tanh

$$\tanh(x)$$

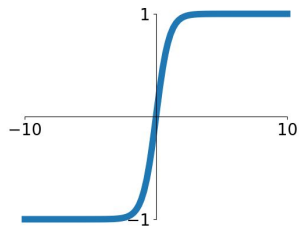

ReLU

$$\max(0, x)$$

Good default choice

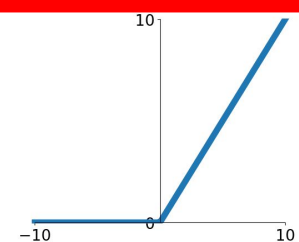

Leaky ReLU

$$\max(0.1x, x)$$

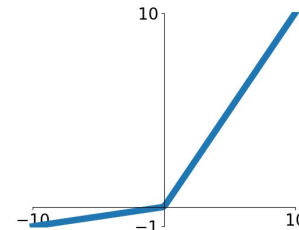

Maxout

$$\max(w_1^T x + b_1, w_2^T x + b_2)$$

ELU

$$\begin{cases} x & x \geq 0 \\ \alpha(e^x - 1) & x < 0 \end{cases}$$

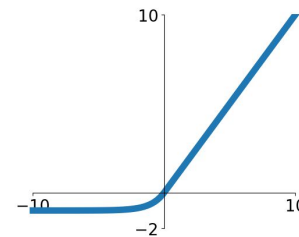

Last time: Weight Initialization

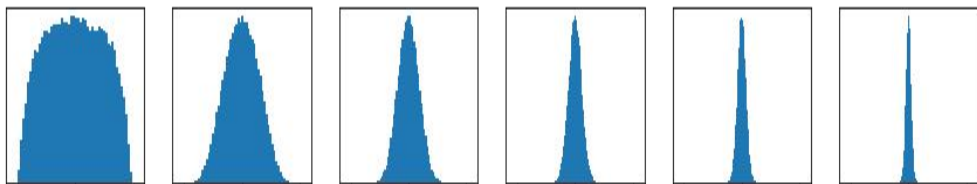

Initialization too small:

Activations go to zero, gradients also zero,
No learning =(

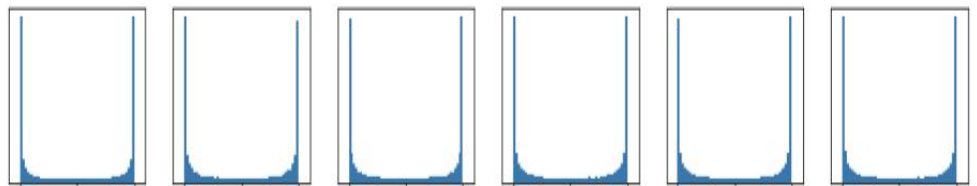

Initialization too big:

Activations saturate (for tanh),
Gradients zero, no learning =(

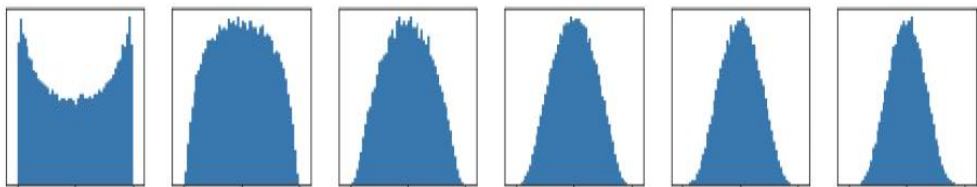

Initialization just right:

Nice distribution of activations at all layers,
Learning proceeds nicely =)

Last time: Data Preprocessing

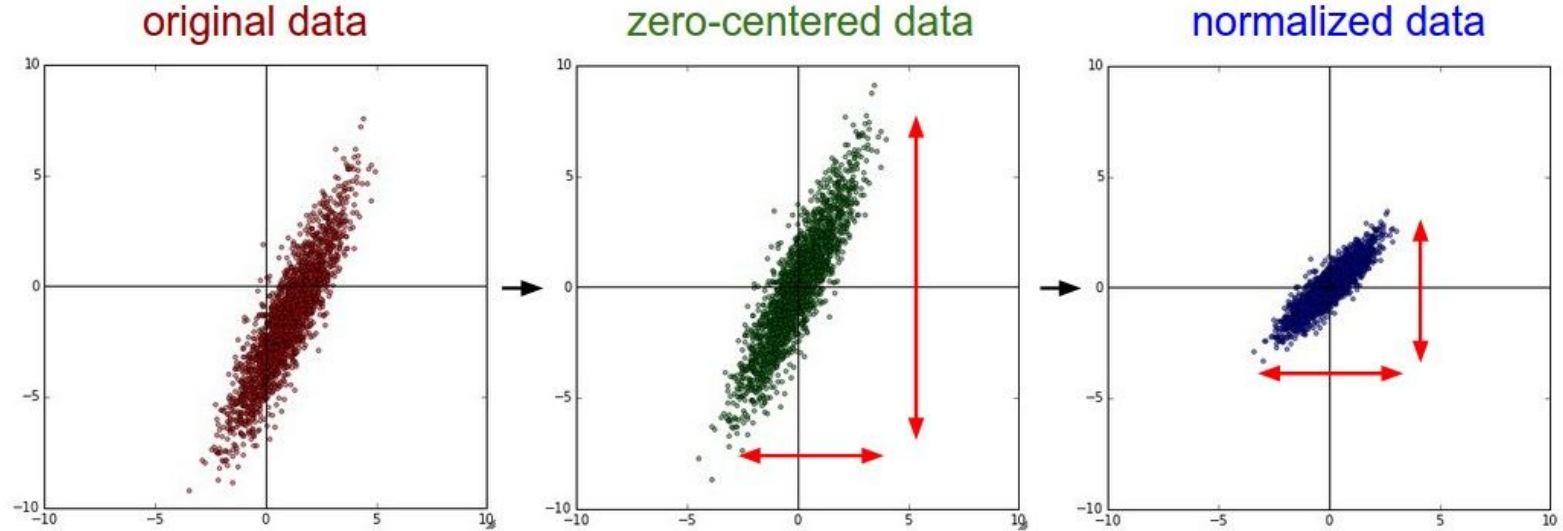

Last Time: Batch Normalization

[Ioffe and Szegedy, 2015]

Input: $x : N \times D$

$$\mu_j = \frac{1}{N} \sum_{i=1}^N x_{i,j}$$

Per-channel mean,
shape is D

**Learnable scale and
shift parameters:**

$$\gamma, \beta : D$$

$$\sigma_j^2 = \frac{1}{N} \sum_{i=1}^N (x_{i,j} - \mu_j)^2$$

Per-channel var,
shape is D

Learning $\gamma = \sigma$,
 $\beta = \mu$ will recover the
identity function!

$$\hat{x}_{i,j} = \frac{x_{i,j} - \mu_j}{\sqrt{\sigma_j^2 + \epsilon}}$$

Normalized x,
Shape is N x D

$$y_{i,j} = \gamma_j \hat{x}_{i,j} + \beta_j$$

Output,
Shape is N x D

Batch Normalization: Test-Time

Input: $x : N \times D$

$$\mu_j = \text{(Running) average of values seen during training}$$

Per-channel mean, shape is D

Learnable scale and shift parameters:

$$\gamma, \beta : D$$

$$\sigma_j^2 = \text{(Running) average of values seen during training}$$

Per-channel var, shape is D

During testing batchnorm becomes a linear operator!
Can be fused with the previous fully-connected or conv layer

$$\hat{x}_{i,j} = \frac{x_{i,j} - \mu_j}{\sqrt{\sigma_j^2 + \epsilon}}$$

Normalized x, Shape is N x D

$$y_{i,j} = \gamma_j \hat{x}_{i,j} + \beta_j$$

Output, Shape is N x D

Batch Normalization

[Ioffe and Szegedy, 2015]

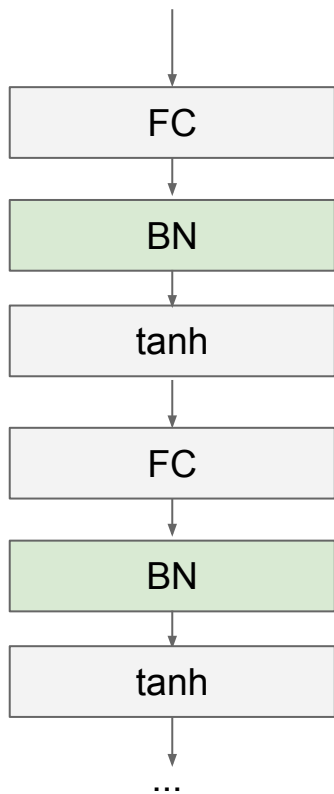

Usually inserted after Fully Connected or Convolutional layers, and before nonlinearity.

$$\hat{x}^{(k)} = \frac{x^{(k)} - \mathbb{E}[x^{(k)}]}{\sqrt{\text{Var}[x^{(k)}]}}$$

Batch Normalization

[Ioffe and Szegedy, 2015]

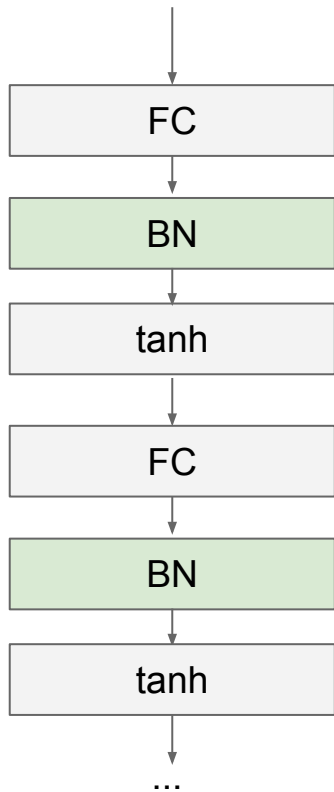

- Makes deep networks **much** easier to train!
- Improves gradient flow
- Allows higher learning rates, faster convergence
- Networks become more robust to initialization
- Acts as regularization during training
- Zero overhead at test-time: can be fused with conv!
- **Behaves differently during training and testing: this is a very common source of bugs!**

Batch Normalization for ConvNets

Batch Normalization for
fully-connected networks

$$\mathbf{x} : \mathbf{N} \times \mathbf{D}$$

Normalize 

$$\boldsymbol{\mu}, \boldsymbol{\sigma} : \mathbf{1} \times \mathbf{D}$$

$$\boldsymbol{\gamma}, \boldsymbol{\beta} : \mathbf{1} \times \mathbf{D}$$

$$\mathbf{y} = \boldsymbol{\gamma} (\mathbf{x} - \boldsymbol{\mu}) / \boldsymbol{\sigma} + \boldsymbol{\beta}$$

Batch Normalization for
convolutional networks
(Spatial Batchnorm, BatchNorm2D)

$$\mathbf{x} : \mathbf{N} \times \mathbf{C} \times \mathbf{H} \times \mathbf{W}$$

Normalize   

$$\boldsymbol{\mu}, \boldsymbol{\sigma} : \mathbf{1} \times \mathbf{C} \times \mathbf{1} \times \mathbf{1}$$

$$\boldsymbol{\gamma}, \boldsymbol{\beta} : \mathbf{1} \times \mathbf{C} \times \mathbf{1} \times \mathbf{1}$$

$$\mathbf{y} = \boldsymbol{\gamma} (\mathbf{x} - \boldsymbol{\mu}) / \boldsymbol{\sigma} + \boldsymbol{\beta}$$

Layer Normalization

Batch Normalization for fully-connected networks

$$\mathbf{x}: \mathbf{N} \times \mathbf{D}$$

Normalize



$$\boldsymbol{\mu}, \boldsymbol{\sigma}: \mathbf{1} \times \mathbf{D}$$

$$\boldsymbol{\gamma}, \boldsymbol{\beta}: \mathbf{1} \times \mathbf{D}$$

$$\mathbf{y} = \boldsymbol{\gamma} (\mathbf{x} - \boldsymbol{\mu}) / \boldsymbol{\sigma} + \boldsymbol{\beta}$$

Layer Normalization for fully-connected networks
Same behavior at train and test!
Can be used in recurrent networks

$$\mathbf{x}: \mathbf{N} \times \mathbf{D}$$

Normalize



$$\boldsymbol{\mu}, \boldsymbol{\sigma}: \mathbf{N} \times \mathbf{1}$$

$$\boldsymbol{\gamma}, \boldsymbol{\beta}: \mathbf{1} \times \mathbf{D}$$

$$\mathbf{y} = \boldsymbol{\gamma} (\mathbf{x} - \boldsymbol{\mu}) / \boldsymbol{\sigma} + \boldsymbol{\beta}$$

Ba, Kiros, and Hinton, "Layer Normalization", arXiv 2016

Instance Normalization

Batch Normalization for convolutional networks

$$\begin{array}{l} \mathbf{x} : \mathbf{N} \times \mathbf{C} \times \mathbf{H} \times \mathbf{W} \\ \text{Normalize} \quad \downarrow \quad \downarrow \quad \downarrow \\ \boldsymbol{\mu}, \boldsymbol{\sigma} : \mathbf{1} \times \mathbf{C} \times \mathbf{1} \times \mathbf{1} \\ \boldsymbol{\gamma}, \boldsymbol{\beta} : \mathbf{1} \times \mathbf{C} \times \mathbf{1} \times \mathbf{1} \\ \mathbf{y} = \boldsymbol{\gamma} (\mathbf{x} - \boldsymbol{\mu}) / \boldsymbol{\sigma} + \boldsymbol{\beta} \end{array}$$

Instance Normalization for convolutional networks
Same behavior at train / test!

$$\begin{array}{l} \mathbf{x} : \mathbf{N} \times \mathbf{C} \times \mathbf{H} \times \mathbf{W} \\ \text{Normalize} \quad \quad \quad \downarrow \quad \downarrow \\ \boldsymbol{\mu}, \boldsymbol{\sigma} : \mathbf{N} \times \mathbf{C} \times \mathbf{1} \times \mathbf{1} \\ \boldsymbol{\gamma}, \boldsymbol{\beta} : \mathbf{1} \times \mathbf{C} \times \mathbf{1} \times \mathbf{1} \\ \mathbf{y} = \boldsymbol{\gamma} (\mathbf{x} - \boldsymbol{\mu}) / \boldsymbol{\sigma} + \boldsymbol{\beta} \end{array}$$

Ulyanov et al, Improved Texture Networks: Maximizing Quality and Diversity in Feed-forward Stylization and Texture Synthesis, CVPR 2017

Comparison of Normalization Layers

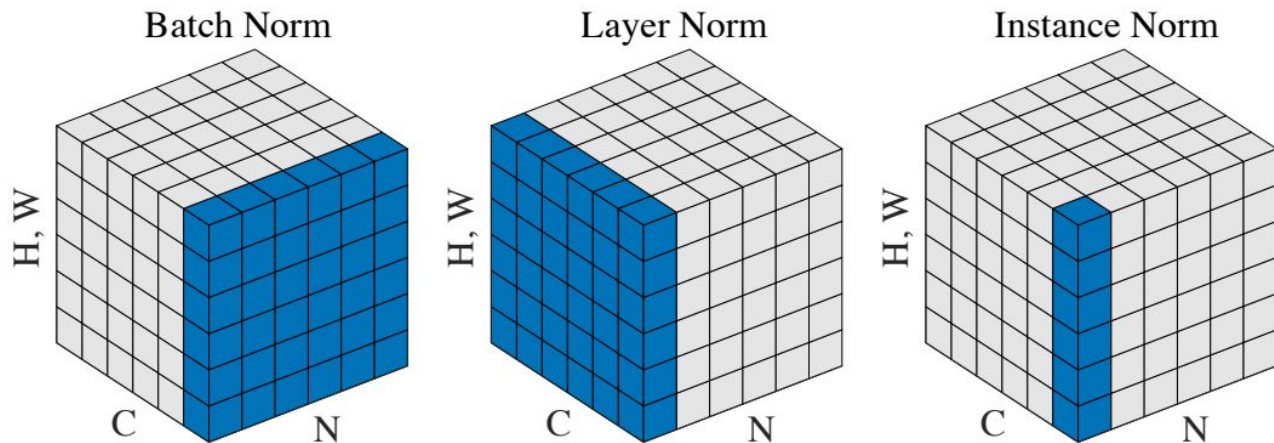

Wu and He, "Group Normalization", ECCV 2018

Group Normalization

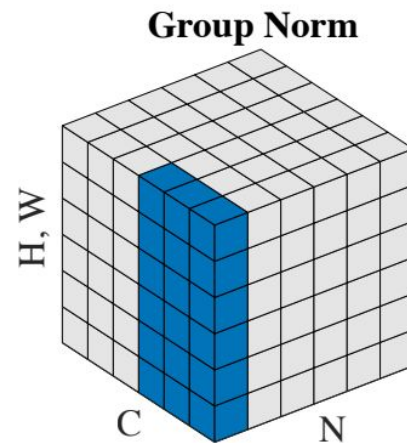
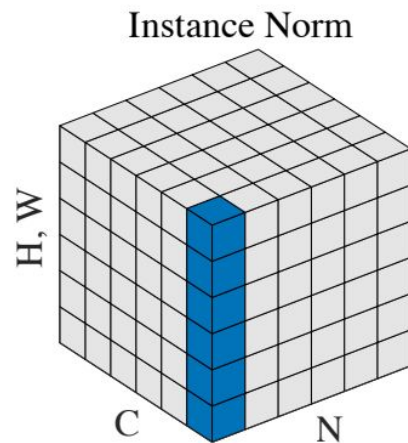
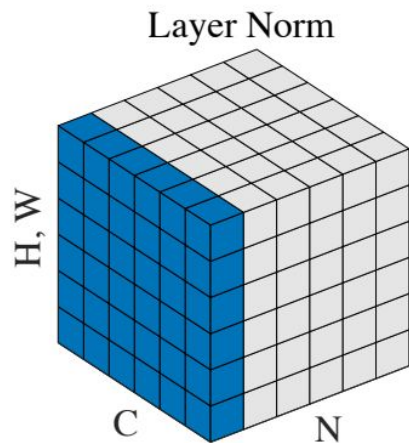
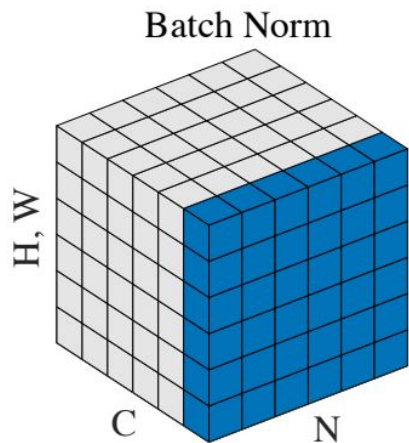

Wu and He, "Group Normalization", ECCV 2018

Today

- Improve your training error:
 - (Fancier) Optimizers
 - Learning rate schedules
- Improve your test error:
 - Regularization
 - Choosing Hyperparameters

(Fancier) Optimizers

Optimization

```
# Vanilla Gradient Descent
```

```
while True:
```

```
    weights_grad = evaluate_gradient(loss_fun, data, weights)
```

```
    weights += - step_size * weights_grad # perform parameter update
```

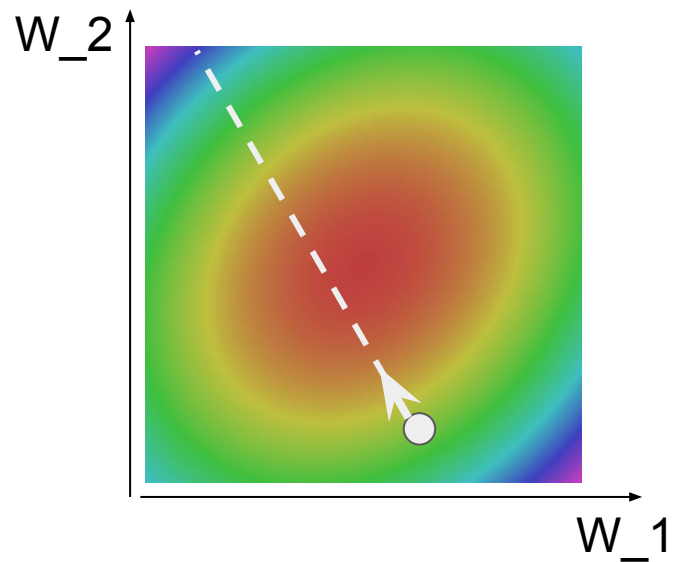

Optimization: Problem #1 with SGD

What if loss changes quickly in one direction and slowly in another?
What does gradient descent do?

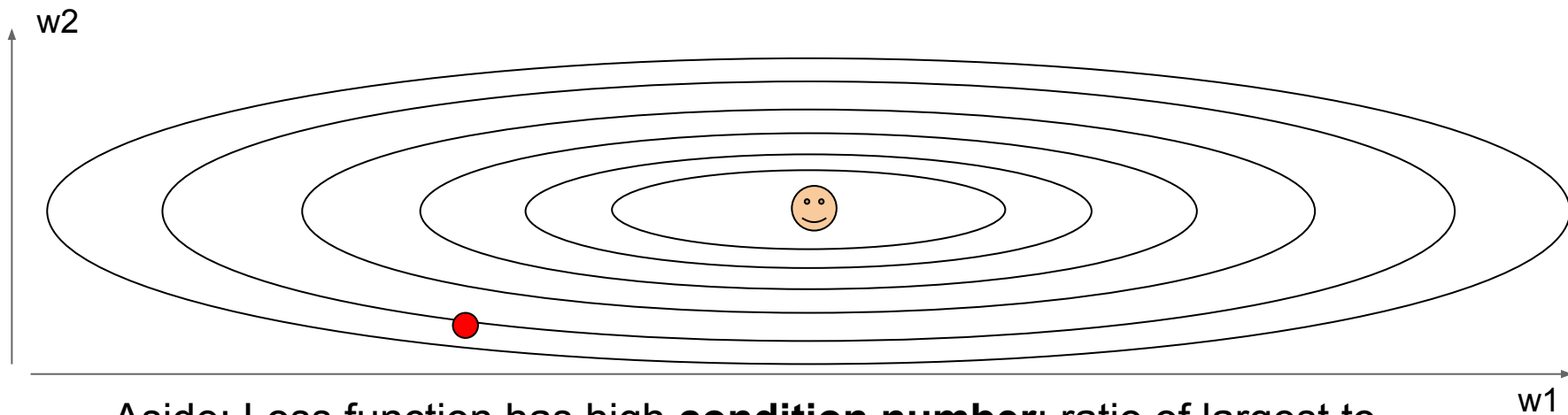

Aside: Loss function has high **condition number**: ratio of largest to smallest singular value of the Hessian matrix is large

Optimization: Problem #1 with SGD

What if loss changes quickly in one direction and slowly in another?
What does gradient descent do?

Very slow progress along shallow dimension, jitter along steep direction

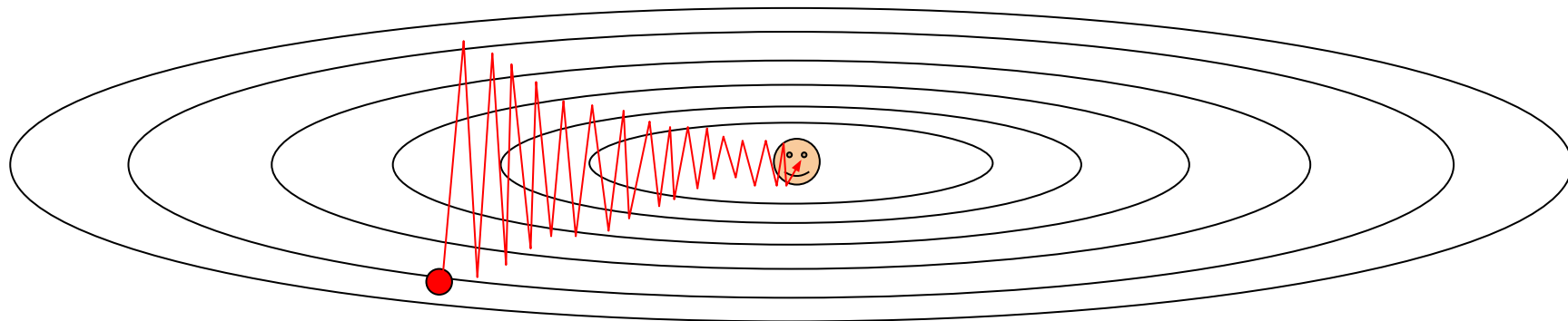

Loss function has high **condition number**: ratio of largest to smallest singular value of the Hessian matrix is large

Optimization: Problem #2 with SGD

What if the loss function has a **local minima** or **saddle point**?

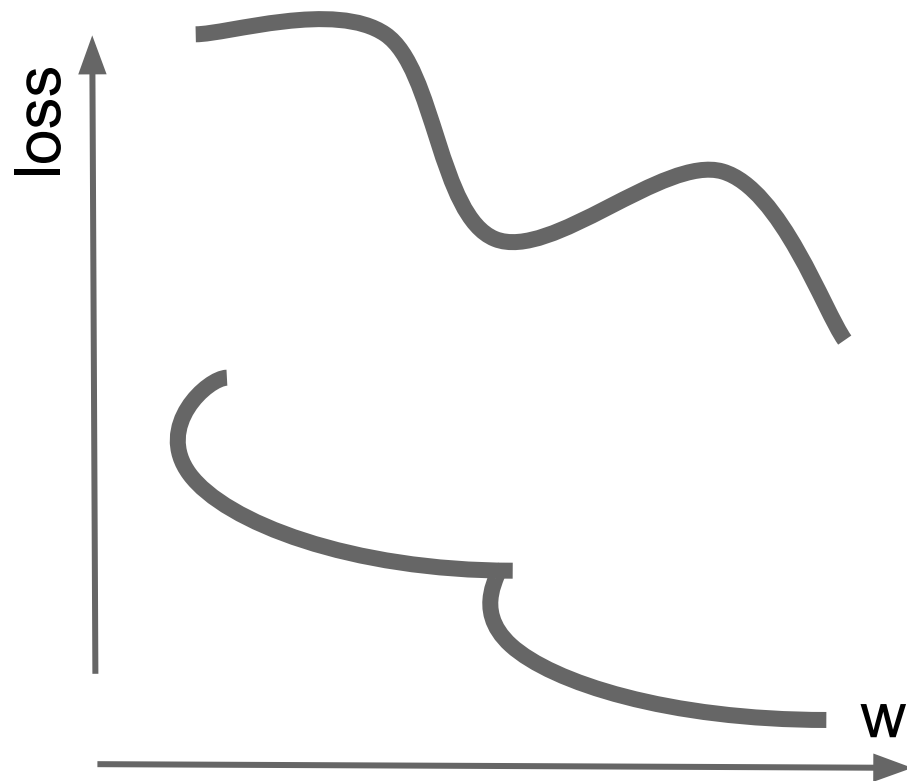

Optimization: Problem #2 with SGD

What if the loss function has a **local minima** or **saddle point**?

Zero gradient,
gradient descent
gets stuck

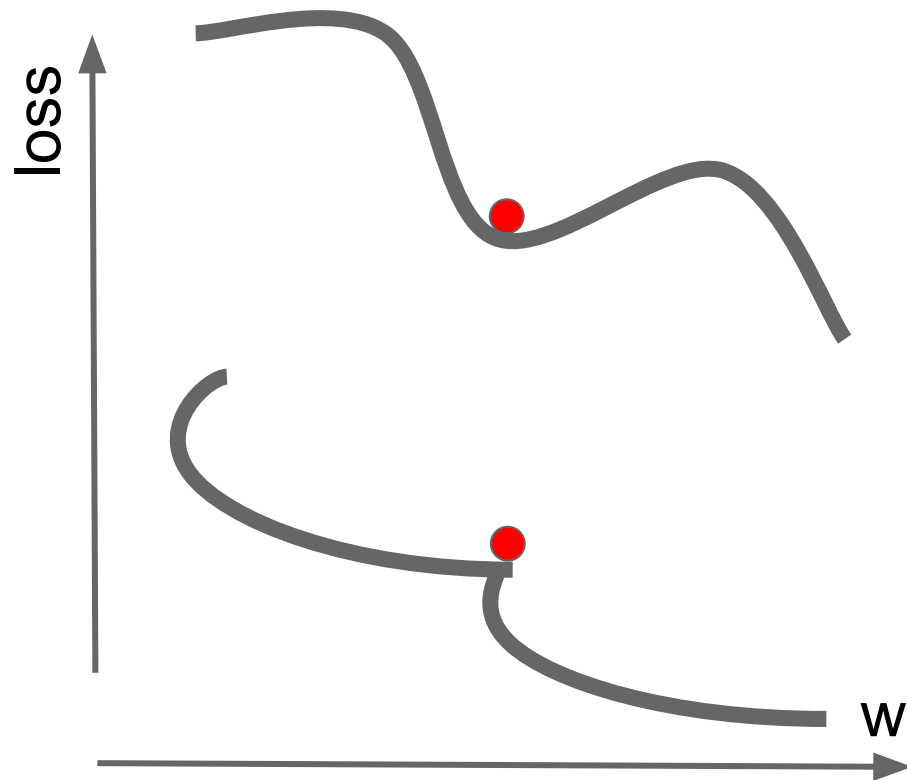

Optimization: Problem #2 with SGD

What if the loss function has a **local minima** or **saddle point**?

Saddle points much more common in high dimension

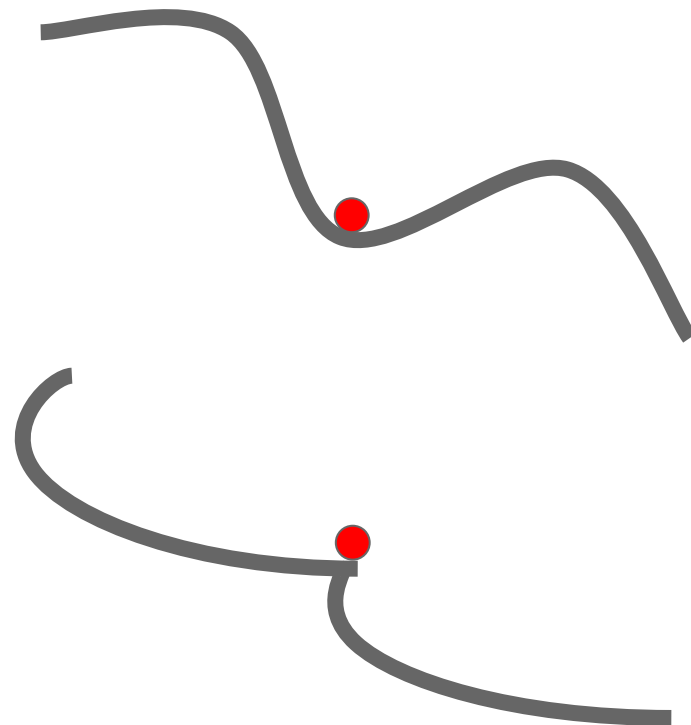

Dauphin et al, "Identifying and attacking the saddle point problem in high-dimensional non-convex optimization", NIPS 2014

Optimization: Problem #3 with SGD

Our gradients come from minibatches so they can be noisy!

$$L(W) = \frac{1}{N} \sum_{i=1}^N L_i(x_i, y_i, W)$$

$$\nabla_W L(W) = \frac{1}{N} \sum_{i=1}^N \nabla_W L_i(x_i, y_i, W)$$

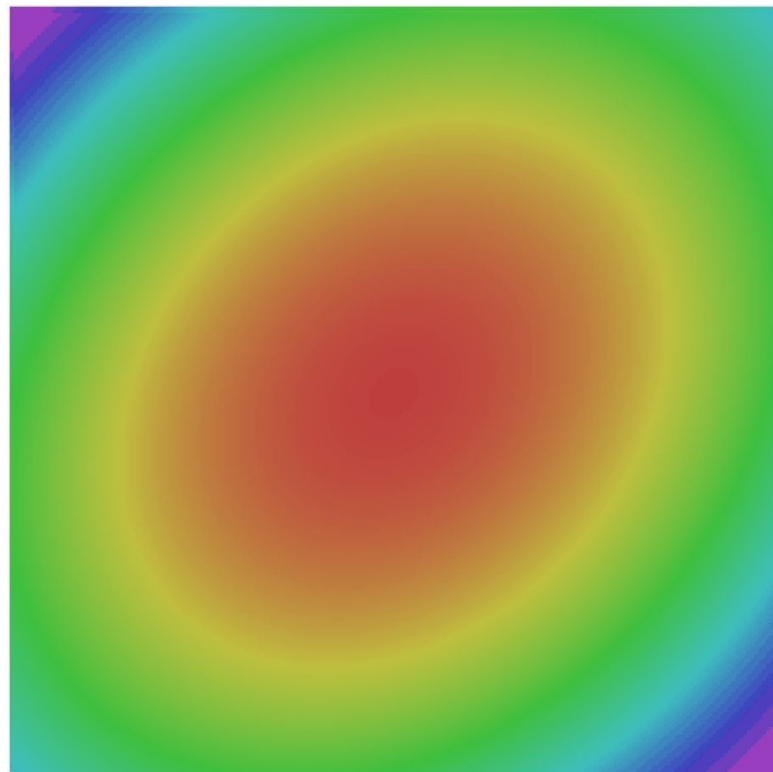

SGD + Momentum

Local Minima

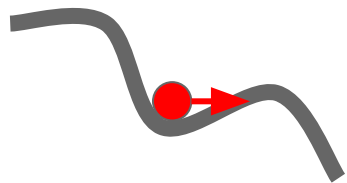

Saddle points

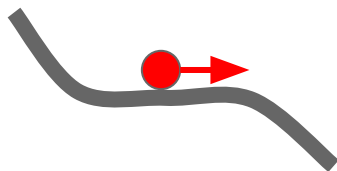

Poor Conditioning

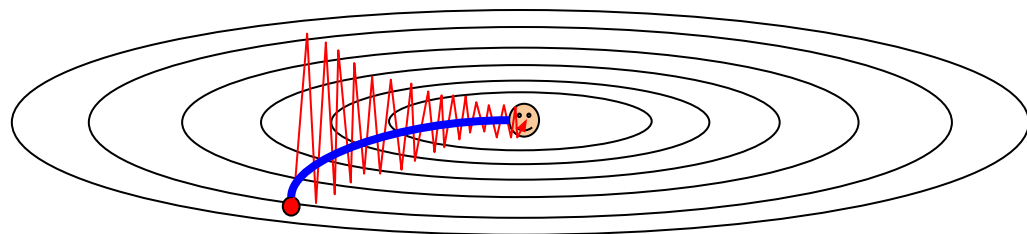

Gradient Noise

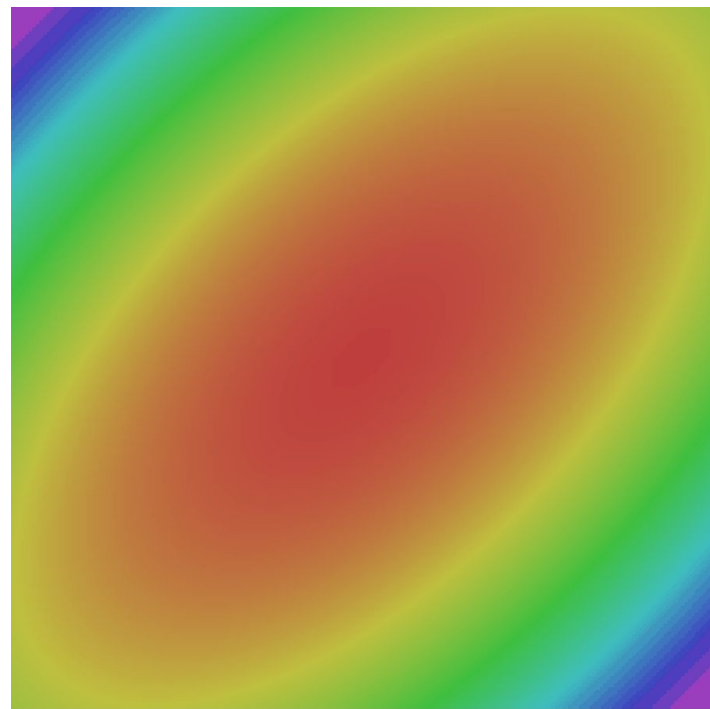

— SGD

— SGD+Momentum

SGD: the simple two line update code

SGD

$$x_{t+1} = x_t - \alpha \nabla f(x_t)$$

```
while True:  
    dx = compute_gradient(x)  
    x -= learning_rate * dx
```

SGD + Momentum:

continue moving in the general direction as the previous iterations

SGD

$$x_{t+1} = x_t - \alpha \nabla f(x_t)$$

```
while True:
    dx = compute_gradient(x)
    x -= learning_rate * dx
```

SGD+Momentum

$$v_{t+1} = \rho v_t + \nabla f(x_t)$$

$$x_{t+1} = x_t - \alpha v_{t+1}$$

- Build up “velocity” as a running mean of gradients
- Rho gives “friction”; typically rho=0.9 or 0.99

Sutskever et al, “On the importance of initialization and momentum in deep learning”, ICML 2013

SGD + Momentum:

continue moving in the general direction as the previous iterations

SGD

$$x_{t+1} = x_t - \alpha \nabla f(x_t)$$

```
while True:
    dx = compute_gradient(x)
    x -= learning_rate * dx
```

SGD+Momentum

$$v_{t+1} = \rho v_t + \nabla f(x_t)$$

$$x_{t+1} = x_t - \alpha v_{t+1}$$

```
vx = 0
while True:
    dx = compute_gradient(x)
    vx = rho * vx + dx
    x -= learning_rate * vx
```

- Build up “velocity” as a running mean of gradients
- Rho gives “friction”; typically rho=0.9 or 0.99

Sutskever et al, “On the importance of initialization and momentum in deep learning”, ICML 2013

SGD + Momentum:

alternative equivalent formulation

SGD+Momentum

$$v_{t+1} = \rho v_t - \alpha \nabla f(x_t)$$

$$x_{t+1} = x_t + v_{t+1}$$

```
vx = 0
while True:
    dx = compute_gradient(x)
    vx = rho * vx - learning_rate * dx
    x += vx
```

SGD+Momentum

$$v_{t+1} = \rho v_t + \nabla f(x_t)$$

$$x_{t+1} = x_t - \alpha v_{t+1}$$

```
vx = 0
while True:
    dx = compute_gradient(x)
    vx = rho * vx + dx
    x -= learning_rate * vx
```

You may see SGD+Momentum formulated different ways,
but they are equivalent - give same sequence of x

SGD+Momentum

Momentum update:

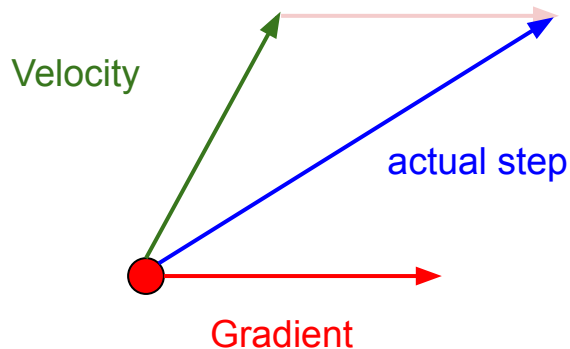

Combine gradient at current point with velocity to get step used to update weights

Nesterov, "A method of solving a convex programming problem with convergence rate $O(1/k^2)$ ", 1983

Nesterov, "Introductory lectures on convex optimization: a basic course", 2004

Sutskever et al, "On the importance of initialization and momentum in deep learning", ICML 2013

Nesterov Momentum

Momentum update:

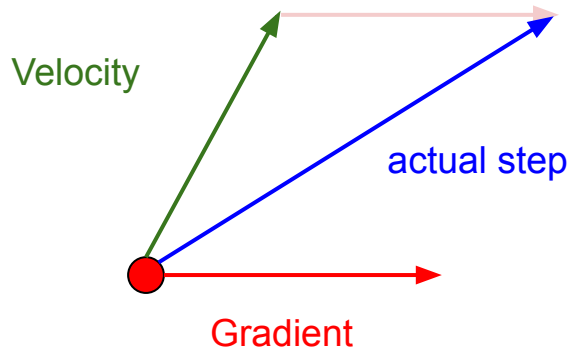

Combine gradient at current point with velocity to get step used to update weights

Nesterov Momentum

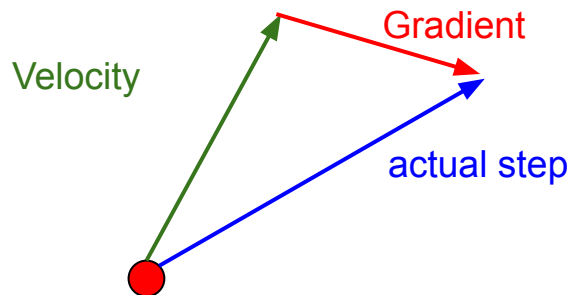

“Look ahead” to the point where updating using velocity would take us; compute gradient there and mix it with velocity to get actual update direction

Nesterov, “A method of solving a convex programming problem with convergence rate $O(1/k^2)$ ”, 1983
Nesterov, “Introductory lectures on convex optimization: a basic course”, 2004
Sutskever et al, “On the importance of initialization and momentum in deep learning”, ICML 2013

Nesterov Momentum

$$v_{t+1} = \rho v_t - \alpha \nabla f(x_t + \rho v_t)$$

$$x_{t+1} = x_t + v_{t+1}$$

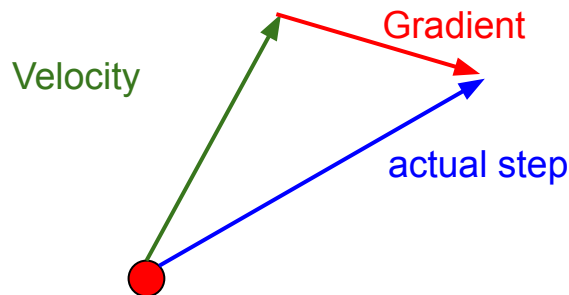

“Look ahead” to the point where updating using velocity would take us; compute gradient there and mix it with velocity to get actual update direction

Nesterov Momentum

$$v_{t+1} = \rho v_t - \alpha \nabla f(x_t + \rho v_t)$$

$$x_{t+1} = x_t + v_{t+1}$$

Annoying, usually we want update in terms of $x_t, \nabla f(x_t)$

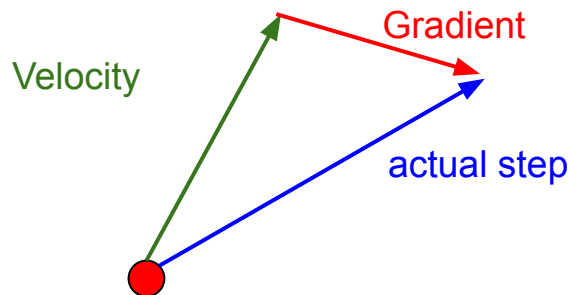

“Look ahead” to the point where updating using velocity would take us; compute gradient there and mix it with velocity to get actual update direction

Nesterov Momentum

$$v_{t+1} = \rho v_t - \alpha \nabla f(x_t + \rho v_t)$$

$$x_{t+1} = x_t + v_{t+1}$$

Change of variables $\tilde{x}_t = x_t + \rho v_t$ and rearrange:

Annoying, usually we want update in terms of $x_t, \nabla f(x_t)$

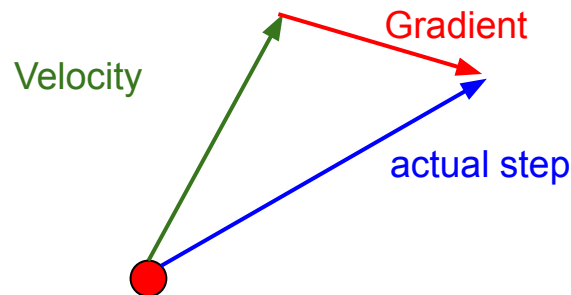

“Look ahead” to the point where updating using velocity would take us; compute gradient there and mix it with velocity to get actual update direction

Nesterov Momentum

$$v_{t+1} = \rho v_t - \alpha \nabla f(x_t + \rho v_t)$$

$$x_{t+1} = x_t + v_{t+1}$$

Change of variables $\tilde{x}_t = x_t + \rho v_t$ and rearrange:

$$v_{t+1} = \rho v_t - \alpha \nabla f(\tilde{x}_t)$$

$$\begin{aligned}\tilde{x}_{t+1} &= \tilde{x}_t - \rho v_t + (1 + \rho)v_{t+1} \\ &= \tilde{x}_t + v_{t+1} + \rho(v_{t+1} - v_t)\end{aligned}$$

Annoying, usually we want update in terms of $x_t, \nabla f(x_t)$

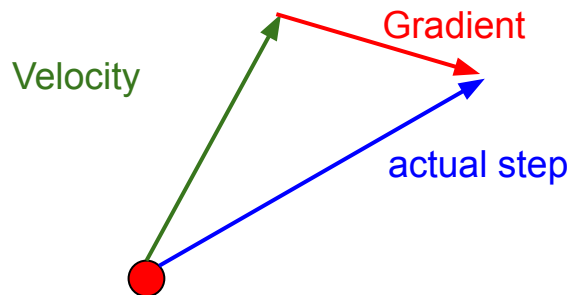

“Look ahead” to the point where updating using velocity would take us; compute gradient there and mix it with velocity to get actual update direction

Nesterov Momentum

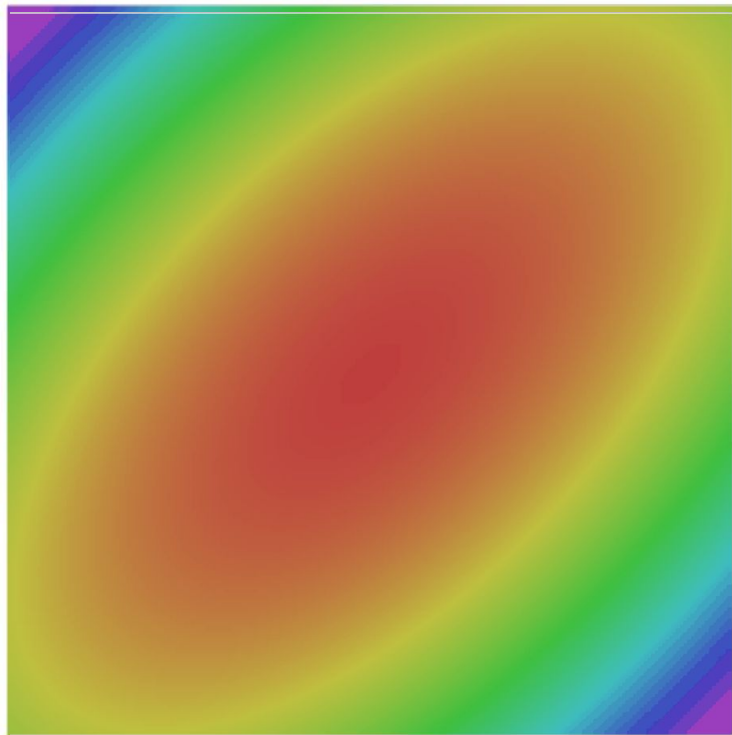

- SGD
- SGD+Momentum
- Nesterov

AdaGrad

```
grad_squared = 0
while True:
    dx = compute_gradient(x)
    grad_squared += dx * dx
    x -= learning_rate * dx / (np.sqrt(grad_squared) + 1e-7)
```

Added element-wise scaling of the gradient based on the historical sum of squares in each dimension

“Per-parameter learning rates”
or “adaptive learning rates”

AdaGrad

```
grad_squared = 0
while True:
    dx = compute_gradient(x)
    grad_squared += dx * dx
    x -= learning_rate * dx / (np.sqrt(grad_squared) + 1e-7)
```

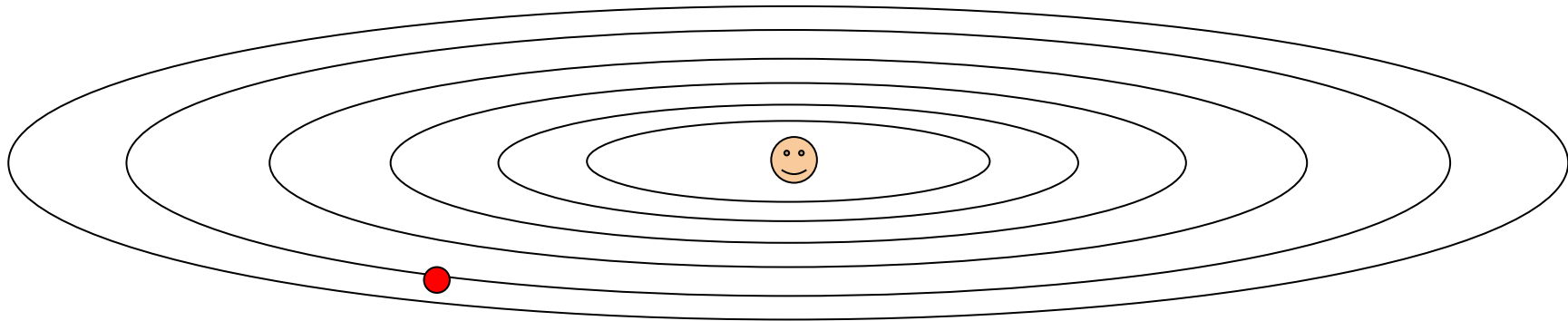

Q: What happens with AdaGrad?

AdaGrad

```
grad_squared = 0
while True:
    dx = compute_gradient(x)
    grad_squared += dx * dx
    x -= learning_rate * dx / (np.sqrt(grad_squared) + 1e-7)
```

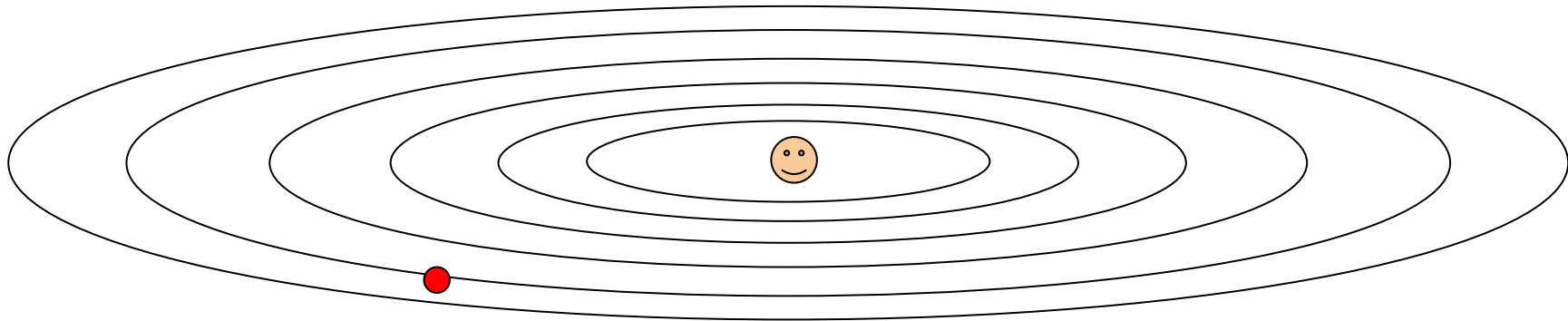

Q: What happens with AdaGrad?

Progress along “steep” directions is damped;
progress along “flat” directions is accelerated

AdaGrad

```
grad_squared = 0
while True:
    dx = compute_gradient(x)
    grad_squared += dx * dx
    x -= learning_rate * dx / (np.sqrt(grad_squared) + 1e-7)
```

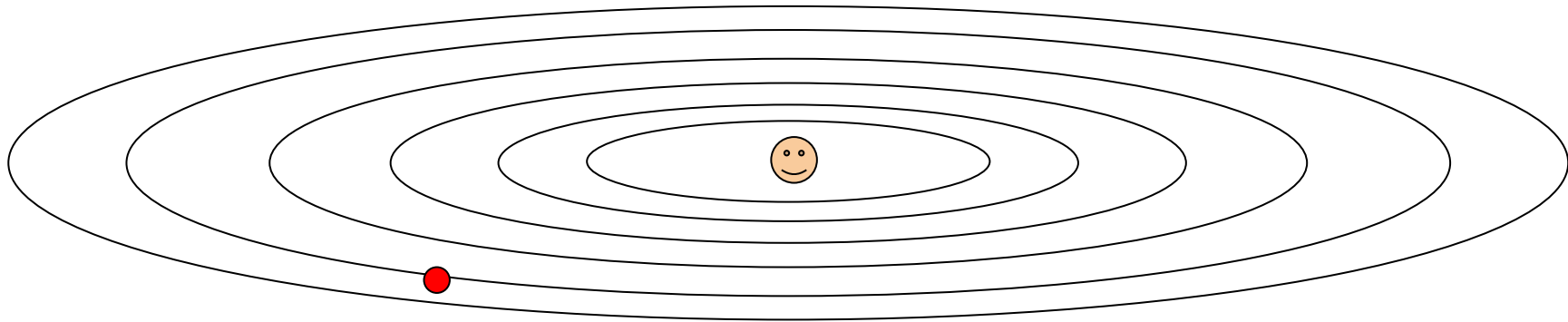

Q2: What happens to the step size over long time?

AdaGrad

```
grad_squared = 0
while True:
    dx = compute_gradient(x)
    grad_squared += dx * dx
    x -= learning_rate * dx / (np.sqrt(grad_squared) + 1e-7)
```

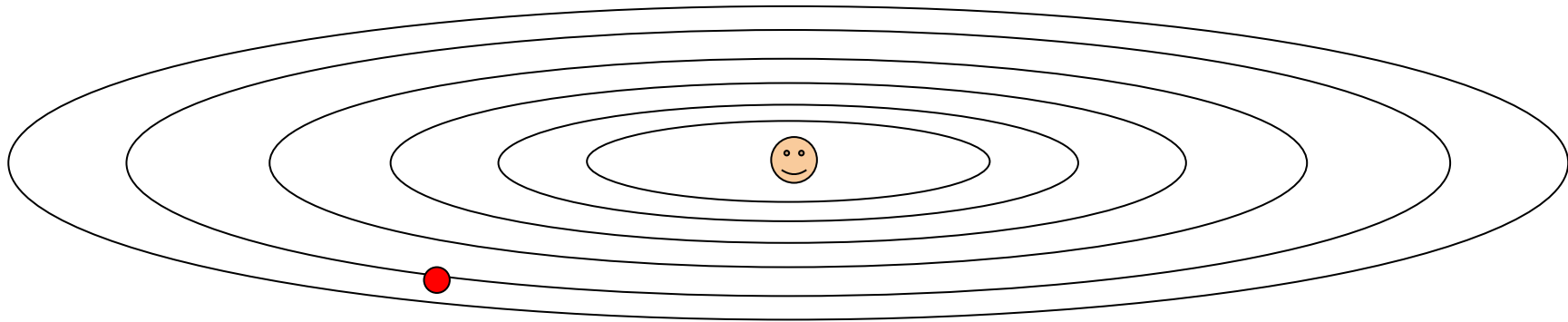

Q2: What happens to the step size over long time? Decays to zero

RMSProp: “Leaky AdaGrad”

AdaGrad

```
grad_squared = 0
while True:
    dx = compute_gradient(x)
    grad_squared += dx * dx
    x -= learning_rate * dx / (np.sqrt(grad_squared) + 1e-7)
```



RMSProp

```
grad_squared = 0
while True:
    dx = compute_gradient(x)
    grad_squared = decay_rate * grad_squared + (1 - decay_rate) * dx * dx
    x -= learning_rate * dx / (np.sqrt(grad_squared) + 1e-7)
```

RMSProp

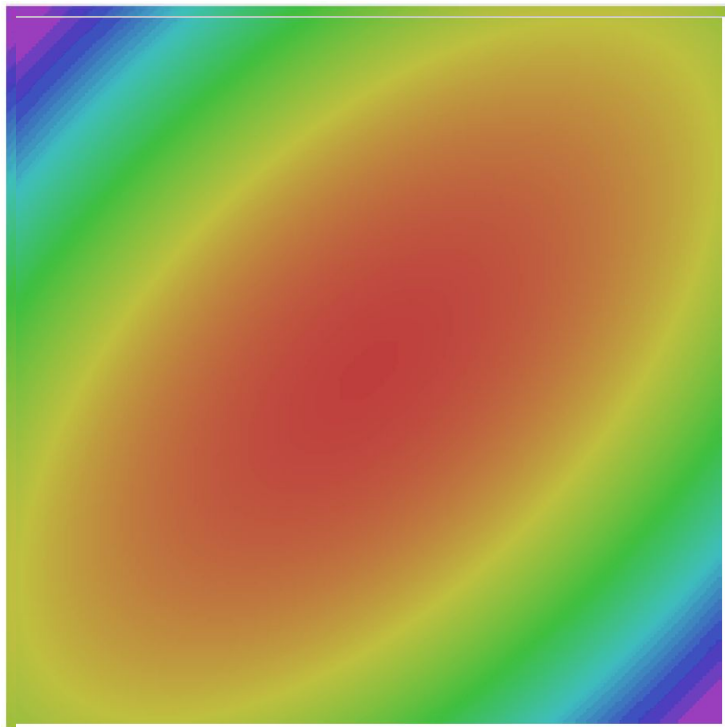

- SGD
- SGD+Momentum
- RMSProp
- AdaGrad
(stuck due to decaying lr)

Adam (almost)

```
first_moment = 0
second_moment = 0
while True:
    dx = compute_gradient(x)
    first_moment = beta1 * first_moment + (1 - beta1) * dx
    second_moment = beta2 * second_moment + (1 - beta2) * dx * dx
    x -= learning_rate * first_moment / (np.sqrt(second_moment) + 1e-7))
```

Kingma and Ba, "Adam: A method for stochastic optimization", ICLR 2015

Adam (almost)

```
first_moment = 0
second_moment = 0
while True:
    dx = compute_gradient(x)
    first_moment = beta1 * first_moment + (1 - beta1) * dx
    second_moment = beta2 * second_moment + (1 - beta2) * dx * dx
    x -= learning_rate * first_moment / (np.sqrt(second_moment) + 1e-7))
```

Momentum

AdaGrad / RMSProp

Sort of like RMSProp with momentum

Q: What happens at first timestep?

Adam (full form)

```
first_moment = 0
second_moment = 0
for t in range(1, num_iterations):
    dx = compute_gradient(x)
    first_moment = beta1 * first_moment + (1 - beta1) * dx
    second_moment = beta2 * second_moment + (1 - beta2) * dx * dx
    first_unbias = first_moment / (1 - beta1 ** t)
    second_unbias = second_moment / (1 - beta2 ** t)
    x -= learning_rate * first_unbias / (np.sqrt(second_unbias) + 1e-7))
```

Momentum

Bias correction

AdaGrad / RMSProp

Bias correction for the fact that
first and second moment
estimates start at zero

Kingma and Ba, "Adam: A method for stochastic optimization", ICLR 2015

Adam (full form)

```
first_moment = 0
second_moment = 0
for t in range(1, num_iterations):
    dx = compute_gradient(x)
    first_moment = beta1 * first_moment + (1 - beta1) * dx
    second_moment = beta2 * second_moment + (1 - beta2) * dx * dx
    first_unbias = first_moment / (1 - beta1 ** t)
    second_unbias = second_moment / (1 - beta2 ** t)
    x -= learning_rate * first_unbias / (np.sqrt(second_unbias) + 1e-7))
```

Momentum

Bias correction

AdaGrad / RMSProp

Bias correction for the fact that first and second moment estimates start at zero

Adam with $\text{beta1} = 0.9$, $\text{beta2} = 0.999$, and $\text{learning_rate} = 1\text{e-}3$ or $5\text{e-}4$ is a great starting point for many models!

Kingma and Ba, "Adam: A method for stochastic optimization", ICLR 2015

Adam

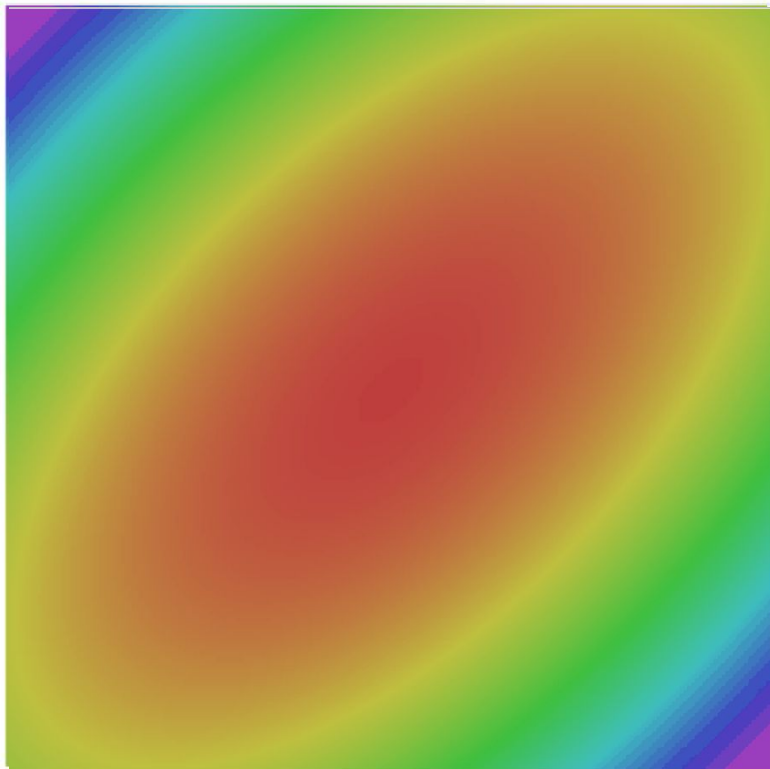

- SGD
- SGD+Momentum
- RMSProp
- Adam

L2 Regularization vs Weight Decay

Optimization Algorithm

$$L(w) = L_{data}(w) + L_{reg}(w)$$

$$g_t = \nabla L(w_t)$$

$$s_t = \text{optimizer}(g_t)$$

$$w_{t+1} = w_t - \alpha s_t$$

L2 Regularization

$$L(w) = L_{data}(w) + \lambda |w|^2$$

$$g_t = \nabla L(w_t) = \nabla L_{data}(w_t) + 2\lambda w_t$$

$$s_t = \text{optimizer}(g_t)$$

$$w_{t+1} = w_t - \alpha s_t$$

L2 Regularization vs Weight Decay

Optimization Algorithm

$$L(w) = L_{data}(w) + L_{reg}(w)$$

$$g_t = \nabla L(w_t)$$

$$s_t = \text{optimizer}(g_t)$$

$$w_{t+1} = w_t - \alpha s_t$$

L2 Regularization and Weight Decay are equivalent for SGD, SGD+Momentum so people often use the terms interchangeably!

L2 Regularization

$$L(w) = L_{data}(w) + \lambda |w|^2$$

$$g_t = \nabla L(w_t) = \nabla L_{data}(w_t) + 2\lambda w_t$$

$$s_t = \text{optimizer}(g_t)$$

$$w_{t+1} = w_t - \alpha s_t$$

Weight Decay

$$L(w) = L_{data}(w)$$

$$g_t = \nabla L_{data}(w_t)$$

$$s_t = \text{optimizer}(g_t) + 2\lambda w_t$$

$$w_{t+1} = w_t - \alpha s_t$$

L2 Regularization vs Weight Decay

Optimization Algorithm

$$L(w) = L_{data}(w) + L_{reg}(w)$$

$$g_t = \nabla L(w_t)$$

$$s_t = \text{optimizer}(g_t)$$

$$w_{t+1} = w_t - \alpha s_t$$

L2 Regularization and Weight Decay are equivalent for SGD, SGD+Momentum so people often use the terms interchangeably!

But they are not the same for adaptive methods (AdaGrad, RMSProp, Adam, etc)

L2 Regularization

$$L(w) = L_{data}(w) + \lambda |w|^2$$

$$g_t = \nabla L(w_t) = \nabla L_{data}(w_t) + 2\lambda w_t$$

$$s_t = \text{optimizer}(g_t)$$

$$w_{t+1} = w_t - \alpha s_t$$

Weight Decay

$$L(w) = L_{data}(w)$$

$$g_t = \nabla L_{data}(w_t)$$

$$s_t = \text{optimizer}(g_t) + 2\lambda w_t$$

$$w_{t+1} = w_t - \alpha s_t$$

AdamW: Decoupled Weight Decay

Algorithm 2 Adam with L_2 regularization and Adam with decoupled weight decay (AdamW)

- 1: **given** $\alpha = 0.001, \beta_1 = 0.9, \beta_2 = 0.999, \epsilon = 10^{-8}, \lambda \in \mathbb{R}$
- 2: **initialize** time step $t \leftarrow 0$, parameter vector $\boldsymbol{\theta}_{t=0} \in \mathbb{R}^n$, first moment vector $\mathbf{m}_{t=0} \leftarrow \mathbf{0}$, second moment vector $\mathbf{v}_{t=0} \leftarrow \mathbf{0}$, schedule multiplier $\eta_{t=0} \in \mathbb{R}$
- 3: **repeat**
- 4: $t \leftarrow t + 1$
- 5: $\nabla f_t(\boldsymbol{\theta}_{t-1}) \leftarrow \text{SelectBatch}(\boldsymbol{\theta}_{t-1})$ ▷ select batch and return the corresponding gradient
- 6: $\mathbf{g}_t \leftarrow \nabla f_t(\boldsymbol{\theta}_{t-1}) + \lambda \boldsymbol{\theta}_{t-1}$
- 7: $\mathbf{m}_t \leftarrow \beta_1 \mathbf{m}_{t-1} + (1 - \beta_1) \mathbf{g}_t$ ▷ here and below all operations are element-wise
- 8: $\mathbf{v}_t \leftarrow \beta_2 \mathbf{v}_{t-1} + (1 - \beta_2) \mathbf{g}_t^2$
- 9: $\hat{\mathbf{m}}_t \leftarrow \mathbf{m}_t / (1 - \beta_1^t)$ ▷ β_1 is taken to the power of t
- 10: $\hat{\mathbf{v}}_t \leftarrow \mathbf{v}_t / (1 - \beta_2^t)$ ▷ β_2 is taken to the power of t
- 11: $\eta_t \leftarrow \text{SetScheduleMultiplier}(t)$ ▷ can be fixed, decay, or also be used for warm restarts
- 12: $\boldsymbol{\theta}_t \leftarrow \boldsymbol{\theta}_{t-1} - \eta_t \left(\alpha \hat{\mathbf{m}}_t / (\sqrt{\hat{\mathbf{v}}_t} + \epsilon) + \lambda \boldsymbol{\theta}_{t-1} \right)$
- 13: **until** *stopping criterion is met*
- 14: **return** optimized parameters $\boldsymbol{\theta}_t$

First-Order Optimization

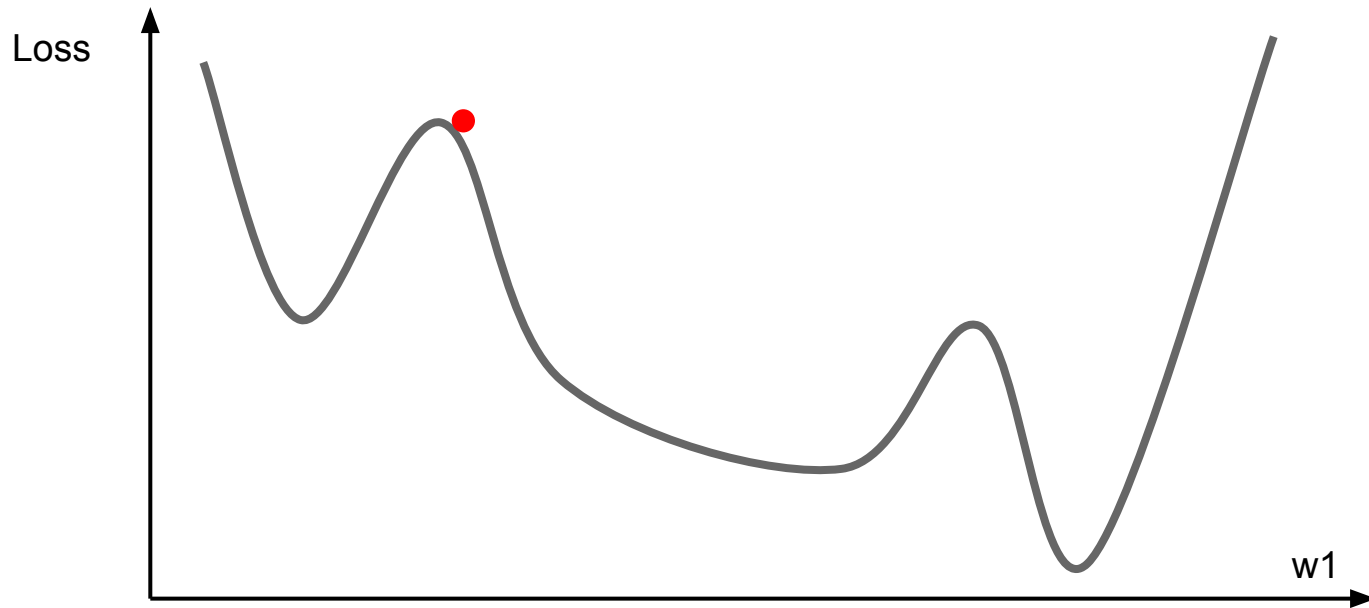

First-Order Optimization

- (1) Use gradient form linear approximation
- (2) Step to minimize the approximation

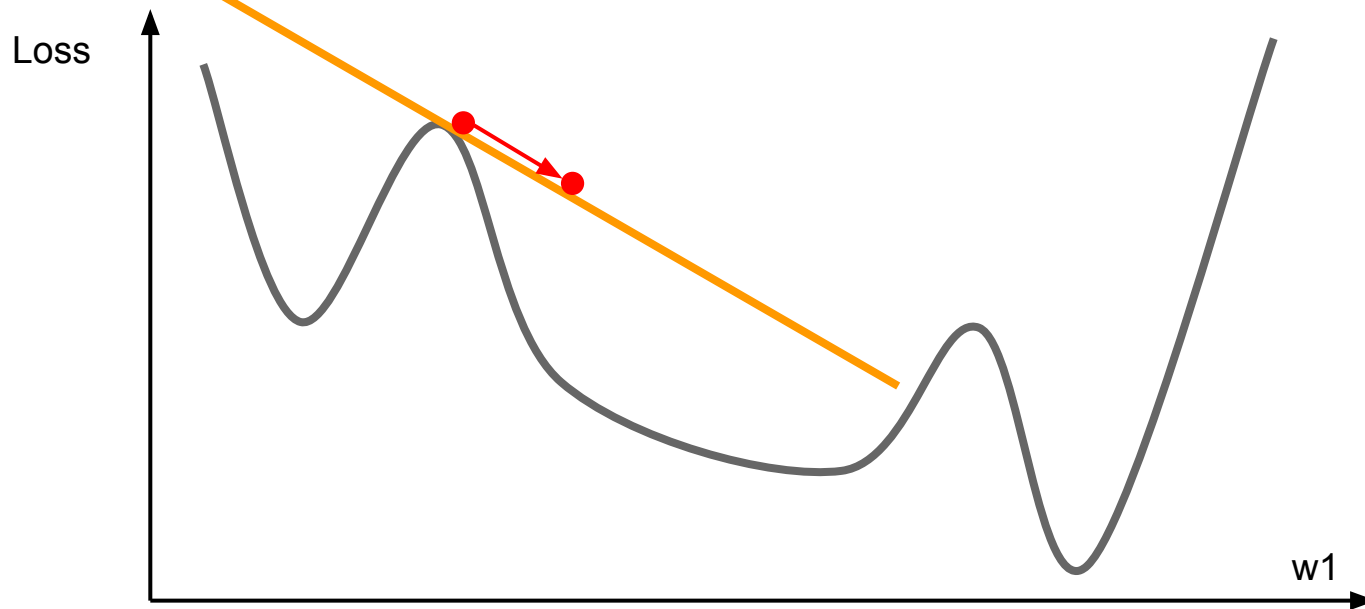

Second-Order Optimization

- (1) Use gradient **and Hessian** to form **quadratic** approximation
- (2) Step to the **minima** of the approximation

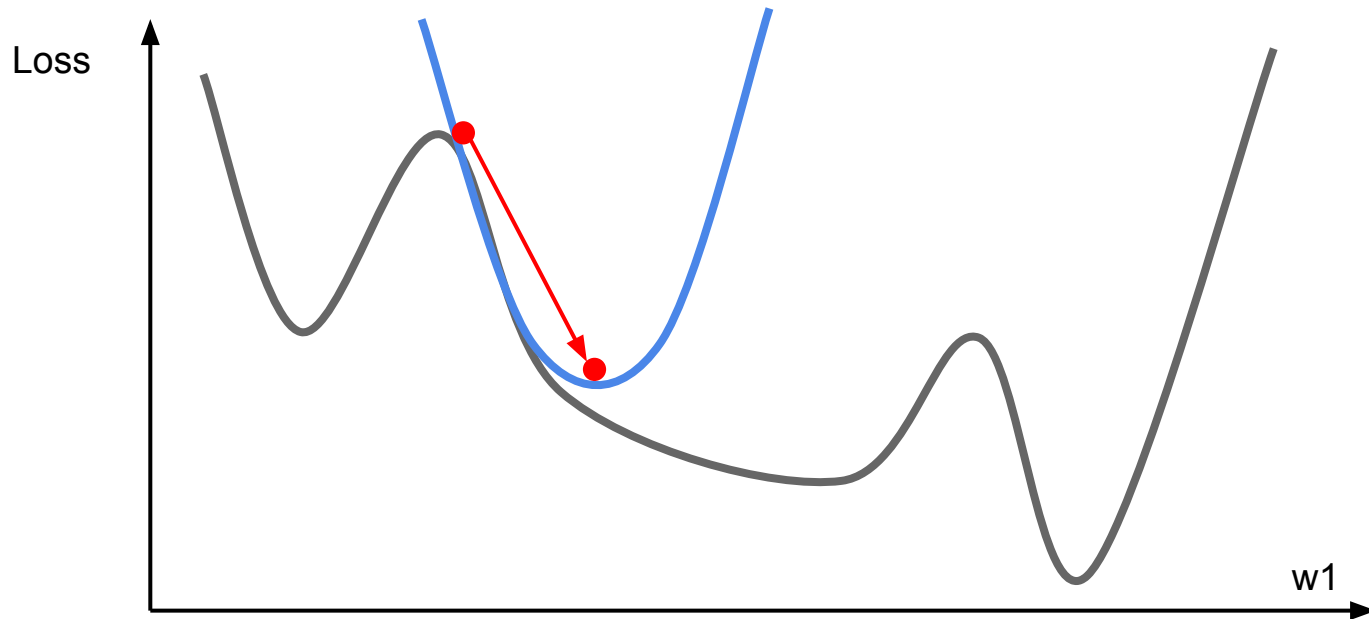

Second-Order Optimization

second-order Taylor expansion:

$$L(\theta) \approx L(\theta_0) + (\theta - \theta_0)^T \nabla_{\theta} L(\theta_0) + \frac{1}{2} (\theta - \theta_0)^T H (\theta - \theta_0)$$

Solving for the critical point we obtain the Newton parameter update:

$$\theta^* = \theta_0 - H^{-1} \nabla_{\theta} L(\theta_0)$$

Q: Why is this bad for deep learning?

Second-Order Optimization

second-order Taylor expansion:

$$L(\theta) \approx L(\theta_0) + (\theta - \theta_0)^T \nabla_{\theta} L(\theta_0) + \frac{1}{2} (\theta - \theta_0)^T H (\theta - \theta_0)$$

Solving for the critical point we obtain the Newton parameter update:

$$\theta^* = \theta_0 - H^{-1} \nabla_{\theta} L(\theta_0)$$

Hessian has $O(N^2)$ elements
Inverting takes $O(N^3)$
 $N =$ (Tens or Hundreds of) Millions

Q: Why is this bad for deep learning?

Second-Order Optimization

$$\theta^* = \theta_0 - H^{-1} \nabla_{\theta} L(\theta_0)$$

- Quasi-Newton methods (**BGFS** most popular):
instead of inverting the Hessian ($O(n^3)$), approximate inverse Hessian with rank 1 updates over time ($O(n^2)$ each).
- **L-BFGS** (Limited memory BFGS):
Does not form/store the full inverse Hessian.

L-BFGS

- **Usually works very well in full batch, deterministic mode** i.e. if you have a single, deterministic $f(x)$ then L-BFGS will probably work very nicely
- **Does not transfer very well to mini-batch setting.** Gives bad results. Adapting second-order methods to large-scale, stochastic setting is an active area of research.

Le et al, "On optimization methods for deep learning, ICML 2011"

Ba et al, "Distributed second-order optimization using Kronecker-factored approximations", ICLR 2017

In practice:

- **AdamW** should probably be your “default” optimizer for new problems
- **Adam** is a good second choice in many cases; it often works ok even with constant learning rate
- **SGD+Momentum** can outperform Adam but may require more tuning of LR and schedule
 - Try cosine schedule, very few hyperparameters!

Learning rate schedules

SGD, SGD+Momentum, Adagrad, RMSProp, Adam all have **learning rate** as a hyperparameter.

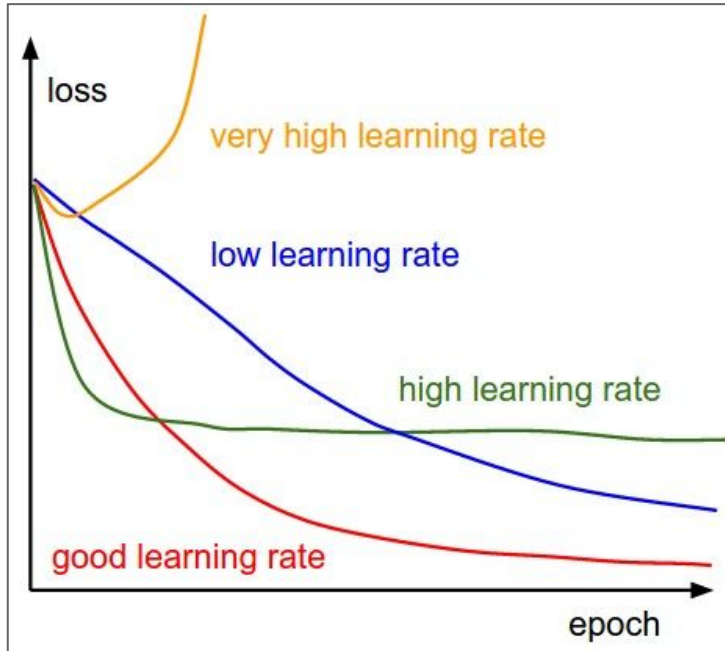

Q: Which one of these learning rates is best to use?

SGD, SGD+Momentum, Adagrad, RMSProp, Adam all have **learning rate** as a hyperparameter.

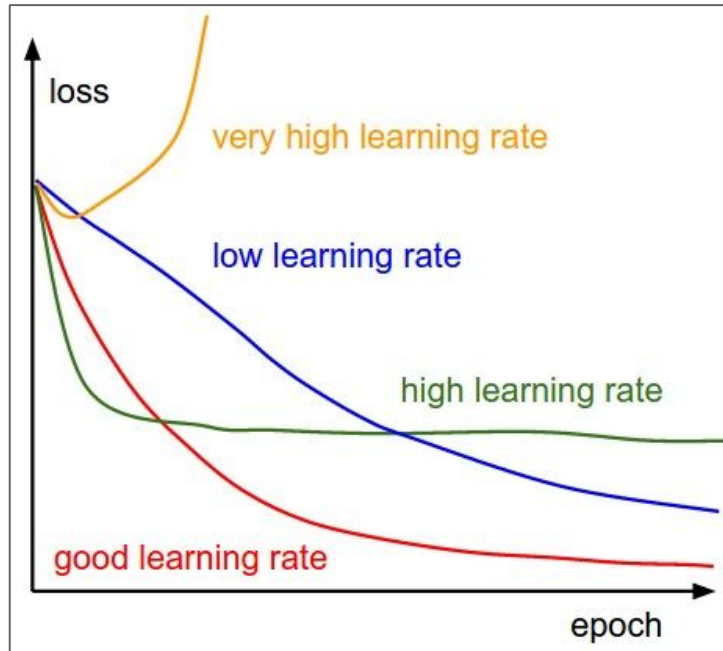

Q: Which one of these learning rates is best to use?

A: In reality, all of these are good learning rates.

Phases of learning...

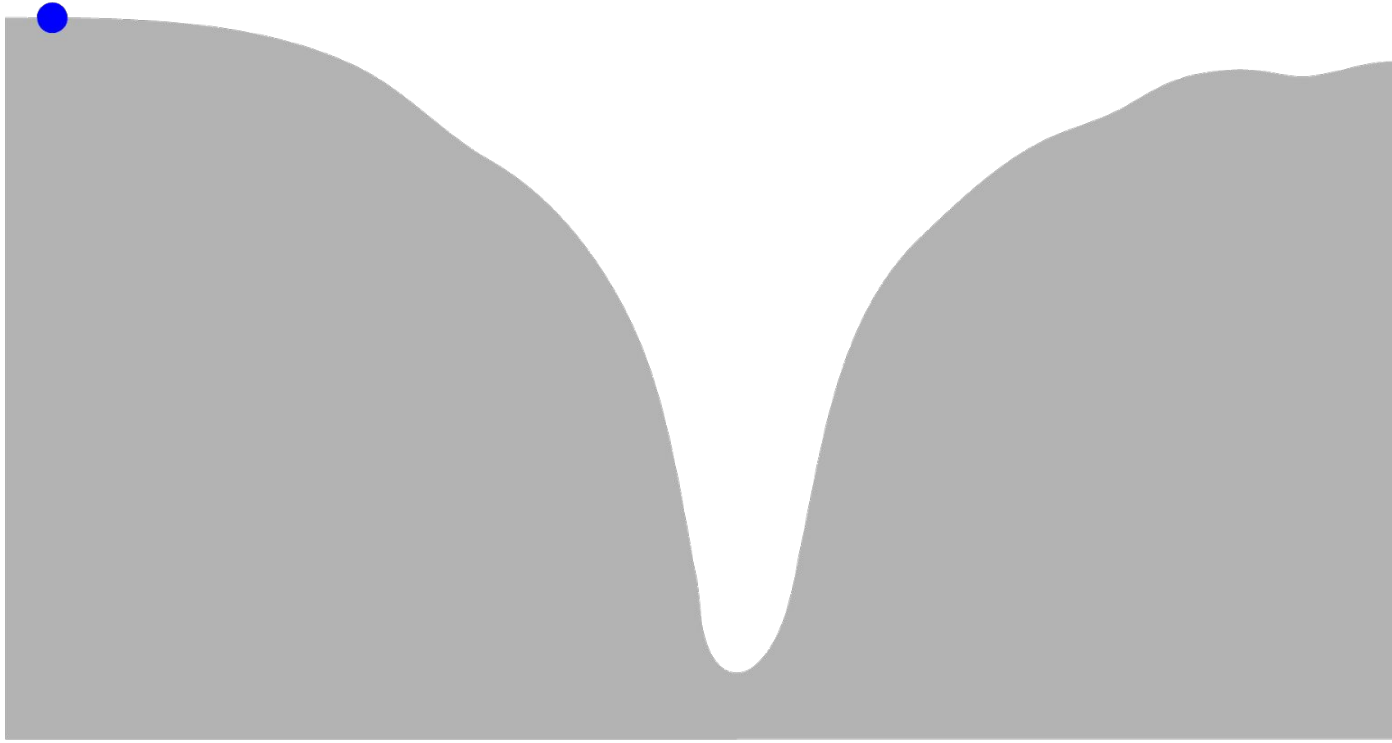

Phases of learning...

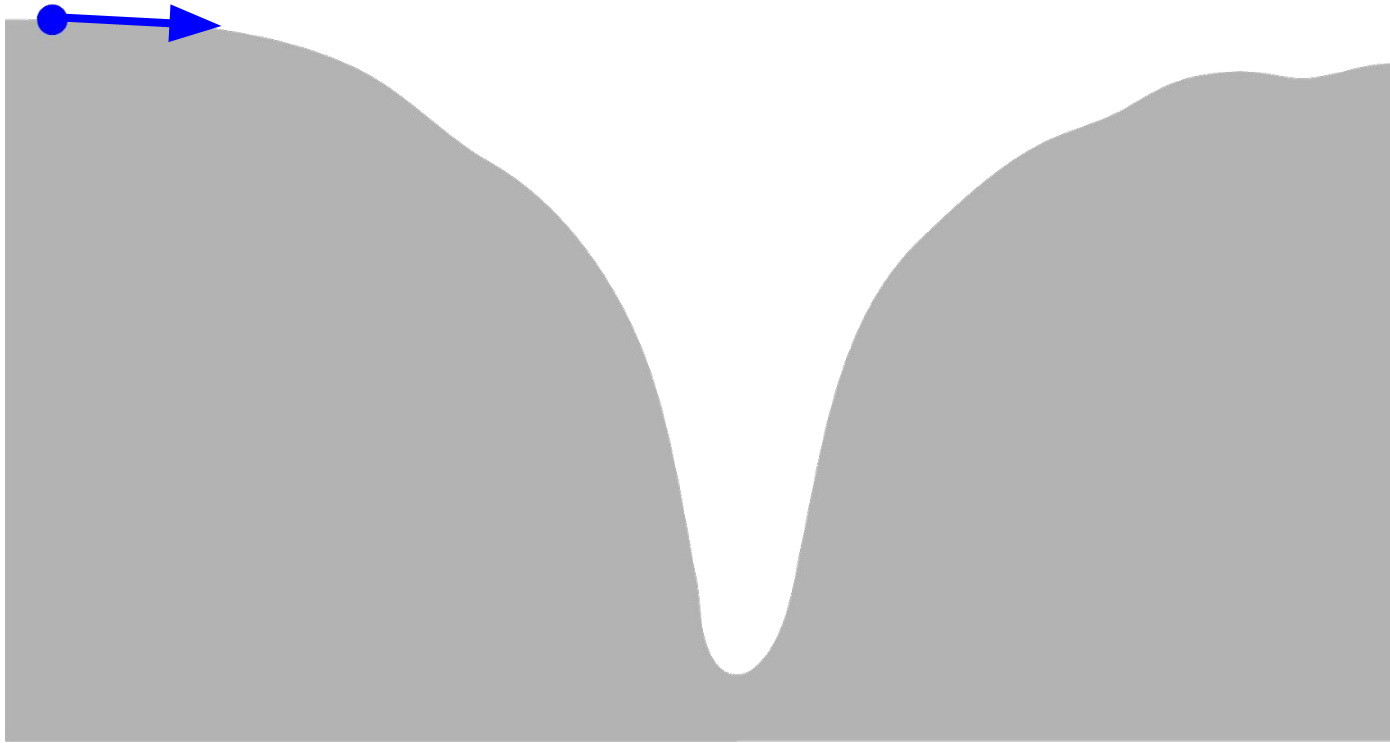

Phases of learning...

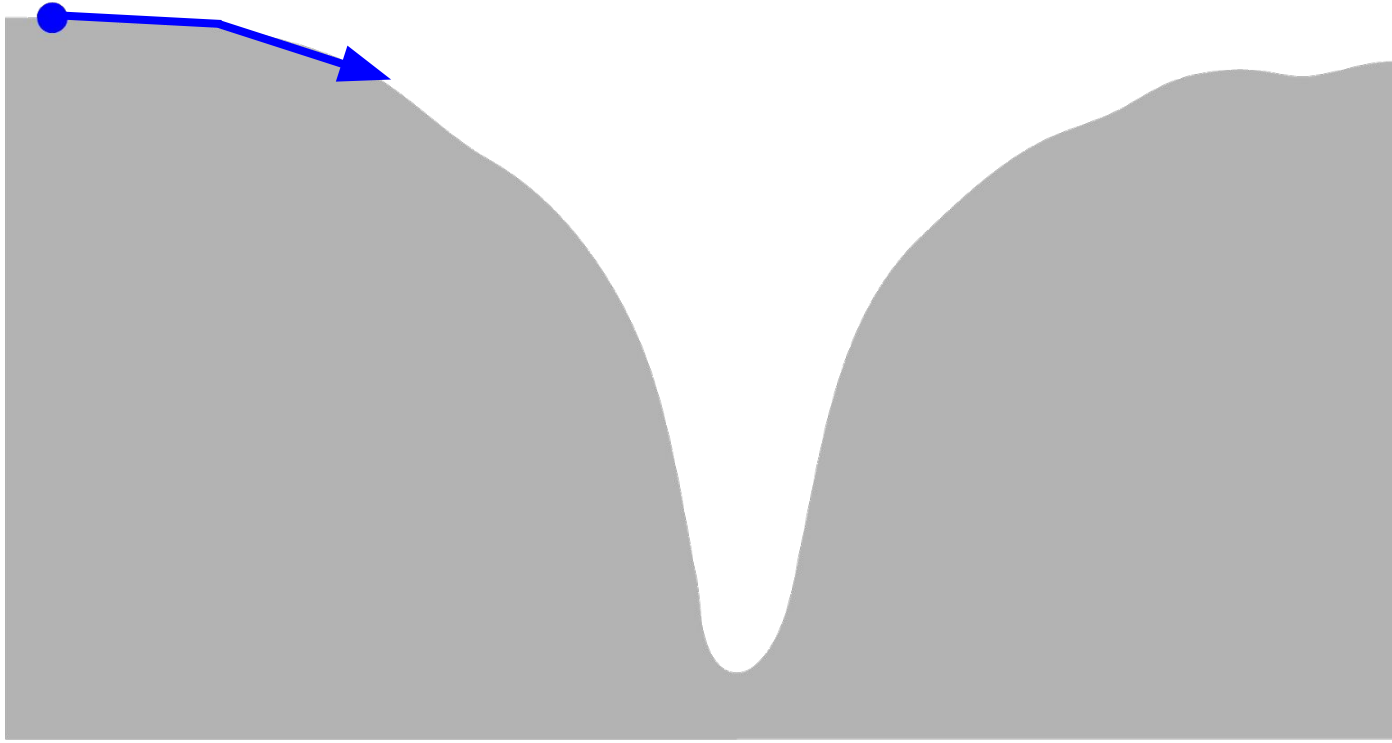

Phases of learning...

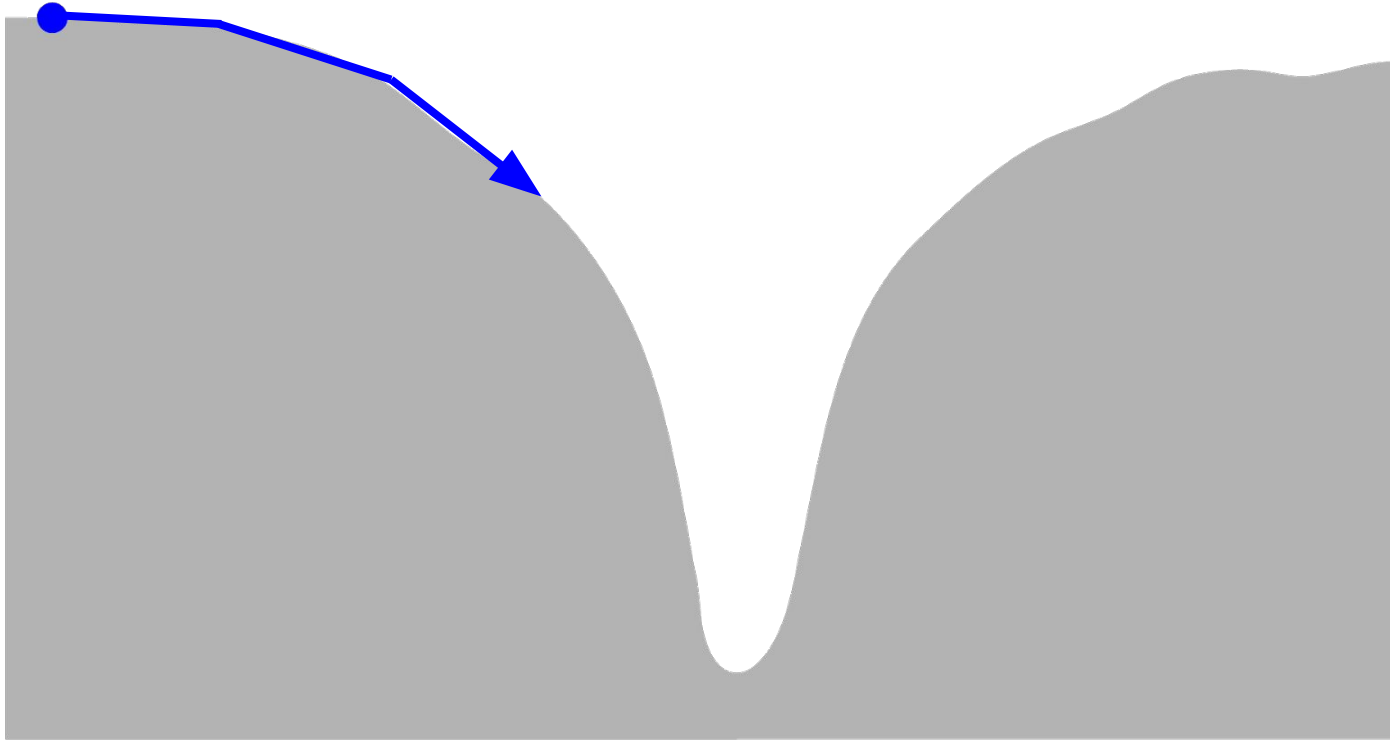

Phases of learning...

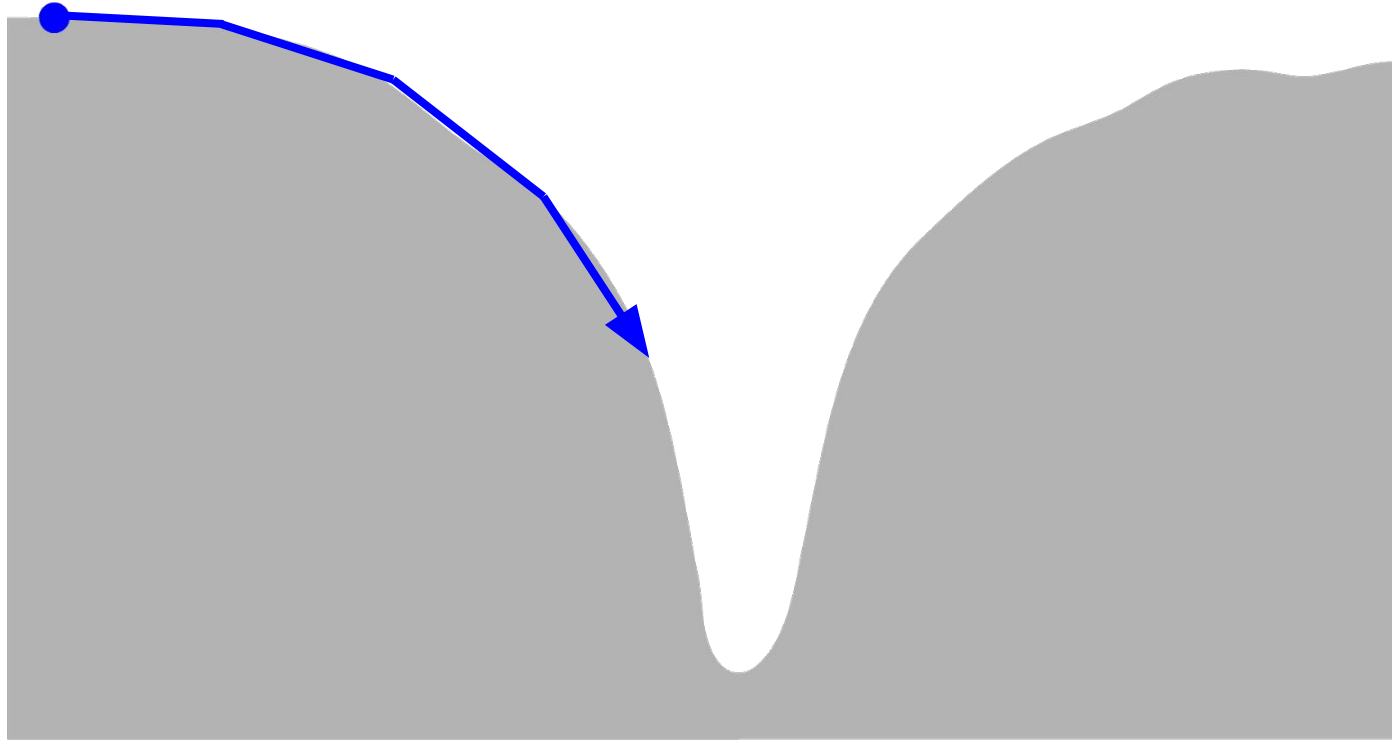

Phases of learning...

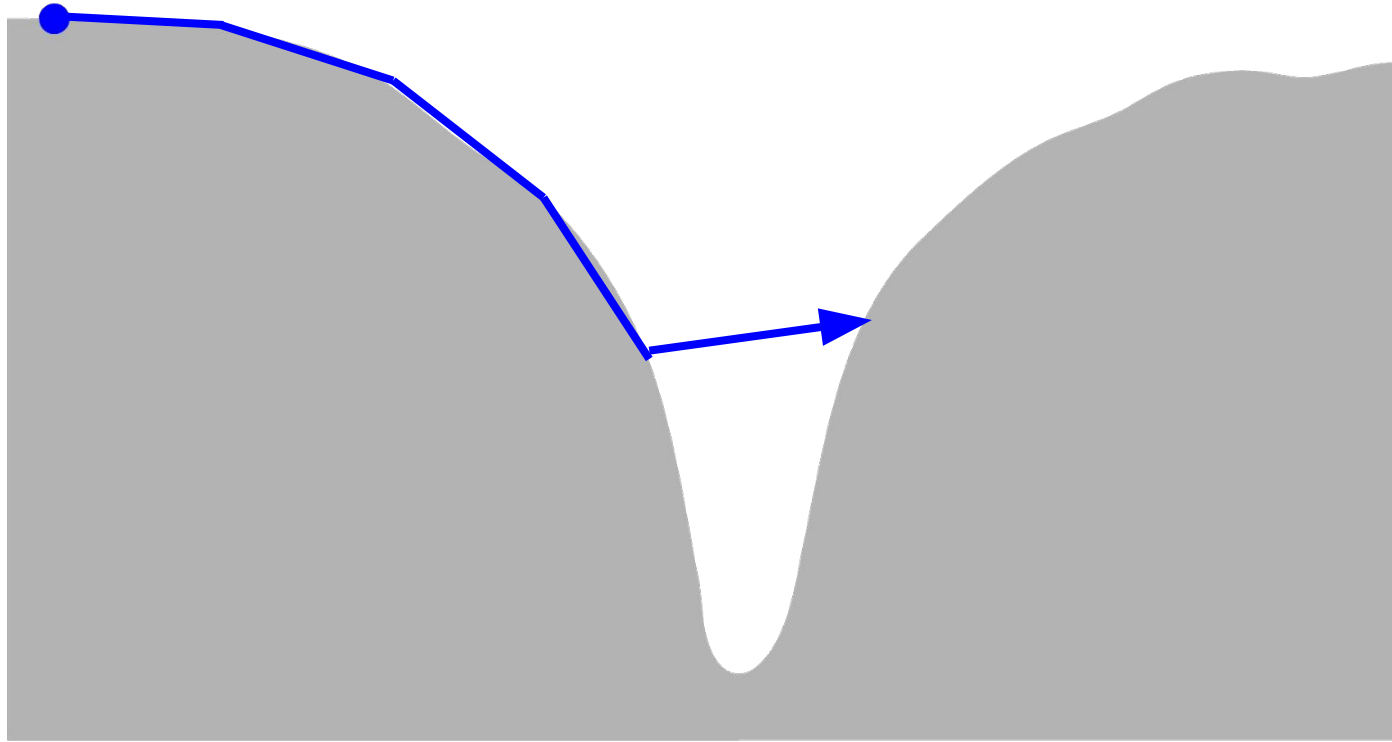

Phases of learning...

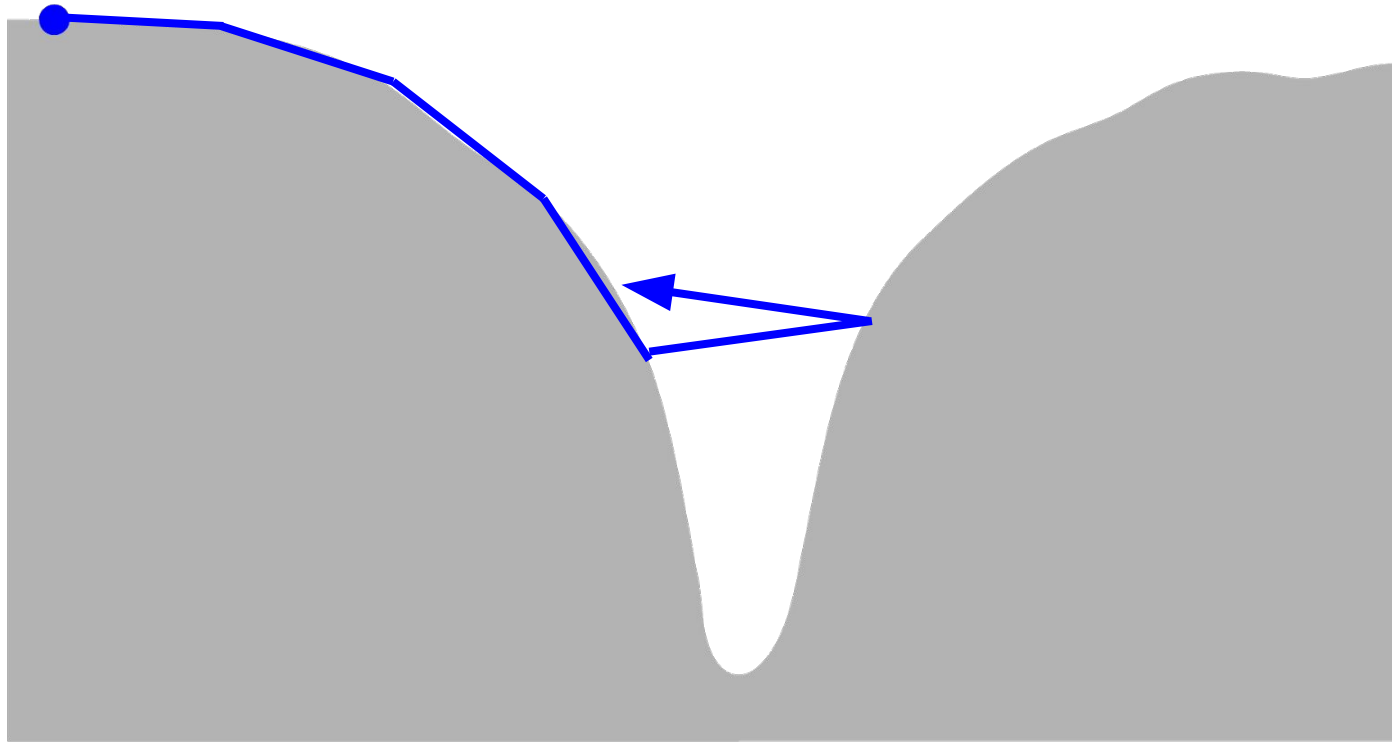

Phases of learning...

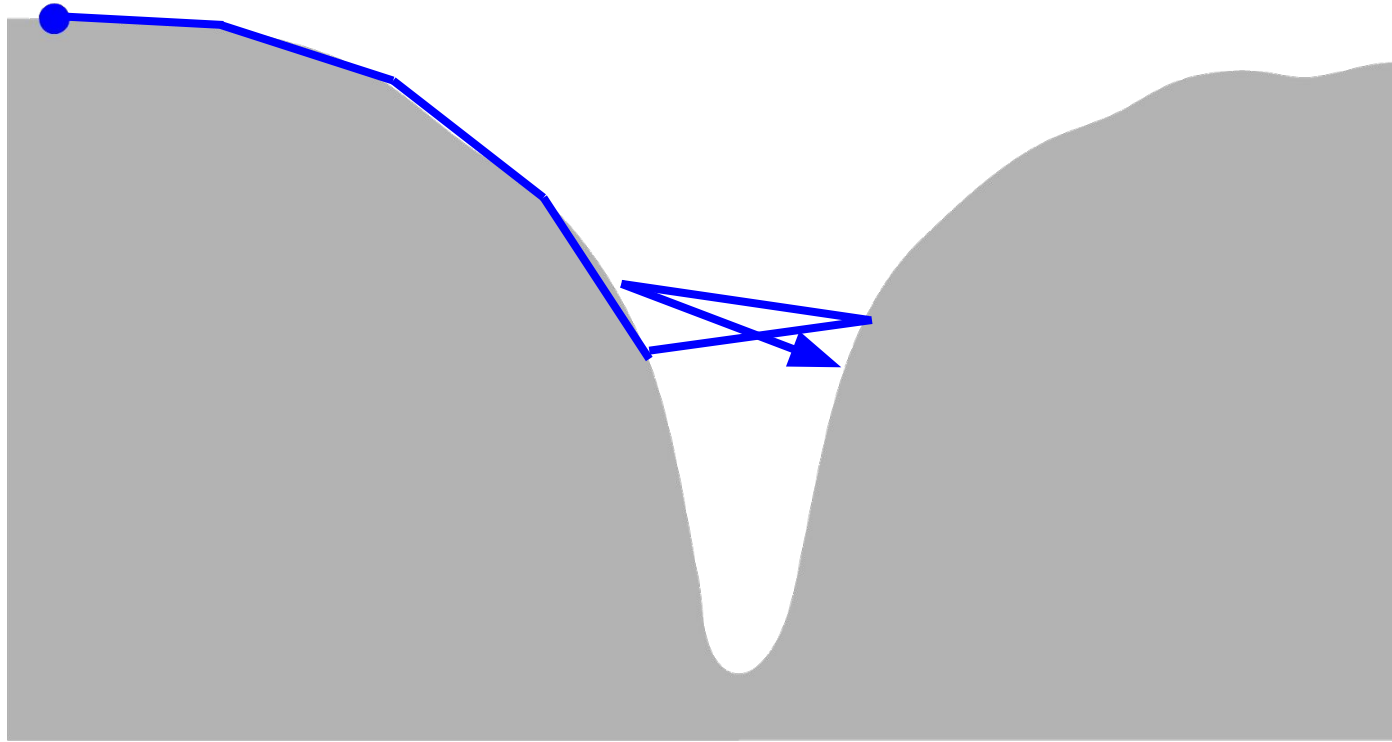

Phases of learning...

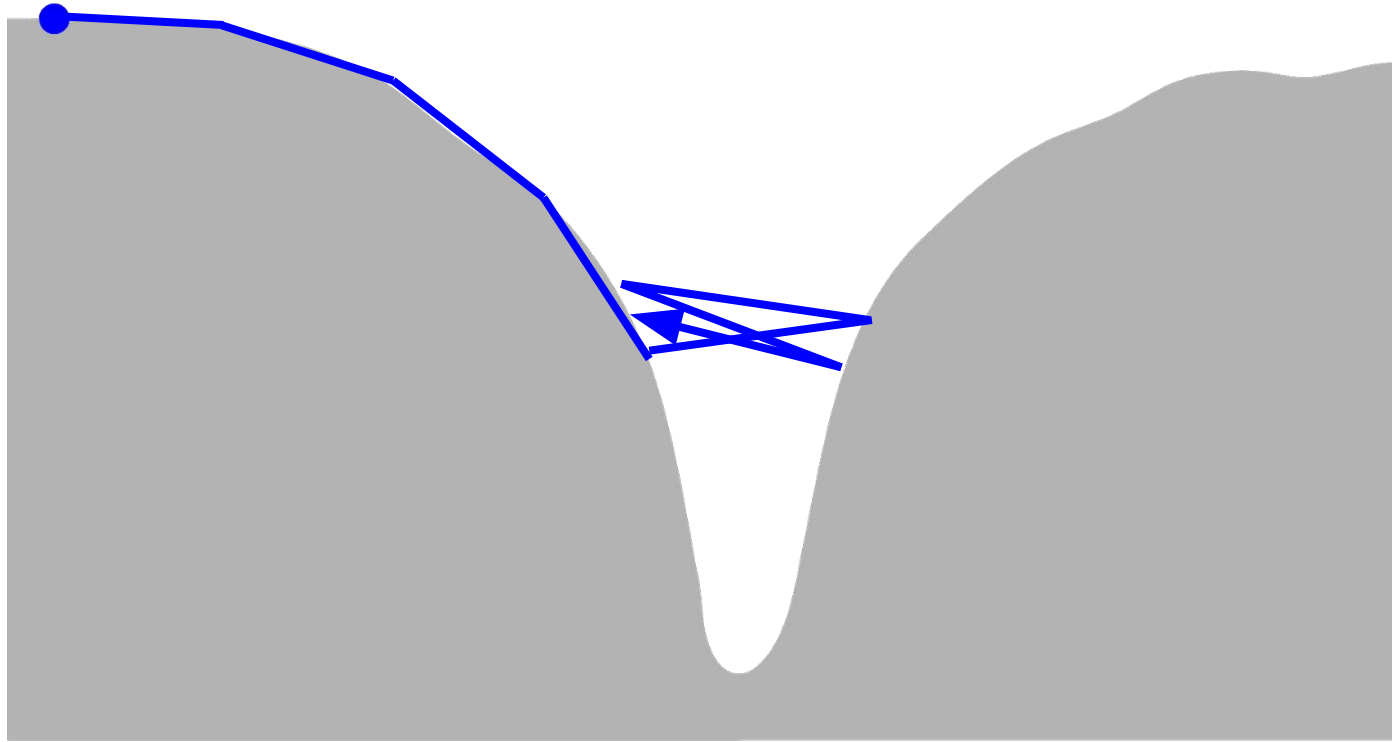

Learning rate decays over time

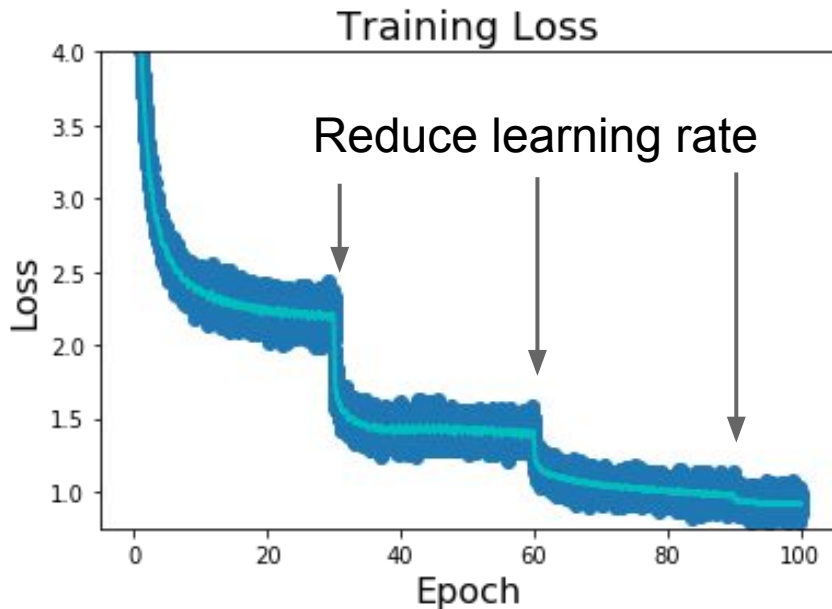

Step: Reduce learning rate at a few fixed points. E.g. for ResNets, multiply LR by 0.1 after epochs 30, 60, and 90.

Phases of learning...

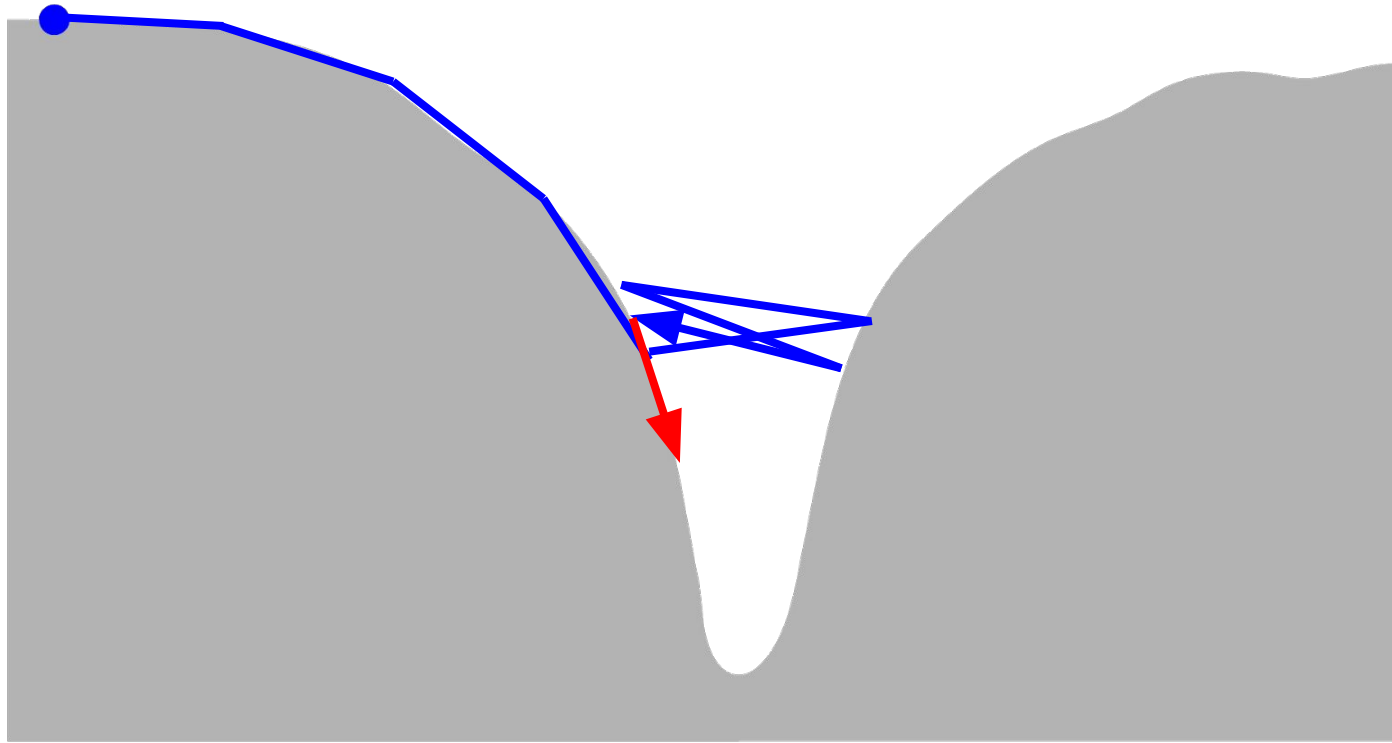

Phases of learning...

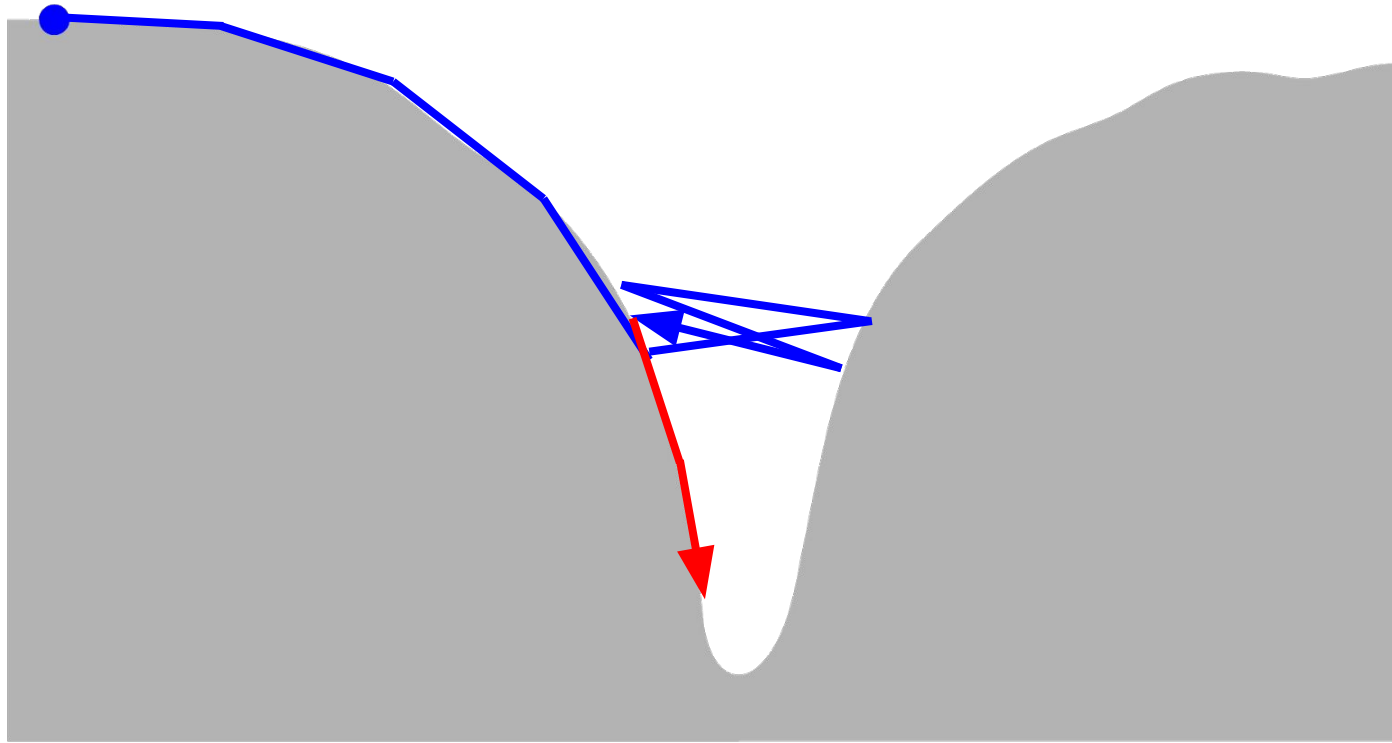

Learning Rate Decay

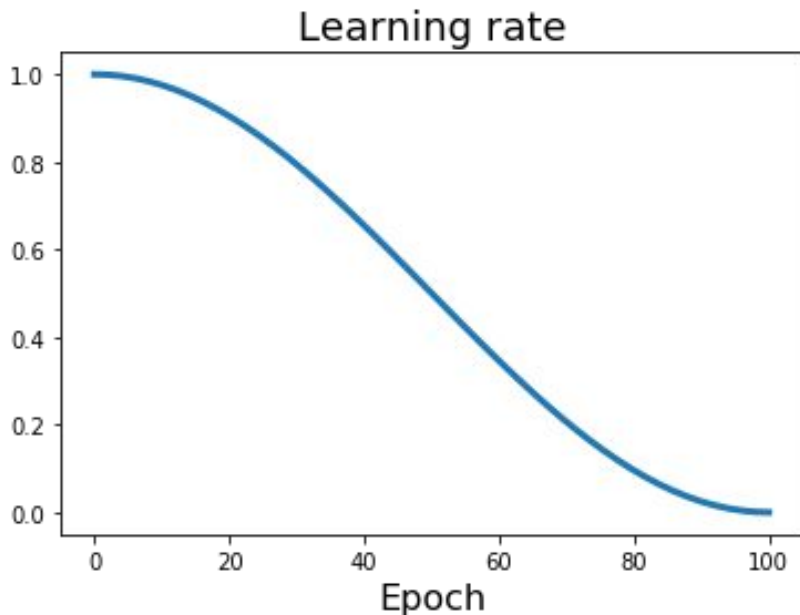

Step: Reduce learning rate at a few fixed points. E.g. for ResNets, multiply LR by 0.1 after epochs 30, 60, and 90.

Cosine: $\alpha_t = \frac{1}{2}\alpha_0 (1 + \cos(t\pi/T))$

α_0 : Initial learning rate
 α_t : Learning rate at epoch t
 T : Total number of epochs

Loshchilov and Hutter, “SGDR: Stochastic Gradient Descent with Warm Restarts”, ICLR 2017
Radford et al, “Improving Language Understanding by Generative Pre-Training”, 2018
Feichtenhofer et al, “SlowFast Networks for Video Recognition”, arXiv 2018
Child et al, “Generating Long Sequences with Sparse Transformers”, arXiv 2019

Learning Rate Decay

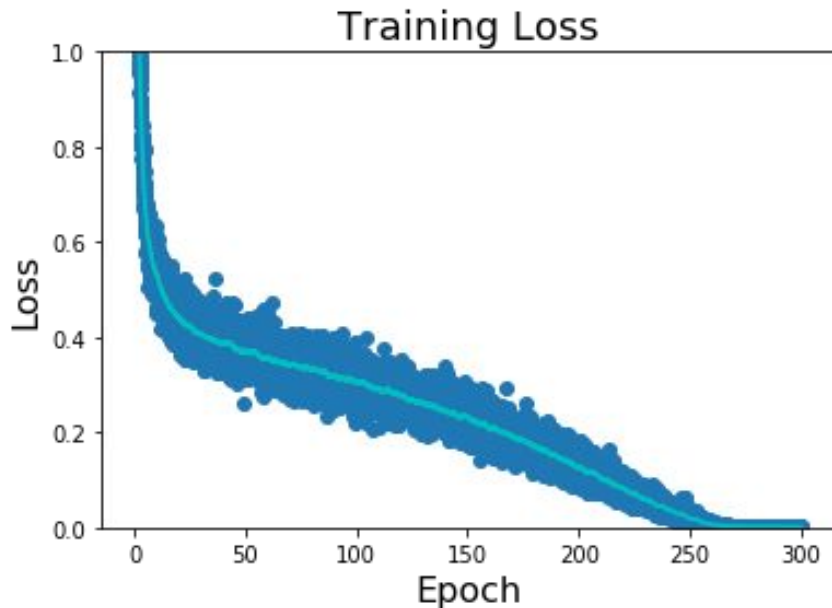

Step: Reduce learning rate at a few fixed points. E.g. for ResNets, multiply LR by 0.1 after epochs 30, 60, and 90.

Cosine: $\alpha_t = \frac{1}{2}\alpha_0 (1 + \cos(t\pi/T))$

α_0 : Initial learning rate

α_t : Learning rate at epoch t

T : Total number of epochs

Loshchilov and Hutter, "SGDR: Stochastic Gradient Descent with Warm Restarts", ICLR 2017
Radford et al, "Improving Language Understanding by Generative Pre-Training", 2018
Feichtenhofer et al, "SlowFast Networks for Video Recognition", arXiv 2018
Child et al, "Generating Long Sequences with Sparse Transformers", arXiv 2019

Learning Rate Decay

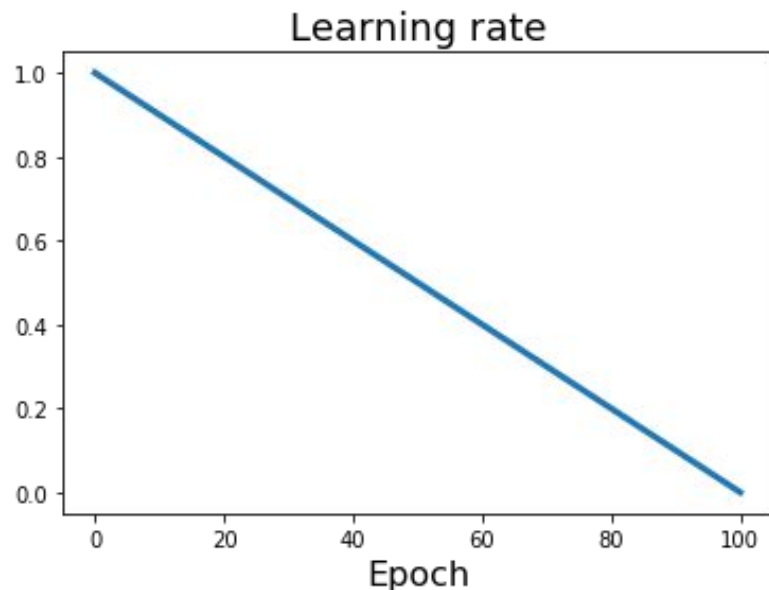

Step: Reduce learning rate at a few fixed points. E.g. for ResNets, multiply LR by 0.1 after epochs 30, 60, and 90.

Cosine: $\alpha_t = \frac{1}{2}\alpha_0 (1 + \cos(t\pi/T))$

Linear: $\alpha_t = \alpha_0(1 - t/T)$

α_0 : Initial learning rate

α_t : Learning rate at epoch t

T : Total number of epochs

Learning Rate Decay

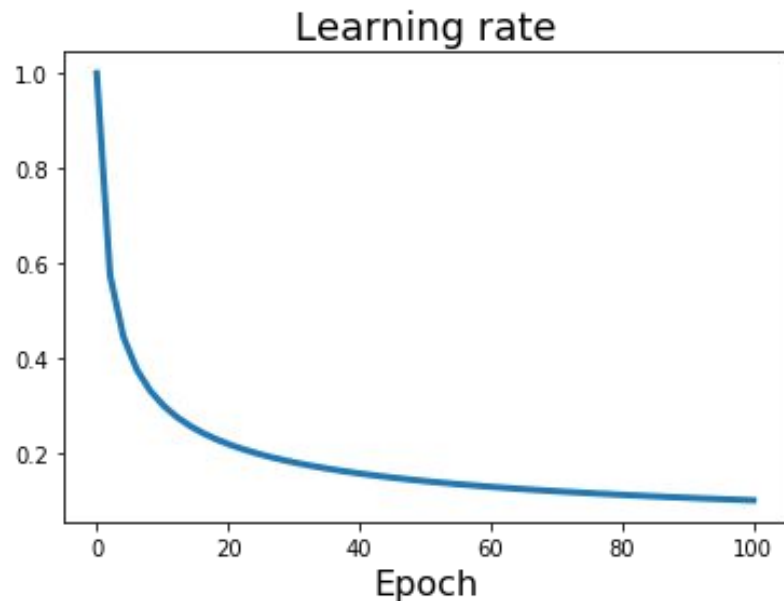

Step: Reduce learning rate at a few fixed points. E.g. for ResNets, multiply LR by 0.1 after epochs 30, 60, and 90.

Cosine: $\alpha_t = \frac{1}{2}\alpha_0 (1 + \cos(t\pi/T))$

Linear: $\alpha_t = \alpha_0(1 - t/T)$

Inverse sqrt: $\alpha_t = \alpha_0/\sqrt{t}$

α_0 : Initial learning rate

α_t : Learning rate at epoch t

T : Total number of epochs

Learning Rate Decay

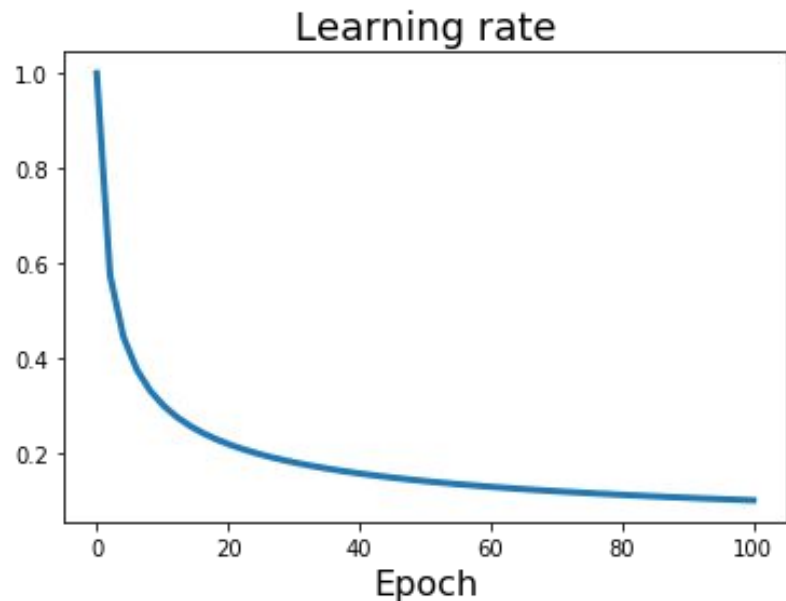

Step: Reduce learning rate at a few fixed points. E.g. for ResNets, multiply LR by 0.1 after epochs 30, 60, and 90.

Cosine: $\alpha_t = \frac{1}{2}\alpha_0 (1 + \cos(t\pi/T))$

Linear: $\alpha_t = \alpha_0(1 - t/T)$

Inverse sqrt: $\alpha_t = \alpha_0/\sqrt{t}$

Constant: $\alpha_t = \alpha_0$

Vaswani et al, "Attention is all you need", NIPS 2017

Learning Rate Decay: Linear Warmup

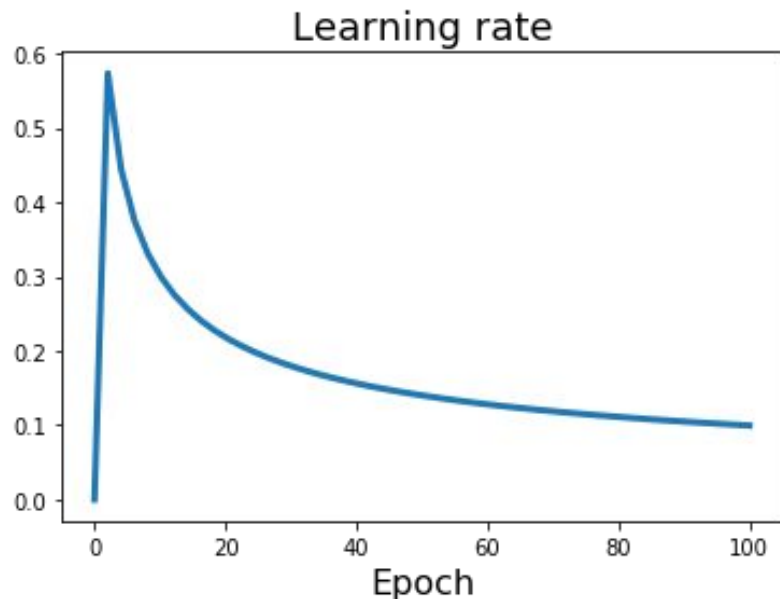

High initial learning rates can make loss explode; linearly increasing learning rate from 0 over the first ~5000 iterations can prevent this

Empirical rule of thumb: If you increase the batch size by N , also scale the initial learning rate by N

Goyal et al, "Accurate, Large Minibatch SGD: Training ImageNet in 1 Hour", arXiv 2017

with
cosine
and
warmup

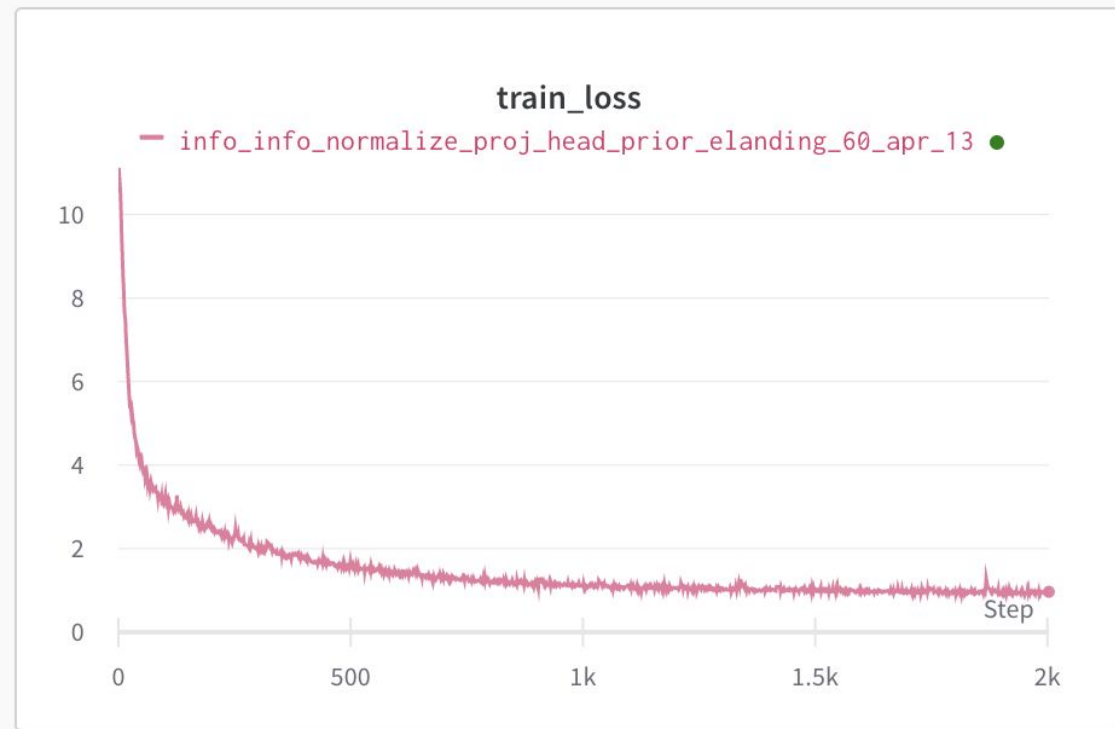

Improve test error

Beyond Training Error

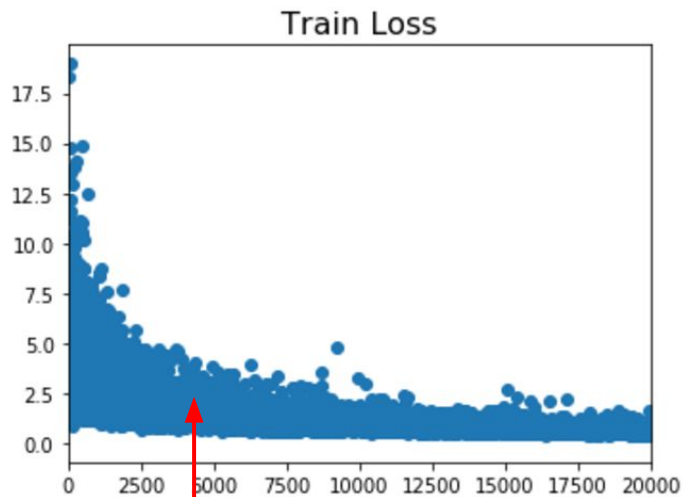

Better optimization algorithms help reduce training loss

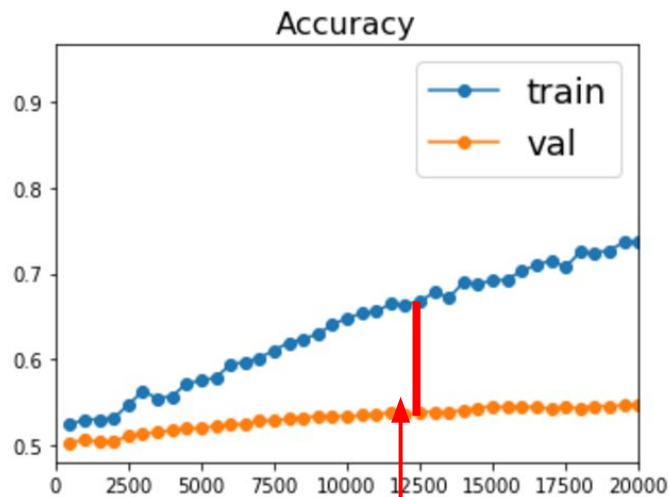

But we really care about error on new data - how to reduce the gap?

Early Stopping: Always do this

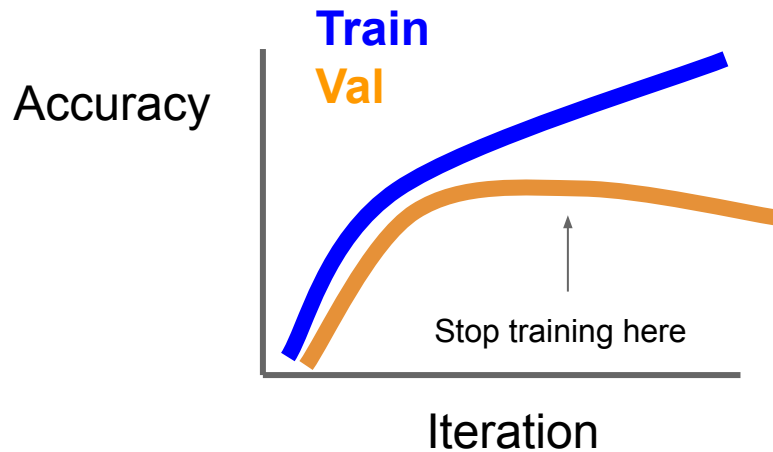
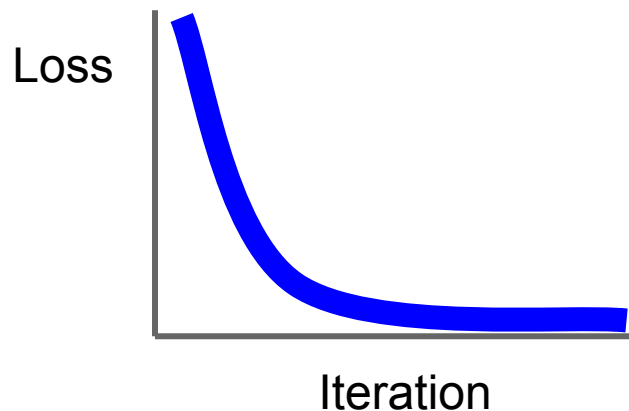

Stop training the model when accuracy on the validation set decreases
Or train for a long time, but always keep track of the model snapshot
that worked best on val

Model Ensembles

1. Train multiple independent models
2. At test time average their results
(Take average of predicted probability distributions, then choose argmax)

Enjoy 2% extra performance

How to improve single-model performance?

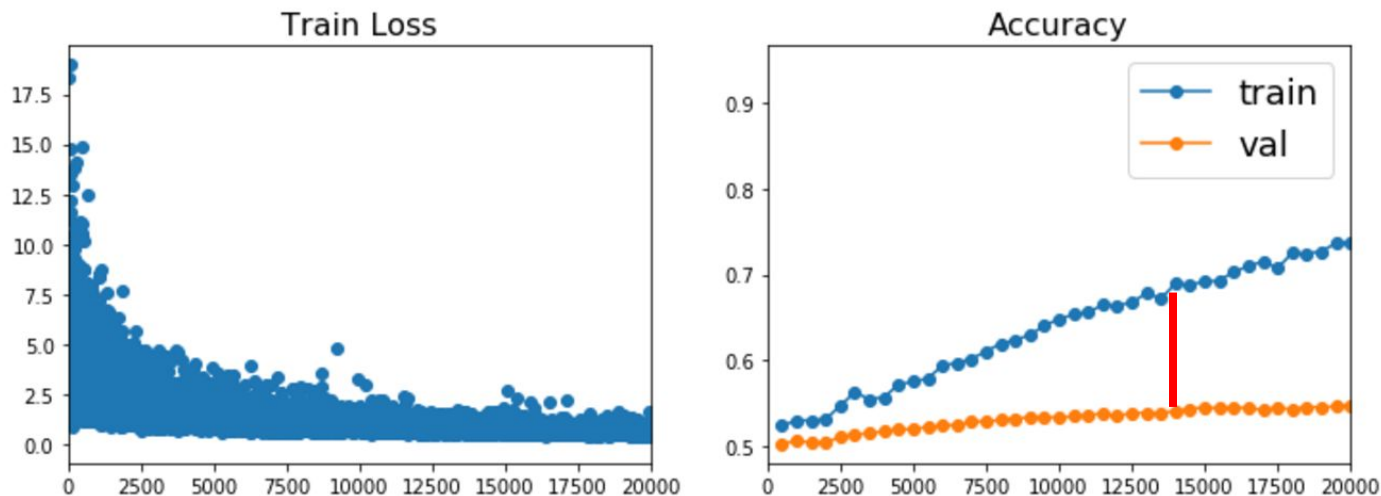

Regularization

Regularization: Add term to loss

$$L = \frac{1}{N} \sum_{i=1}^N \sum_{j \neq y_i} \max(0, f(x_i; W)_j - f(x_i; W)_{y_i} + 1) + \lambda R(W)$$

In common use:

L2 regularization

$$R(W) = \sum_k \sum_l W_{k,l}^2 \quad (\text{Weight decay})$$

L1 regularization

$$R(W) = \sum_k \sum_l |W_{k,l}|$$

Elastic net (L1 + L2)

$$R(W) = \sum_k \sum_l \beta W_{k,l}^2 + |W_{k,l}|$$

Regularization: Dropout

In each forward pass, randomly set some neurons to zero
Probability of dropping is a hyperparameter; 0.5 is common

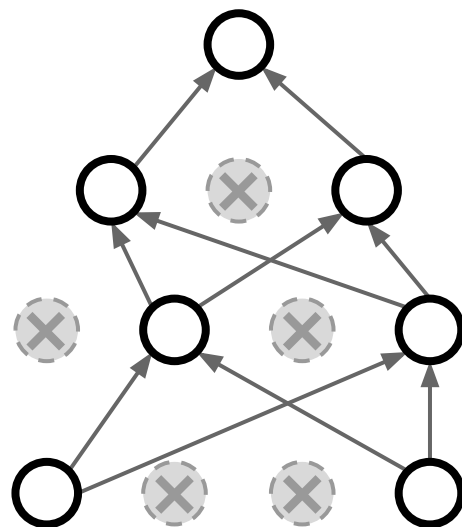
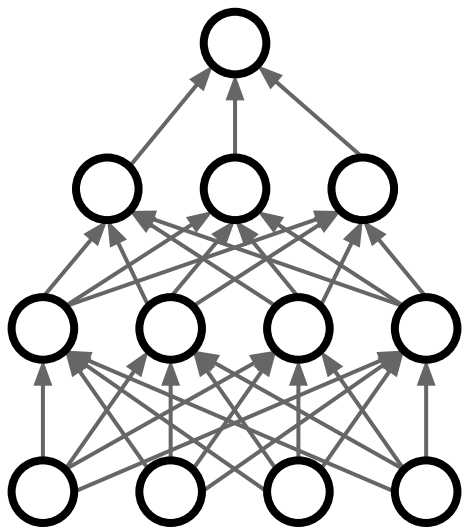

Srivastava et al, "Dropout: A simple way to prevent neural networks from overfitting", JMLR 2014

Regularization: Dropout

```
p = 0.5 # probability of keeping a unit active. higher = less dropout
```

```
def train_step(X):
```

```
    """ X contains the data """
```

```
    # forward pass for example 3-layer neural network
```

```
    H1 = np.maximum(0, np.dot(W1, X) + b1)
```

```
    U1 = np.random.rand(*H1.shape) < p # first dropout mask
```

```
    H1 *= U1 # drop!
```

```
    H2 = np.maximum(0, np.dot(W2, H1) + b2)
```

```
    U2 = np.random.rand(*H2.shape) < p # second dropout mask
```

```
    H2 *= U2 # drop!
```

```
    out = np.dot(W3, H2) + b3
```

```
    # backward pass: compute gradients... (not shown)
```

```
    # perform parameter update... (not shown)
```

Example forward pass with a 3-layer network using dropout

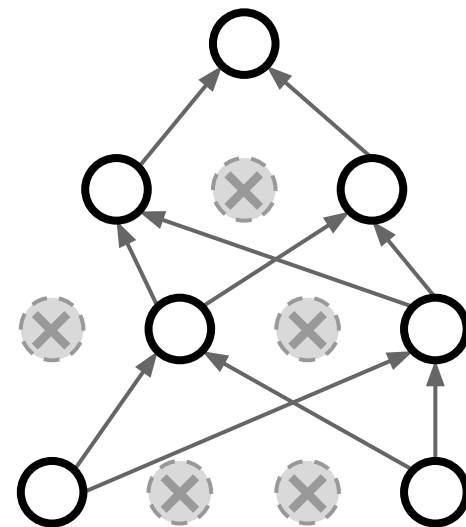

Regularization: Dropout

How can this possibly be a good idea?

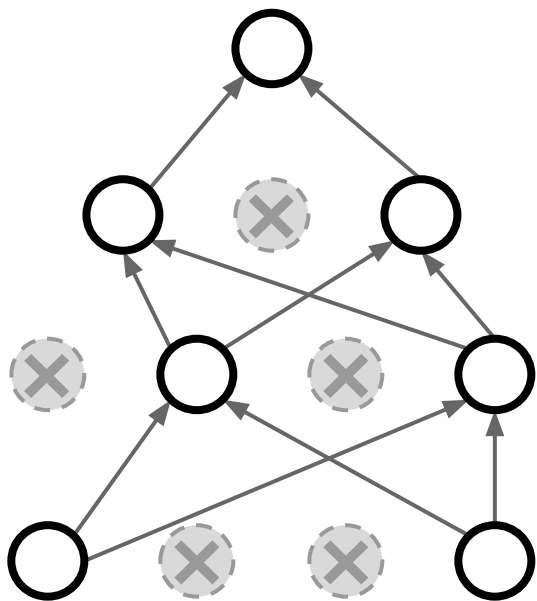

Forces the network to have a redundant representation;
Prevents co-adaptation of features



Regularization: Dropout

How can this possibly be a good idea?

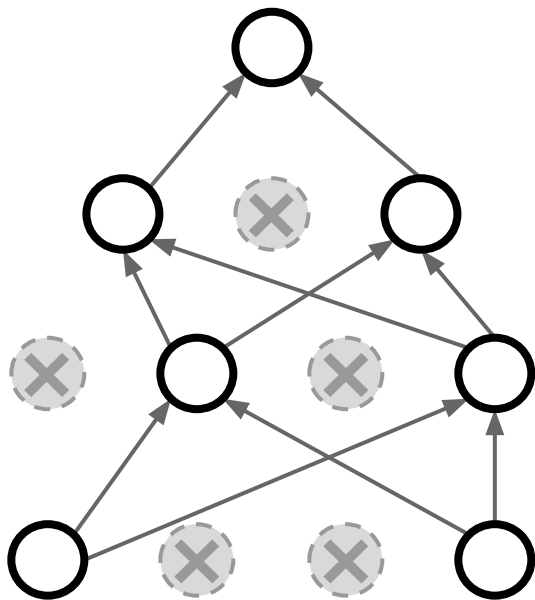

Another interpretation:

Dropout is training a large **ensemble** of models (that share parameters).

Each binary mask is one model

An FC layer with 4096 units has $2^{4096} \sim 10^{1233}$ possible masks!

Only $\sim 10^{82}$ atoms in the universe...

Dropout: Test time

Dropout makes our output random!

$$\begin{array}{l} \text{Output} \\ \text{(label)} \end{array} \quad \begin{array}{l} \text{Input} \\ \text{(image)} \end{array} \quad \begin{array}{l} \text{Random} \\ \text{mask} \end{array}$$
$$y = f_W(x, z)$$

The diagram shows the equation $y = f_W(x, z)$ with color-coded boxes: a red box around y , a blue box around x , and a green box around z . The labels "Output (label)", "Input (image)", and "Random mask" are positioned above their respective variables.

Want to “average out” the randomness at test-time

$$y = f(x) = E_z[f(x, z)] = \int p(z) f(x, z) dz$$

But this integral seems hard ...

Dropout: Test time

Want to approximate
the integral

$$y = f(x) = E_z [f(x, z)] = \int p(z) f(x, z) dz$$

Consider a single neuron.

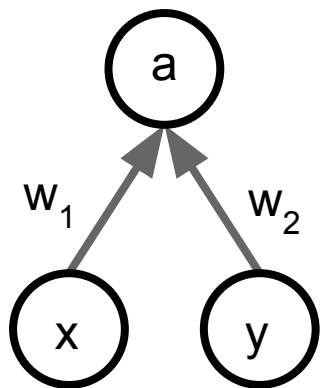

Dropout: Test time

Want to approximate the integral

$$y = f(x) = E_z [f(x, z)] = \int p(z) f(x, z) dz$$

Consider a single neuron.

At test time we have: $E[a] = w_1 x + w_2 y$

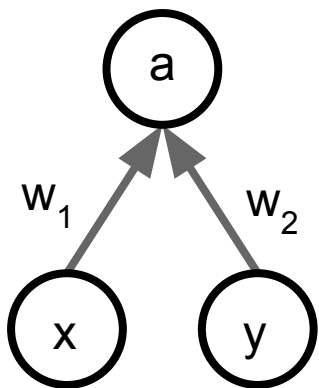

Dropout: Test time

Want to approximate the integral

$$y = f(x) = E_z [f(x, z)] = \int p(z) f(x, z) dz$$

Consider a single neuron.

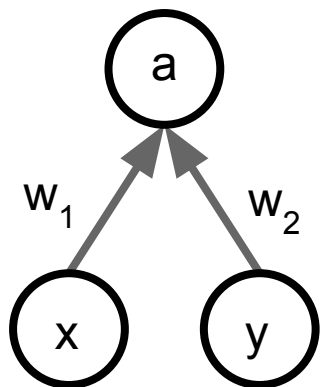

At test time we have: $E[a] = w_1x + w_2y$

During training we have: $E[a] = \frac{1}{4}(w_1x + w_2y) + \frac{1}{4}(w_1x + w_20) + \frac{1}{4}(w_10 + w_20) + \frac{1}{4}(w_10 + w_2y)$
 $= \frac{1}{2}(w_1x + w_2y)$

Dropout: Test time

Want to approximate the integral

$$y = f(x) = E_z [f(x, z)] = \int p(z) f(x, z) dz$$

Consider a single neuron.

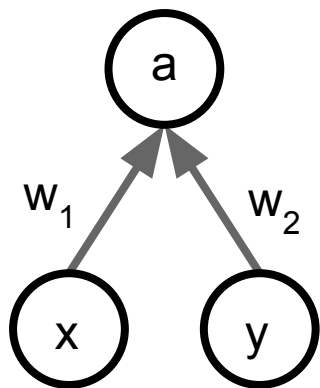

At test time we have: $E[a] = w_1x + w_2y$

During training we have: $E[a] = \frac{1}{4}(w_1x + w_2y) + \frac{1}{4}(w_1x + w_20)$

$$+ \frac{1}{4}(w_10 + w_20) + \frac{1}{4}(w_10 + w_2y)$$

**At test time, multiply
by dropout probability**

$$= \frac{1}{2}(w_1x + w_2y)$$

Dropout: Test time

```
def predict(X):  
    # ensembled forward pass  
    H1 = np.maximum(0, np.dot(W1, X) + b1) * p # NOTE: scale the activations  
    H2 = np.maximum(0, np.dot(W2, H1) + b2) * p # NOTE: scale the activations  
    out = np.dot(W3, H2) + b3
```

At test time all neurons are active always

=> We must scale the activations so that for each neuron:

output at test time = expected output at training time

Dropout Summary

```
""" Vanilla Dropout: Not recommended implementation (see notes below) """
```

```
p = 0.5 # probability of keeping a unit active. higher = less dropout
```

```
def train_step(X):
```

```
    """ X contains the data """
```

```
    # forward pass for example 3-layer neural network:
```

```
    H1 = np.maximum(0, np.dot(W1, X) + b1)
```

```
    U1 = np.random.rand(*H1.shape) < p # first dropout mask
```

```
    H1 *= U1 # drop!
```

```
    H2 = np.maximum(0, np.dot(W2, H1) + b2)
```

```
    U2 = np.random.rand(*H2.shape) < p # second dropout mask
```

```
    H2 *= U2 # drop!
```

```
    out = np.dot(W3, H2) + b3
```

```
    # backward pass: compute gradients... (not shown)
```

```
    # perform parameter update... (not shown)
```

```
def predict(X):
```

```
    # ensembled forward pass
```

```
    H1 = np.maximum(0, np.dot(W1, X) + b1) * p # NOTE: scale the activations
```

```
    H2 = np.maximum(0, np.dot(W2, H1) + b2) * p # NOTE: scale the activations
```

```
    out = np.dot(W3, H2) + b3
```

drop in train time

scale at test time

More common: “Inverted dropout”

```
p = 0.5 # probability of keeping a unit active. higher = less dropout

def train_step(X):
    # forward pass for example 3-layer neural network
    H1 = np.maximum(0, np.dot(W1, X) + b1)
    U1 = (np.random.rand(*H1.shape) < p) / p # first dropout mask. Notice /p!
    H1 *= U1 # drop!
    H2 = np.maximum(0, np.dot(W2, H1) + b2)
    U2 = (np.random.rand(*H2.shape) < p) / p # second dropout mask. Notice /p!
    H2 *= U2 # drop!
    out = np.dot(W3, H2) + b3

    # backward pass: compute gradients... (not shown)
    # perform parameter update... (not shown)

def predict(X):
    # ensembled forward pass
    H1 = np.maximum(0, np.dot(W1, X) + b1) # no scaling necessary
    H2 = np.maximum(0, np.dot(W2, H1) + b2)
    out = np.dot(W3, H2) + b3
```

test time is unchanged!



Regularization: A common pattern

Training: Add some kind of randomness

$$y = f_W(x, z)$$

Testing: Average out randomness (sometimes approximate)

$$y = f(x) = E_z[f(x, z)] = \int p(z)f(x, z)dz$$

Regularization: A common pattern

Training: Add some kind of randomness

$$y = f_W(x, z)$$

Testing: Average out randomness (sometimes approximate)

$$y = f(x) = E_z[f(x, z)] = \int p(z)f(x, z)dz$$

Example: Batch Normalization

Training: Normalize using stats from random minibatches

Testing: Use fixed stats to normalize

Regularization: Data Augmentation

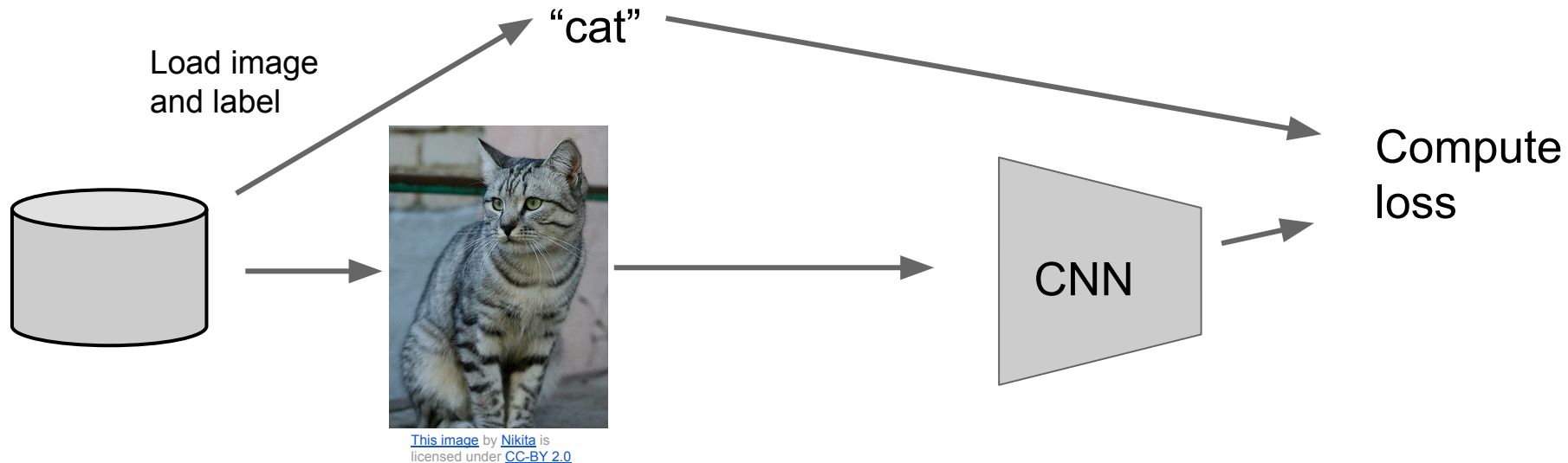

Regularization: Data Augmentation

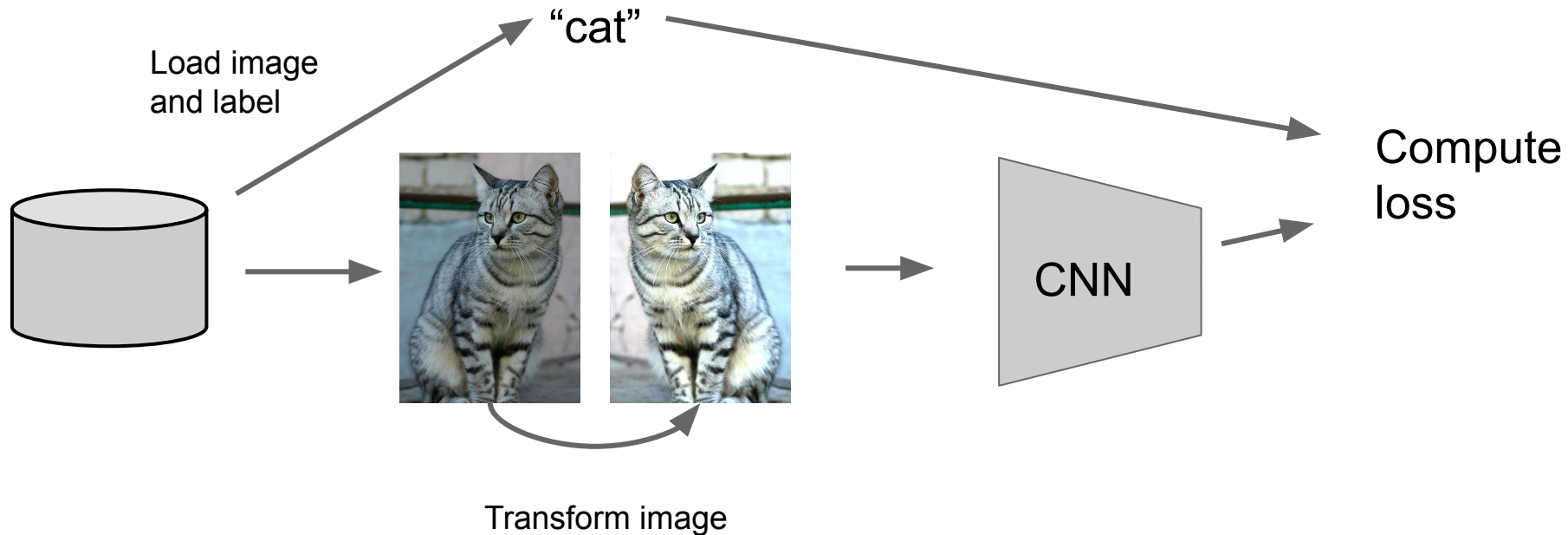

Data Augmentation

Horizontal Flips



Data Augmentation

Random crops and scales

Training: sample random crops / scales

ResNet:

1. Pick random L in range $[256, 480]$
2. Resize training image, short side = L
3. Sample random 224×224 patch

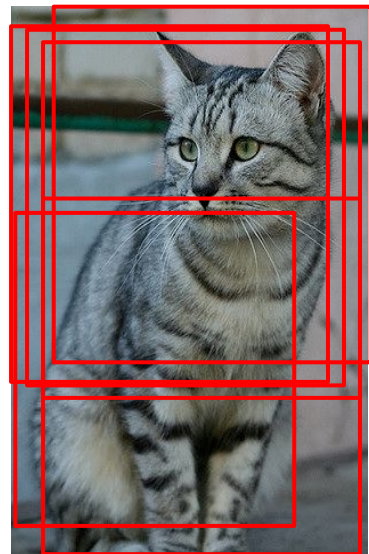

Data Augmentation

Random crops and scales

Training: sample random crops / scales

ResNet:

1. Pick random L in range $[256, 480]$
2. Resize training image, short side = L
3. Sample random 224×224 patch

Testing: average a fixed set of crops

ResNet:

1. Resize image at 5 scales: $\{224, 256, 384, 480, 640\}$
2. For each size, use 10 224×224 crops: 4 corners + center, + flips

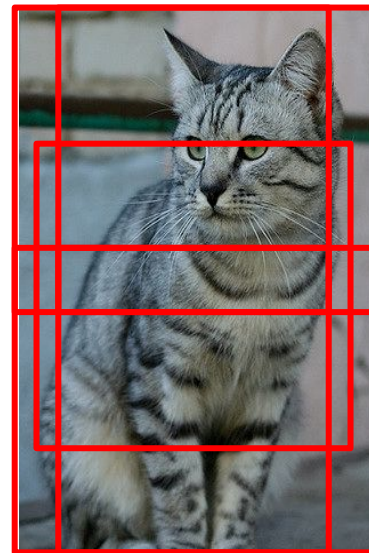

Data Augmentation

Color Jitter

Simple: Randomize
contrast and brightness



Data Augmentation

Color Jitter

Simple: Randomize
contrast and brightness



More Complex:

1. Apply PCA to all [R, G, B] pixels in training set
2. Sample a “color offset” along principal component directions
1. Add offset to all pixels of a training image

(As seen in [Krizhevsky et al. 2012], ResNet, etc)

Data Augmentation

Get creative for your problem!

Examples of data augmentations:

- translation
- rotation
- stretching
- shearing,
- lens distortions, ... (go crazy)

Automatic Data Augmentation

	Original	Sub-policy 1	Sub-policy 2	Sub-policy 3	Sub-policy 4	Sub-policy 5
Batch 1						
Batch 2						
Batch 3						
		ShearX, 0.9, 7 Invert, 0.2, 3	ShearY, 0.7, 6 Solarize, 0.4, 8	ShearX, 0.9, 4 AutoContrast, 0.8, 3	Invert, 0.9, 3 Equalize, 0.6, 3	ShearY, 0.8, 5 AutoContrast, 0.7, 3

Cubuk et al., "AutoAugment: Learning Augmentation Strategies from Data", CVPR 2019

Regularization: A common pattern

Training: Add random noise

Testing: Marginalize over the noise

Examples:

Dropout

Batch Normalization

Data Augmentation

Regularization: DropConnect

Training: Drop connections between neurons (set weights to 0)

Testing: Use all the connections

Examples:

Dropout

Batch Normalization

Data Augmentation

DropConnect

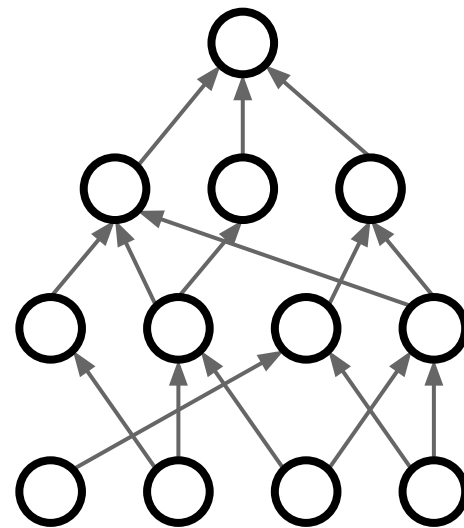
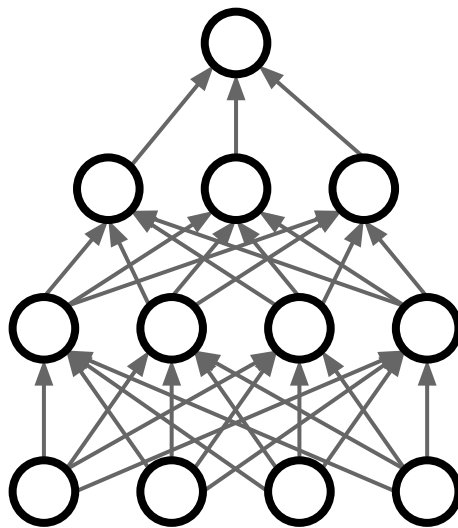

Wan et al, "Regularization of Neural Networks using DropConnect", ICML 2013

Regularization: Fractional Pooling

Training: Use randomized pooling regions

Testing: Average predictions from several regions

Examples:

Dropout

Batch Normalization

Data Augmentation

DropConnect

Fractional Max Pooling

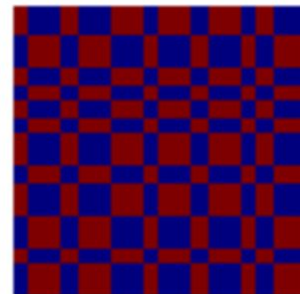
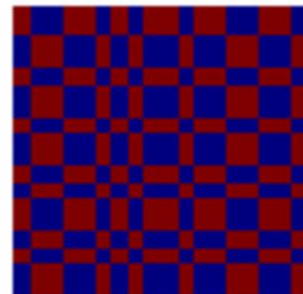
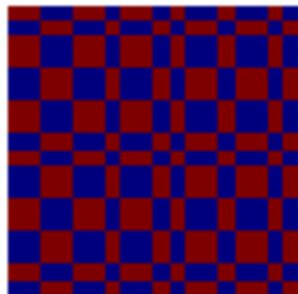

Regularization: Stochastic Depth

Training: Skip some layers in the network

Testing: Use all the layer

Examples:

Dropout

Batch Normalization

Data Augmentation

DropConnect

Fractional Max Pooling

Stochastic Depth (will become more clear in next week's lecture)

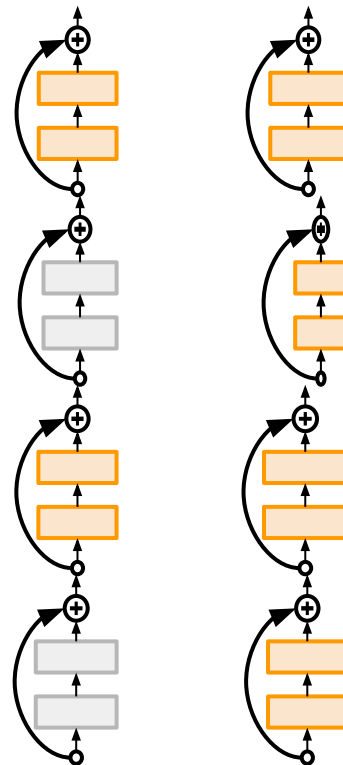

Huang et al, "Deep Networks with Stochastic Depth", ECCV 2016

Regularization: Cutout

Training: Set random image regions to zero

Testing: Use full image

Examples:

Dropout

Batch Normalization

Data Augmentation

DropConnect

Fractional Max Pooling

Stochastic Depth

Cutout / Random Crop

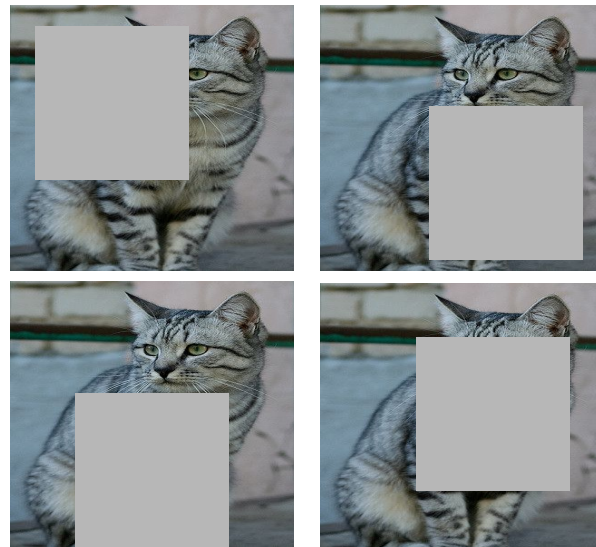

Works very well for small datasets like CIFAR,
less common for large datasets like ImageNet

DeVries and Taylor, "Improved Regularization of Convolutional Neural Networks with Cutout", arXiv 2017

Regularization: Mixup

Training: Train on random blends of images

Testing: Use original images

Examples:

Dropout

Batch Normalization

Data Augmentation

DropConnect

Fractional Max Pooling

Stochastic Depth

Cutout / Random Crop

Mixup

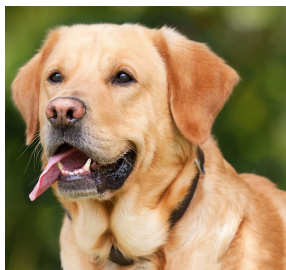

Randomly blend the pixels of pairs of training images, e.g. 40% cat, 60% dog

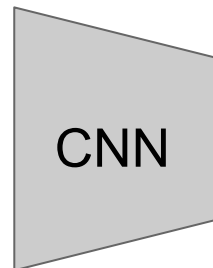

Target label:
cat: 0.4
dog: 0.6

Zhang et al, "mixup: Beyond Empirical Risk Minimization", ICLR 2018

Regularization: CutMix

Training: Train on random blends of images

Testing: Use original images

Examples:

Dropout

Batch Normalization

Data Augmentation

DropConnect

Fractional Max Pooling

Stochastic Depth

Cutout / Random Crop

Mixup

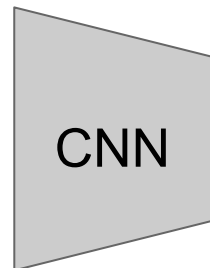
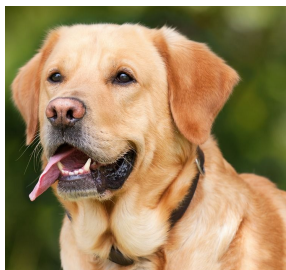

Target label:
cat: 0.4
dog: 0.6

Replace random crops of one image with another:
e.g. 60% of pixels from cat, 40% from dog

Yun et al, "CutMix: Regularization Strategies to Train Strong Classifiers with Localizable Features", ICCV 2019

Regularization: Label Smoothing

Training: Change target distribution

Testing: Take argmax over predictions

Examples:

Dropout

Batch Normalization

Data Augmentation

DropConnect

Fractional Max Pooling

Stochastic Depth

Cutout / Random Crop

Mixup

Label Smoothing



Standard Training:

Cat: 100%

Dog: 0%

Fish: 0%

Label Smoothing:

Cat: 90%

Dog: 5%

Fish: 5%

Set target distribution to be $1 - \frac{K-1}{K}\epsilon$ on the correct category and ϵ/K on all other categories, with K categories and $\epsilon \in [0, 1]$. Loss is cross-entropy between predicted and target distribution.

Szegedy et al, "Rethinking the Inception Architecture for Computer Vision", CVPR 2015

Regularization - In practice

Training: Add random noise

Testing: Marginalize over the noise

Examples:

Dropout

Batch Normalization

Data Augmentation

DropConnect

Fractional Max Pooling

Stochastic Depth

Cutout / Random Crop

Mixup

- Use **dropout** for large fully-connected layers
- Using **batchnorm** is always a good idea
- Try **Cutout, MixUp, CutMix, Stochastic Depth, Label Smoothing** to squeeze out a bit of extra performance

Choosing Hyperparameters

Choosing Hyperparameters: Grid Search

Choose several values for each hyperparameter
(Often space choices log-linearly)

Example:

Weight decay: $[1 \times 10^{-4}, 1 \times 10^{-3}, 1 \times 10^{-2}, 1 \times 10^{-1}]$

Learning rate: $[1 \times 10^{-4}, 1 \times 10^{-3}, 1 \times 10^{-2}, 1 \times 10^{-1}]$

Evaluate all possible choices on this hyperparameter grid

Choosing Hyperparameters: Random search

Choose several values for each hyperparameter
(Often space choices log-linearly)

Example:

Weight decay: **log-uniform** on $[1 \times 10^{-4}, 1 \times 10^{-1}]$

Learning rate: **log-uniform** on $[1 \times 10^{-4}, 1 \times 10^{-1}]$

Run many different trials

Random Search vs. Grid Search

*Random Search for
Hyper-Parameter Optimization*
Bergstra and Bengio, 2012

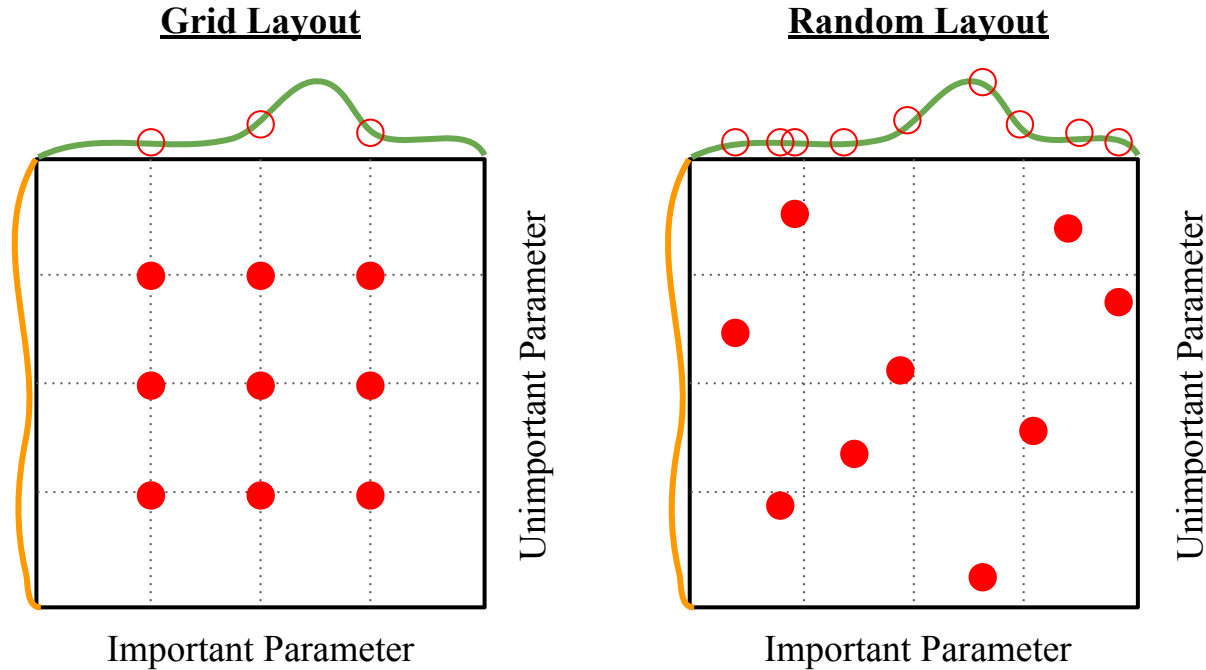

Illustration of Bergstra et al., 2012 by Shayne Longpre, copyright CS231n 2017

Choosing Hyperparameters

(without tons of GPUs)

Choosing Hyperparameters

Step 1: Check initial loss

Turn off weight decay, sanity check loss at initialization
e.g. $\log(C)$ for softmax with C classes

Choosing Hyperparameters

Step 1: Check initial loss

Step 2: Overfit a small sample

Try to train to 100% training accuracy on a small sample of training data (~5-10 minibatches); fiddle with architecture, learning rate, weight initialization

Loss not going down? LR too low, bad initialization

Loss explodes to Inf or NaN? LR too high, bad initialization

Choosing Hyperparameters

Step 1: Check initial loss

Step 2: Overfit a small sample

Step 3: Find LR that makes loss go down

Use the architecture from the previous step, use all training data, turn on small weight decay, find a learning rate that makes the loss drop significantly within ~ 100 iterations

Good learning rates to try: $1e-1$, $1e-2$, $1e-3$, $1e-4$

Choosing Hyperparameters

Step 1: Check initial loss

Step 2: Overfit a small sample

Step 3: Find LR that makes loss go down

Step 4: Coarse grid, train for ~1-5 epochs

Choose a few values of learning rate and weight decay around what worked from Step 3, train a few models for ~1-5 epochs.

Good weight decay to try: $1e-4$, $1e-5$, 0

Choosing Hyperparameters

Step 1: Check initial loss

Step 2: Overfit a small sample

Step 3: Find LR that makes loss go down

Step 4: Coarse grid, train for ~1-5 epochs

Step 5: Refine grid, train longer

Pick best models from Step 4, train them for longer (~10-20 epochs) without learning rate decay

Choosing Hyperparameters

Step 1: Check initial loss

Step 2: Overfit a small sample

Step 3: Find LR that makes loss go down

Step 4: Coarse grid, train for ~1-5 epochs

Step 5: Refine grid, train longer

Step 6: Look at loss and accuracy curves

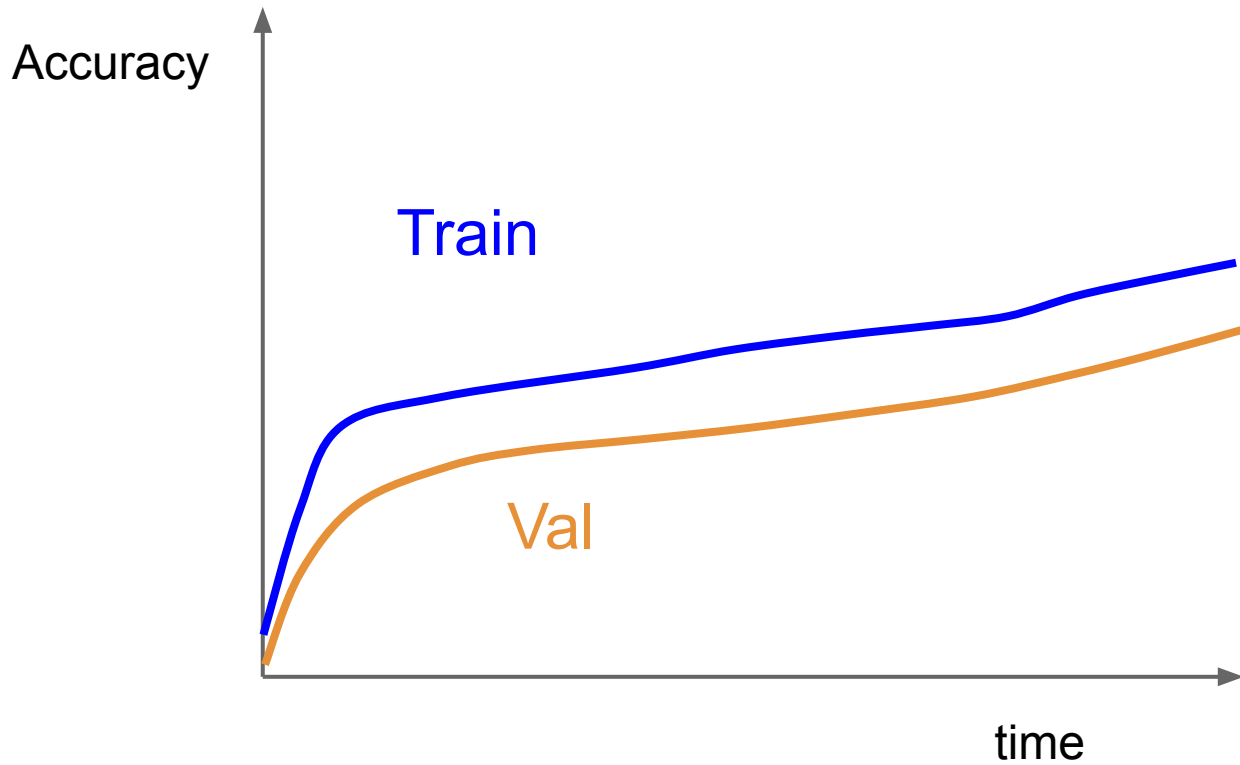

Q1. You see this. What should you do?

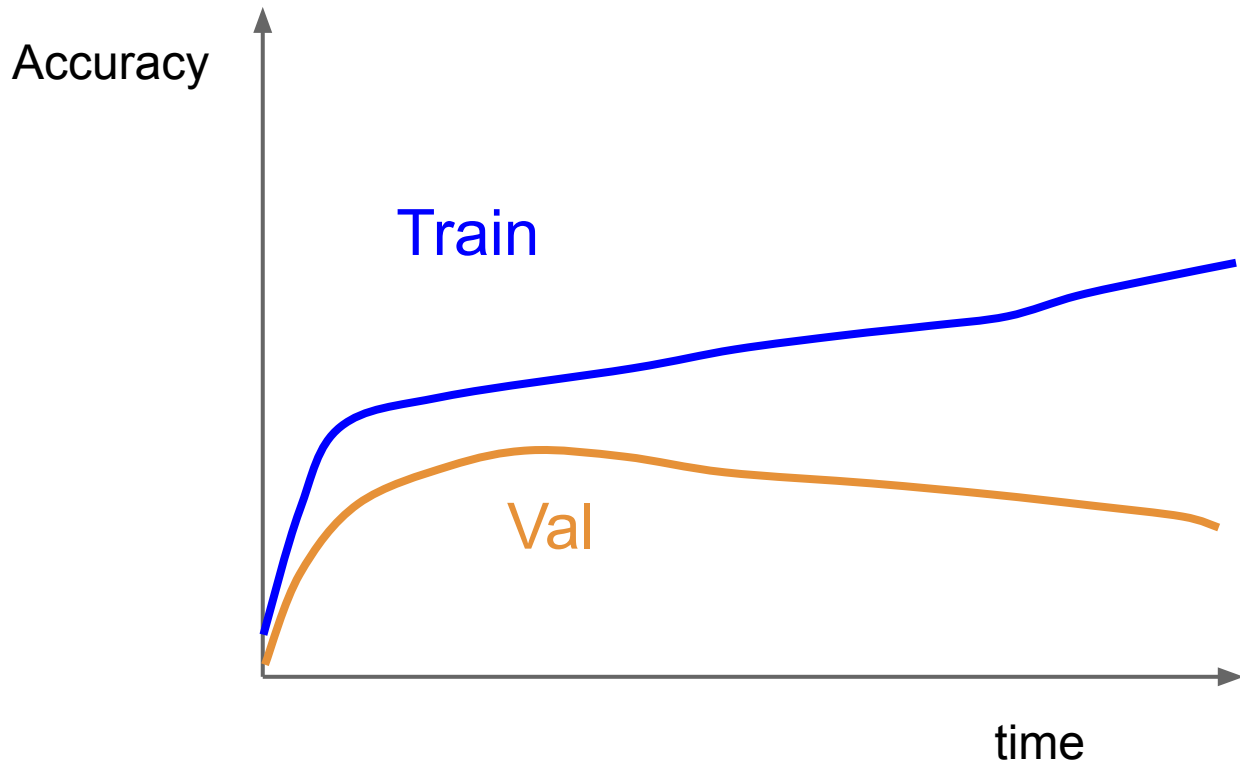

Q2. You see this. What should you do?

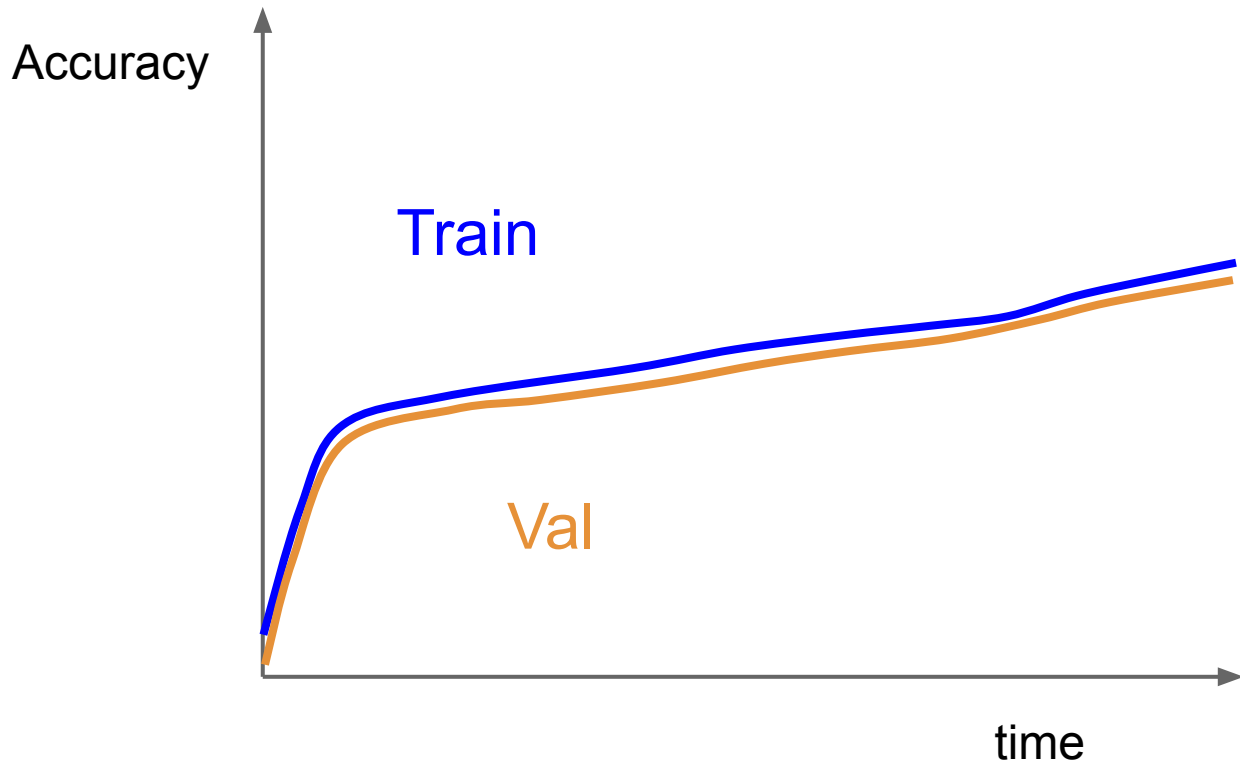

Q3. You see this. What should you do?

Look at learning curves!

Training Loss

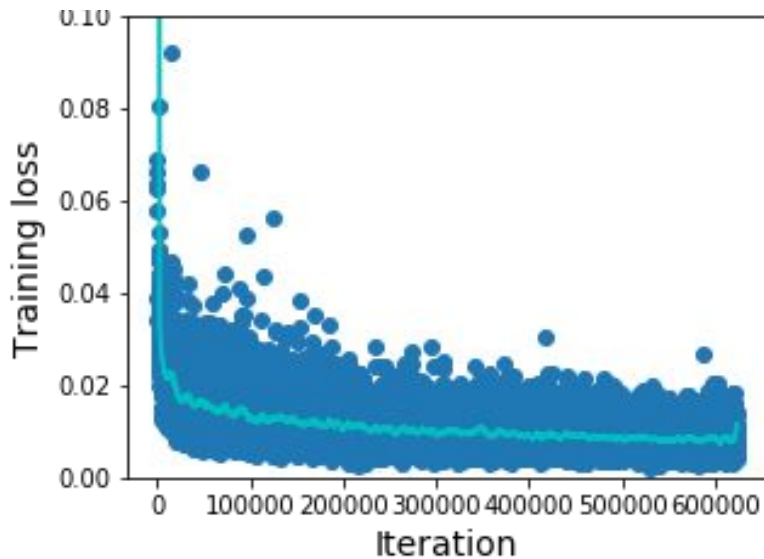

Train / Val Accuracy

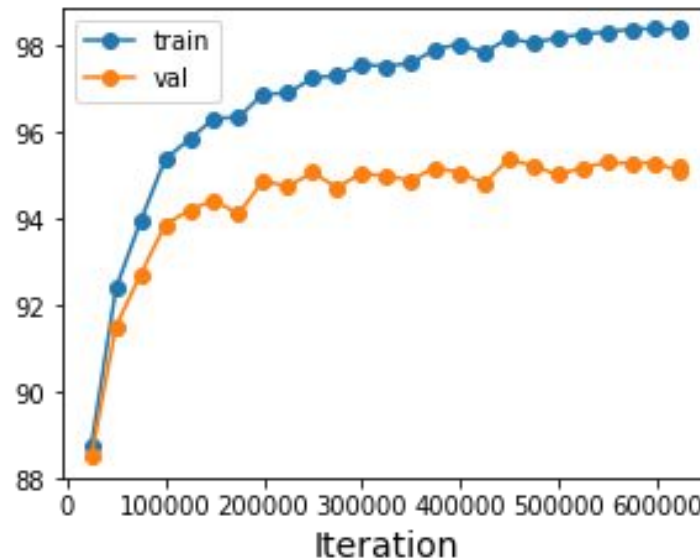

Losses may be noisy, use a scatter plot and also plot moving average to see trends better

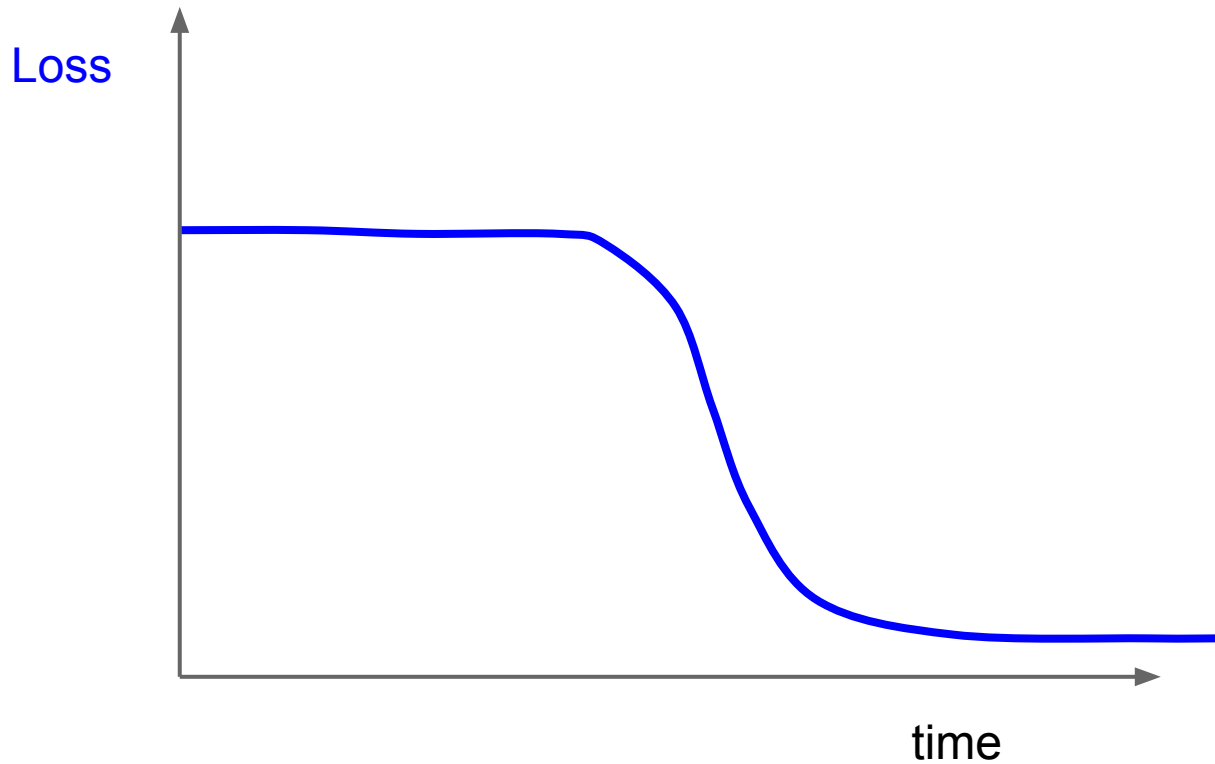

Q4. You see this. What should you do?

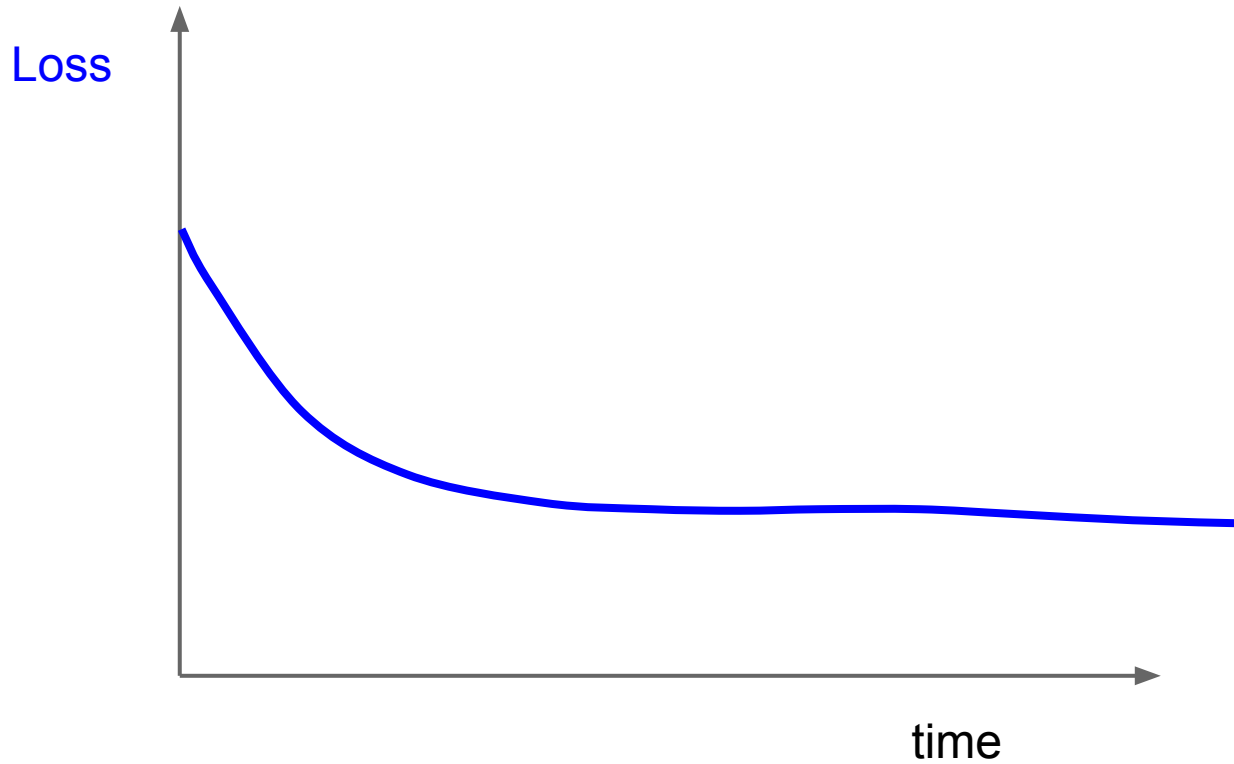

Q5. You see this. What should you do?

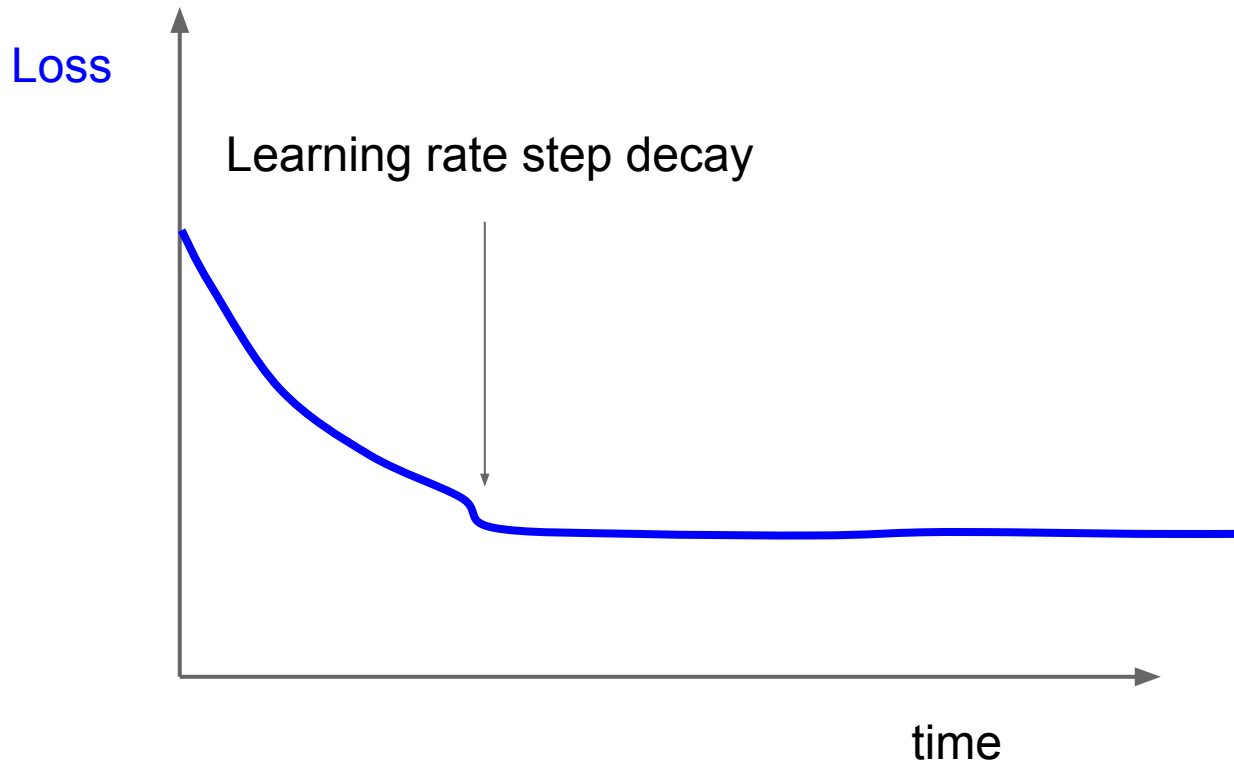

Q5. You see this. What should you do?

Cross-validation

We develop "command centers" to visualize all our models training with different hyperparameters

check out [weights and biases](#)

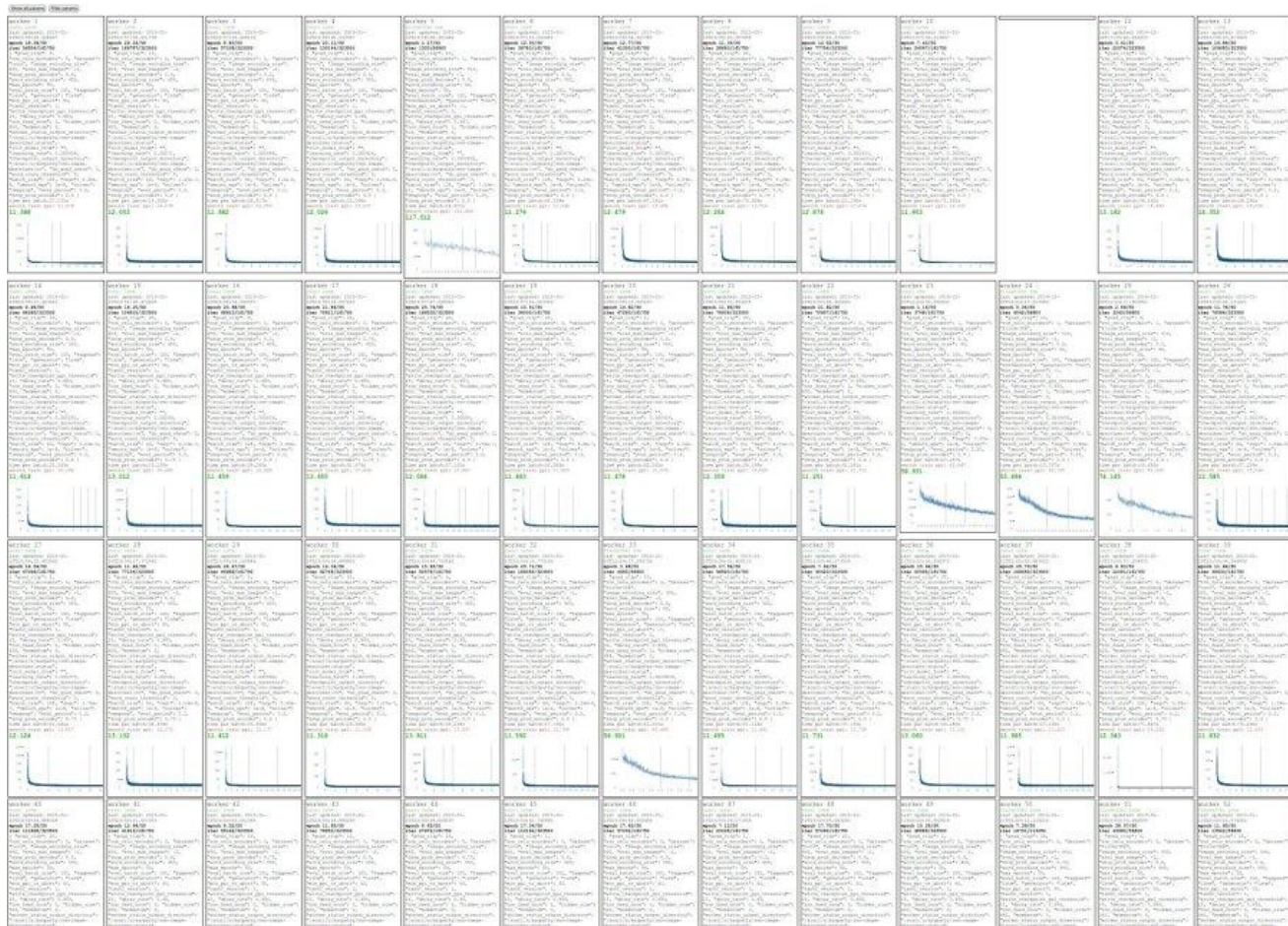

You can plot all your loss curves for different hyperparameters on a single plot

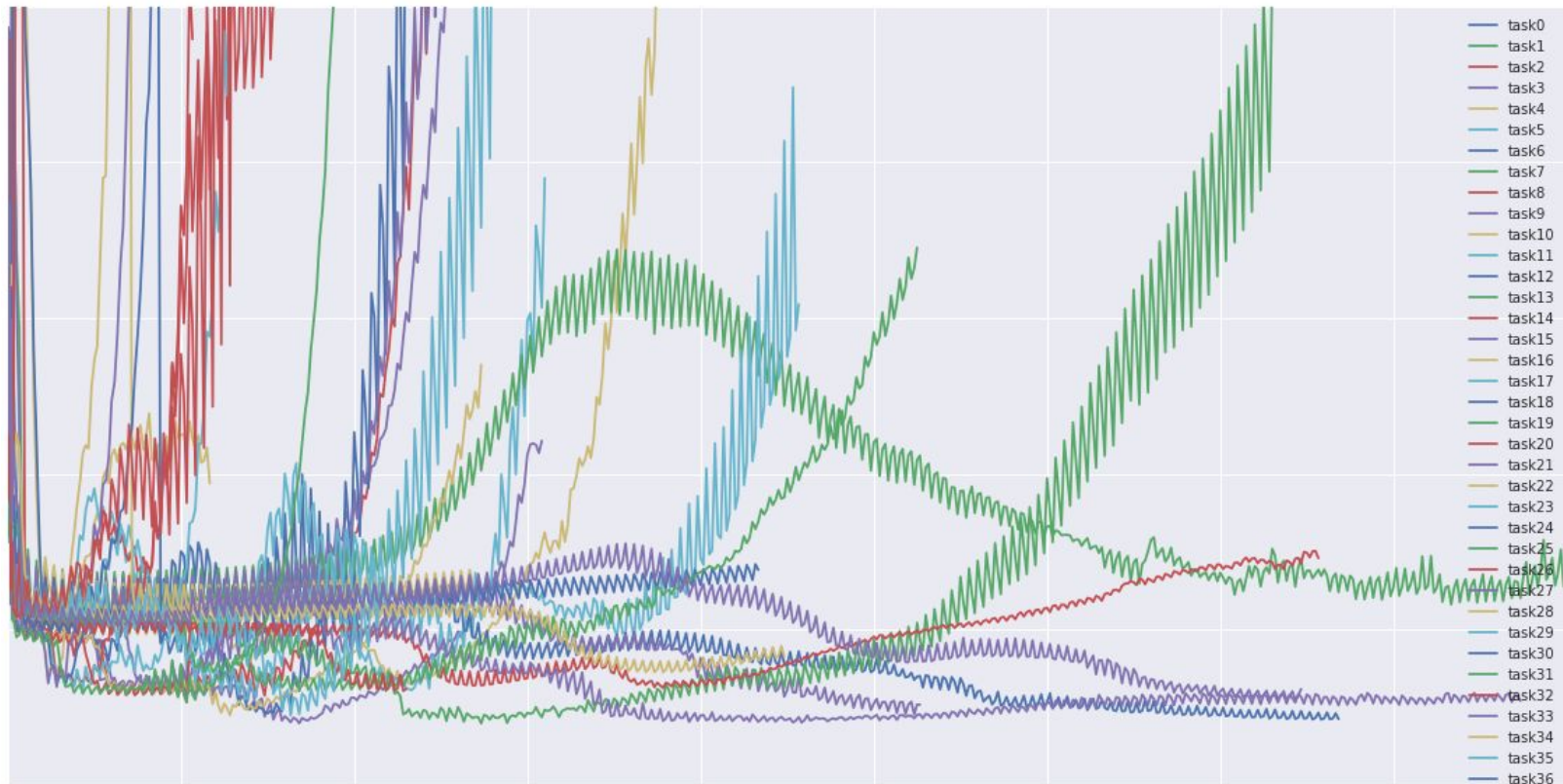

Choosing Hyperparameters

Step 1: Check initial loss

Step 2: Overfit a small sample

Step 3: Find LR that makes loss go down

Step 4: Coarse grid, train for ~1-5 epochs

Step 5: Refine grid, train longer

Step 6: Look at loss and accuracy curves

Step 7: GOTO step 5

Hyperparameters to play with:

- learning rate,
- Its decay schedule, update type
- regularization (L2/Dropout strength)

[This image](#) by Paolo Guereta is licensed under [CC-BY 2.0](#)

Summary

- Improve your training error:
 - Optimizers
 - Learning rate schedules
- Improve your test error:
 - Regularization
 - Choosing Hyperparameters

Next time: Visualizing and
understanding neural networks

Model Ensembles: Tips and Tricks

Instead of training independent models, use multiple snapshots of a single model during training!

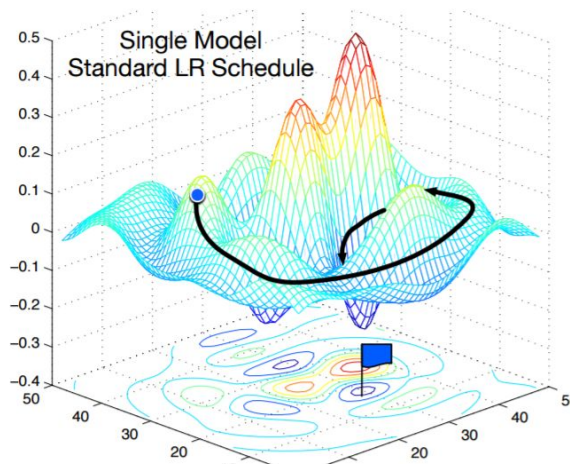

Loshchilov and Hutter, "SGDR: Stochastic gradient descent with restarts", arXiv 2016
Huang et al, "Snapshot ensembles: train 1, get M for free", ICLR 2017
Figures copyright Yixuan Li and Geoff Pleiss, 2017. Reproduced with permission.

Model Ensembles: Tips and Tricks

Instead of training independent models, use multiple snapshots of a single model during training!

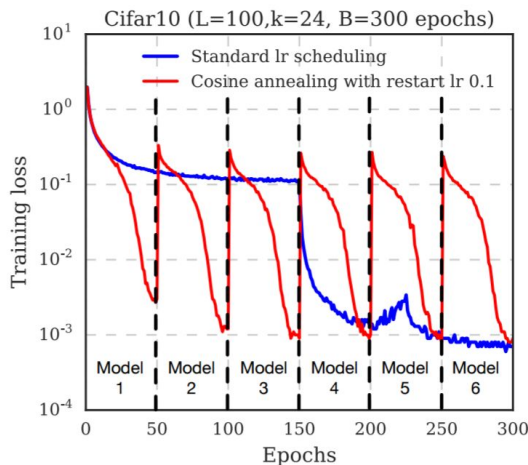
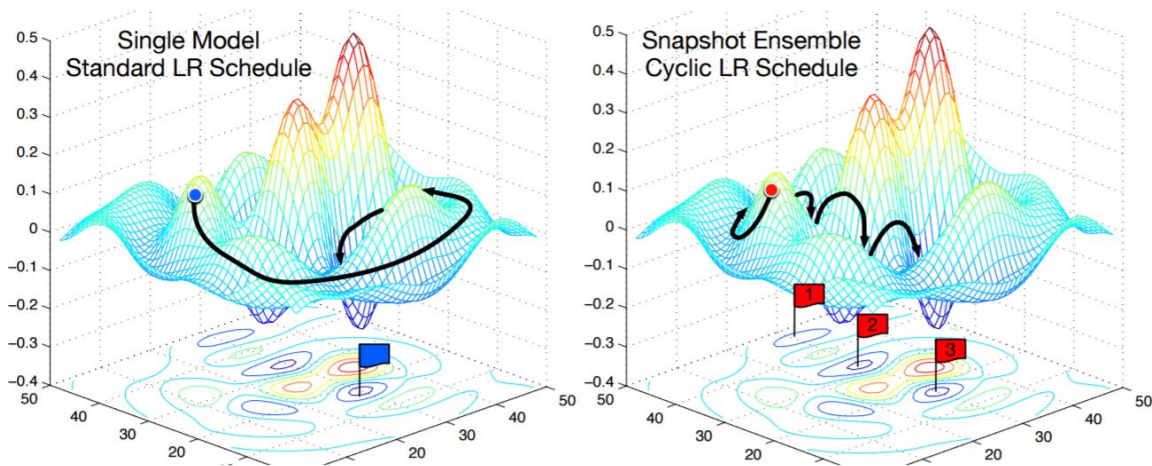

Cyclic learning rate schedules can make this work even better!

Loshchilov and Hutter, "SGDR: Stochastic gradient descent with restarts", arXiv 2016
Huang et al, "Snapshot ensembles: train 1, get M for free", ICLR 2017
Figures copyright Yixuan Li and Geoff Pleiss, 2017. Reproduced with permission.

Model Ensembles: Tips and Tricks

Instead of using actual parameter vector, keep a moving average of the parameter vector and use that at test time (Polyak averaging)

```
while True:
    data_batch = dataset.sample_data_batch()
    loss = network.forward(data_batch)
    dx = network.backward()
    x += - learning_rate * dx
    x_test = 0.995*x_test + 0.005*x # use for test set
```

Polyak and Juditsky, "Acceleration of stochastic approximation by averaging", SIAM Journal on Control and Optimization, 1992.

Track the ratio of weight updates / weight magnitudes:

```
# assume parameter vector W and its gradient vector dW
param_scale = np.linalg.norm(W.ravel())
update = -learning_rate*dW # simple SGD update
update_scale = np.linalg.norm(update.ravel())
W += update # the actual update
print update_scale / param_scale # want ~1e-3
```

ratio between the updates and values: $\sim 0.0002 / 0.02 = 0.01$ (about okay)
want this to be somewhere around 0.001 or so