

CSE 484 / CSE M 584: Computer Security and Privacy

Cryptography

[MACs and Hash Functions]

Spring 2020

Franziska (Franzi) Roesner

franzi@cs.washington.edu

Thanks to Dan Boneh, Dieter Gollmann, Dan Halperin, Yoshi Kohno, Ada Lerner, John Manferdelli, John Mitchell, Vitaly Shmatikov, Bennet Yee, and many others for sample slides and materials ...

Admin

- Additional office hours scheduled
 - 12:30-1:30pm on Fridays
 - A single Zoom room for the whole 12:30-2:30pm timeslot

When is an Encryption Scheme “Secure”?

- Hard to recover the key?
 - What if attacker can learn plaintext without learning the key?
- Hard to recover plaintext from ciphertext?
 - What if attacker learns some bits or some function of bits?

How Can a Cipher Be Attacked?

- Attackers knows ciphertext and encryption algthm
 - What else does the attacker know? Depends on the application in which the cipher is used!

Chosen Plaintext Attack

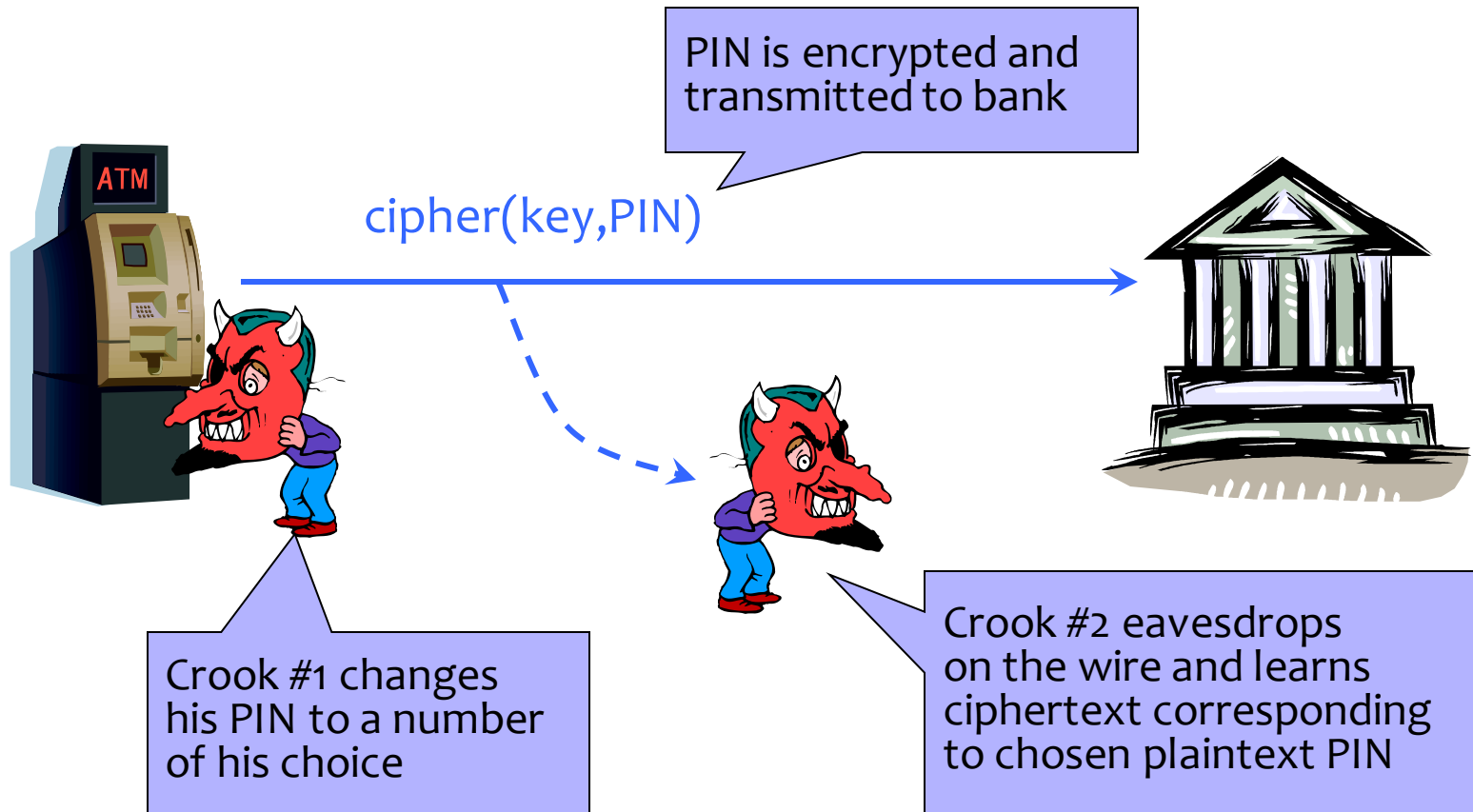

... repeat for any PIN value

How Can a Cipher Be Attacked?

- Attackers knows ciphertext and encryption alghm
 - What else does the attacker know? Depends on the application in which the cipher is used!
- Ciphertext-only attack
- KPA: Known-plaintext attack (stronger)
 - Knows some plaintext-ciphertext pairs
- CPA: Chosen-plaintext attack (even stronger)
 - Can obtain ciphertext for any plaintext of his choice
- CCA: Chosen-ciphertext attack (very strong)
 - Can decrypt any ciphertext except the target

Very Informal Intuition

Minimum security requirement for a modern encryption scheme

- Security against chosen-plaintext attack (CPA)
 - Ciphertext leaks no information about the plaintext
 - Even if the attacker correctly guesses the plaintext, he cannot verify his guess
 - Every ciphertext is unique, encrypting same message twice produces completely different ciphertexts
 - Implication: encryption must be randomized or stateful
- Security against chosen-ciphertext attack (CCA)
 - Integrity protection – it is not possible to change the plaintext by modifying the ciphertext

So Far: Achieving Privacy

Encryption schemes: A tool for protecting **privacy**.

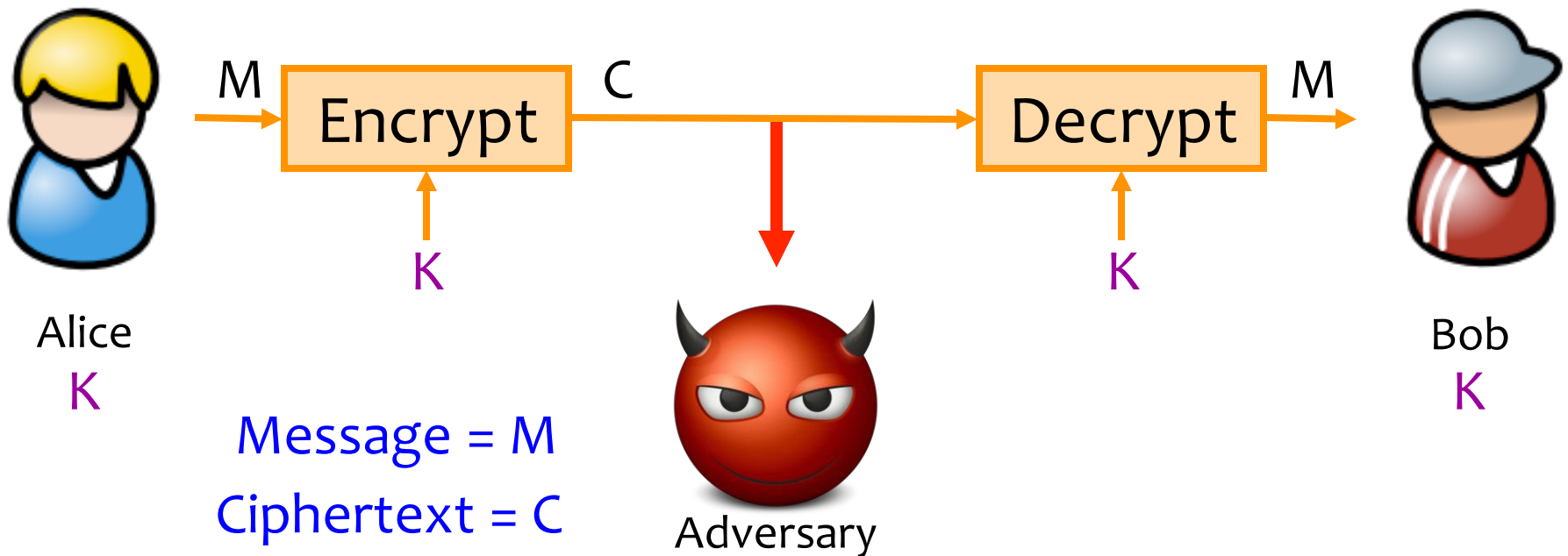

Now: Achieving Integrity

Message authentication schemes: A tool for protecting integrity.

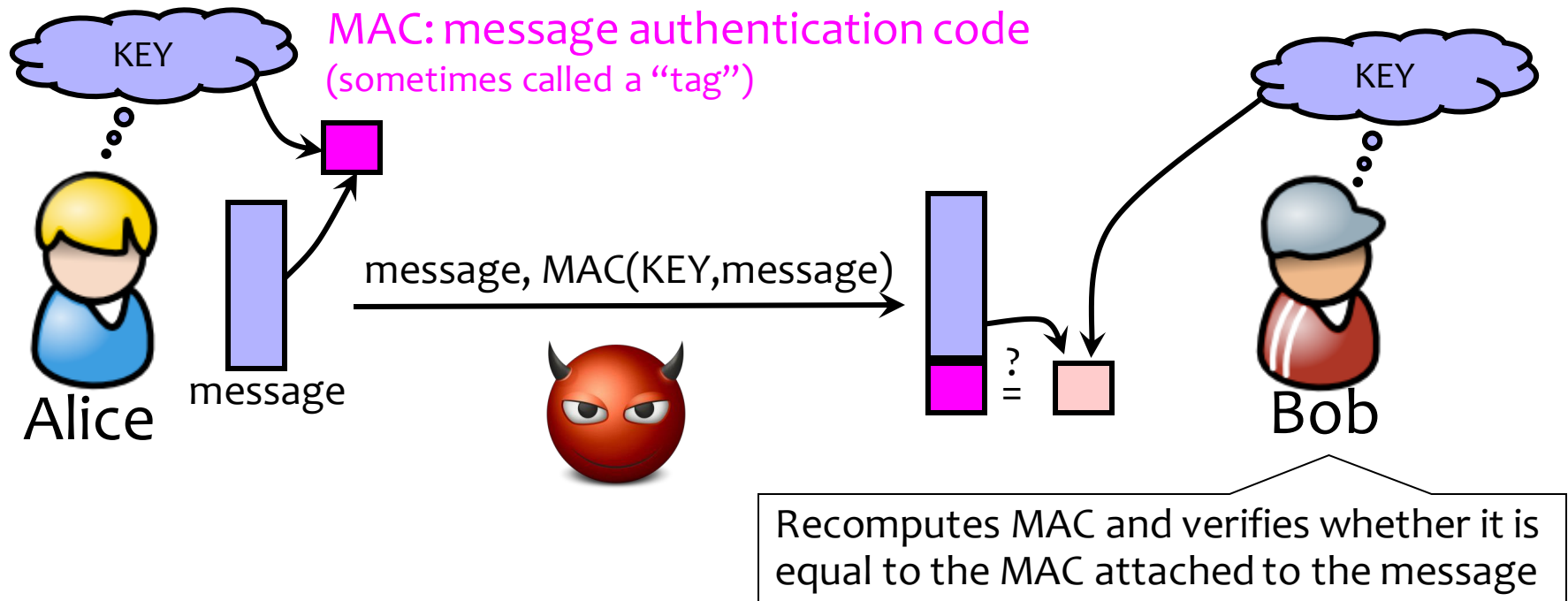

Integrity and authentication: only someone who knows KEY can compute correct MAC for a given message.

Reminder: CBC Mode Encryption

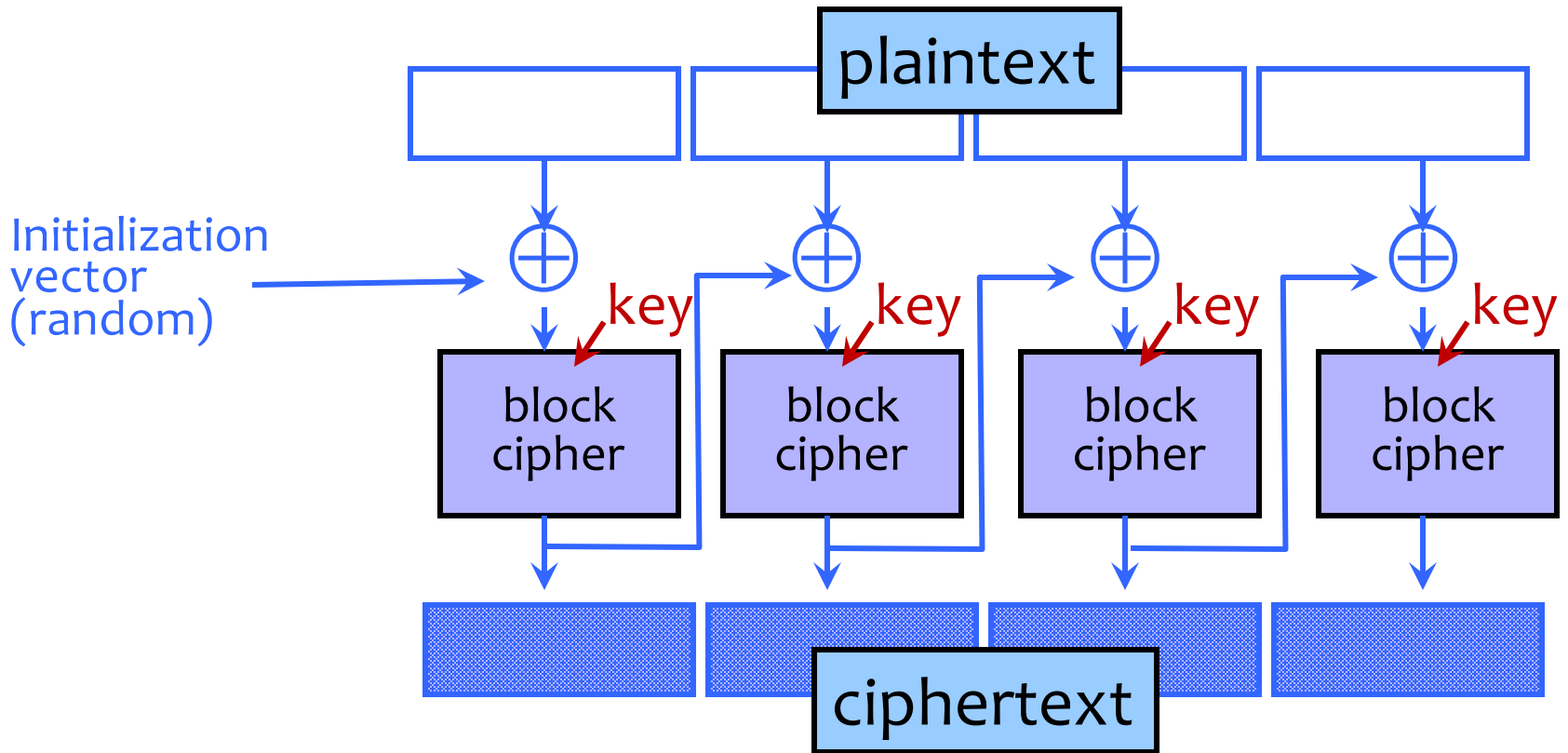

- Identical blocks of plaintext encrypted differently
- Last cipherblock depends on entire plaintext
 - Still does not guarantee integrity

CBC-MAC

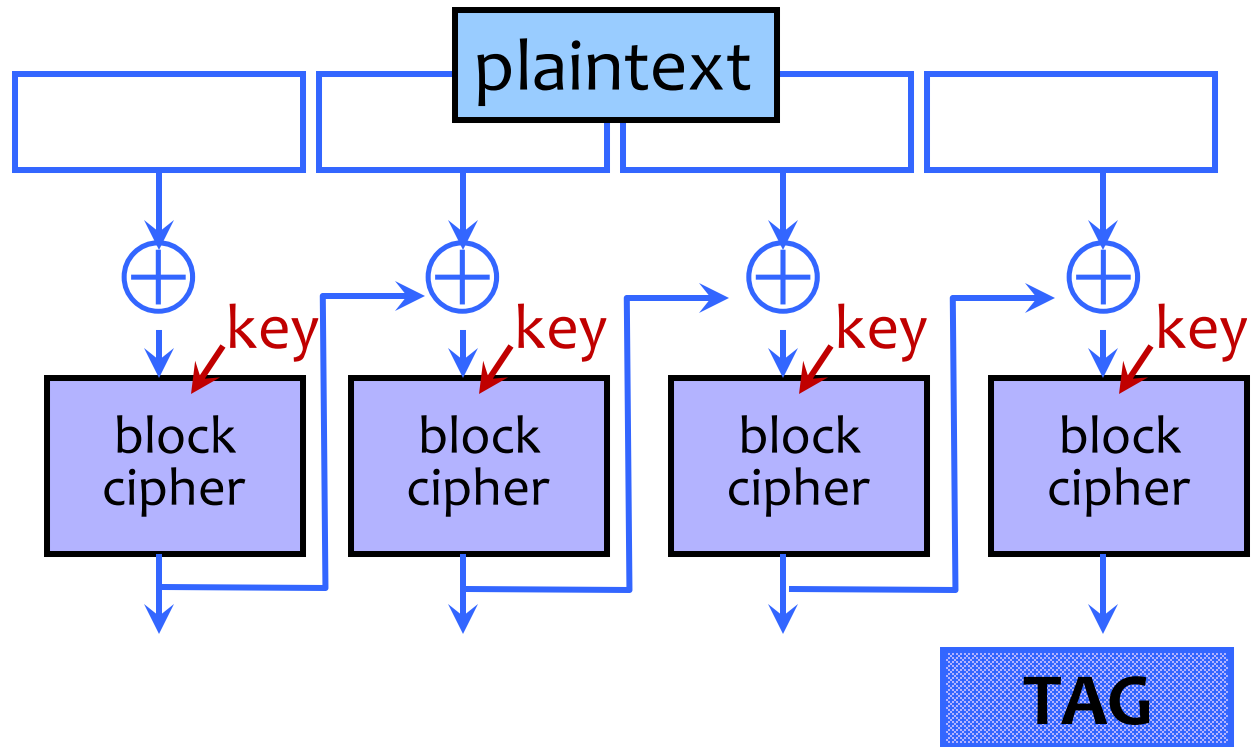

- Not secure when system may MAC messages of different lengths (*more in section!*).
- NIST recommends a derivative called CMAC [FYI only]

Another Tool: Hash Functions

You Just Did This

```
franzi@codered:~/sploits$ md5sum exploit0.c  
3a2e6ce795bce4d06df1ff6835d25cea  exploit0.c  
franzi@codered:~/sploits$ █
```

Hash Functions: Main Idea

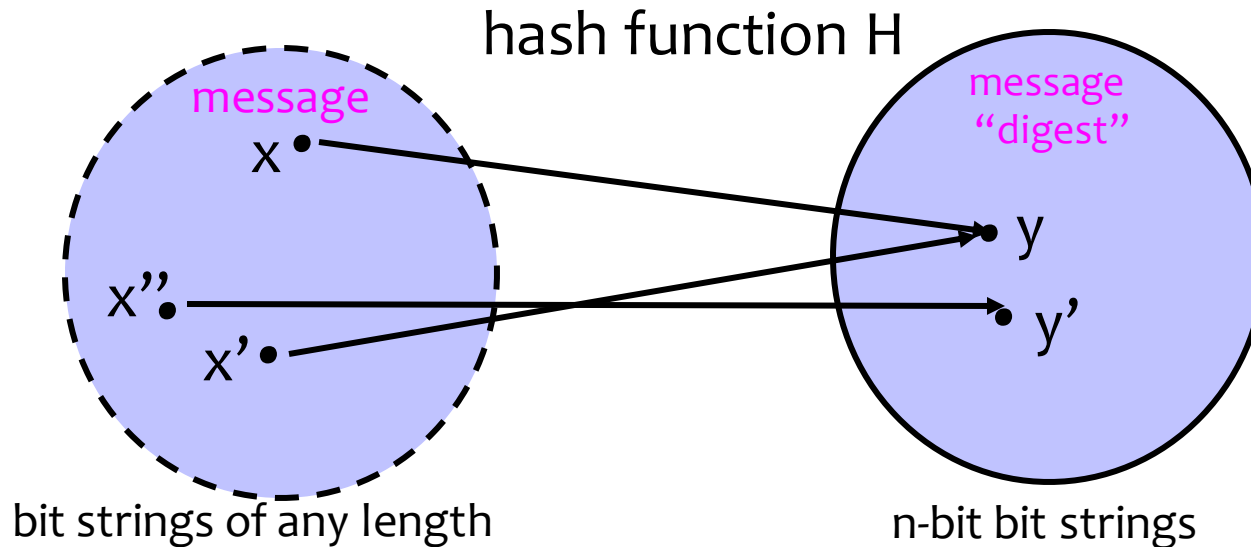

- Hash function H is a lossy compression function
 - Collision: $h(x)=h(x')$ for distinct inputs x, x'
- $H(x)$ should look “random”
 - Every bit (almost) equally likely to be 0 or 1
- Cryptographic hash function needs a few properties...

Property 1: One-Way

- Intuition: hash should be hard to invert
 - “Preimage resistance”
 - Let $h(x') = y \in \{0,1\}^n$ for a random x'
 - Given y , it should be hard to find any x such that $h(x)=y$
- How hard?
 - Brute-force: try every possible x , see if $h(x)=y$
 - SHA-1 (common hash function) has 160-bit output
 - Expect to try 2^{159} inputs before finding one that hashes to y .

Property 2: Collision Resistance

- Should be hard to find $x \neq x'$ such that $h(x) = h(x')$

Birthday Paradox

- Are there two people in the first 1/8 of this class that have the same birthday?
 - 365 days in a year (366 some years)
 - Pick one person. To find another person with same birthday would take on the order of $365/2 = 182.5$ people
 - **Expect birthday “collision” with a room of only 23 people.**
 - For simplicity, approximate when we expect a collision as $\text{sqrt}(365)$.
- Why is this important for cryptography?
 - 2^{128} different 128-bit values
 - Pick one value at random. To exhaustively search for this value requires trying on average 2^{127} values.
 - **Expect “collision” after selecting approximately 2^{64} random values.**
 - **64 bits** of security against collision attacks, not 128 bits.

Property 2: Collision Resistance

- Should be hard to find $x \neq x'$ such that $h(x) = h(x')$
- Birthday paradox means that brute-force collision search is **only $O(2^{n/2})$, not $O(2^n)$**
 - For SHA-1, this means $O(2^{80})$ vs. $O(2^{160})$

One-Way vs. Collision Resistance

One-wayness does not imply collision resistance.

Collision resistance does not imply one-wayness.

You can prove this by constructing a function that has one property but not the other. (Details on next slide, FYI only.)

One-Way vs. Collision Resistance (Details here mainly FYI)

- One-wayness does not imply collision resistance
 - Suppose g is one-way
 - Define $h(x)$ as $g(x')$ where x' is x except the last bit
 - h is one-way (to invert h , must invert g)
 - Collisions for h are easy to find: for any x , $h(x_0)=h(x_1)$
- Collision resistance does not imply one-wayness
 - Suppose g is collision-resistant
 - Define $y=h(x)$ to be $0x$ if x is n -bit long, $1g(x)$ otherwise
 - Collisions for h are hard to find: if y starts with 0 , then there are no collisions, if y starts with 1 , then must find collisions in g
 - h is not one way: half of all y 's (those whose first bit is 0) are easy to invert (how?); random y is invertible with probab. $\frac{1}{2}$

Property 3: Weak Collision Resistance

- Given randomly chosen x , hard to find x' such that $h(x)=h(x')$
 - Attacker must find collision for a specific x . By contrast, to break collision resistance it is enough to find any collision.
 - Brute-force attack requires $O(2^n)$ time
- Weak collision resistance does not imply collision resistance.

Hashing vs. Encryption

- Hashing is one-way. There is no “un-hashing”
 - A ciphertext can be decrypted with a decryption key... hashes have no equivalent of “decryption”
- Hash(x) looks “random” but can be compared for equality with Hash(x’)
 - Hash the same input twice → same hash value
 - Encrypt the same input twice → different ciphertexts
- Cryptographic hashes are also known as “cryptographic checksums” or “message digests”

Application: Password Hashing

- Instead of user password, store `hash(password)`
- When user enters a password, compute its hash and compare with the entry in the password file
- Why is hashing better than encryption here?
- System does not store actual passwords!
- Don't need to worry about where to store the key!
- Cannot go from hash to password!

Application: Password Hashing

- Which property do we need?
 - One-wayness?
 - (At least weak) Collision resistance?
 - Both?

Application: Software Integrity

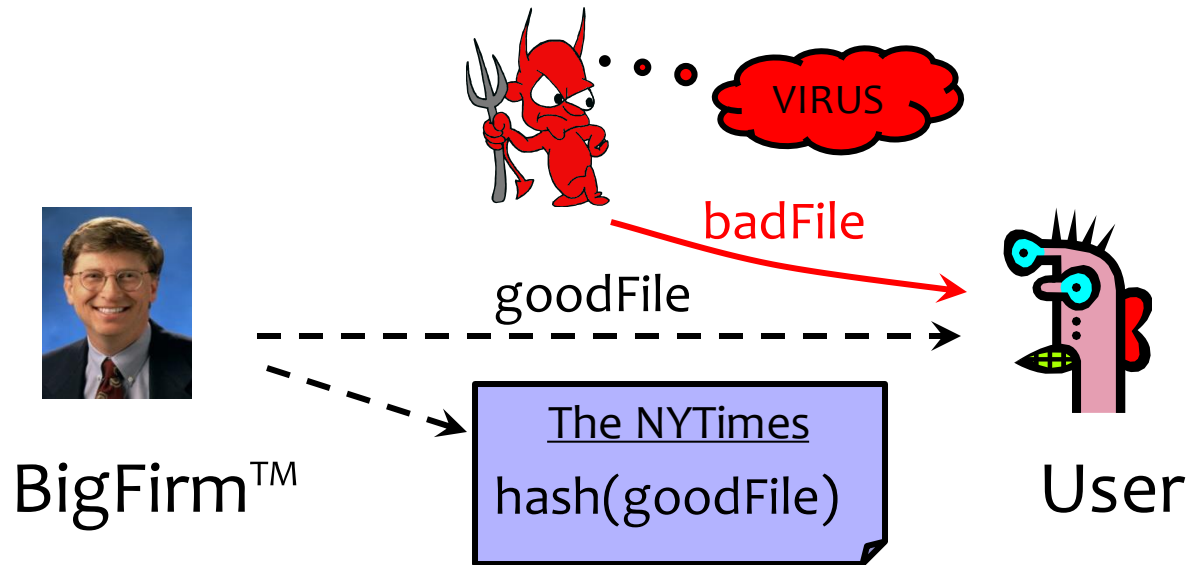

Goal: Software manufacturer wants to ensure file is received by users without modification.

Idea: given goodFile and $\text{hash}(\text{goodFile})$, very hard to find badFile such that $\text{hash}(\text{goodFile}) = \text{hash}(\text{badFile})$

Application: Software Integrity

- Which property do we need?
 - One-wayness?
 - (At least weak) Collision resistance?
 - Both?

Which Property Do We Need?

One-wayness, Collision Resistance, Weak CR?

- UNIX passwords stored as hash(password)
 - **One-wayness:** hard to recover the/a valid password
- Integrity of software distribution
 - **Weak collision resistance**
 - But software images are not really random... may need **full collision resistance** if considering malicious developers

Which Property Do We Need?

- UNIX passwords stored as $\text{hash}(\text{password})$
 - **One-wayness:** hard to recover the/a valid password
- Integrity of software distribution
 - **Weak collision resistance**
 - But software images are not really random... may need **full collision resistance** if considering malicious developers
- Private auction bidding
 - Alice wants to bid B , sends $H(B)$, later reveals B
 - **One-wayness:** rival bidders should not recover B (this may mean that she needs to hash some randomness with B too)
 - **Collision resistance:** Alice should not be able to change her mind to bid B' such that $H(B)=H(B')$