

Courtesy reminder: Make use of office hours – we're here to help! 😊
Remember: 50% is meeting expectations. >50% is exceeding expectations.

Data Science at Scale: MapReduce & Spark

CSE481DS Data Science Capstone

Tim Althoff



PAUL G. ALLEN SCHOOL
OF COMPUTER SCIENCE & ENGINEERING

**Thank you for sharing
your feedback with us!**

[https://bit.ly/cse481ds-
feedback](https://bit.ly/cse481ds-feedback)

Group Reflection on Process & Validity

Lecture: Distributed Computing for Data Science

Agenda

- **Commodity Computing**

Computing with thousands of failures a day

- **Map Reduce**

Plumbing for billions of data points

- **Spark**

A great tool for a nasty problem

- **Data Engineering in Practice**

What to look forward to

- **Lab!**



Commodity Computing

Large-scale Computing

- **Large-scale computing for data mining problems on commodity hardware**
- **Challenges:**
 - **How do you distribute computation?**
 - **How can we make it easy to write distributed programs?**
 - **Machines fail:**
 - One server may stay up 3 years (1,000 days)
 - If you have 1,000 servers, expect to lose 1/day
 - With 1M machines 1,000 machines fail every day!

Storage Infrastructure

- **Problem:**

- If nodes fail, how to store data persistently?

- **Answer:**

- **Distributed File System**

- Provides global file namespace

- **Typical usage pattern:**

- Huge files (100s of GB to TB)
- Data is rarely updated in place
- Reads and appends are common

Distributed File System

- **Reliable distributed file system**
- Data kept in “chunks” spread across machines
- Each chunk **replicated** on different machines
 - Seamless recovery from disk or machine failure

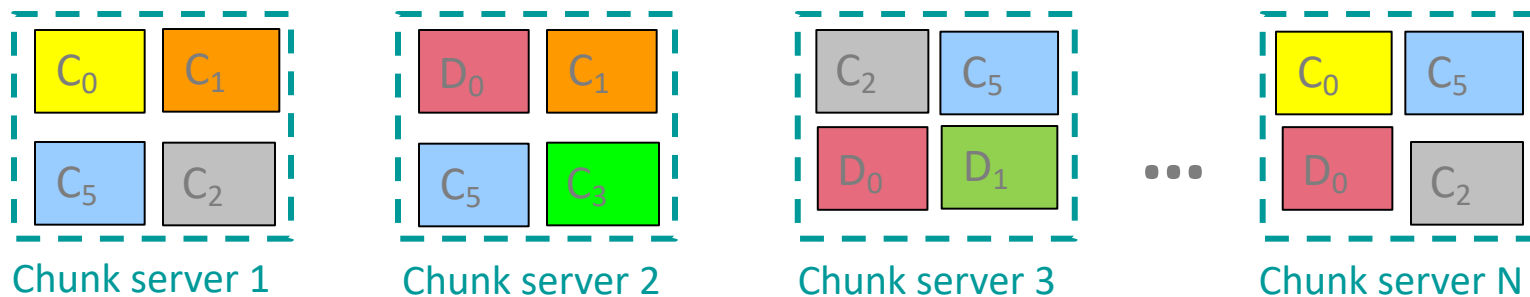

Bring computation directly to the data!

Chunk servers also serve as compute servers

An Issue and a Solution

- **Issue:**

Copying data over a network takes time

- **Idea:**

- Bring computation to data
- Store files multiple times for reliability

- **Map Reduce** address these problems

- **Storage Infrastructure – File system**

- Google: GFS. Hadoop: HDFS

- **Programming model**

- MapReduce
- Spark

Programming Model

- **MapReduce is a **style of programming** designed for:**
 1. Easy parallel programming
 2. Invisible management of hardware and software failures
 3. Easy management of very-large-scale data
- It has several **implementations**, including Hadoop, Spark (used in this class), Flink, and the original Google implementation just called “MapReduce”

MapReduce: Overview

3 steps of MapReduce

■ Map:

- Apply a user-written *Map function* to each input element
 - *Mapper* applies the Map function to a single element
 - Many mappers grouped in a *Map task* (the unit of parallelism)
 - The output of the Map function is a set of 0, 1, or more *key-value pairs*.

■ Group by key: Sort and shuffle

- System sorts all the key-value pairs by key, and outputs key-(list of values) pairs

■ Reduce:

- User-written *Reduce function* is applied to each key-(list of values)

Outline stays the same, Map and Reduce change to fit the problem

Map-Reduce: A diagram

Input

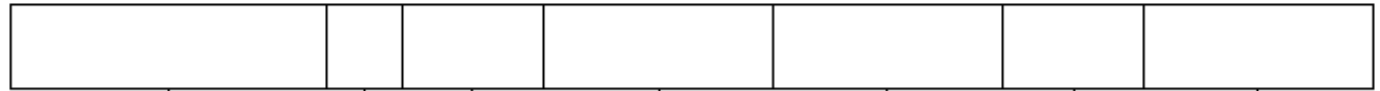

MAP:
Read input and produces a set of key-value pairs

Intermediate

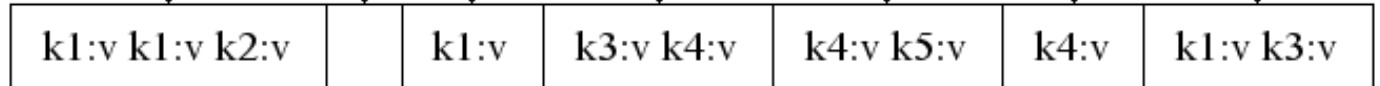

Group by key:
Collect all pairs with same key
(Hash merge, Shuffle, Sort, Partition)

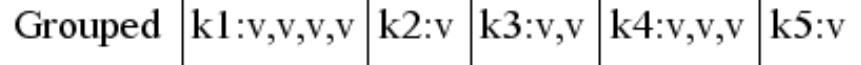
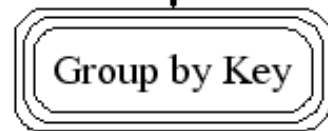

Reduce:
Collect all values belonging to the key and output

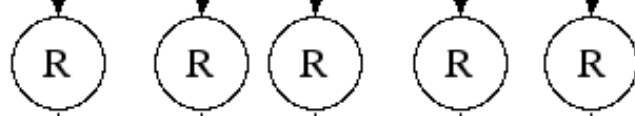

Output

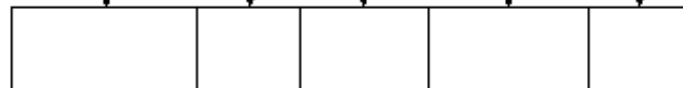

Example: Word Counting

Example MapReduce task:

- We have a huge text document
- Count the number of times each distinct word appears in the file
- **Many applications of this:**
 - Analyze web server logs to find popular URLs
 - Statistical machine translation:
 - Need to count number of times every 5-word sequence occurs in a large corpus of documents

MapReduce: Word Counting

Provided by the programmer

MAP:
Read input and produces a set of key-value pairs

(The, 1)
(crew, 1)
(of, 1)
(the, 1)
(space, 1)
(shuttle, 1)
(Endeavor, 1)
(recently, 1)
....

(key, value)

Group by key:
Collect all pairs with same key

(crew, 1)
(crew, 1)
(space, 1)
(the, 1)
(the, 1)
(the, 1)
(shuttle, 1)
(recently, 1)
...

(key, value)

Provided by the programmer

Reduce:
Collect all values belonging to the key and output

(crew, 2)
(space, 1)
(the, 3)
(shuttle, 1)
(recently, 1)
...

(key, value)

The crew of the space shuttle Endeavor recently returned to Earth as ambassadors, harbingers of a new era of space exploration. Scientists at NASA are saying that the recent assembly of the Dextre bot is the first step in a long-term space-based man/machine partnership. "The work we're doing now -- the robotics we're doing - is what we're going to need

Big document

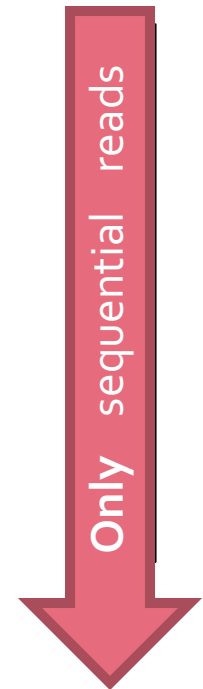

Word Count Using MapReduce

map(key, value) :

```
# key: document name; value: text of the document
  for each word w in value:
    emit(w, 1)
```

reduce(key, values) :

```
# key: a word; value: an iterator over counts
  result = 0
  for each count v in values:
    result += v
  emit(key, result)
```

Map-Reduce: In Parallel

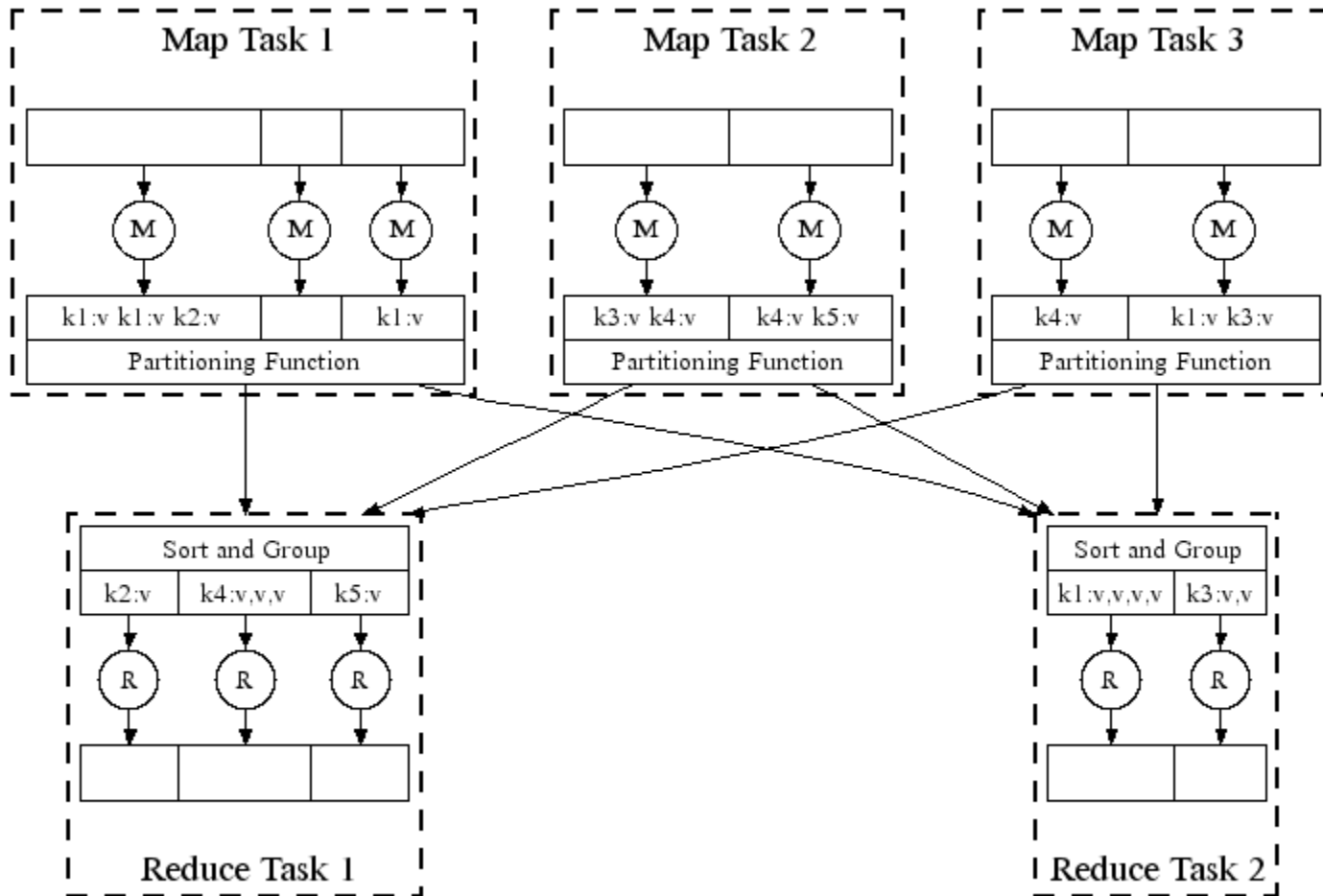

All phases are distributed with many tasks doing the work

MapReduce Pattern

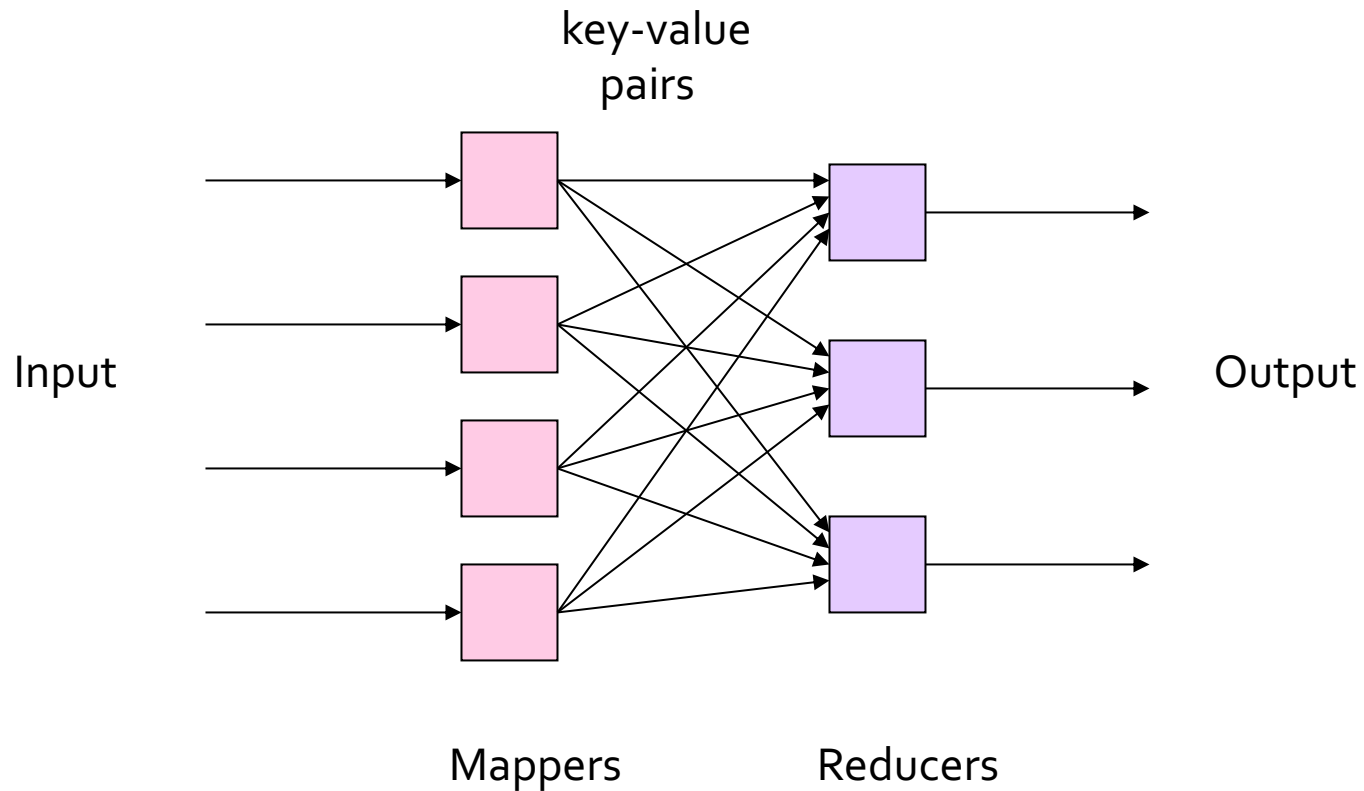

MapReduce: Environment

MapReduce environment takes care of:

- **Partitioning** the input data
- **Scheduling** the program's execution across a set of machines
- Performing the **group by key** step
 - In practice this is the bottleneck
- Handling machine **failures**
- Managing required inter-machine **communication**

Dealing with Failures

- **Map worker failure**
 - Map tasks completed or in-progress at worker are reset to idle and rescheduled
 - Reduce workers are notified when map task is rescheduled on another worker
- **Reduce worker failure**
 - Only in-progress tasks are reset to idle and the reduce task is restarted

Spark

Problems with MapReduce

- **Two major limitations of MapReduce:**
 - Difficulty of programming directly in MR
 - Many problems aren't easily described as map-reduce
 - Performance bottlenecks, or batch not fitting the use cases
 - Persistence to disk typically slower than in-memory work
- **In short, MR doesn't compose well for large applications**
 - Many times one needs to chain multiple map-reduce steps

Data-Flow Systems

- **MapReduce uses two “ranks” of tasks:**
One for Map the second for Reduce
 - Data flows from the first rank to the second
- **Data-Flow Systems generalize this in two ways:**
 1. Allow any number of tasks/ranks
 2. Allow functions other than Map and Reduce
 - As long as data flow is in one direction only, we can have the blocking property and allow recovery of tasks rather than whole jobs

Spark: Most Popular Data-Flow System

- **Expressive computing system, not limited to the map-reduce model**
- **Additions to MapReduce model:**
 - Fast data sharing
 - Avoids saving intermediate results to disk
 - Caches data for repetitive queries (e.g. for machine learning)
 - General execution graphs (DAGs)
 - Richer functions than just map and reduce
- **Compatible with Hadoop**

Spark: Overview

- Open source software (Apache Foundation)
- Supports **Java, Scala and Python**
- **Key construct/idea:** Resilient Distributed Dataset (RDD)
- **Higher-level APIs:** DataFrames & DataSets
 - Introduced in more recent versions of Spark
 - Different APIs for aggregate data, which allowed to introduce SQL support

Spark: RDD

Key concept *Resilient Distributed Dataset* (RDD)

- Partitioned collection of records
 - Generalizes (key-value) pairs
- Spread across the cluster, **Read-only**
- Caching dataset in memory
 - Different storage levels available
 - Fallback to disk possible
- RDDs can be created from Hadoop, or by transforming other RDDs (you can stack RDDs)
- RDDs are best suited for applications that apply the same operation to all elements of a dataset

Spark RDD Operations

- **Transformations** build RDDs through deterministic operations on other RDDs:
 - Transformations include *map*, *filter*, *join*, *union*, *intersection*, *distinct*
 - **Lazy evaluation:** Nothing computed until an action requires it
- **Actions** to return value or export data
 - Actions include *count*, *collect*, *reduce*, *save*
 - Actions can be applied to RDDs; actions force calculations and return values

Task Scheduler: General DAGs

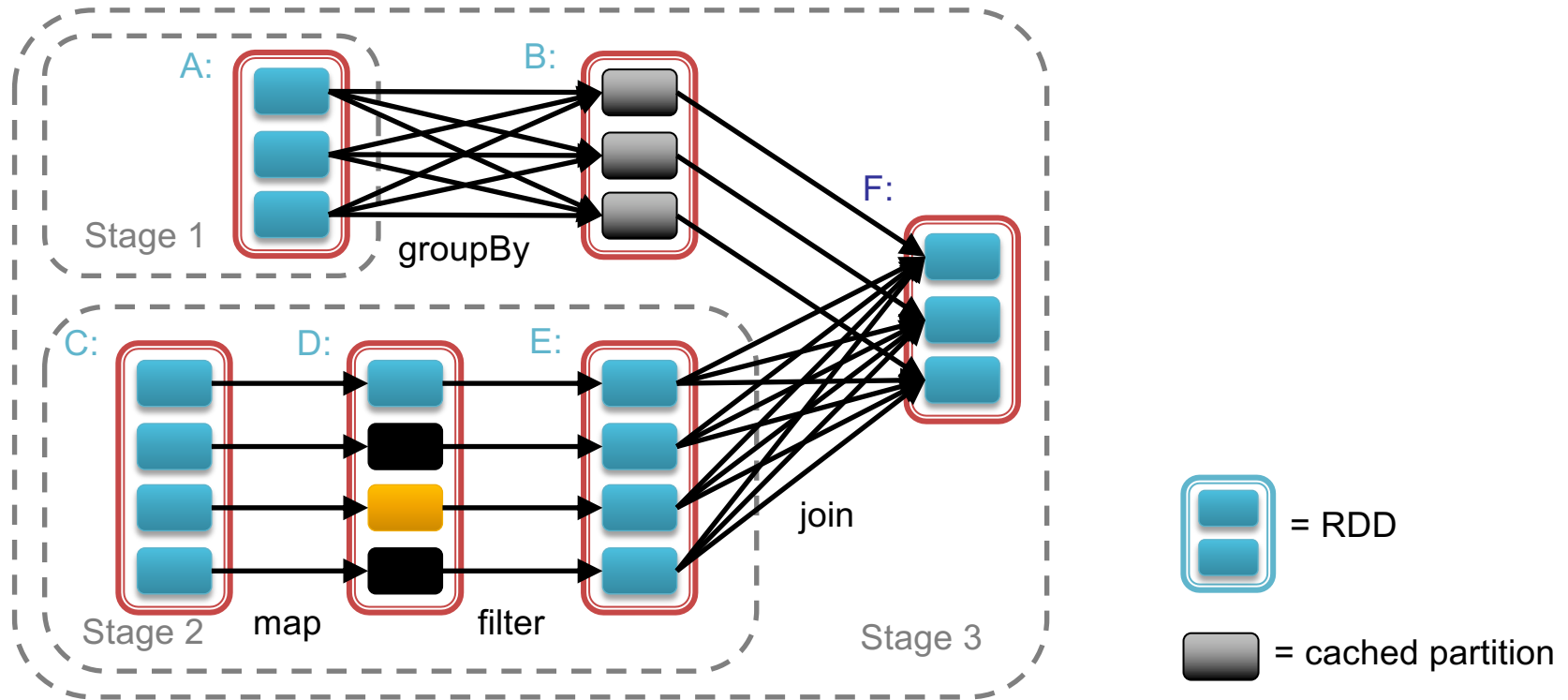

- Supports general task graphs
- Pipelines functions where possible
- Cache-aware data reuse & locality
- Partitioning-aware to avoid shuffles

DataFrame & Dataset

- DataFrame:
 - Unlike an RDD, data organized into named columns, e.g. a **table in a relational database**.
 - Imposes a structure onto a distributed collection of data, allowing higher-level abstraction
- Dataset:
 - Extension of DataFrame API which provides **type-safe, object-oriented programming interface** (compile-time error detection)

Both built on Spark SQL engine. Both can be converted back to an RDD

Spark vs. Hadoop MapReduce

- Performance: **Spark normally faster** but **with caveats**
 - Spark can process data in-memory; Hadoop MapReduce persists back to the disk after a map or reduce action
 - Spark generally outperforms MapReduce, but it **often needs lots of memory to perform well**; if there are other resource-demanding services or can't fit in memory, Spark degrades
 - MapReduce easily runs alongside other services with minor performance differences, & works well with the 1-pass jobs it was designed for
- Ease of use: **Spark is easier to program** (higher-level APIs)
- Data processing: **Spark is more general**

Data Engineering in Practice

Data Analytics Software Stack

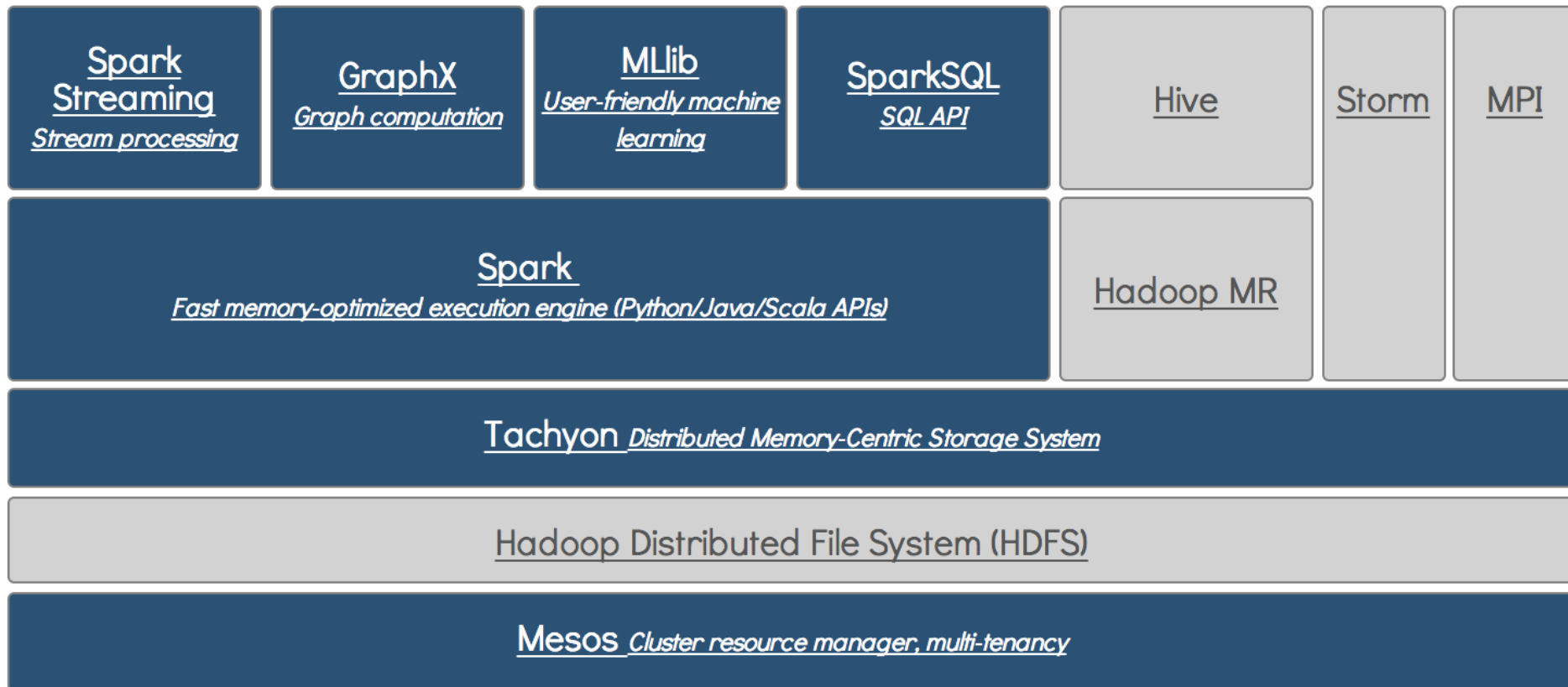

Some other technologies to keep an eye on...



Pros: Map Reduce with Pandas API
Cons: Unstable, Not much support



Amazon Athena



Pros: Map Reduce via SQL, integrations
Cons: Not as flexible



Pros: Loads of integrations, promises a lot
Cons: New-ish player, lots of development ahead

5 min break 😊

**Thank you for sharing
your feedback with us!**

[https://bit.ly/cse481ds-
feedback](https://bit.ly/cse481ds-feedback)

Lab Part: Intro to Spark