



Autonomous Robotics

Spring 2026

Abhishek Gupta, **Siddhartha Srinivasa**

TAs: Helen Wang (lead), Rohan Baijal,
Sidharth Talia, Christopher Tan



Ok so what is CSE 478 about?

We will be programming RACECARs!



RACECAR 1.0



RACECAR 2.0



RACECAR 3.0



Multi-agent System for
non-Holonomic Racing

<https://mushr.io>





Overview of the RACECAR

Intel Realsense D435i

YDLidar X4

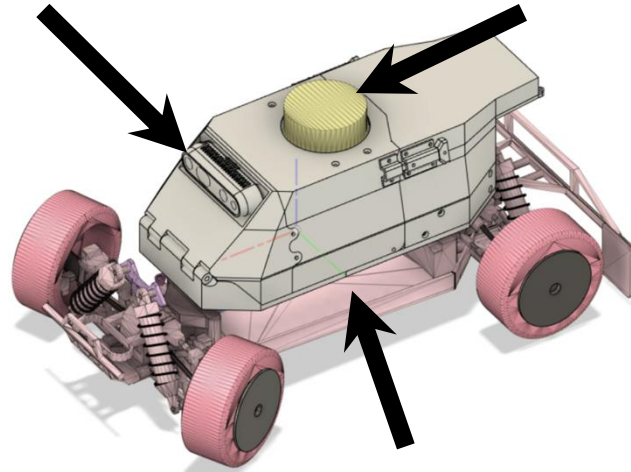

Redcat Racing Blackout SC 1/10 chassis

Nvidia Jetson Orin NX

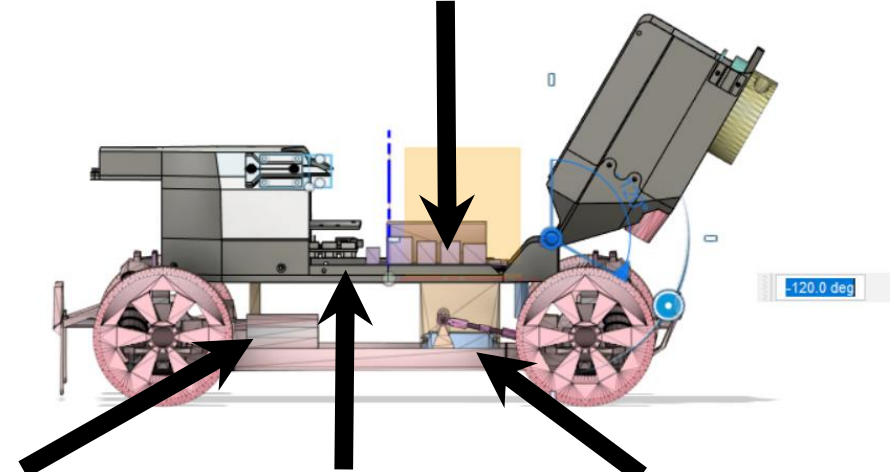

BLDC motor

Motor Driver

Servo





UNIVERSITY *of* WASHINGTON

Introducing
Hound

1x

Demo:

Given a known map of the
environment,
follow a series of waypoints while
avoiding obstacles

Highlights from Previous Years



Video credit: Max Thompson

Thanks to Sanjiban Choudhury, Gilwoo Lee, Matt Schmittle, Matthew Rockett!

Learning Objectives

Objective 1

Learn **algorithms** for
autonomous driving and
implement them on the RACECAR

in 10 weeks!

Objective 2

Learn a **small** set of
fundamental tools

that solve a **wide** range
of robotics problems

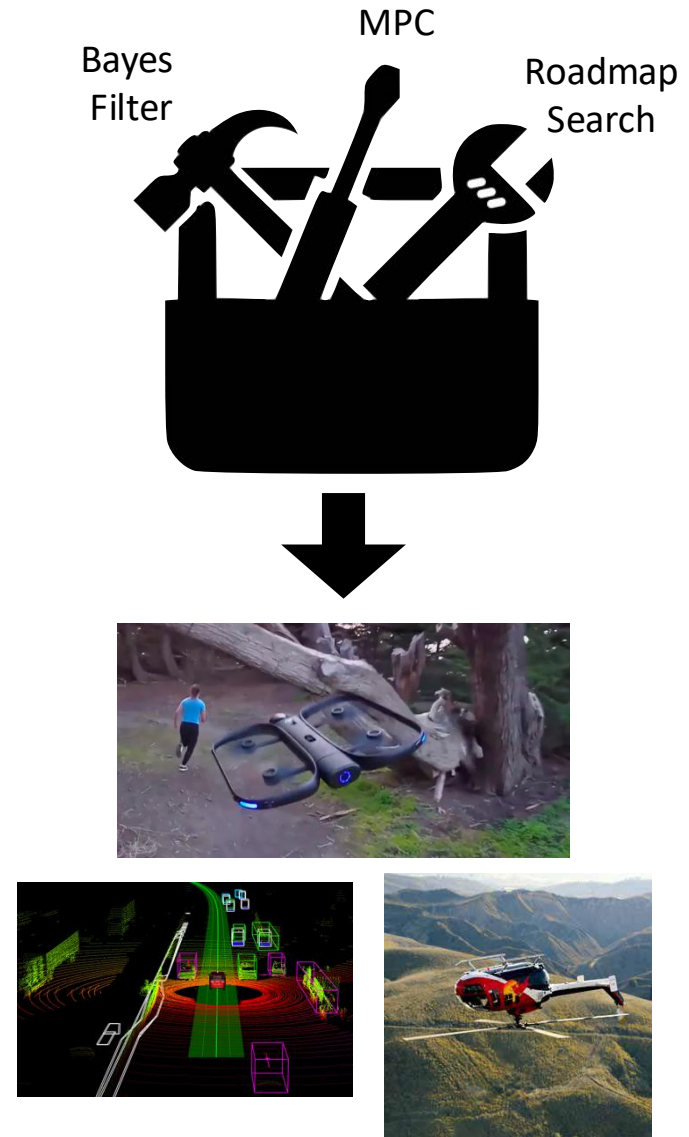

An iceberg floating in a blue ocean under a blue sky with white clouds. The tip of the iceberg is above the water, while the much larger, jagged base is submerged. The text labels are positioned to the right of the iceberg, with 'Mobile Robots' at the top, 'Robot Manipulators' in the middle, 'Humanoids' below that, and 'Soft Robots' at the bottom.

Mobile Robots

Robot Manipulators

Humanoids

Soft Robots

Localization

Planning

Control

Reinforcement/Imitation Learning



Mapping

Computer Vision

Robot and Actuator Design

Concrete Learning Objectives

Estimate
State

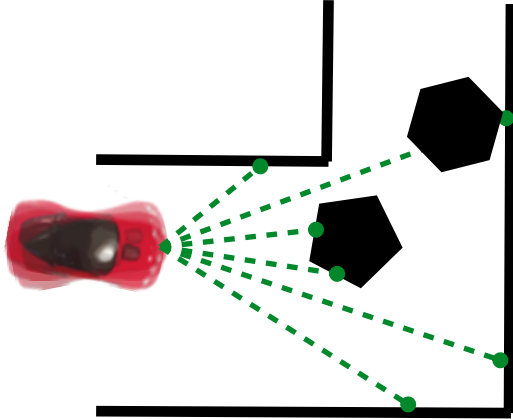

Plan a sequence
of motions

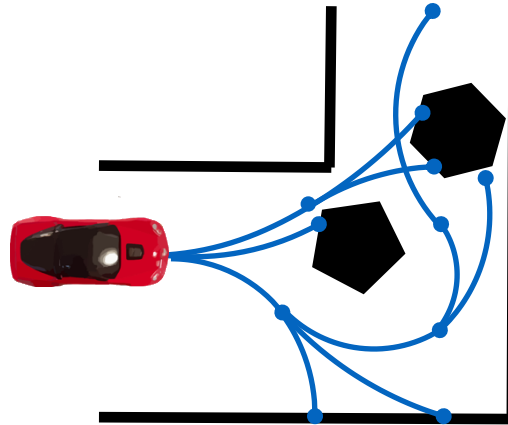

Control robot to
follow plan

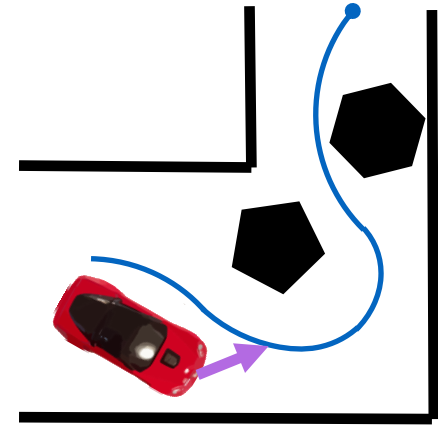

Additional Learning Objectives – no HW

How to estimate maps

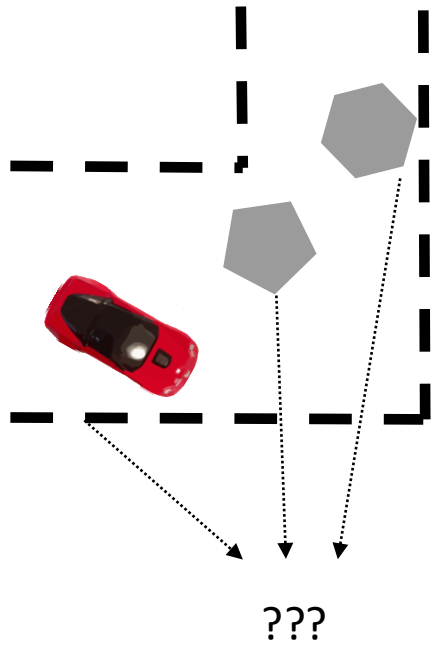

Where machine learning may be helpful?

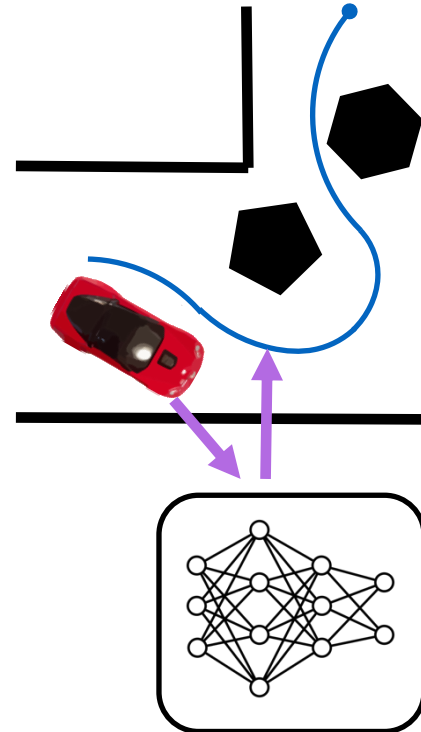

Learn how to program robot software





TW

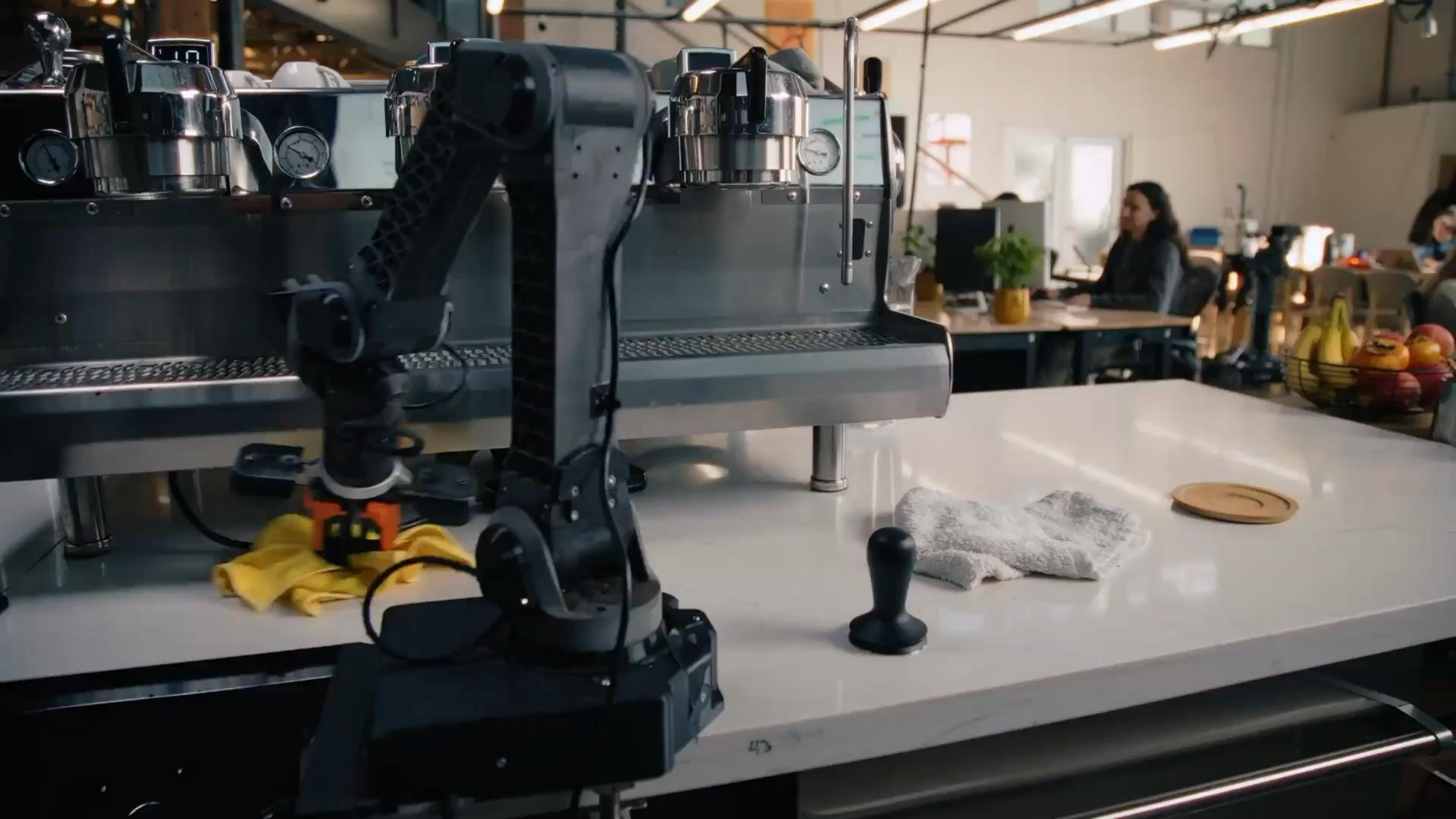

Objective 3

Learn how to read and analyze and propose research papers

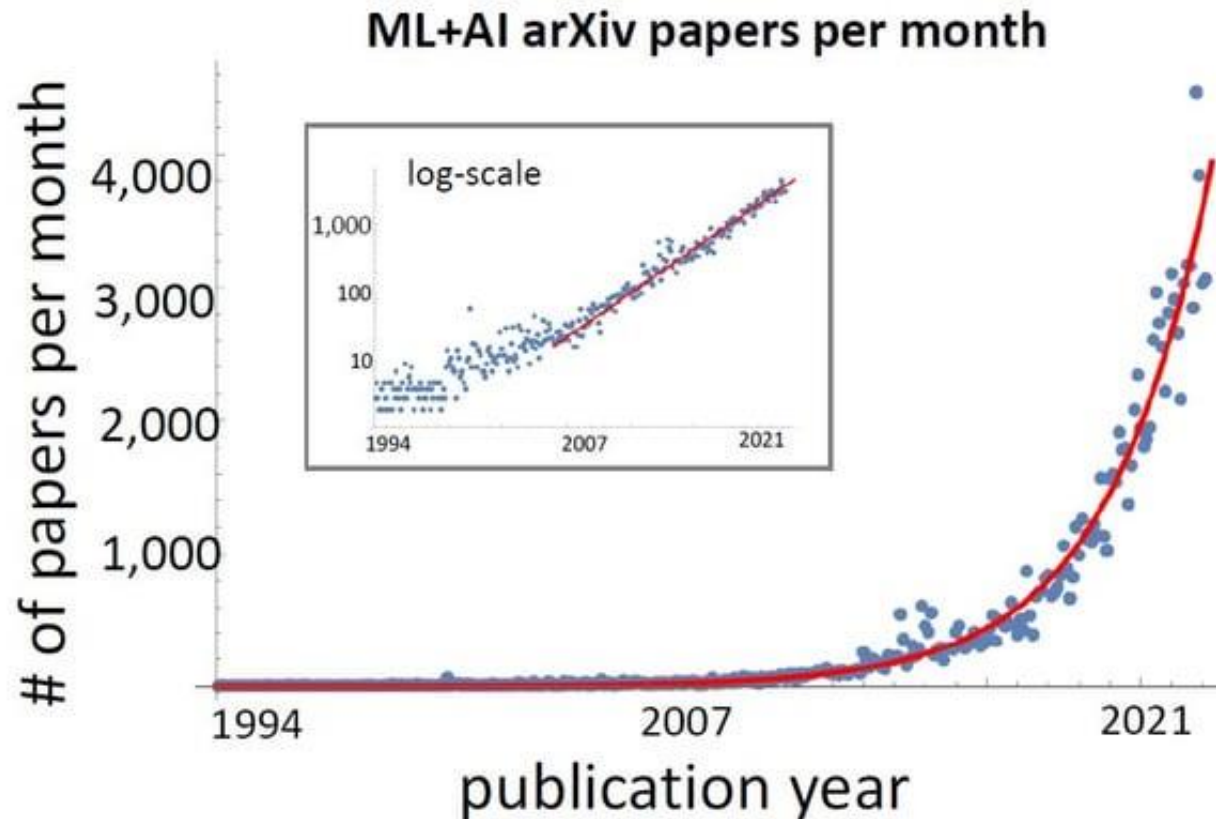

Course Logistics

Class Logistics

- Where: G01 Gates (CSE2)
- When: 8:30-9:20 MWF
- Who:
 - Abhishek Gupta (Co-Instructor)
 - Siddhartha Srinivasa (Co-Instructor)
 - Helen Wang (lead TA)
 - Rohan Baijal (TA)
 - Sidharth Talia (TA)
 - Christopher Tan (TA)



Who is Abhishek?



- New(ish) assistant professor in CSE
- Grew up in Oregon/India, 10 years in Berkeley
- Undergrad Berkeley, Ph.D. Berkeley, Postdoc MIT.
- Interests: RL/robotics/optimization and control/robustness and generalization
- Outside of work: Tennis/soccer/running/sketching/dog enthusiast

Who is Sidd?



- Professor @ CSE
- Research interests: motion planning, adaptive control, human-robot interaction
- Non-research interests: tennis, cooking
- Fun fact: I have an unreasonable love for Cheese Danish!



Who's Helen?

- Ph.D. Student working w/ Sidd & Dieter
- Grew up in Toronto, Canada
- Research Interests: Interpretable Evaluation, Imitation Learning
- Non-research Interests: Taking walks, food ranging
- Fun fact: I have a mental map of all the best food & boba places around Seattle

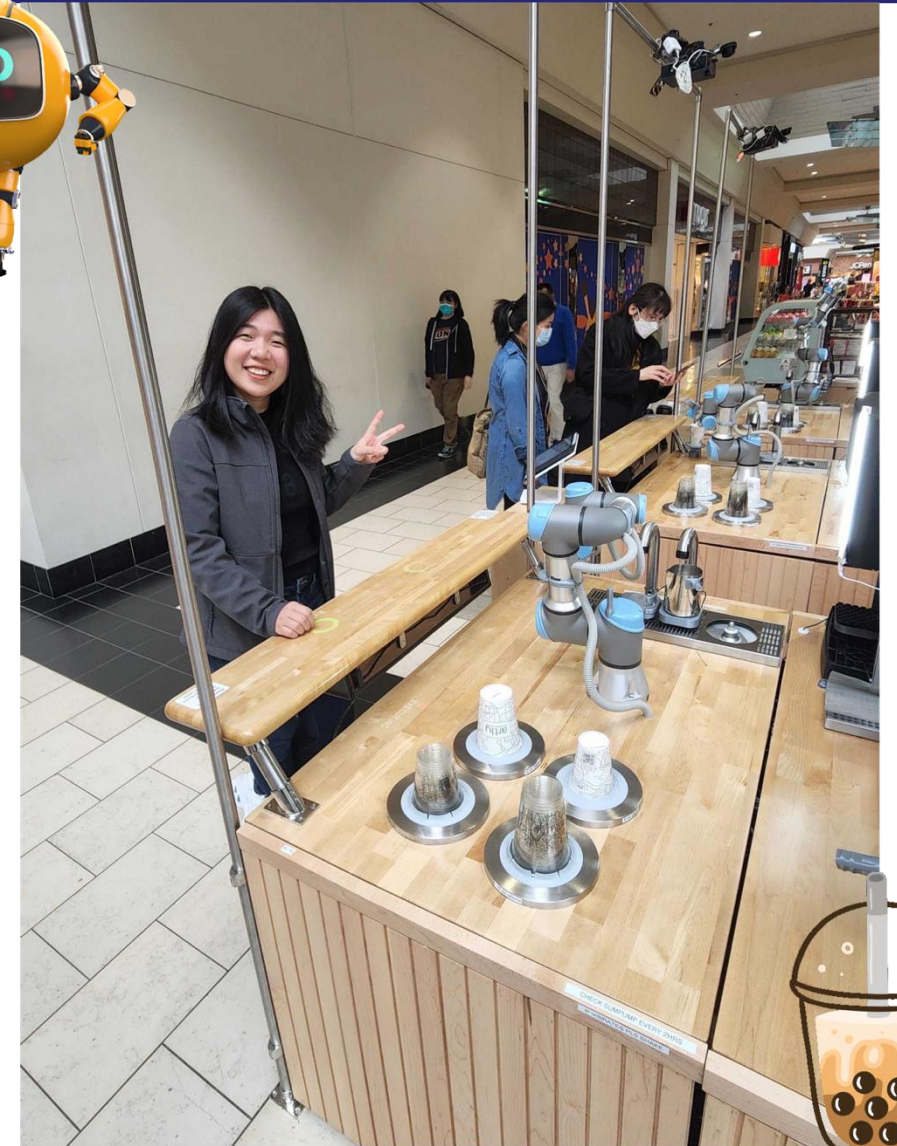
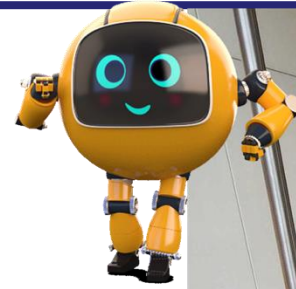

My two favorite things in one image: robots and bbt :)

Who's Sid Talia(Talia)?



- Ph.D. student since 2022 advised by Prof. Sidd. Srinivasa
- Research interests: Robot systems, Planning and control
- Non-research interests: cooking, car-spotting.
- Fun fact: If you can't find me at my desk, it is likely because I am stuffing myself with free food in some grad kitchen.

Who's Rohan?

- Ph.D. Student with Byron
- Grew up in India, undergrad in Kanpur
- Research Interests: Online Learning, Long Horizon Autonomy
- Non-research Interests: Playing music, hiking, skiing, learning new sports and instruments

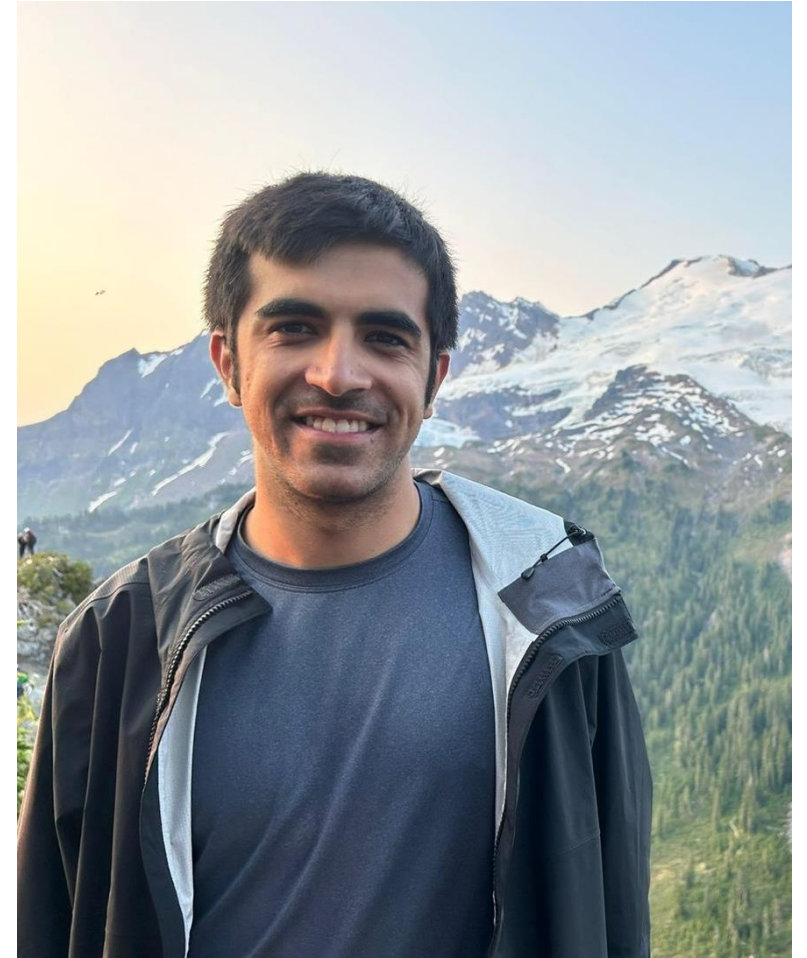

Grading Rubric

- **Team Programming projects** and writeups (4), graded on an SN scale [10% of the grade each x 4 = 40% of grade]
 - N will come with TA feedback and guidance; revise and resubmit
 - Due dates are paced throughout the quarter
- **Team Seeded Paper Discussions** [10% of grade]
 - Present new paper ideas and provide 2-3 paragraphs of commentary
- **Individual Quizzes** (30 minutes in class) [40% of grade]
 - Test out your conceptual knowledge in multiple-choice question format
- **Team Final Project** [10% of grade]
 - Combine projects for a full stack racecar solution

Grading - MuSHR Programming Projects

- Learn to program the MuSHR car with Python and the Robot Operating System!
- **Teams of 4/5**
- Autograding for all homeworks! (no hidden tests)



Project 1: Introduction

Get acquainted with the ROS ecosystem and the MuSHR virtual machine.

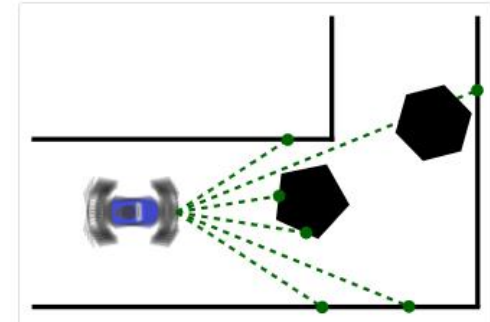

Project 2: Localization

Localize your car by implementing the particle filtering algorithm.

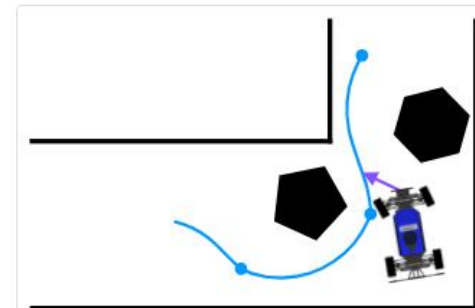

Project 3: Control

Implement feedback controllers to follow pre-planned trajectories.

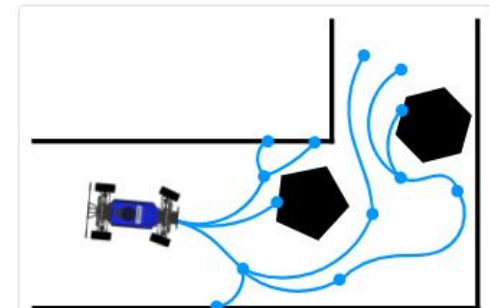

Project 4: Planning

Implement Lazy A* and postprocessing to plan new trajectories.

Grading – Seeded Paper Discussion

- Key idea: we will seed ideas with a “seed paper”. Your job is to build from the seed paper and suggest a new paper-level idea, and defend it to the class.
 - **Motivation:** Tell us why we should care about your idea
 - **Technical Idea:** Tell us your idea
 - **Experiments:** Tell us how you would validate your idea and what experiments you’d run
 - **Related Work:** Tell us how your idea will position itself in the literature
- Everyone **not** presenting posts constructive commentaries about the idea on EdStem!

Grading – Quizzes

- Multiple choice questions about each module – state estimation, control, planning, learning
- Mix of questions to test your conceptual and problem solving understanding.
- 30 minutes in class, no laptops/phones – old school!



Grading – Final Project

- Combine all 4 previous projects into a final racecar that can complete a track
- Special prizes for teams with top 3 fastest times (no grades)

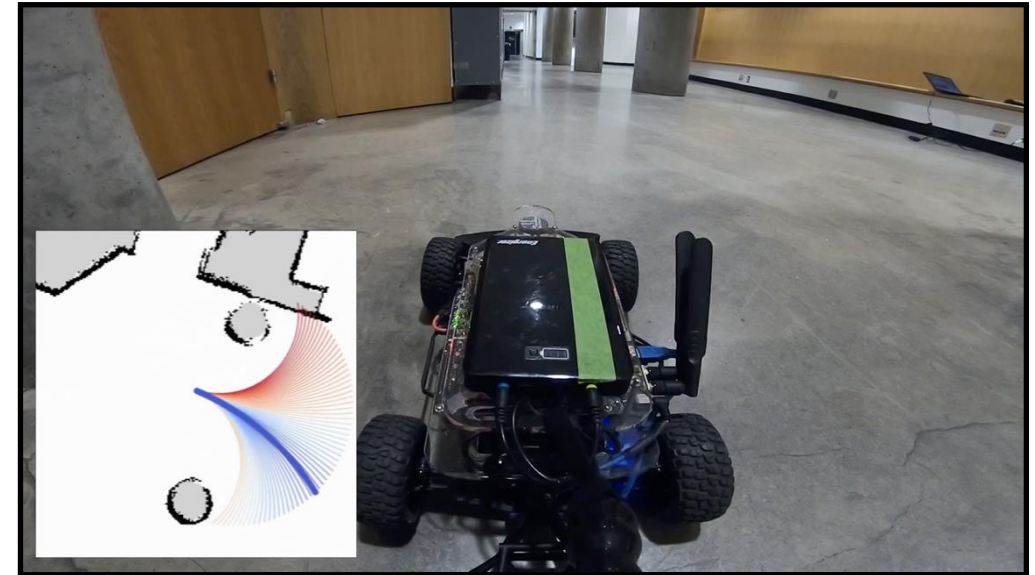

Please come to class and participate!



(Approximate) Course Outline

Week	Lectures	Assignments
Week 1	Introduction (AG)	Project 1: Introduction to ROS, Python, Simulation, RACECAR
Weeks 2-4	State Estimation + SLAM (AG)	Project 2: Localize robot on a known map with particle filters
Weeks 5-6	Control (SS)	Project 3: Feedback control to track paths while avoiding obstacles
Weeks 7-8	Planning (SS)	Project 4: Plan a complex maneuver around obstacles at high speeds
Weeks 9-10	Learning for Control (AG)	Final project

Week 11, Final project: Combine modules to navigate around a track and solve tasks!

Teams

- Teams will be assigned by the staff
- Complete the Knowledge Survey (on website) by Tuesday 3/31 EOD for us to assign teams
- **Same team** for the 4 projects and final project:
 - If there are any issues, let us know and we will help make changes.
- Please let us know if you'd like to change teams early!

Ensuring Fair Participation

- We will try and enforce equity in terms of effort contributed to group projects
 - Every student fills out a self and peer evaluation for every project. Factored into grades



MuSHR Programming Projects - Tips

Each assignment has two parts:

1. Simulation - easier
2. Real-robot execution - 10X harder

Budget *contiguous* chunks of time *early* for the robot

Work as a team! Divide and conquer



Project 1: Introduction

Get acquainted with the ROS ecosystem and the MuSHR virtual machine.

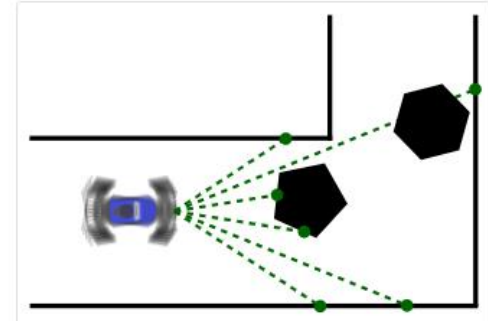

Project 2: Localization

Localize your car by implementing the particle filtering algorithm.

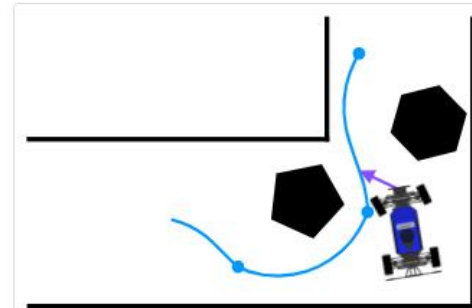

Project 3: Control

Implement feedback controllers to follow pre-planned trajectories.

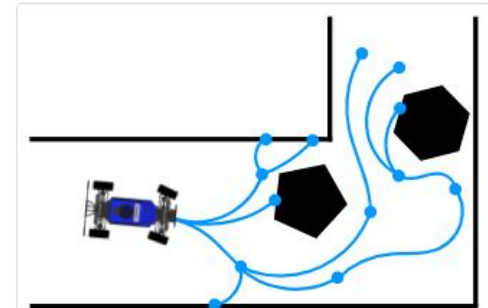

Project 4: Planning

Implement Lazy A* and postprocessing to plan new trajectories.

Lab / Office hours

- Lectures - MWF 8:30 - 9:20AM, Gates G01
- Conceptual office hours:
 - Abhishek (CSE2 215): Monday 4-5pm, by appointment otherwise
 - Helen (zoom): Tuesday 11am-12pm
 - Rohan : Wednesday 11:30am-12:30pm
- Lab Office Hours (CSE1 002):
 - Thursday 1:30-3:30 (Everyone)
 - Tuesday 1:30-2:30 (Sid Talia)
 - Monday 10:30-11:30 (Christopher)
 - Welcome to come in and use the resources unguided at other times!
- Ask questions asynchronously through EdStem

MuSHR Lab CSE (Allen) 002

- We have a separate lab for teams to work on robots
 - CSE1 (Allen) 002 (Basement)
 - Card-key operated (let us know if your keycard doesn't work)
- Each team gets a dedicated workstation with Ubuntu + Python + ROS pre-installed.
- Each team gets 1 dedicated RACECAR (same for duration of class)
 - We will help fix/replace cars that get damaged.

RACECAR Logistics

- Please treat cars with respect
- Do not change the passwords on the cars
- Each team maintains their own batteries - don't use others
- Keep your space clean
- Cars stay in Allen 002 – no taking them home!
- We will announce special OH for picking up your cars

Course Logistics - Integrity

- Late policy
 - No late days allowed, unless there are exceptional circumstances
- Academic Honesty Policy
 - It's fine to use a source for generic algorithms (with attribution), but it is not allowed to copy solutions to the problems. Additionally, **students may not post their code online**. If we determine that a student posted their code online, they will get an automatic 50% reduction on the entire assignment and if they copy code for the problems from another student or from online, they will get an automatic 0% for the entire assignment (and possibly reported to the college).
- Don't just ChatGPT the whole solution, you're not really going to get what you're looking for from the class!

Let's take a bit of a historical detour

What is a robot?

- First definitions:
 - Karel Capek → robots were biological beings performing unpleasant labor.

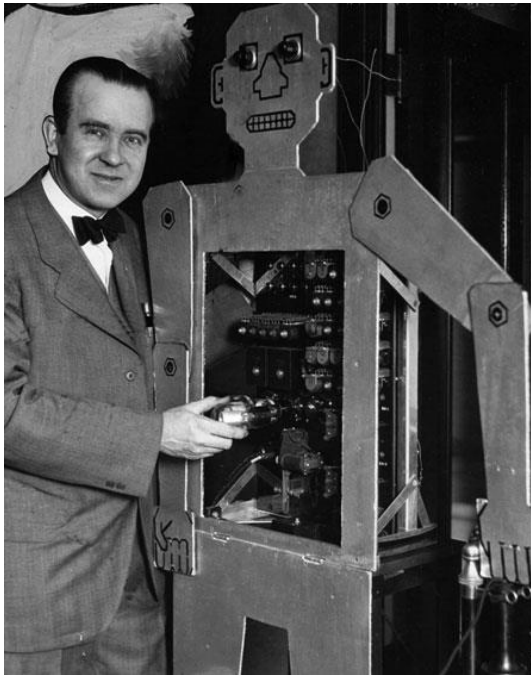

Herbert Televox (1927)



Eric (1928)



Unimate (1961)

The first wave of robots



Shakey

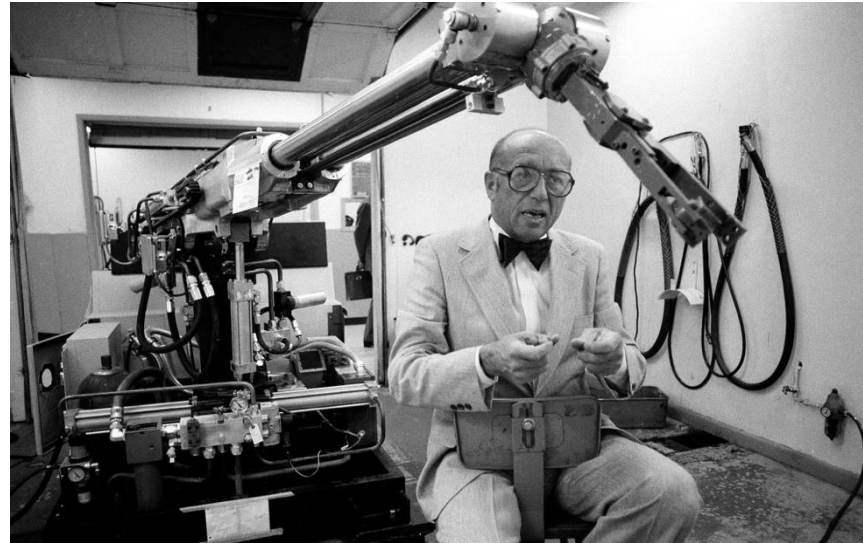

Engelberger
(Unimate ++)

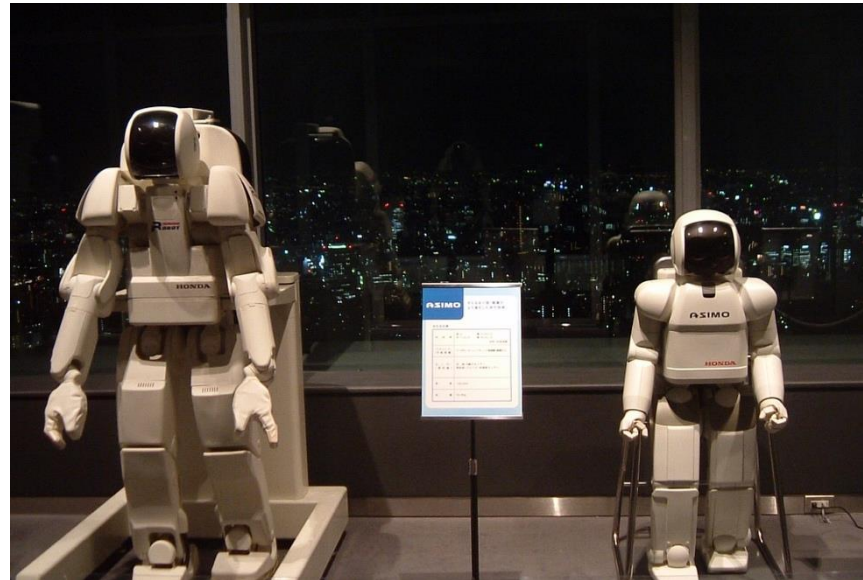

Honda P series

The second wave of robots

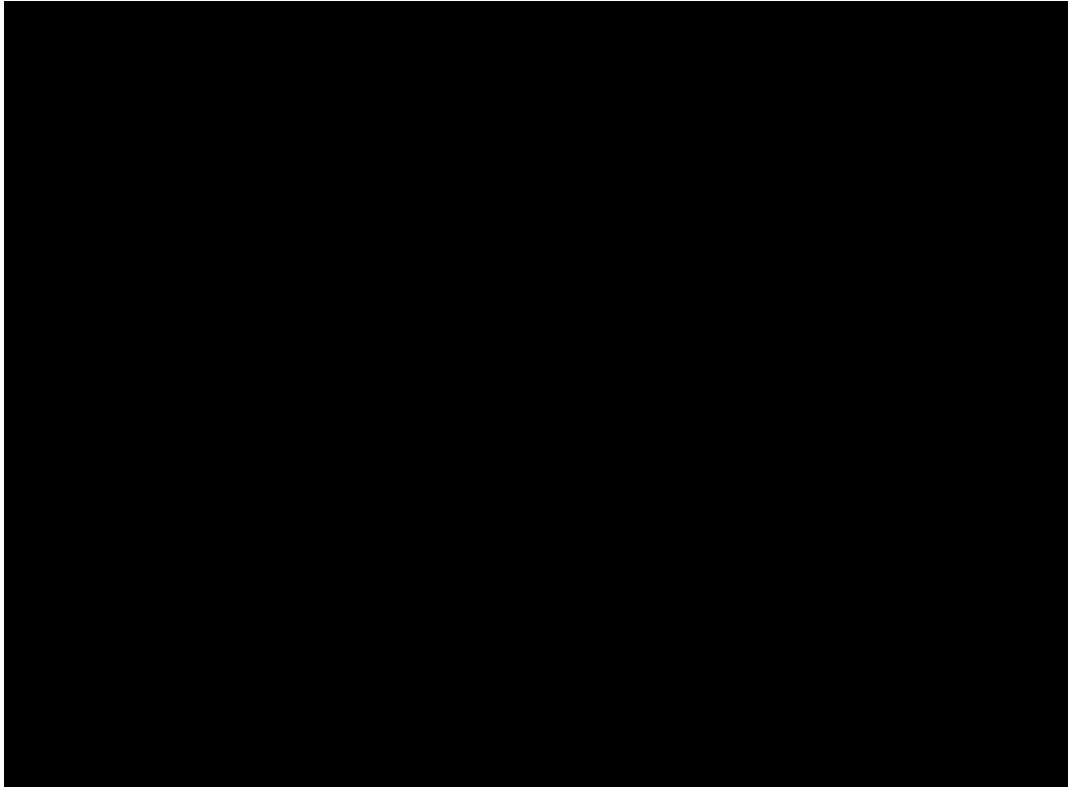

DARPA Grand Challenge



PR1
Robot

Robots Today



Everyday Robotics - Google



Atlas – Boston Dynamics

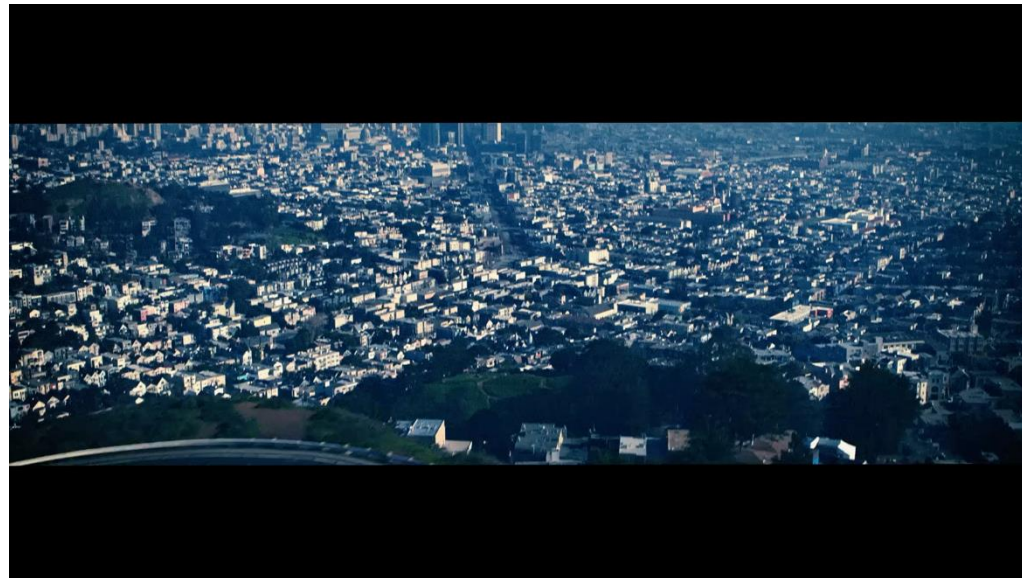

Waymo – self driving cars

Robotics Spans Applications and Industries

- Applicable in a variety of industries and spaces:
 - Industry:
 - Industrial manufacturing
 - Warehouse navigation
 - Outdoor navigation/locomotion:
 - Legged locomotion
 - Outdoor navigation
 - Last mile delivery
 - Self driving cars
 - Home and office manipulation
 - Mobile manipulation
 - Dexterous manipulation

Industrial Robotics

Industrial Robotics Today



Robots in Warehouses (Kiva@Amazon)



Navigation

DARPA Urban Challenge 2007



Self-Driving Cars



High-Speed Autonomous Drifting



Locomotion

Boston Dynamics BigDog (2008)



Humanoid Parkour

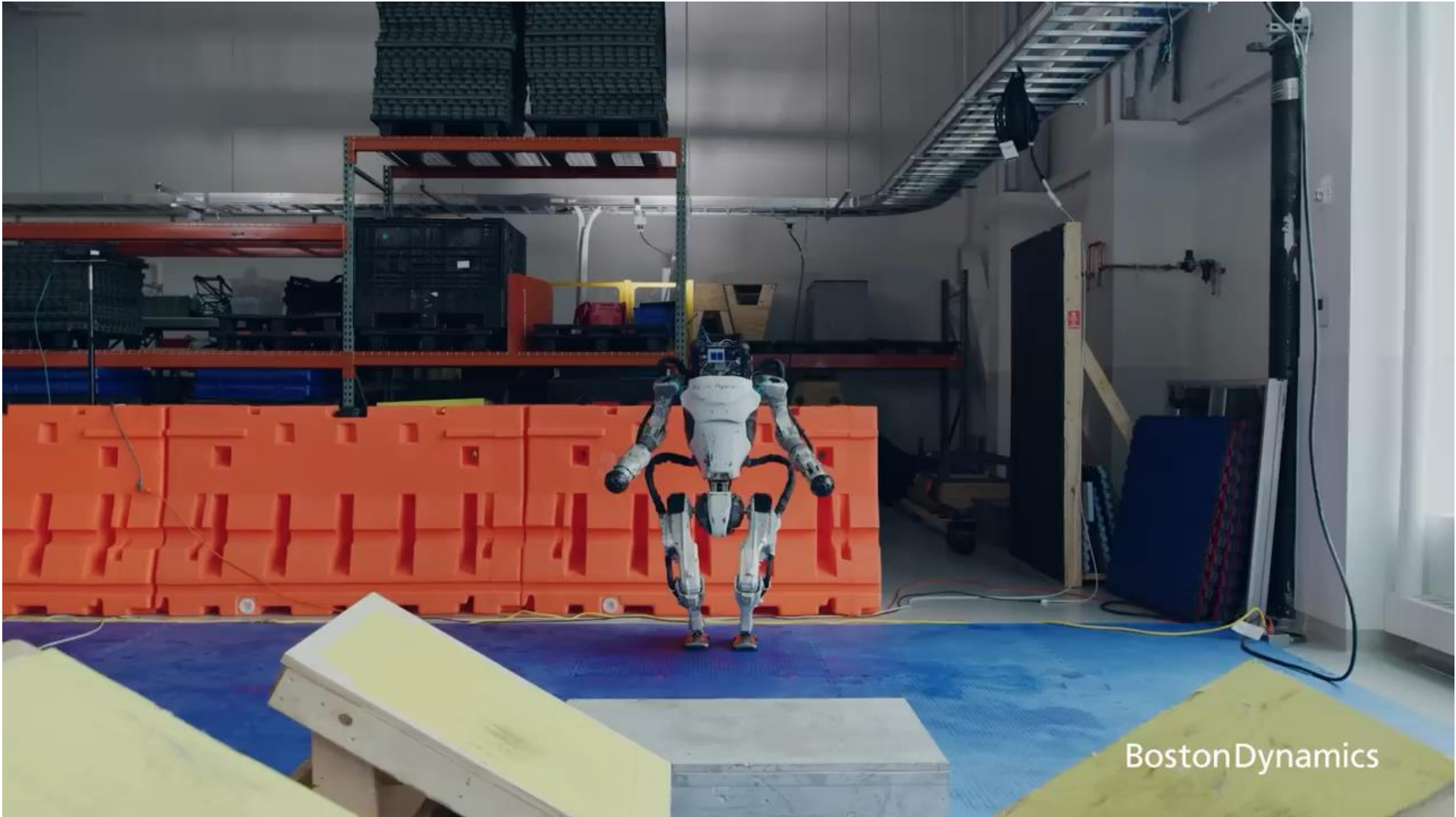

RL-Based Locomotion

ETHZ

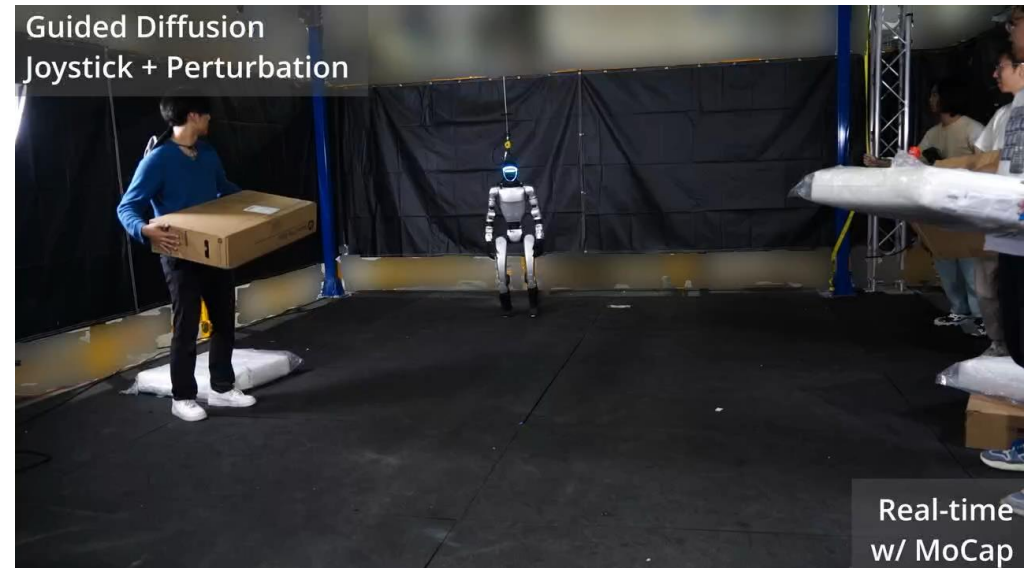
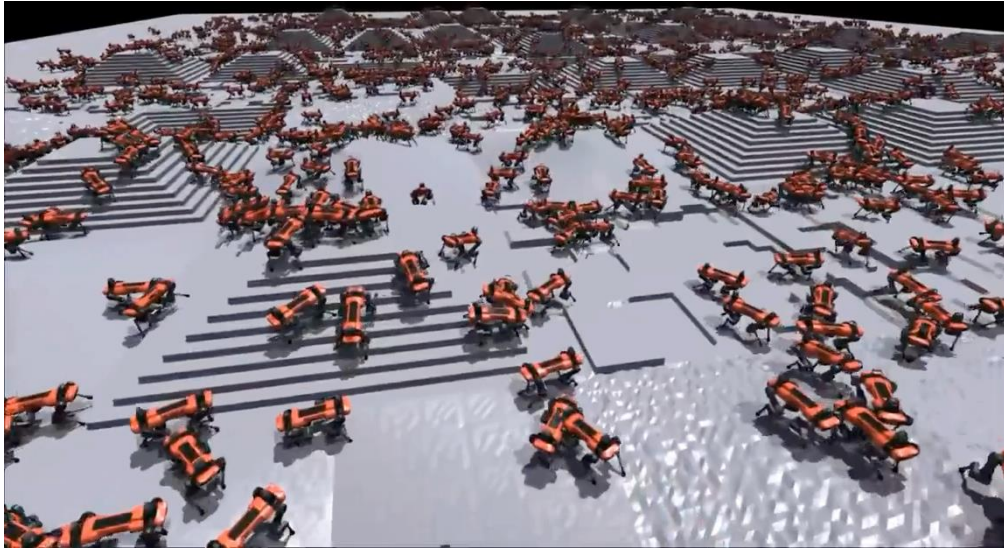

Manipulation

Dexterous Manipulation (circa 2016)



Mobile Manipulation



Dexterous Manipulation with Foundation Models



Why should we care about robotics?

Societal Impact



\$\$

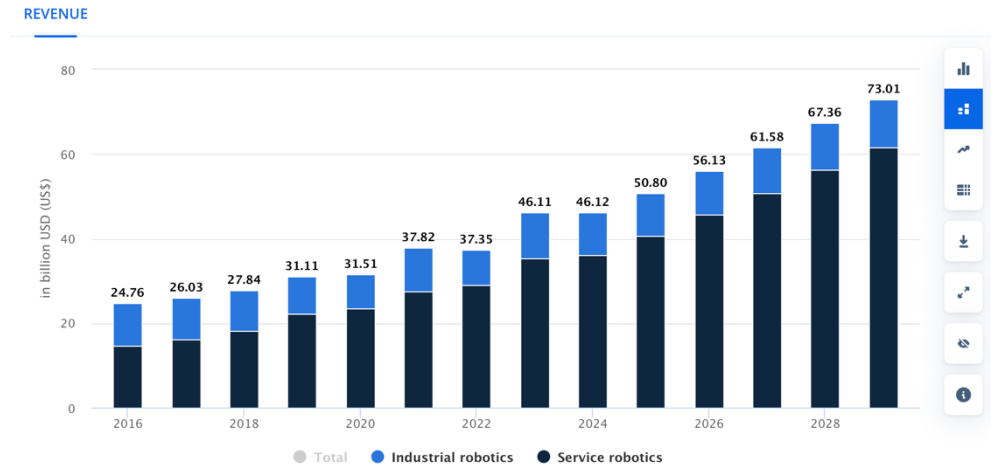

Not solved yet!



Ok this is great – how do we build these robots?

- Need a formal framework for problem definition and a set of tools to solve them

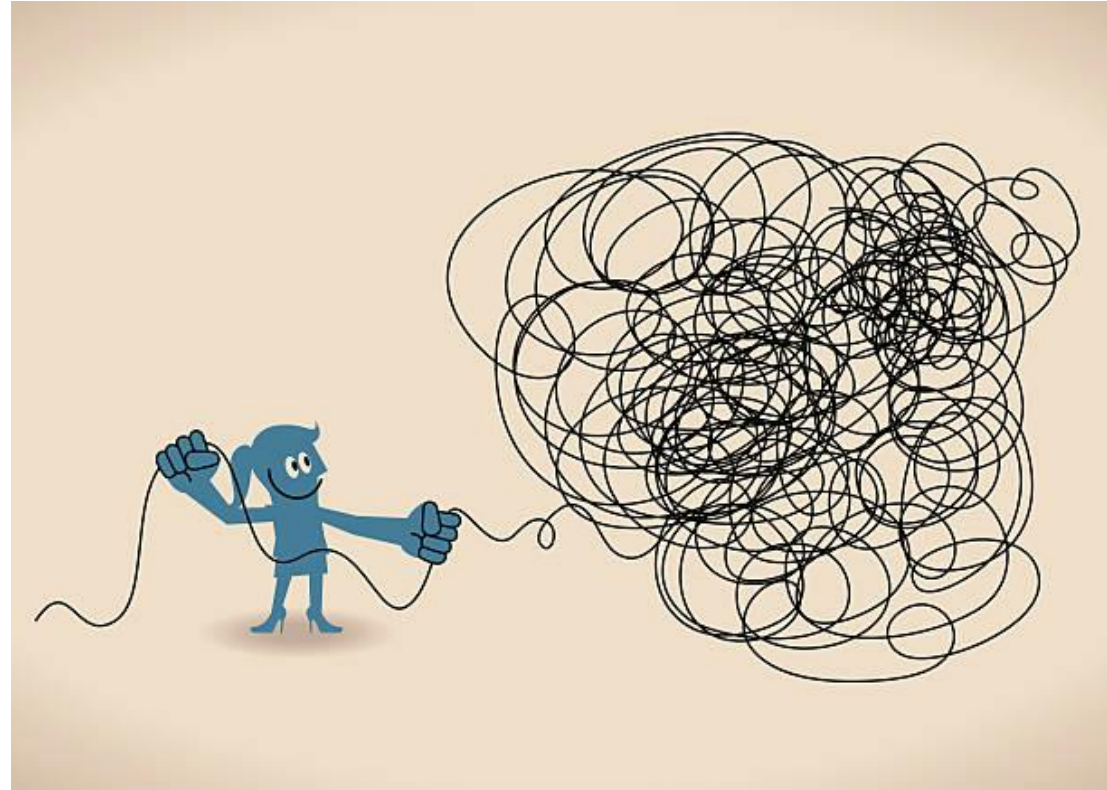

- Sense-plan-act framework with probabilistic inference. More on this next time!