

Introduction

Computer vision is the analysis of digital images by a computer for such applications as:

- **Industrial:** part localization and inspection, robotics
- **Medical:** disease classification, screening, planning
- **Military:** autonomous vehicles, tank recognition
- **Intelligence Gathering:** face recognition, video analysis
- **Security:** video analysis
- **Science:** classification, measurement
- **Document Processing:** text recognition, diagram conversion

Medical Applications

CT image of a patient's abdomen



Visible Man Slice Through Lung

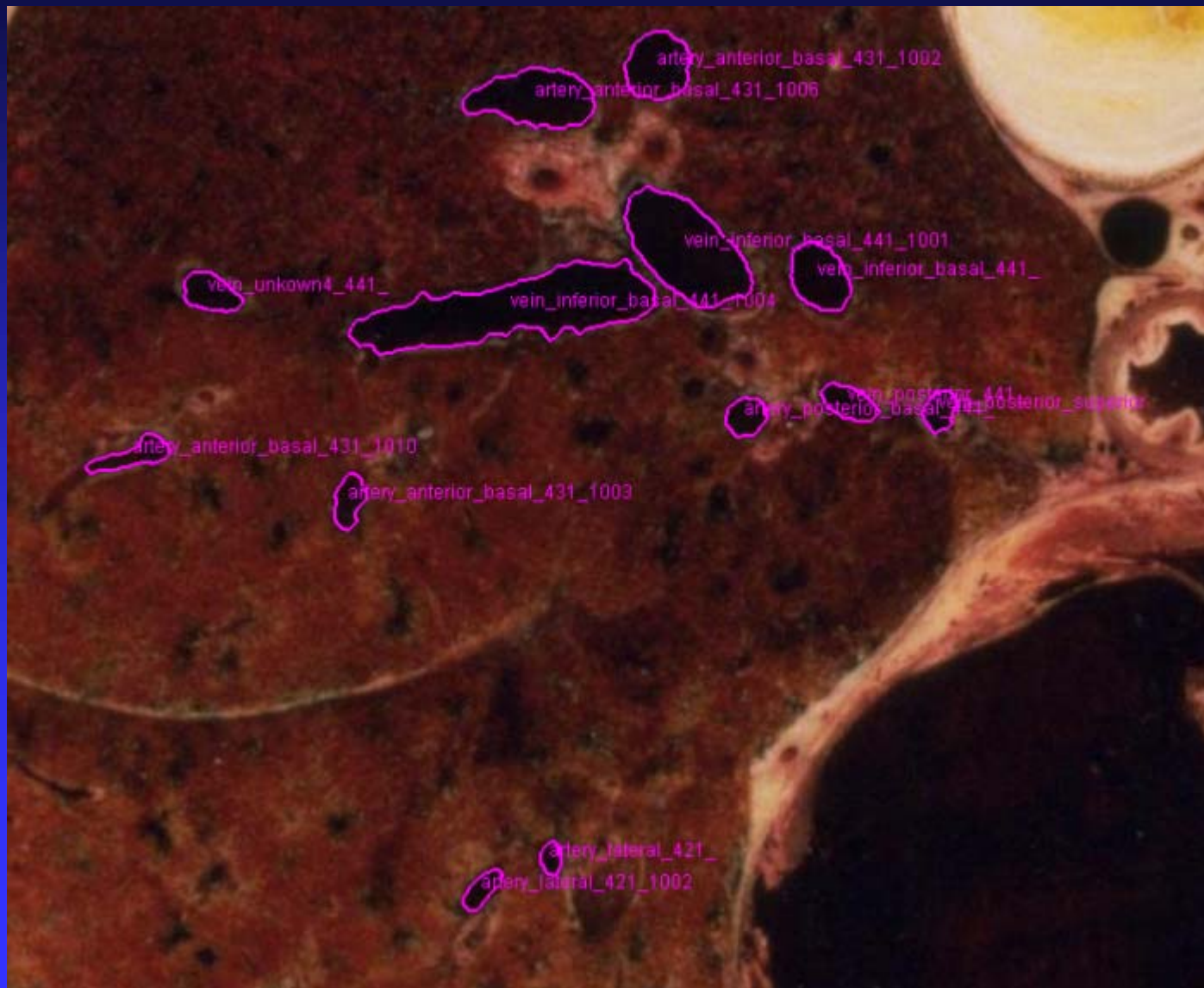

3D Reconstruction of the Blood Vessel Tree

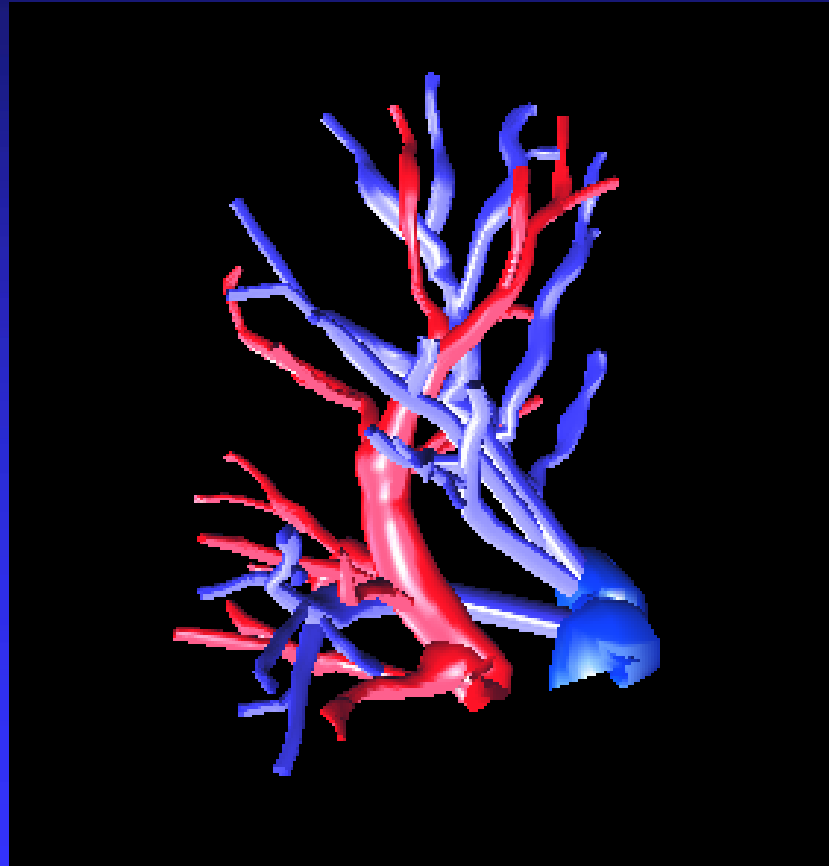

CBIR of Mouse Eye Images for Genetic Studies

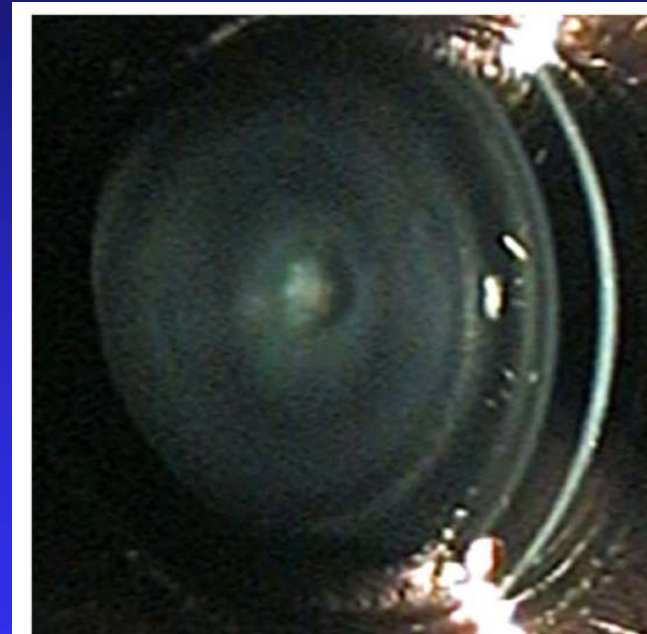
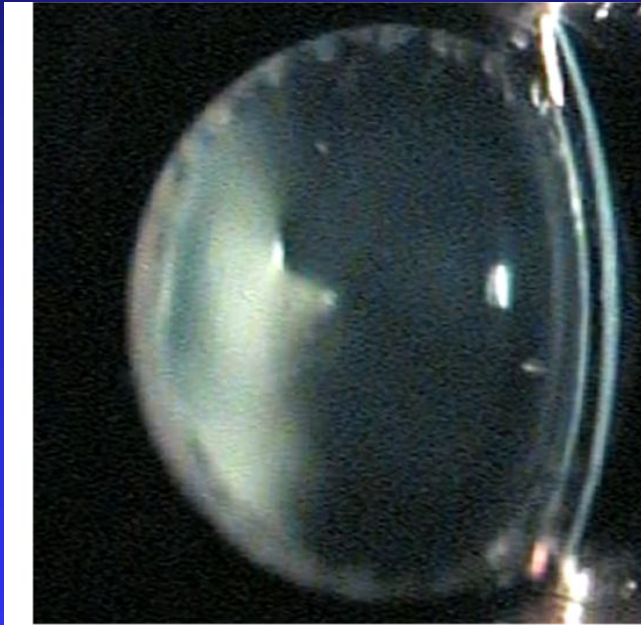

Robotics

- 2D Gray-tone or Color Images

“Mars” rover



- 3D Range Images

What am I?

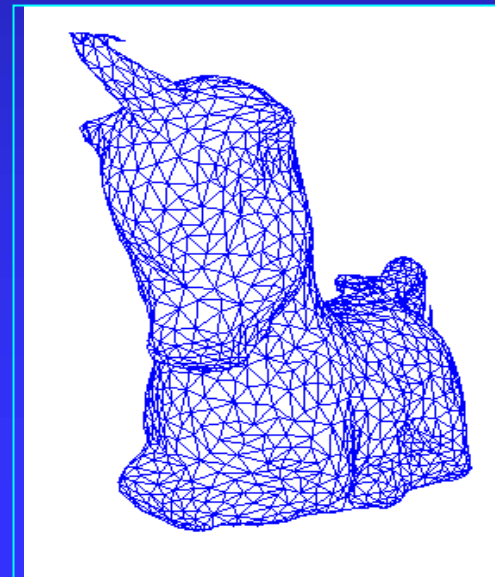

Image Databases:

Images from my Ground-Truth collection.



- Retrieve all images that have trees.
- Retrieve all images that have buildings.
- Retrieve all images that have antelope.

Documents:

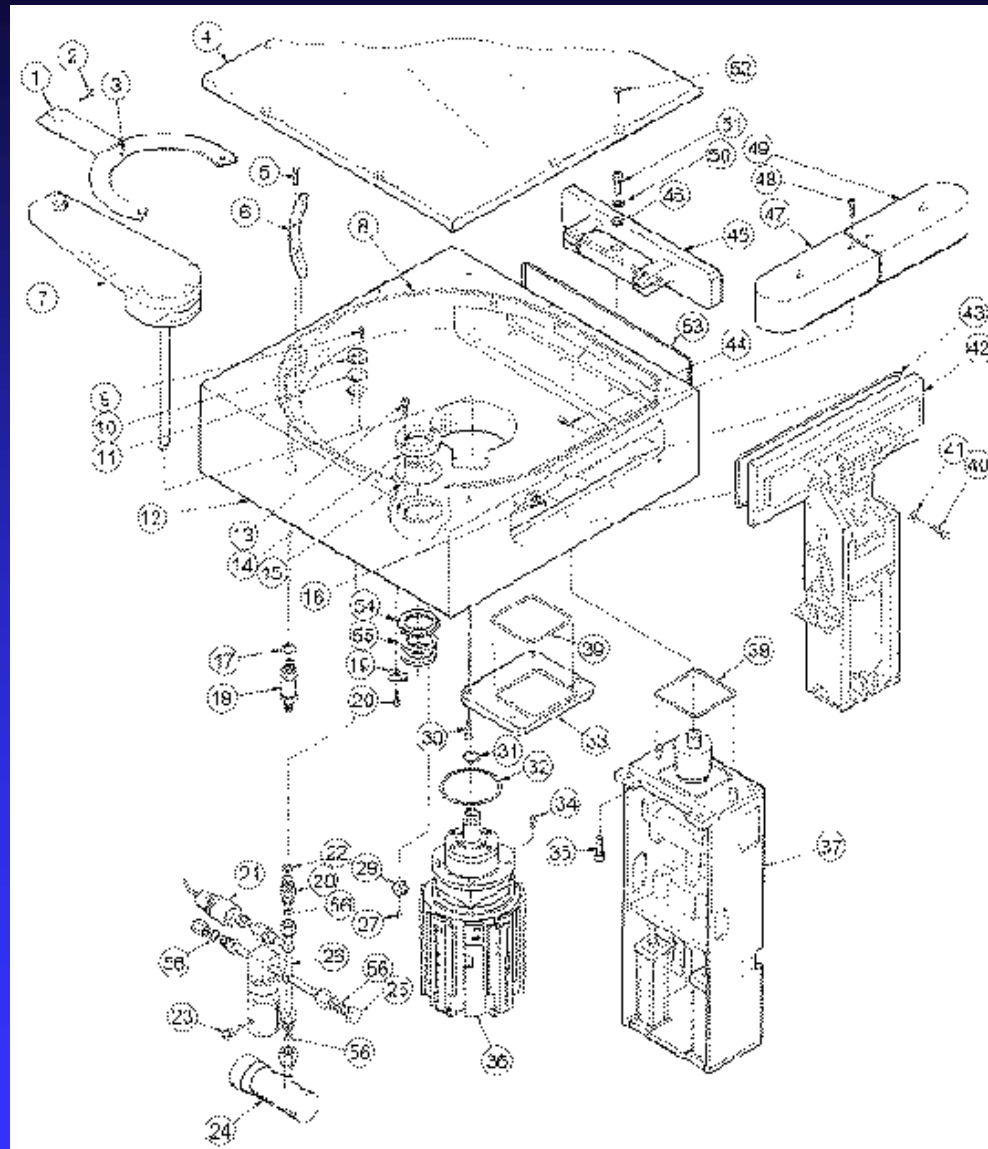

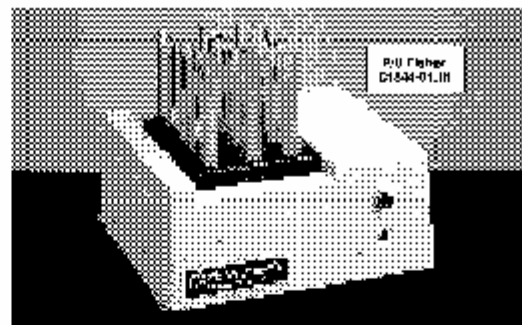

Model 145 Isotemp® Dry Bath Incubator

Holds 1 to 4 heating blocks with choice of 11 well sizes
Maintains every sample in within $\pm 1^{\circ}$ C of temperature

Unique sample wells are shaped so that 2 or more blocks deliver same amount of heat to all parts of the sample tube. No laminar air gradient— neither up nor at the bottom nor top— cold or hot— that may invalidate tests. In tests with drilled cylindrical wells. Sample tubes rest on top of plate. No prevent localized heating. A low cost, stainless-steel temperature on a thick ceramic heat distribution plate in the front of the bath. Plate is 2 1/2" thick (9.5 mm). Dry bath maintains cleaner problems because tubes stay dry.

Ambient to 125°C (255°F) with $\pm 1^{\circ}$ C control. Dial temperature controlled used from 25° to 55° C. Ideal for enzyme reactions, inoculation of sera, Bb studies, cross-matching and blood-typing determinations. (Dimensions: 8.1 x 15.9" x 4" H, 20.5 x 28 x 11 cm). With top cover and plug. Heating blocks sold separately (see lower right).

Electrical Requirements	Cat. No.	Each
200V, 60/50 Hz, 500W/350W approved	11-715-100	419.35
230V, 50/60 Hz, 800W	11-715-102	556.35

Overgo order from manual 37-3
 Pacification Model

Model 147 Isotemp® Dry Bath

Holds single heating block with choice of 11 well sizes

Similar to Model 145, but with 3/8" thick (9.5 mm) plate. Ideal for tests with smaller volumes of enzyme and coagulant assays, Bb studies, and dry incubators. Forward bias-adjusted temperature control between ambient and 85°C (203°F). Observe thermometer panel to use set sample temperature, adjust control through hole in top panel. Maintains set temperature with consistency and uniformity $\pm 1.0^{\circ}$ C.

Supplier with strong nylon case, thermally-protected heater, and indicator amp. See case and plug and instructions. Dimensions: 8.1 x 6.5" W x 3" H, 11.5 x 17 x 8 cm. CSA approved. Heating blocks sold separately (see below).

Electrical Requirements	Cat. No.	Each
120V/50/60 Hz, 120W	11-715-102	223.58

Interchangeable Heating Blocks for Isotemp® Dry Baths

For Models 145 and 147 Dry Baths. Composed of black anodized aluminum alloy. Chemical resistant. Dimensions: 2.1 x 0.9" x 1.2" H (54 x 23 x 30 mm).

The 11-715-123 block provides a safe dry bath of enzyme for warming. Use Spalte of Essen forcoops. Avoids hazardous use of burners and inflammable biologicals, solvents.

The 11-715-120 block is specifically designed to hold twenty 9.5 mm Bertho Diagnostics Placental pregnancy test tubes. This special shallow well block is similar to the other block with 9.5 mm wells, but sample wells are only 1/2" deep (1.0 cm) to meet test requirements. Wells in all other blocks are 1 1/2" deep (3.8 cm).

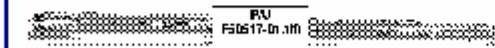

Incu-Block® Partial Immersion Thermometers

For all standard bath, ice blocks and water baths. Critical temperatures (25°, 30°, 37°, 56° C) are marked with arrows. Available with stainless steel, contamination proof Teller® coating. Total length: 1.75 mm. In inches: 35 mm.

Range, °C	Dial, °C	Toler. Coated	Cat. No.	Each
25-57	0-5	Stl.	14-982	45.84
25-57	0-5	Vel.	14-983	46.15

More Thermometers

For more thermometers, including digital types,

see page 952

Customize order.
 Forward to: CMS/Fisher HealthCare, Dept. 200, 1000

Surveillance: Object and Event Recognition in Aerial Videos



Original Video Frame

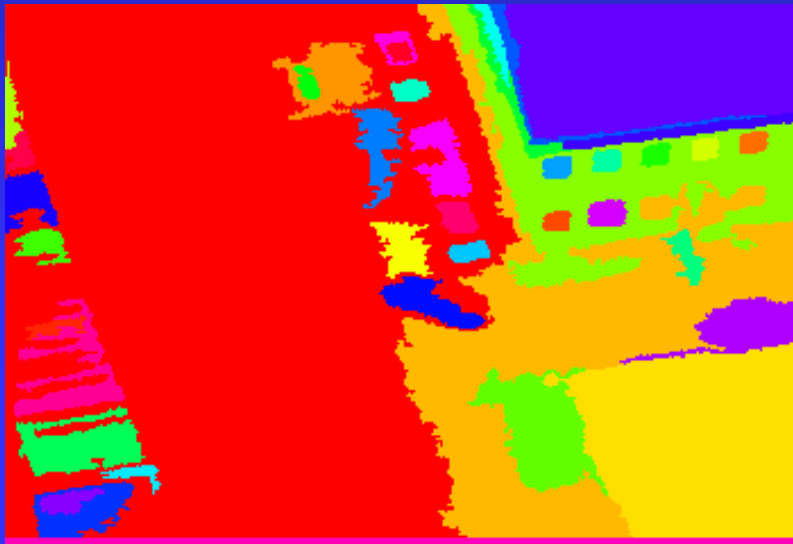

Color Regions



Structure Regions

Digital Image Terminology:

0	0	0	0	1	0	0
0	0	1	1	1	0	0
0	1	95	96	94	93	92
0	0	92	93	93	92	92
0	0	93	93	94	92	93
0	1	92	93	93	93	93
0	0	94	95	95	96	95

pixel (with value 94)

its 3x3 neighborhood

region of medium intensity

resolution (7x7)

- binary image
- gray-scale (or gray-tone) image
- color image
- multi-spectral image
- range image
- labeled image

Goals of Image and Video Analysis

- Segment an image into useful regions
- Perform measurements on certain areas
- Determine what object(s) are in the scene
- Calculate the precise location(s) of objects
- Visually inspect a manufactured object
- Construct a 3D model of the imaged object
- Find “interesting” events in a video

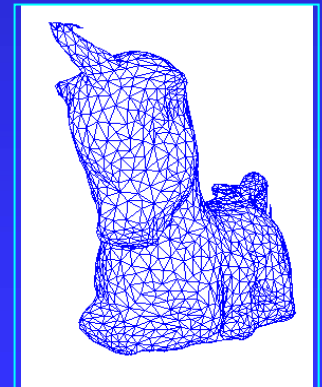
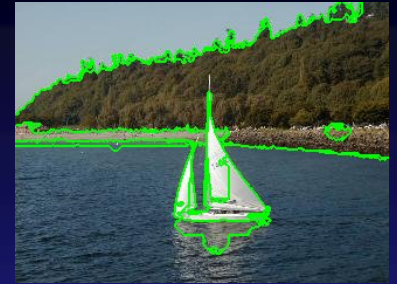

•The Three Stages of Computer Vision

- low-level

image → image

- mid-level

image → features

- high-level

features → analysis

Low-Level

sharpening



blurring

Low-Level



original image

Canny
edge
operator



edge image

Mid-Level (Lines and Curves)



edge image

ORT
line &
circle
extraction



data
structure



circular arcs and line segments 15

Mid-level (Regions)



original color image

K-means
clustering
(followed by
connected
component
analysis)

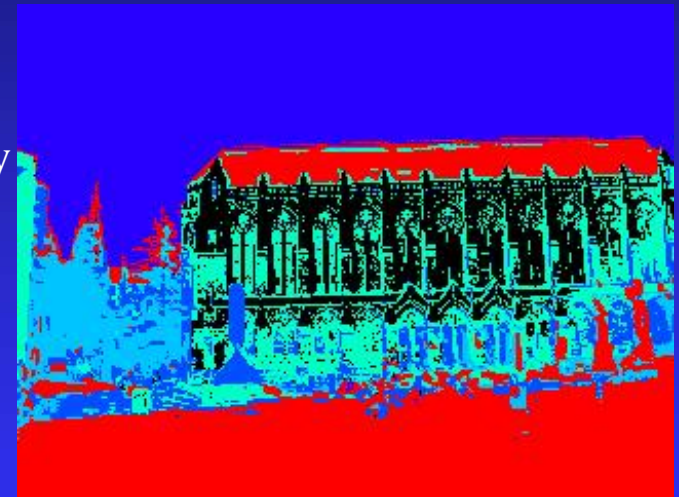

regions of homogeneous color

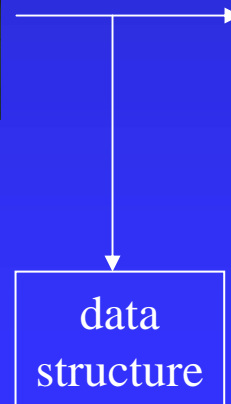

data
structure

Low- to High-Level

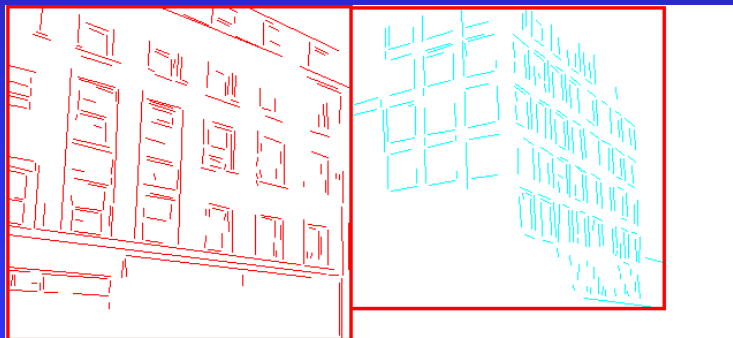

Building Recognition

low-level



edge image

mid-level



high-level

consistent
line clusters

Filtering Operations Use Masks

- Masks operate on a neighborhood of pixels.
- A mask of coefficients is centered on a pixel.
- The mask coefficients are multiplied by the pixel values in its neighborhood and the products are summed.
- The result goes into the corresponding pixel position in the output image.

36	36	36	36	36
36	36	45	45	45
36	45	45	45	54
36	45	54	54	54
45	45	54	54	54

Input Image

1/9	1/9	1/9
1/9	1/9	1/9
1/9	1/9	1/9

3x3 Mask
(mean filter)

**	**	**	**	**
**	39	**	**	**
**	**	**	**	**
**	**	**	**	**
**	**	**	**	**

Output Image

Comparison: salt and pepper noise

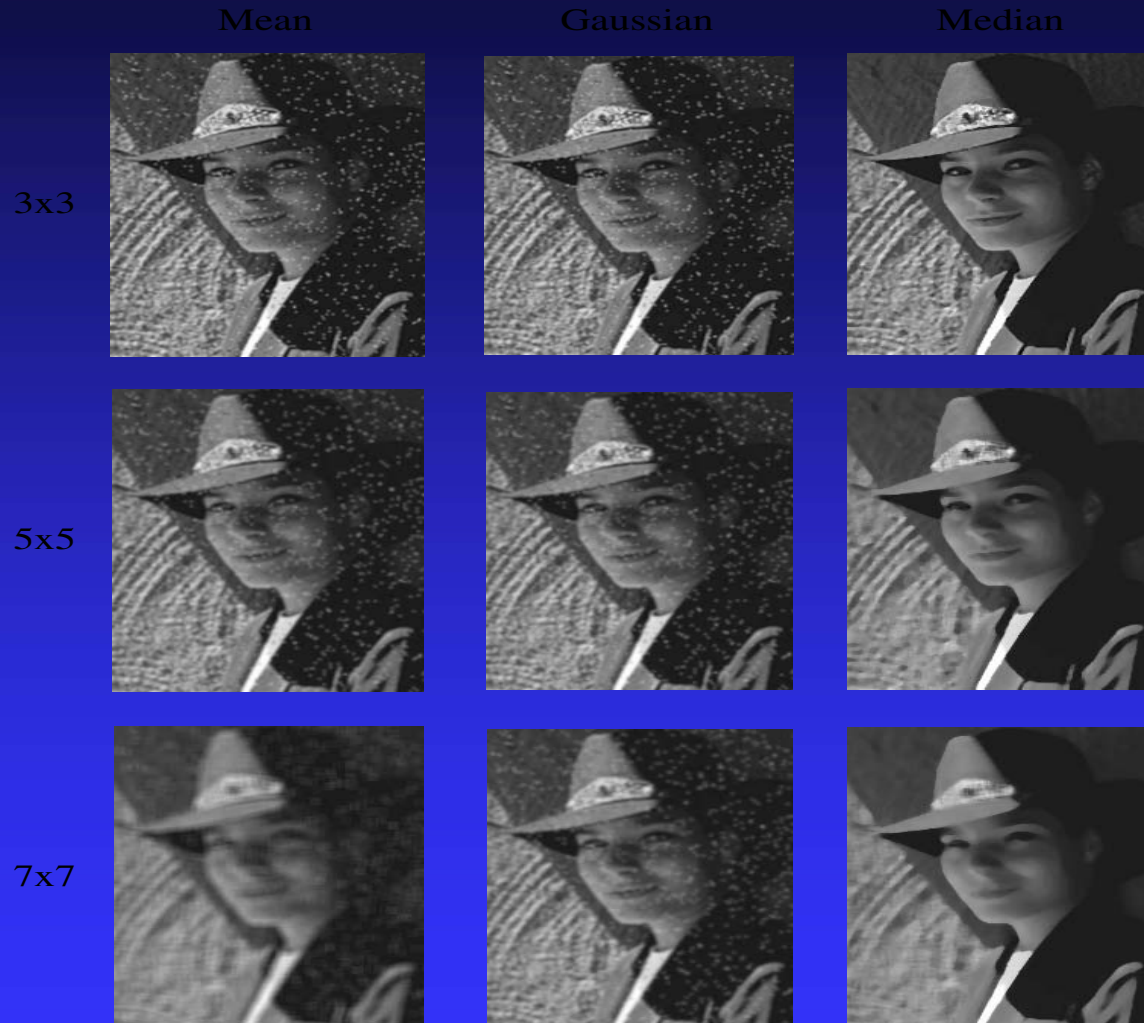

Comparison: Gaussian noise



Lines and Arcs

Segmentation

In some image sets, lines, curves, and circular arcs are more useful than regions or helpful in addition to regions.

Lines and arcs are often used in

- object recognition
- stereo matching
- document analysis

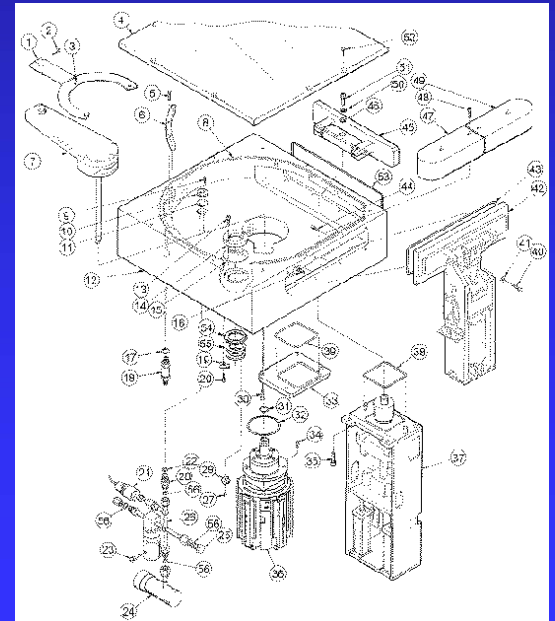

Edge Detection

Basic idea: look for a neighborhood with strong signs of change.

Problems:

- neighborhood size
- how to detect change

81	82	26	24
82	33	25	25
81	82	26	24

Differential Operators

Differential operators

- attempt to approximate the gradient at a pixel via masks
- threshold the gradient to select the edge pixels

Example: Sobel Operator

$$S_x = \begin{bmatrix} -1 & 0 & 1 \\ -2 & 0 & 2 \\ -1 & 0 & 1 \end{bmatrix}$$

$$S_y = \begin{bmatrix} 1 & 2 & 1 \\ 0 & 0 & 0 \\ -1 & -2 & -1 \end{bmatrix}$$

On a pixel of the image I

- let g_x be the response to S_x
- let g_y be the response to S_y

Then the gradient is

$$\nabla I = [g_x \ g_y]^T$$

And $g = (g_x^2 + g_y^2)^{1/2}$ is the gradient magnitude.

$\theta = \text{atan2}(g_y, g_x)$ is the gradient direction.

Sobel Operator on the Blocks Image

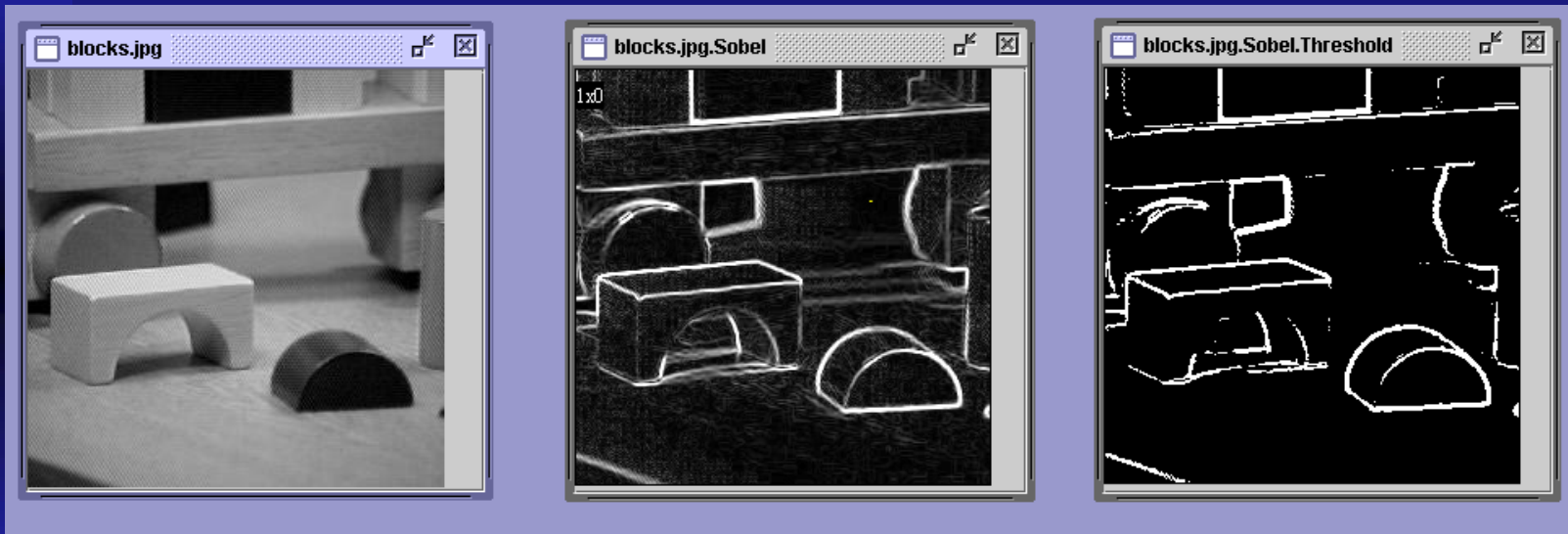

original image

gradient
magnitude

thresholded
gradient
magnitude

Common Masks for Computing Gradient

■ Sobel:

$$\begin{bmatrix} -1 & 0 & 1 \\ -2 & 0 & 2 \\ -1 & 0 & 1 \end{bmatrix}$$

$$\begin{bmatrix} 1 & 2 & 1 \\ 0 & 0 & 0 \\ -1 & -2 & -1 \end{bmatrix}$$

■ Prewitt:

$$\begin{bmatrix} -1 & 0 & 1 \\ -1 & 0 & 1 \\ -1 & 0 & 1 \end{bmatrix}$$

$$\begin{bmatrix} 1 & 1 & 1 \\ 0 & 0 & 0 \\ -1 & -1 & -1 \end{bmatrix}$$

■ Roberts

$$\begin{bmatrix} 0 & 1 \\ -1 & 0 \end{bmatrix}$$

$$\begin{bmatrix} 1 & 0 \\ 0 & -1 \end{bmatrix}$$

Sx

Sy

Canny Edge Detector

- Smooth the image with a Gaussian filter with spread σ .
- Compute gradient magnitude and direction at each pixel of the smoothed image.
- Zero out any pixel response \leq the two neighboring pixels on either side of it, along the direction of the gradient.
- Track high-magnitude contours.
- Keep only pixels along these contours, so weak little segments go away.

Canny Examples

Canny $\sigma=1$

Canny $\sigma=4$



Canny $\sigma=1$

Roberts 2X2

Canny on Kidney Image

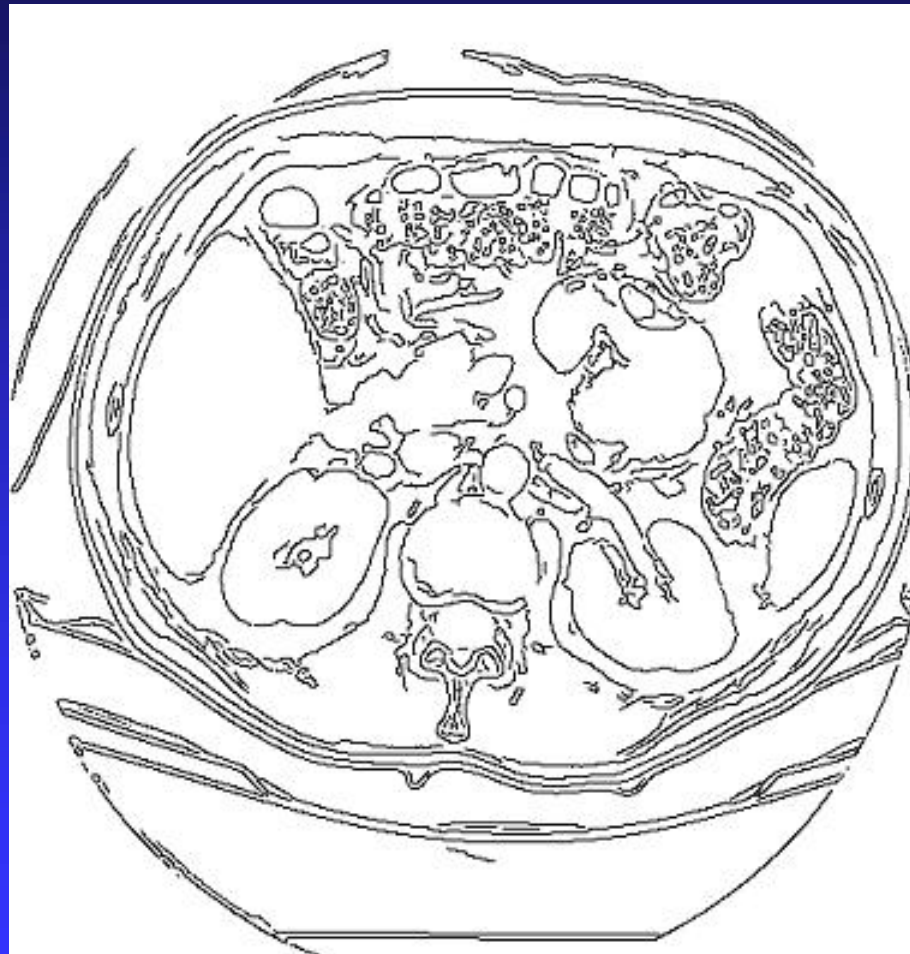

Canny on the Blocks image



Canny Characteristics

- The Canny operator gives single-pixel-wide images with good continuation between adjacent pixels
- It is the most widely used edge operator today; no one has done better since it came out in the late 80s. Many implementations are available.
- It is very sensitive to its parameters, which need to be adjusted for different application domains.

Segmentation into Regions

- Instead of looking for 1D features like lines and curves, some processes look for regions.
-
- The regions must be homogeneous in some attribute such as gray-tone, color, texture,...
- Although “region-growing” was popular in the past, clustering the pixels into subsets has become the best methodology for finding regions.