

Introduction

Why memory subsystem design is important

- CPU speeds increase 25%-30% per year
- DRAM speeds increase 2%-11% per year

Memory Hierarchy

Levels of memory with different sizes & speeds

- close to the CPU: small, fast access
- close to memory: large, slow access

Memory hierarchies improve performance

1. **caches**: demand-driven storage
 2. principal of **locality of reference**
 - **temporal**: a referenced word will be referenced again soon
 - **spatial**: words near a reference word will be referenced soon
 3. speed/size trade-off in technology
- ⇒ fast access for most references

First Cache: IBM 360/85 in the late '60s

Cache Organization

Block:

- # bytes associated with 1 tag
- usually the # bytes transferred on a memory request

Set: the blocks that can be accessed with the same index bits

Associativity: the number of blocks in a set

- direct mapped
- set associative
- fully associative

Size: # bytes of **data**

How do you calculate this?

Logical Diagram of a Cache

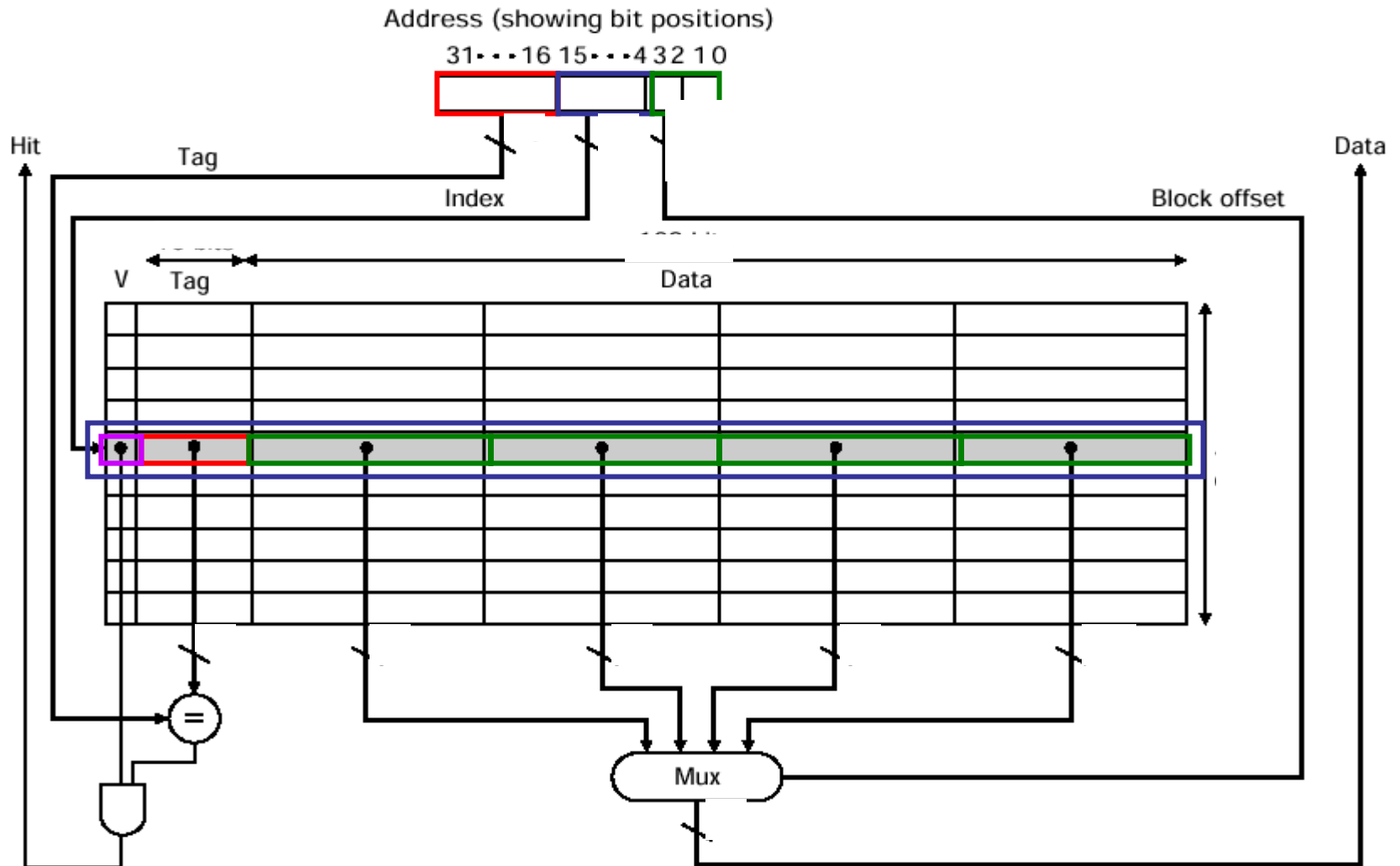

Logical Diagram of a Set-associative Cache

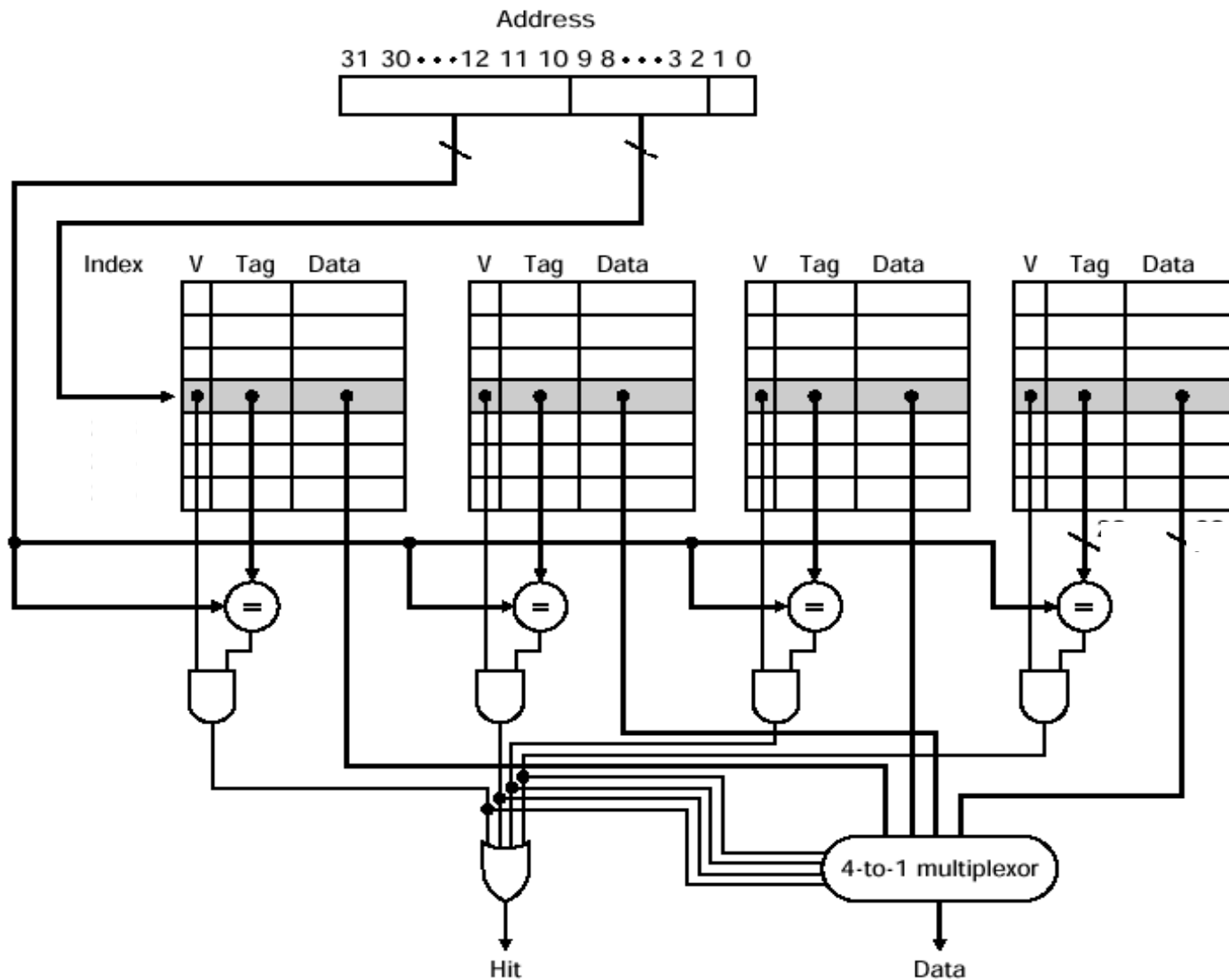

Accessing a Cache

General formulas

- number of index bits = $\log_2(\text{cache size} / \text{block size})$
(for a direct mapped cache)
- number of index bits = $\log_2(\text{cache size} / (\text{block size} * \text{associativity}))$
(for a set-associative cache)

Design Tradeoffs

Cache size

the bigger the cache,

+ the higher the hit ratio

- the longer the access time

Design Tradeoffs

Block size

the bigger the block,

- + the better the spatial locality
- + less block transfer overhead/block
- + less tag overhead/entry (assuming same number of entries)
- might not access all the bytes in the block

Design Tradeoffs

Associativity

the larger the associativity,

+ the higher the hit ratio

- the larger the hardware cost (comparator/set)

- the longer the hit time (a larger MUX)

- need hardware that decides which block to replace

- increase in tag bits (if same size cache)

Associativity is more important for small caches than large
because more memory locations map to the same line
e.g., **TLBs!**

Design Tradeoffs

Memory update policy

- **write-through**
 - performance depends on the # of writes
 - store buffer decreases this
 - check on load misses
 - store compression
- **write-back**
 - performance depends on the # of dirty block replacements but...
 - dirty bit & logic for checking it
 - tag check before the write
 - must flush the cache before I/O
 - optimization: fetch before replace
- both use a merging store buffer

Design Tradeoffs

Cache contents

- **separate** instruction & data caches
 - separate access \Rightarrow double the bandwidth
 - shorter access time
 - different configurations for I & D
- **unified** cache
 - lower miss rate
 - less cache controller hardware

Address Translation

In a nutshell:

- maps a virtual address to a physical address, using the page tables
- number of page offset bits = **page size**

TLB

Translation Lookaside Buffer (TLB):

- cache of most recently translated virtual-to-physical page mappings
- typical configuration
 - 64/128-entry
 - fully associative
 - 4-8 byte blocks
 - .5 -1 cycle hit time
 - low tens of cycles miss penalty
 - misses can be handled in software, software with hardware assists, firmware or hardware
 - write-back
- works because of locality of reference
- much faster than address translation using the page tables

Using a TLB

- (1) Access a TLB using the virtual page number.
- (2) If a **hit**,
 - concatenate the physical page number & the page offset bits to form a physical address;
 - set the **reference bit**;
 - if writing, set the **dirty bit**.
- (3) If a **miss**,
 - get the physical address from the page table;
 - evict a TLB entry & update dirty/reference bits in the page table;
 - update the TLB with the new mapping.

Design Tradeoffs

Virtual or physical addressing

Virtually-addressed caches:

- access with a virtual address (index & tag)
- do address translation on a cache miss
- + faster for hits because no address translation
- + compiler support for better data placement

Design Tradeoffs

Virtually-addressed caches:

- need to flush the cache on a context switch
 - process identification (PID) can avoid this
- synonyms
 - **“the synonym problem”**
 - if 2 processes are sharing data, two (different) virtual addresses map to the same physical address
 - 2 copies of the same data in the cache
 - on a write, only one will be updated; so the other has old data
 - a solution: **page coloring**
 - processes share segments; all shared data have the same offset from the beginning of a segment, i.e., the same low-order bits
 - cache must be \leq the segment size (more precisely, each set of the cache must be \leq the segment size)
 - index taken from segment offset, tag compare on segment #

Design Tradeoffs

Virtual or physical addressing

Physically-addressed caches

- do address translation on every cache access
- access with a physical index & compare with physical tag
- + no cache flushing on a context switch
- + no synonym problem

Design Tradeoffs

Physically-addressed caches

- if a straightforward implementation, hit time increases because must translate the virtual address before access the cache
 - + increase in hit time can be avoided if address translation is done in parallel with the cache access
 - restrict cache size so that cache index bits are in the page offset (virtual & physical bits are the same): **virtually indexed**
 - access the TLB & cache at the same time
 - compare the physical tag from the cache to the physical address (page frame #) from the TLB: **physically tagged**
 - can increase cache size by increasing associativity, but still use page offset bits for the index

Cache Hierarchies

Cache hierarchy

- different caches with different sizes & access times & purposes
- + decrease effective memory access time:
 - many misses in the L1 cache will be satisfied by the L2 cache
 - avoid going all the way to memory

Cache Hierarchies

**Level 1 cache goal: fast access
so minimize hit time (the common case)**

Cache Hierarchies

Level 2 cache goal: keep traffic off the system bus

Cache Metrics

$$\text{Hit (miss) ratio} = \frac{\#hits (\#misses)}{\#references}$$

- measures how well the cache functions
- useful for understanding cache behavior relative to the number of references
- intermediate metric

$$\text{Effective access time} = \text{HitTime} + \text{Miss Ratio} \cdot \text{Miss Penalty}$$

- (rough) average time it takes to do a memory reference
- performance of the memory system, including factors that depend on the implementation
- intermediate metric

Measuring Cache Hierarchy Performance

Effective Access Time for a cache hierarchy:...

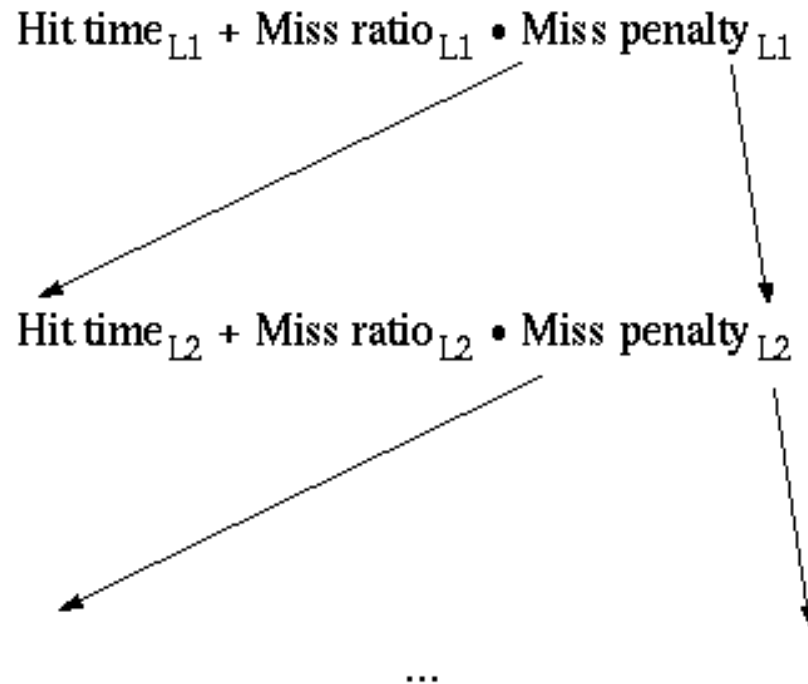

Measuring Cache Hierarchy Performance

Local Miss Ratio: $\frac{\text{\#misses}}{\text{\#accesses}}$ for that cache!

- # accesses for the L1 cache: the number of references
- # accesses for the L2 cache: the number of misses in the L1 cache

Example: 1000 references

40 L1 misses

10 L2 misses

local MR (L1):

local MR (L2):

Measuring Cache Hierarchy Performance

Global Miss Ratio: $\text{globalMR} = \frac{\text{\# misses in cache}}{\text{\# references generated by CPU}}$

Example: 1000 References
 40 L1 misses
 10 L2 misses

global MR (L1):

global MR (L2):

Miss Classification

Usefulness is in providing insight into the causes of misses

- does not explain what caused a particular, individual miss

Compulsory

- first reference misses
- decrease by

Capacity

- due to finite size of the cache
- decrease by

Conflict

- too many blocks map to the same set
- decrease by

Coherence (invalidation)

- decrease by