

**ECG SIGNAL
ACQUISITION
HARDWARE DESIGN**

Origin of Bioelectric Signals

Membrane potential

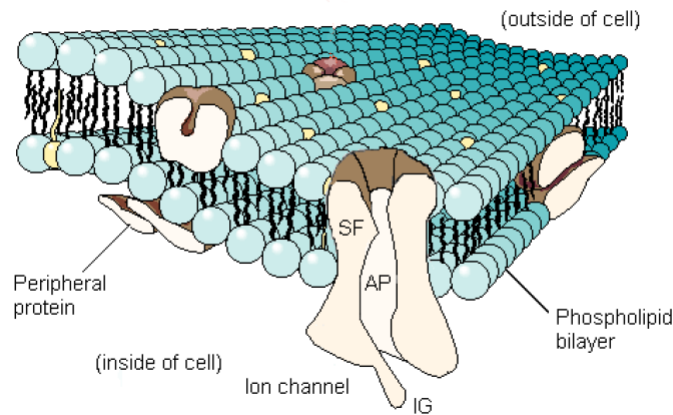
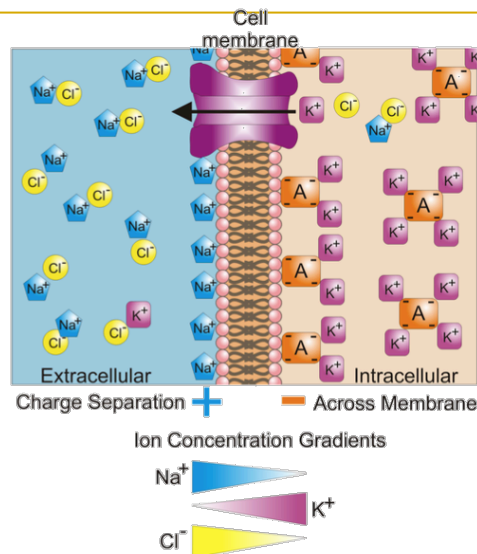

membrane composed of a lipid bilayer with embedded proteins



- Ion transporter/pump proteins actively push ions;
- ion channels allow ions to move.
- electrically equivalent to a set of batteries and resistors inserted in the membrane

As a result, we get a membrane resting potential of about -70mV

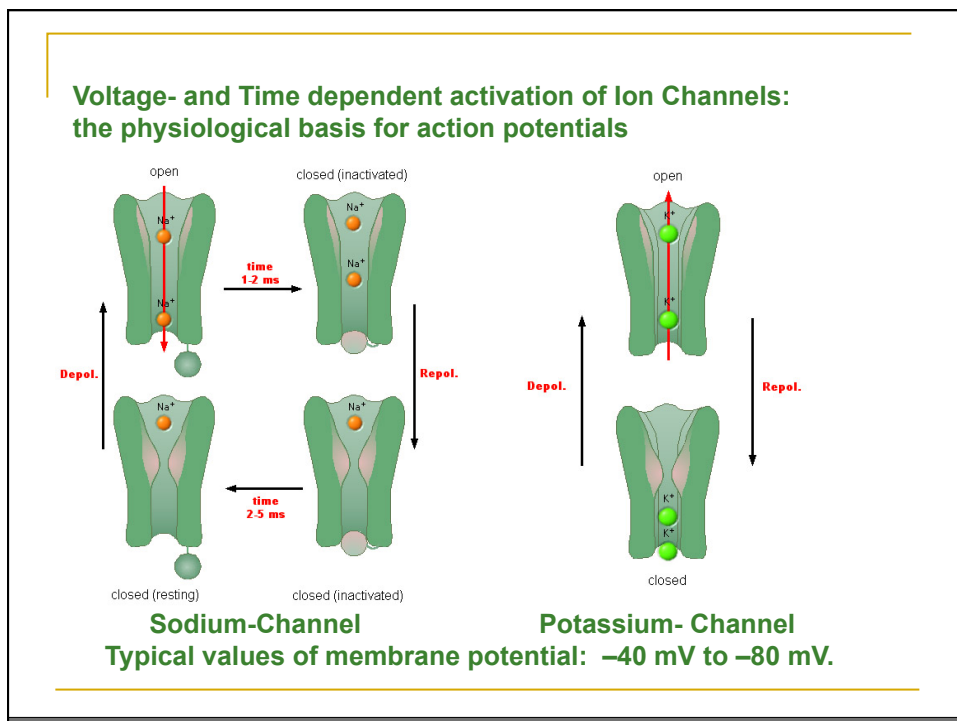
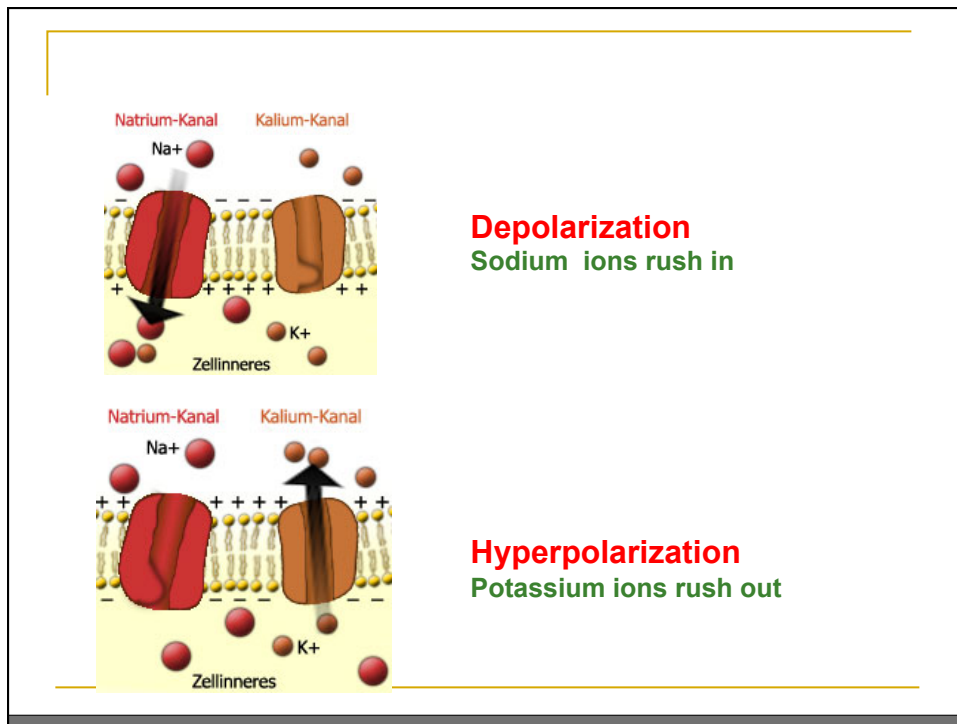

Bioelectric Signals

ECG	Electro-Cardiogram, Heart activity
EMG	Electro-Myogram, Muscle movement
EOG	Electro-Oculogram, Eye movement
EEG	Electro-Encephalogram
GSR	Galvanic Skin Response

- Measured with electrodes:
skin-electrode interface: Ions <--> Electrodes

Breathing, temperature, movement etc.

- Measured with other sensors / transducers:

**NTC, LDR, piezo-crystal, hall-sensor,
Accelerometer, Goniometer, ...**

>>>> **ECG** Electro-Cardiogram, Heart activity <<<<<<<<<<<<
EMG Electro-Myogram, Muscle movement
EOG Electro-Oculogram, Eye movement
EEG Electro-Encephalogram
GSR Galvanic Skin Response

- Measured with electrodes:
 skin-electrode interface: Ions <--> Electrodes

Breathing, temperature, movement etc.

- Measured with other sensors / transducers:

NTC, LDR, piezo-crystal, hall-sensor,
 Accelerometer, Goniometer, ...

BACKGROUND

■ ECG/EKG (electrocardiogram)

Records the heart's electrical activity:

- ✓ Heart beat rate
- ✓ Heart beat rhythm
- ✓ Heart strength and timing

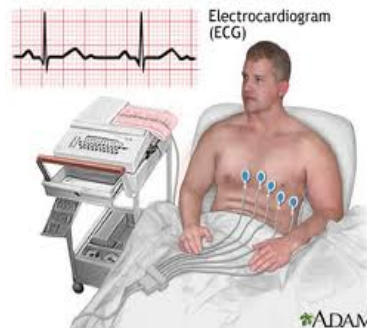

BACKGROUND

- **The heart's electrical system:**

- Sinoatrial(SA) node
- Atrioventricular(AV) node
- His-Purkinje system

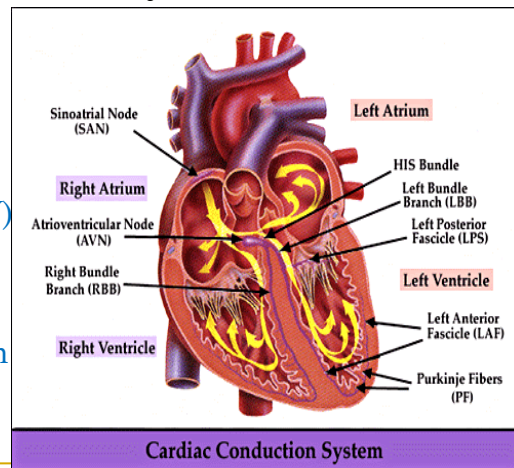

The heart's electrical system:

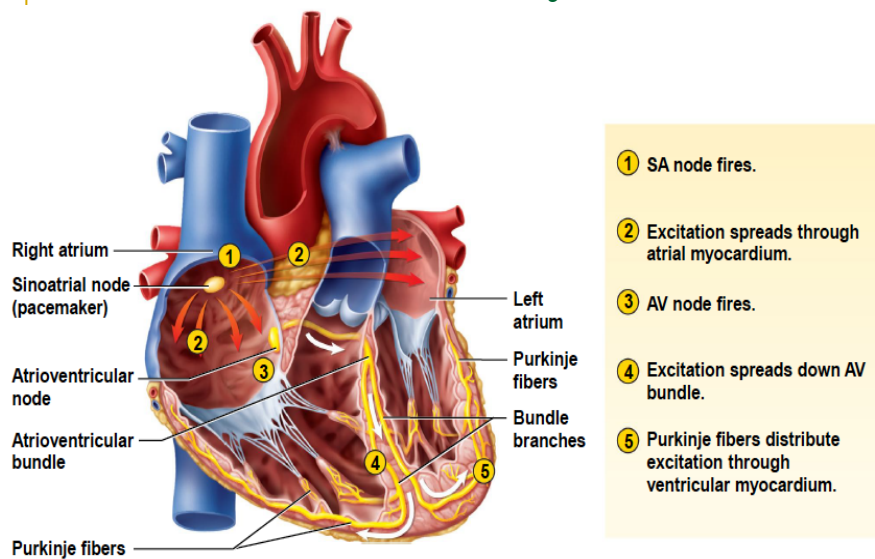

BACKGROUND

ECG works mostly by detecting and amplifying the tiny potential changes on the skin that are caused when the electrical signal in the heart muscle is charged and spread during each heart beat.

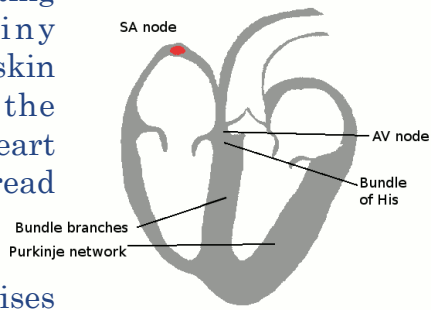

This is detected as tiny rises and falls in the voltage between two electrodes placed either side of the heart.

BACKGROUND

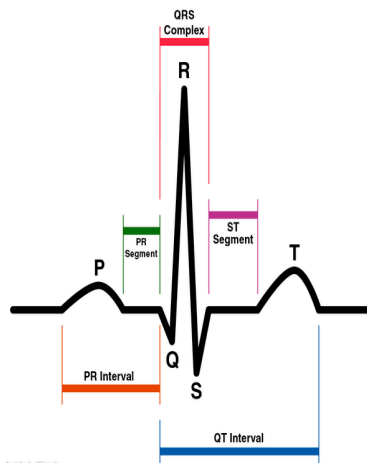

Schematic representation of normal ECG

P wave: signal spread from SA node to make the atria contract.

P-Q Segment: signal arrives AV node stay for a instant to allow the ventricle to be filled with blood.

Q wave :After the Bundle of His the signal is divided into two branches and run through the septum.

R,S wave: Left and right ventricle contraction are marked by the R,S wave.

T wave: ventricle relaxing

ECG SIGNAL

- ECG bio-signal typical specifications:

- low differential voltage from 0.4 to 3 mV
- high common-mode rejection ratio level
- low frequency range
- high noise

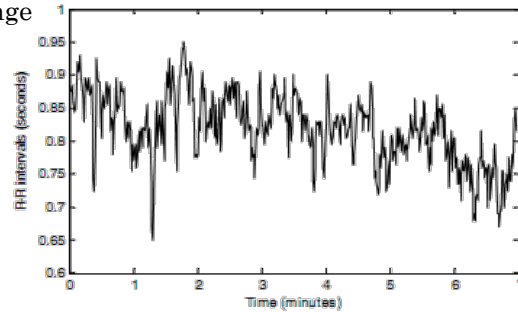
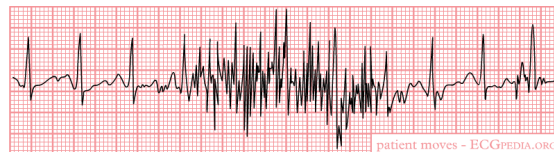

Fig. 6. Seven minutes RR intervals.

ECG SIGNAL

- Artifacts (disturbances) can have many causes. Common causes are:

- Movement



Sudden movement



Baseline drift

ECG SIGNAL

□ Electrical interference

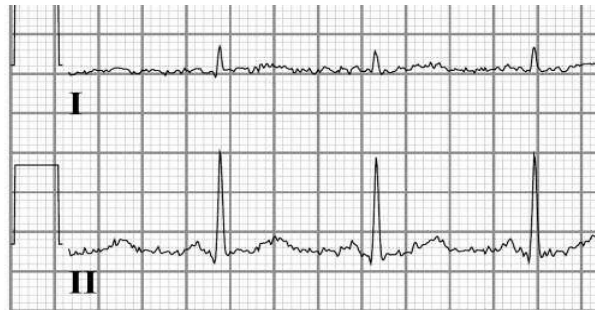

→ From a nearby electrical appliance. A typical example is a 100 Hz background distortion from fluorescent lights. To be confused with atrial fibrillation.

ECG ELECTRODE

■ Lead

- ◆ The signal recorded as the difference between two potentials on the body surface is called an "**ECG lead**". Each lead is said to look at the heart from a different angle.

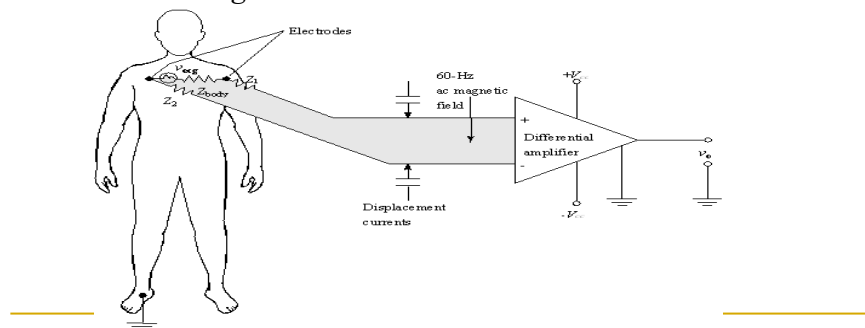

ELECTRODE

■ Lead position

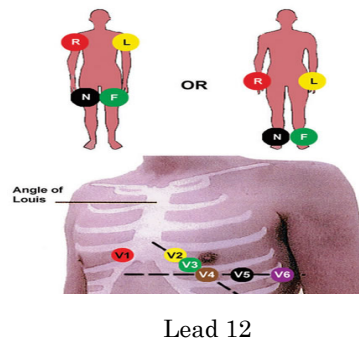
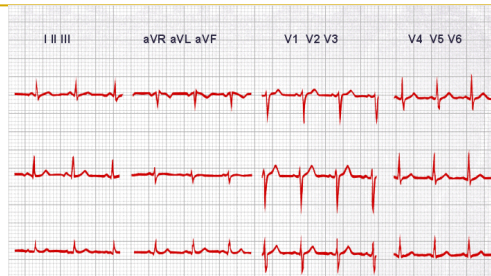
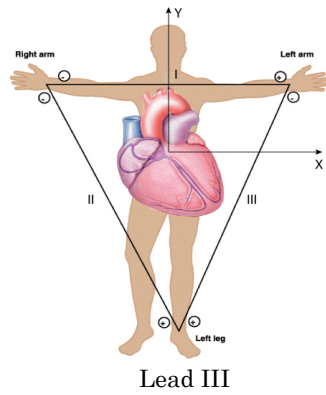

ECG ELECTRODE

A typical surface electrode used for ECG recording is made of Ag/AgCl, as shown on right Figure. The disposable electrodes are attached to the patients' skin and can be easily removed.

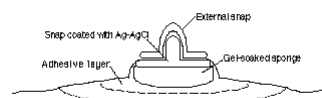

- ① **Limb Leads (Bipolar)**
- ② **Chest Leads (Unipolar)**
- ③ **Augmented Limb Leads (Unipolar)**

Wet, dry and insulating...



First, to make sure we know where the heart is

...

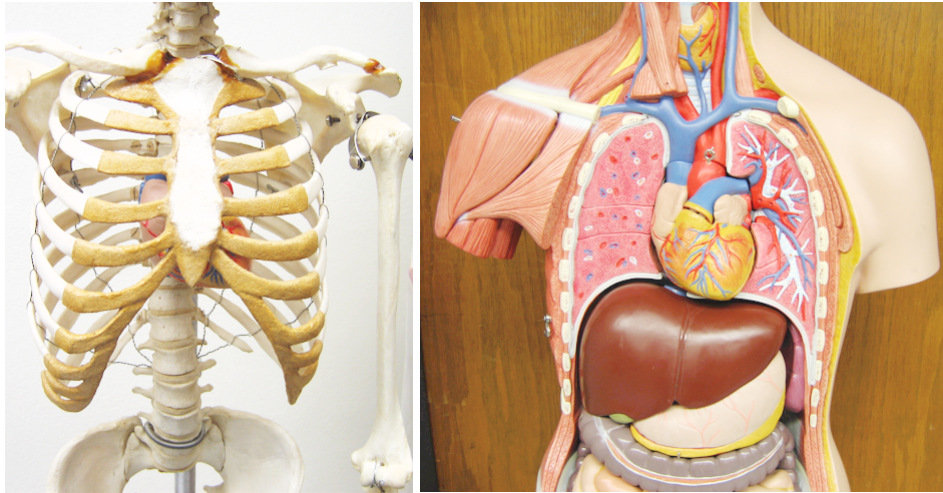

Sensing the heart's electrical activity via electrodes (contacts placed on the surface of the body)

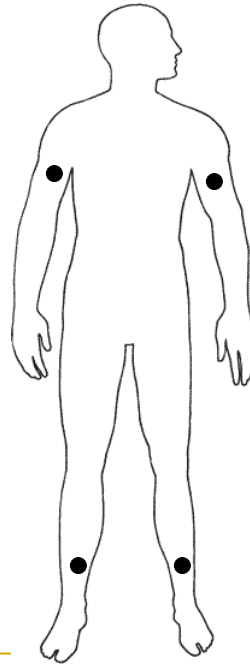

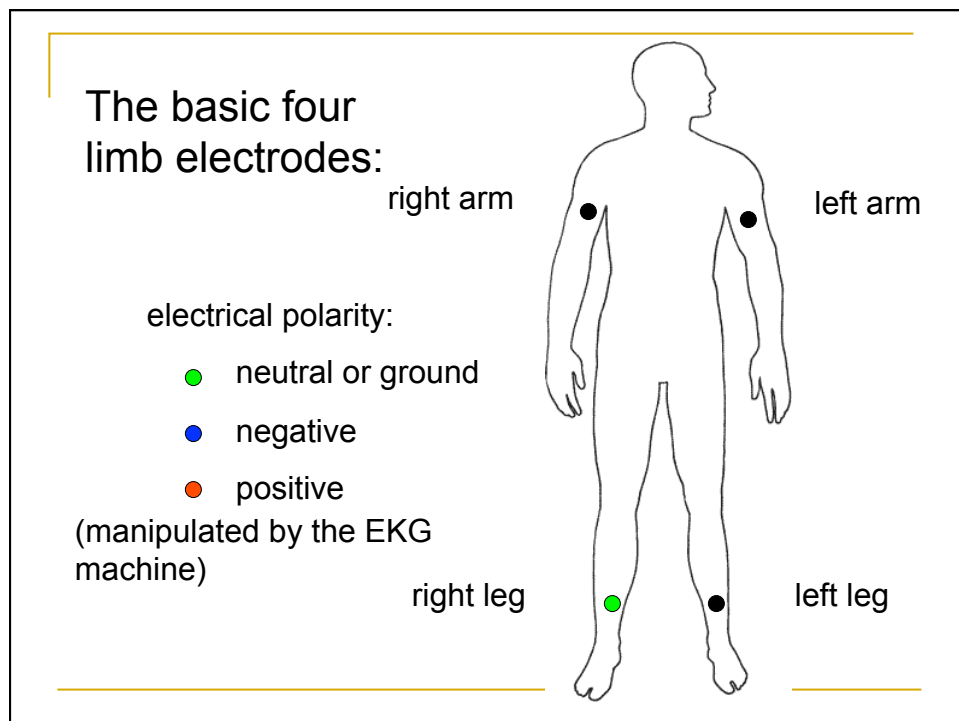
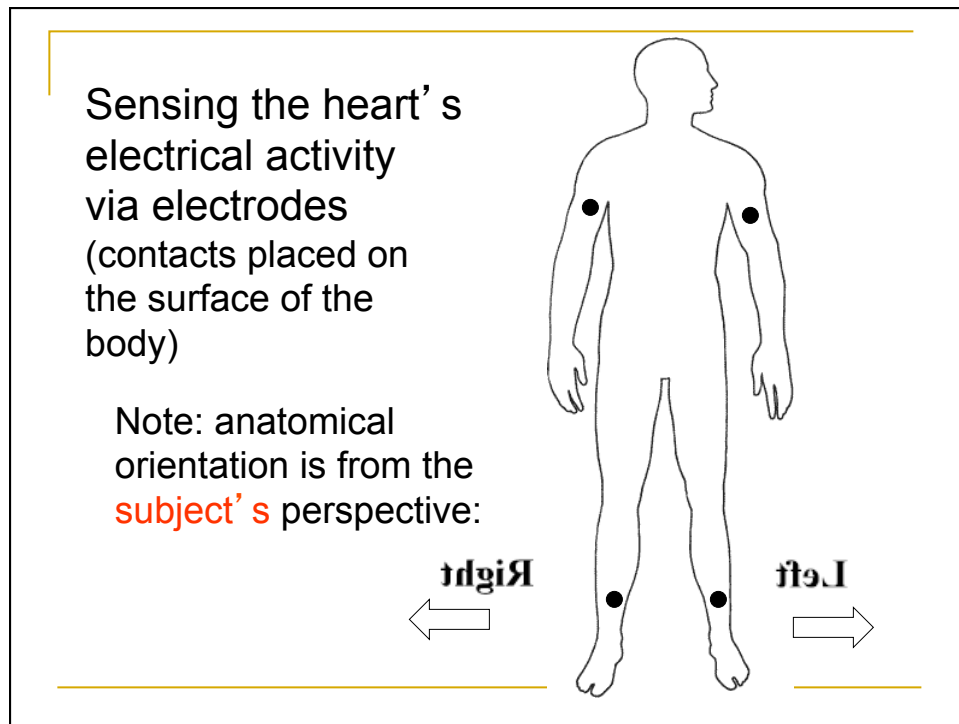

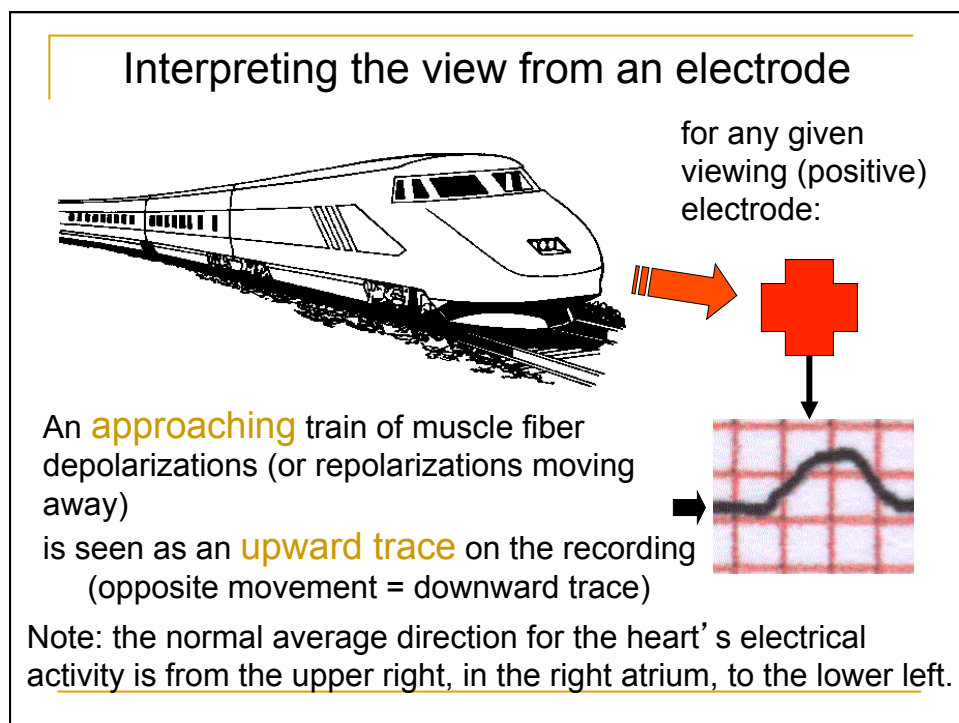
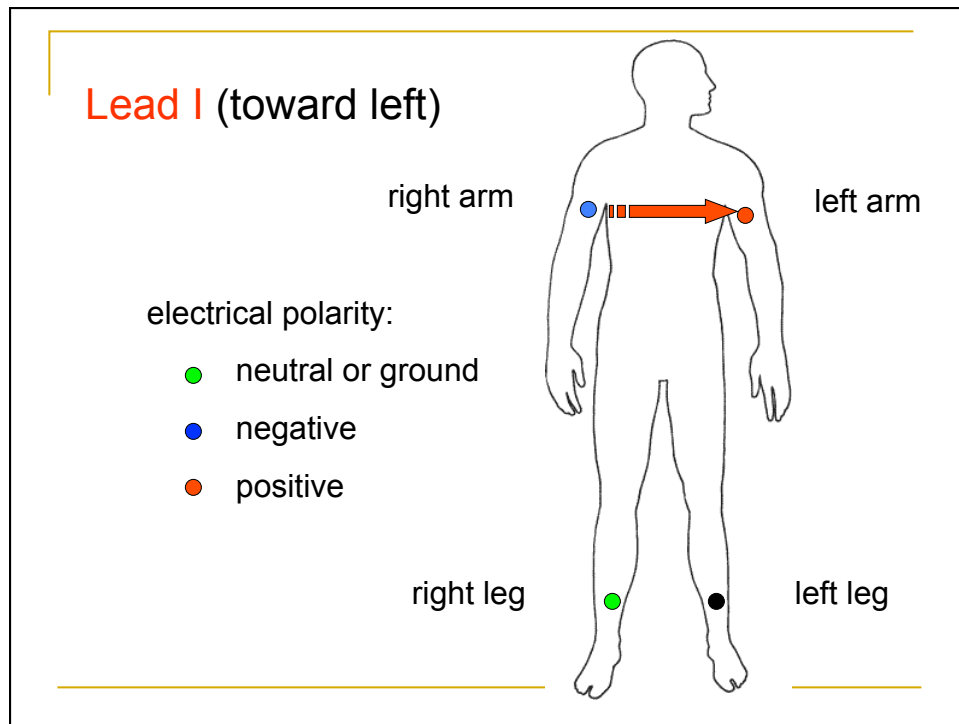

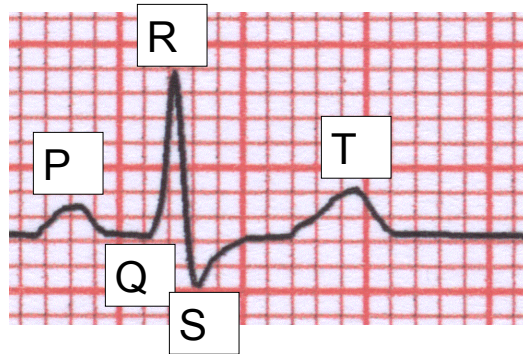

The main, typical waves of an EKG.

(This particular tracing does not show a Q wave, a downward wave just before the R wave.)

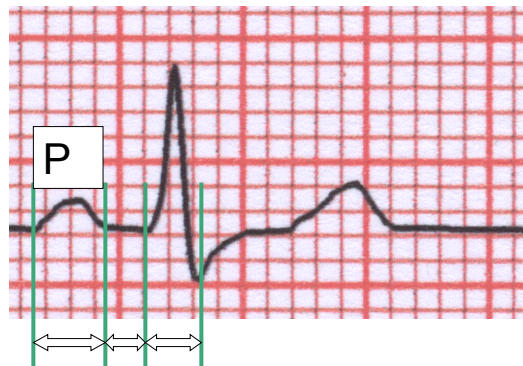

ATRIA: depol-pause-repol

(atrial repolarization is obscured by ventricular depolarization)

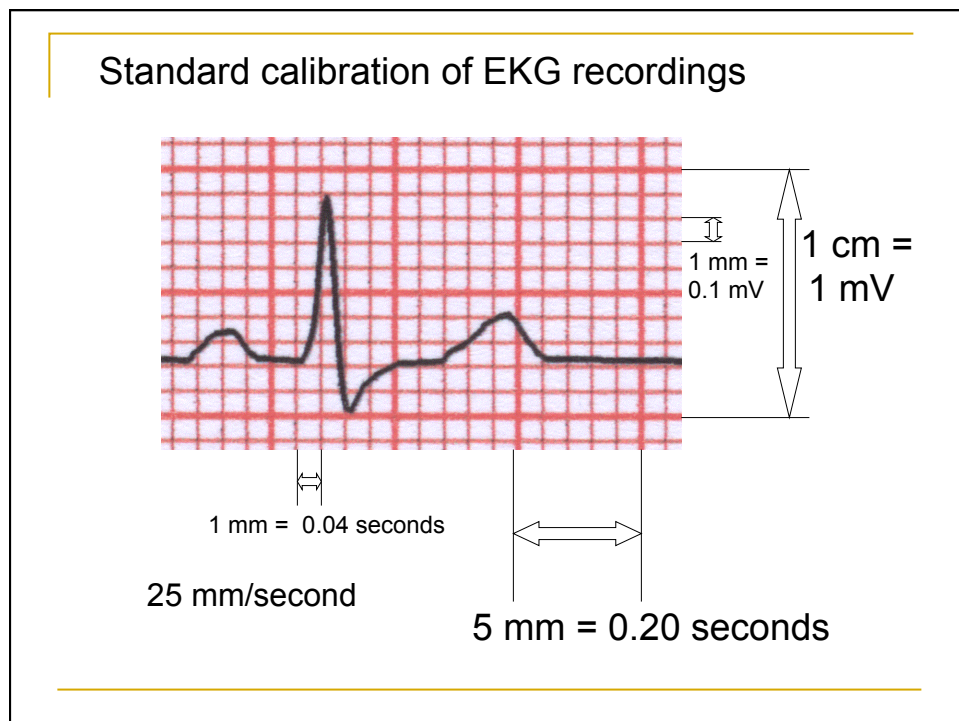
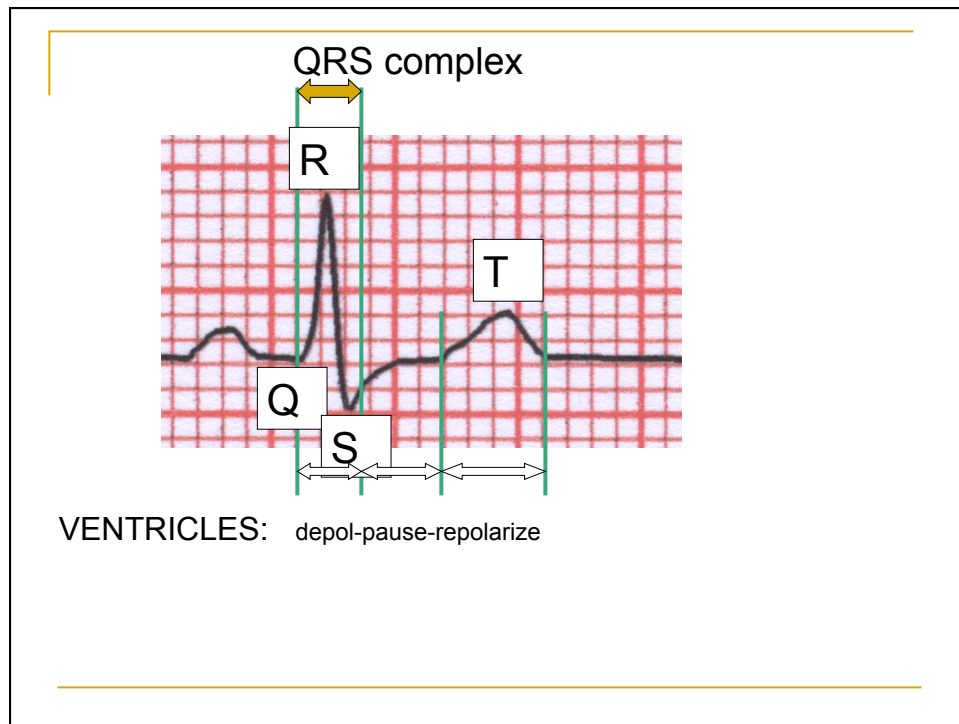

Electrocardiograph Block Diagram

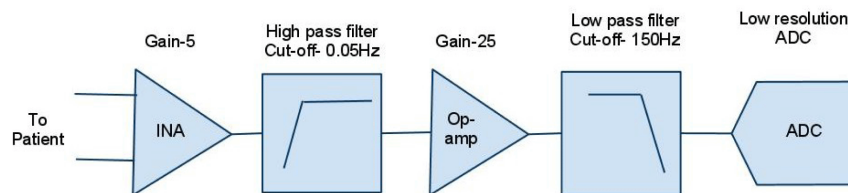

Characteristics of ECG signals

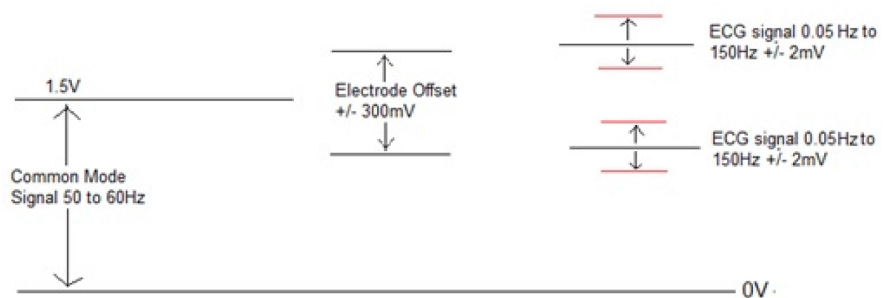

the actual signal value will be ~0.4mV in an offset environment of 300mV.

sources of noise in ECG signals

- Baseline wander (low frequency noise)
- Power line interference (60Hz noise from power lines)
- Muscle noise (This noise is very difficult to remove as it is in the same region as the actual signal. It is usually corrected in software.)
- Other interference (i.e., radio frequency noise from other equipment)

Removal of common mode noise

- Use instrumentation amplifiers with very high common mode rejection ratios on the order of 100dB
- Drive the patient body with an inverted common mode signal.
- Apply software algorithms after acquisition for the removal of noise

Our EKG Analog Front End Circuit

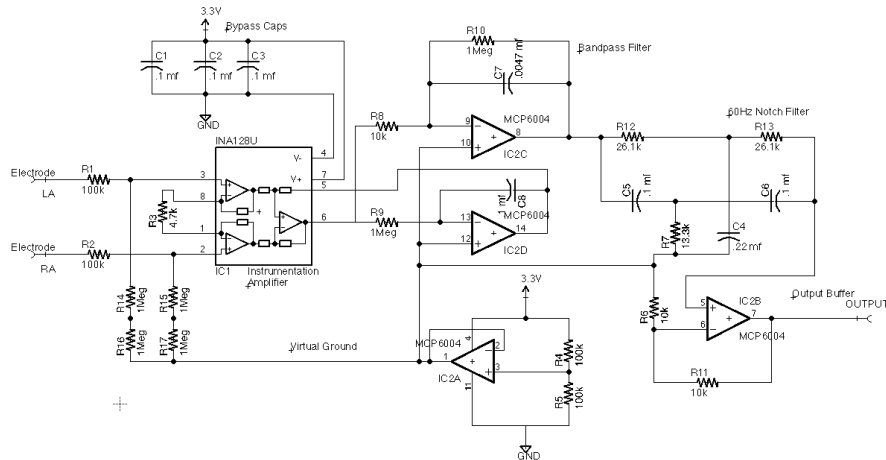

Instrumentation Amplifier

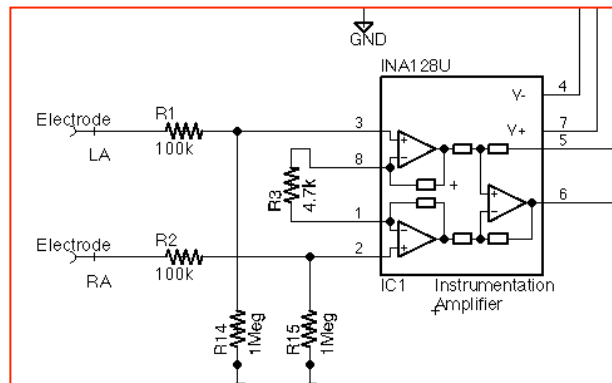

- High Common Mode Rejection– 120dB minimum
- Settable gain of 1 to 1000x, controlled by R3
- Low voltage, Single supply

Virtual Ground Circuit

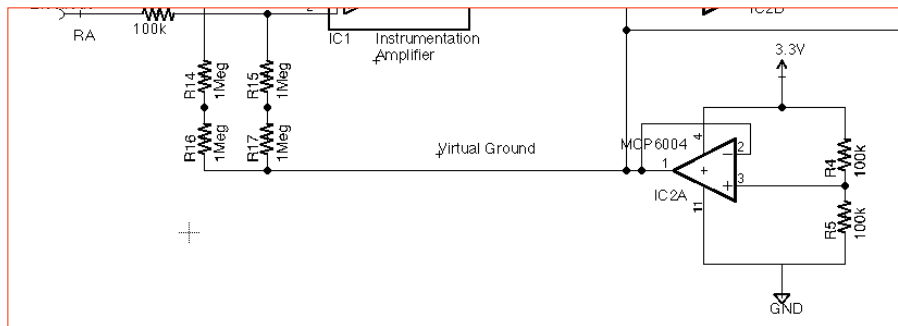

- Virtual Ground– $3.3\text{V}/2$
- allows signals 0-3.3v swing

Band Pass filter ~1 Hz to ~40 Hz

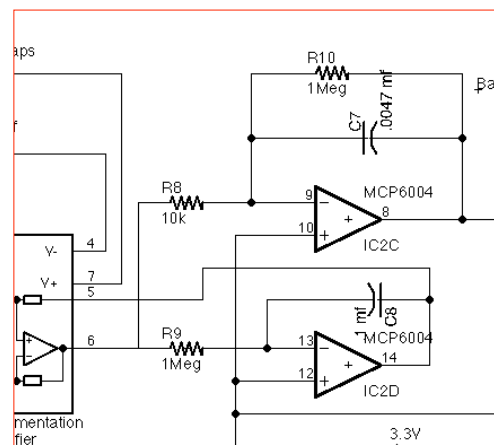

60 Hz Notch filter and output buffer

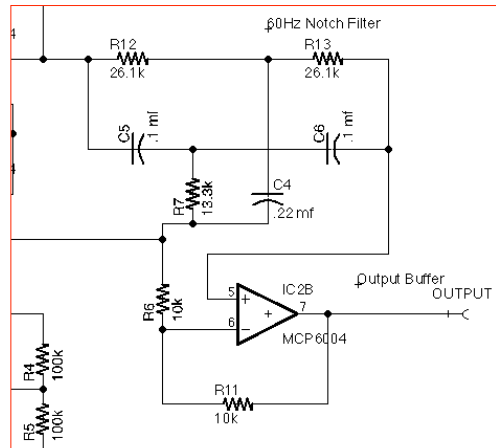

Our EKG Analog Front End Circuit

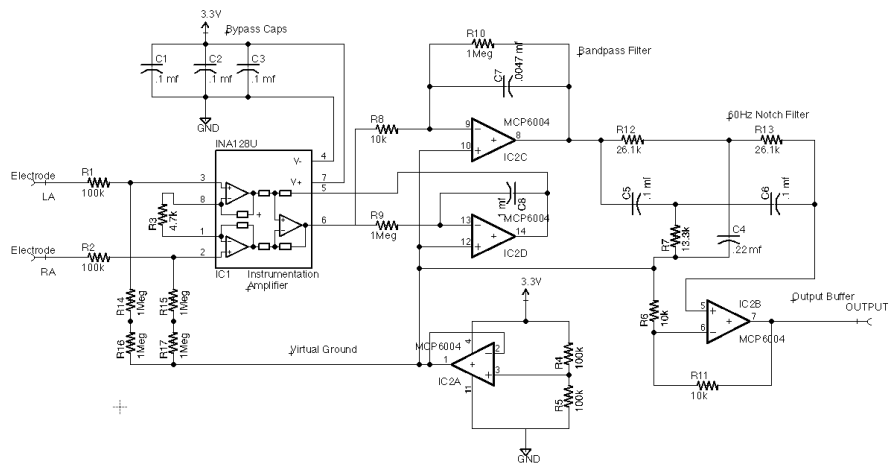

This week's Lab 7

- Build an Analog Front End circuit for an ECG
- Test it
- Connect it to the Teensy ADC

Next Week– display traces on LCD and calibrate
To Standard Grid
Add digital processing to clean up signal

Final week– Add diagnostic signal processing routines

Our EKG Analog Front End Circuit

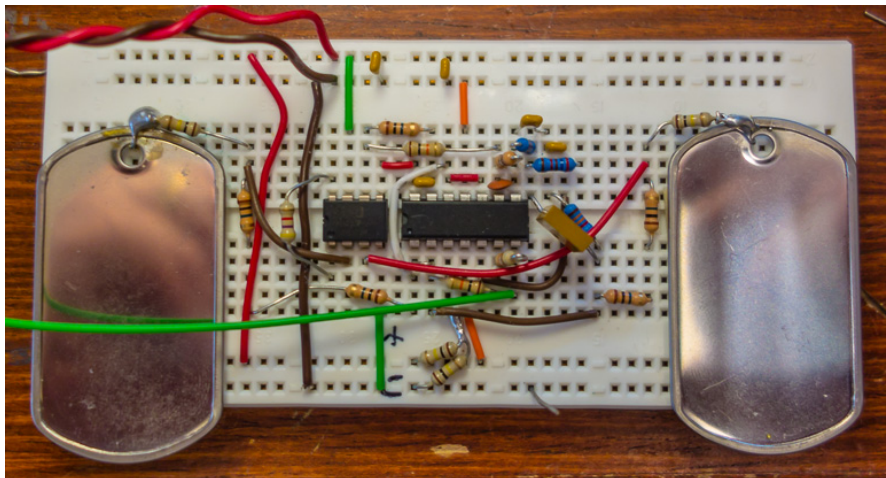

Our EKG Analog Front End Circuit

