

CSE/EE 461 – Lecture 16

Bandwidth Allocation

David Wetherall
djw@cs.washington.edu

Last Time

- The Transport Layer
- Focus
 - How do we decide when to retransmit?
- Topics
 - Estimating RTTs
 - Karn/Partridge algorithm
 - Jacobson/Karels algorithm

Application
Presentation
Session
Transport
Network
Data Link
Physical

This Lecture

- The Transport Layer
- Focus
 - How do we share bandwidth?
- Topics
 - Congestion control
 - Fairness

Application
Presentation
Session
Transport
Network
Data Link
Physical

Bandwidth Allocation

- How fast should the Web server send packets?
- Two big issues to solve!
 - Congestion
 - sending too fast will cause packets to be lost in the network
 - Fairness
 - different users should get their fair share of the bandwidth
- Often treated together (e.g. TCP) but needn't be

Congestion

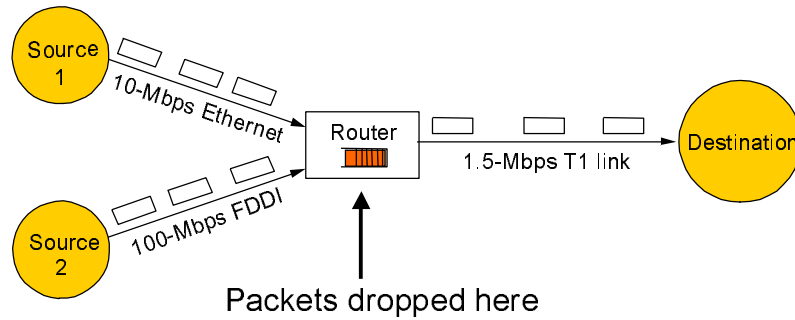

- Buffer intended to absorb bursts when input rate > output
- But if sending rate is persistently > drain rate, queue builds
- Dropped packets represent wasted work; goodput < throughput

djw // CSE/EE 461, Winter 2001

Fairness

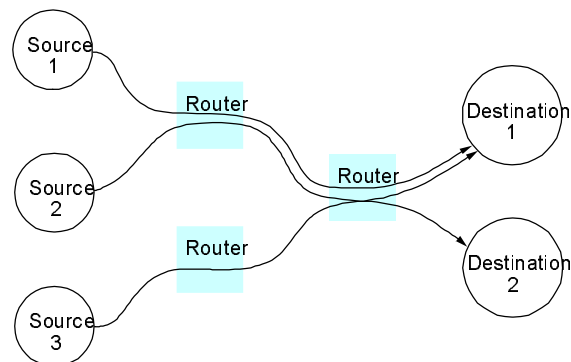

- Each flow from a source to a destination should get an equal share of the bottleneck link ... depends on paths and other traffic

djw // CSE/EE 461, Winter 2001

Bandwidth Allocation Approaches

- Open versus Closed loop
 - Open: reserve allowed traffic with network; avoid congestion
 - Closed: use network feedback to adjust sending rate
- Host-based versus Network support
 - Who is responsible for adjusting/enforcing allocations?
- Window versus Rate based
 - How is allocation expressed? Window and rate are related.
- Internet depends on TCP for bandwidth allocation
 - TCP is a host-driven, window-based, closed loop mechanism

djw // CSE/EE 461, Winter 2001

L16.7

Design Choices

- TCP/Internet provides “best-effort” service
 - Implicit network feedback, host controls via window.
 - No strong notions of fairness
- A network in which there are QOS (quality of service) guarantees
 - Rate-based reservations natural choice for some apps
 - But reservations are need a good characterization of traffic
 - Network involvement typically needed to provide a guarantee
- Former tends to be simpler to build, latter offers greater service to applications but is more complex.

djw // CSE/EE 461, Winter 2001

L16.8

Evaluating Congestion Control

- Power = throughput / delay
- At low load, throughput goes up and delay remains small
- At moderate load, delay is increasing (queues) but throughput doesn't grow much
- At high load, much loss and delay increases greatly due to retransmissions

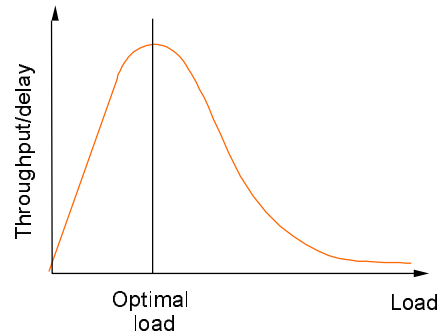

djw // CSE/EE 461, Winter 2001

Evaluating Fairness

- First, need to define what is a fair allocation
 - Consider n flows, each wants a fraction f_i of the bandwidth
- Min-max fairness:
 - First satisfy all flows evenly up to the lowest f_i . Repeat with the remaining bandwidth.
- Also proportional fairness
 - Depends on path length ...

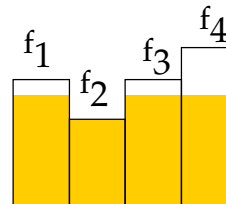

djw // CSE/EE 461, Winter 2001

L16.10

Jain's Fairness Index

- How do we compute the fairness of an allocation?
 - If all flows have an equal share at a router it's "fair"
 - But how unfair are unequal allocations?
- Jain's fairness index:
 - For n flows each receiving a fraction f_i of the bandwidth
 - Fairness = $(\sum f_i)^2 / (n \times \sum f_i^2)$
 - Always between 0 and 1, 1 for equal allocations
 - If only k out of n flows get bandwidth, drops to k/n

Key Concepts

- Network mechanisms for bandwidth allocation should avoid congestion and provide fairness
- Congestion occurs when buffers inside the network fill with excess traffic
 - Queuing leads to increased latency and eventually to loss
- Fairness means that competing traffic flows gain a "fair share" of the available bandwidth
 - Min-max fairness is one definition of "fair share"