

Announcements

No midterm

Project 3 will be done in pairs

- same partners as for project 2

Global Alignment and Structure from Motion



(Adapted from slides by Noah Snavely)

Today's Readings

- Photo Tourism (Snavely et al., SIGGRAPH 2006)
 - http://phototour.cs.washington.edu/Photo_Tourism.pdf

Problem: Drift

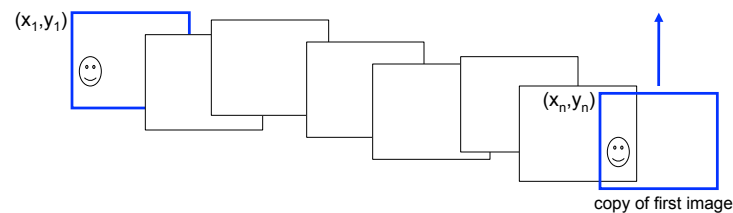

Solution

- add another copy of first image at the end
- this gives a constraint: $y_n = y_1$
- there are a bunch of ways to solve this problem
 - add displacement of $(y_1 - y_n)/(n - 1)$ to each image after the first
 - compute a global warp: $y' = y + ax$
 - run a big optimization problem, incorporating this constraint
 - » best solution, but more complicated
 - » known as “bundle adjustment”

Global optimization

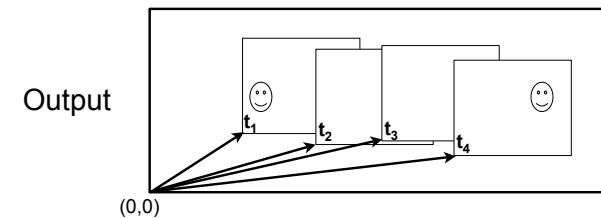
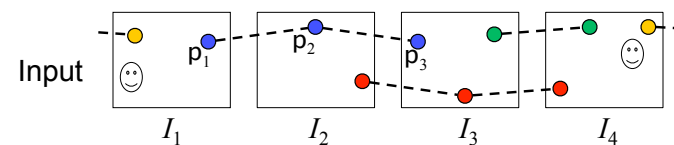

We want to estimate t_i . We know p_i

- how do t_i relate to p_i ?

Global optimization

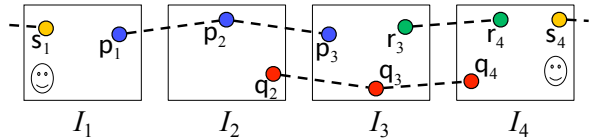

Recipe

1. Identify the **variables** you want to estimate
 - in our case: t_i
2. Identify a set of **objectives** you want to satisfy
 - in our case: $p_i - p_j = t_i - t_j$ and similar for q, r, s
3. Define an **objective function** F over these variables, whose minimum occurs at the “answer” for these variables
4. Find the **minimum** of F

Objective function

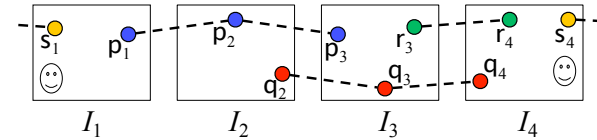

Objective function

$$\sum_{i=2}^3 \|(p_i - p_{i-1}) - (t_i - t_{i-1})\|^2$$

+ similar terms for q, r, s

Objective function

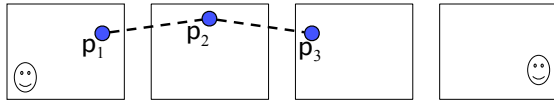

Objective function $\sum_{i=2}^3 \|(p_i - p_{i-1}) - (t_i - t_{i-1})\|^2$

Matrix form

$$\begin{bmatrix} -1 & 0 & 1 & 0 & 0 & 0 & 0 & 0 \\ 0 & -1 & 0 & 1 & 0 & 0 & 0 & 0 \\ 0 & 0 & -1 & 0 & 1 & 0 & 0 & 0 \\ 0 & 0 & 0 & -1 & 0 & 1 & 0 & 0 \end{bmatrix} \begin{bmatrix} x_1 \\ y_1 \\ x_2 \\ y_2 \\ x_3 \\ y_3 \\ x_4 \\ y_4 \end{bmatrix} = \begin{bmatrix} u_2 - u_1 \\ v_2 - v_1 \\ u_3 - u_2 \\ v_3 - v_2 \end{bmatrix}$$

$t_i = (x_i, y_i)$ $p_i = (u_i, v_i)$

Objective Function

Adding in q, r, s give a larger matrix equation

$$\begin{bmatrix} -1 & 0 & 1 & 0 & 0 & 0 & 0 & 0 \\ 0 & -1 & 0 & 1 & 0 & 0 & 0 & 0 \\ 0 & 0 & -1 & 0 & 1 & 0 & 0 & 0 \\ 0 & 0 & 0 & -1 & 0 & 1 & 0 & 0 \\ & & & \vdots & & & & \end{bmatrix} \begin{bmatrix} x_1 \\ y_1 \\ x_2 \\ y_2 \\ x_3 \\ y_3 \\ x_4 \\ y_4 \end{bmatrix} = \begin{bmatrix} u_2 - u_1 \\ v_2 - v_1 \\ u_3 - u_2 \\ v_3 - v_2 \\ \vdots \end{bmatrix}$$

A **x** **b**

Defines a least squares problem: minimize $\|Ax - b\|$

- Solution: $\hat{x} = (A^T A)^{-1} A^T b$
- Problem: there are multiple solutions for \hat{x} ! ($\det(A^T A) = 0$)
- We can add a global offset to a solution \hat{x} and get the same error

Ambiguity in the solution

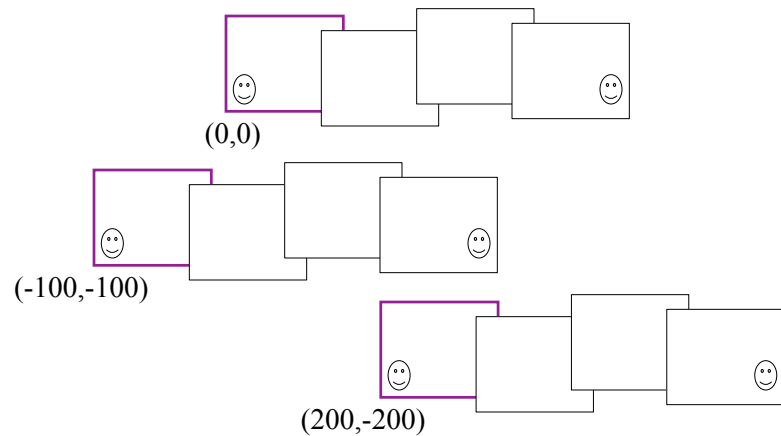

- Each of these solutions has the same error
- Called the gauge ambiguity
- Solution: fix the translation of one image ($\mathbf{t}_1 = (0,0)$)

Structure from motion

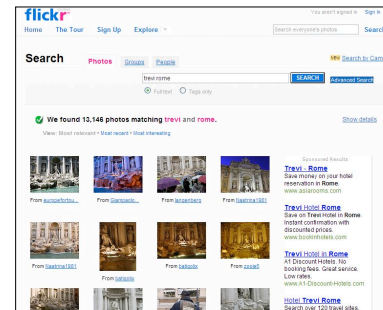

Images on the Internet



Computed 3D structure

Structure from motion

aka "bundle adjustment" (texts: [Zisserman](#); [Faugeras](#))

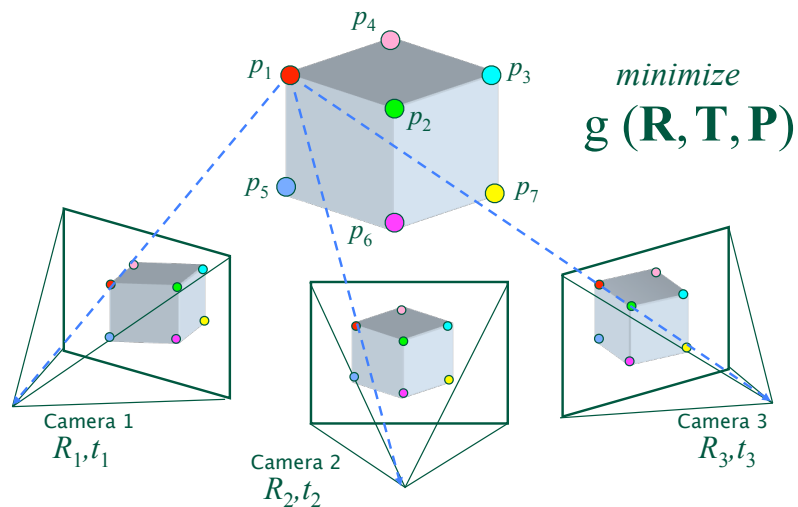

SfM objective function

Given point \mathbf{x} and rotation and translation \mathbf{R}, \mathbf{t}

$$\begin{bmatrix} x' \\ y' \\ z' \end{bmatrix} = \mathbf{R}\mathbf{x} + \mathbf{t} \quad \begin{matrix} u' = \frac{fx'}{z'} \\ v' = \frac{fy'}{z'} \end{matrix} \quad \begin{bmatrix} u' \\ v' \end{bmatrix} = \mathbf{P}(\mathbf{x}, \mathbf{R}, \mathbf{t})$$

Minimize sum of squared reprojection errors:

$$g(\mathbf{X}, \mathbf{R}, \mathbf{T}) = \sum_{i=1}^m \sum_{j=1}^n w_{ij} \cdot \left\| \underbrace{\mathbf{P}(\mathbf{x}_i, \mathbf{R}_j, \mathbf{t}_j)}_{\text{predicted image location}} - \underbrace{\begin{bmatrix} u_{i,j} \\ v_{i,j} \end{bmatrix}}_{\text{observed image location}} \right\|^2$$

Solving structure from motion

Minimizing g is difficult:

- g is non-linear due to rotations, perspective division
- lots of parameters: 3 for each 3D point, 6 for each camera
- difficult to initialize
- gauge ambiguity: error is invariant to a similarity transform (translation, rotation, uniform scale)

Many techniques use non-linear least-squares optimization (*bundle adjustment*)

- Levenberg-Marquardt is a popular algorithm
- http://en.wikipedia.org/wiki/Levenberg-Marquardt_algorithm

Good code online

- Bundler: <http://phototour.cs.washington.edu/bundler/>
- Multicore: <http://grail.cs.washington.edu/projects/mcba/>

Photo Tourism



Photo Tourism

Exploring photo collections in 3D

Microsoft

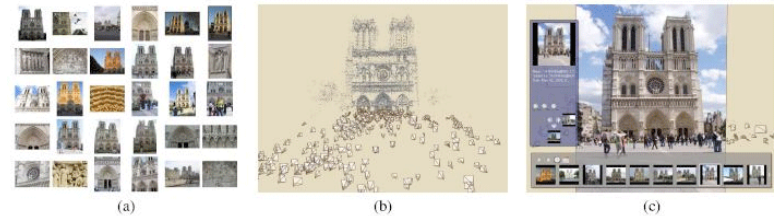

Photo tourism video: <http://www.youtube.com/watch?v=5Ji84zb2r8s>

Photosynth: <http://photosynth.net/>

flickr

You aren't signed in Sign In Help

Home The Tour Sign Up Explore

Search everyone's photostream Search

Search

Photos Groups People

rome

SEARCH

Advanced Search Search by Camera

Full text Tags only

We found 1,281,363 results matching rome.

View: Most relevant • Most recent • Most interesting Show: Details • Thumbnails



From Dmitry...



From Lisa...



From Lisa...



From ierkhead29



From Lisa...



From Lisa...



From Lisa...



From Dmitry...



From Lisa...



From formichel



From Lisa...



From Rick's Picks

Sponsored Results

\$387 Italy Flights
Fly one-way to Italy from \$387.
Book your flight before April 24.
www.AirFrance.us

What to Do Rome
55+ Things to do in Rome on Viator. See the Vatican, Colosseum & more.
www.viator.com/Rome

Rome with Kids
Get Extra Savings on a Family Vacation to Rome. Limited Time Only.
www.AdventuresByDisney.com

Fly to Italy from \$499 Round Trip
Travel to Italy between May 1 - 31 from \$499 per Person.
www.EuroFlyusa.com

Rome Italy Day Tours
Private tours of Rome A variety of tours available....

flickr

Home The Tour Sign Up Explore

rome trevi fountain

ALL SIZES



The wife and I at the Trevi fountain in 2006

Would you like to comment?

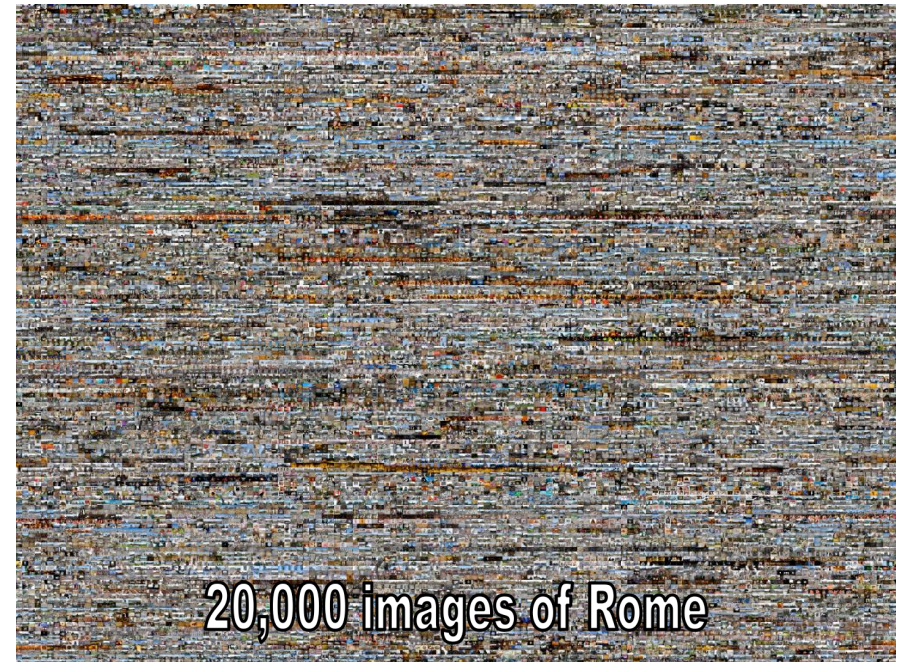



Reconstructing Rome

In a day...

From ~1M images

Using ~1000 cores

Sameer Agarwal, Noah Snavely, Rick Szeliski, Steve Seitz

<http://grail.cs.washington.edu/rome>

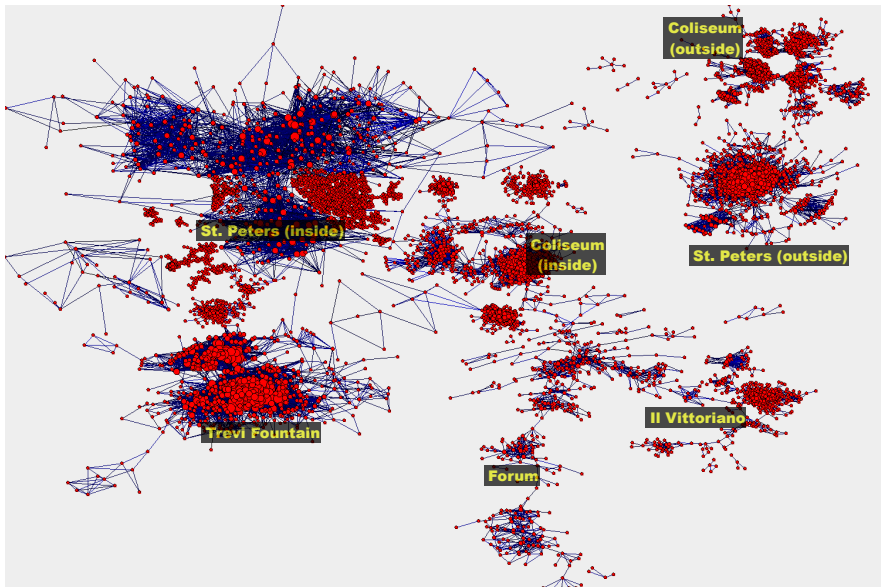

Rome 150K: Colosseum

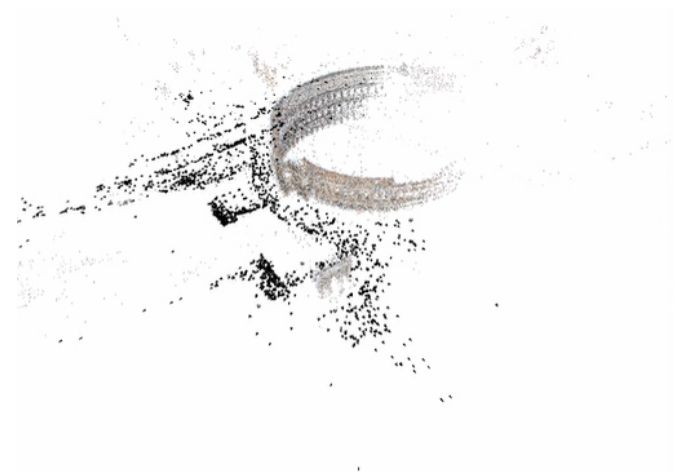

Rome: St. Peters



Venice (250K images)



Venice: Canal



Dubrovnik



More info

- Rome-in-a-day page
 - <http://grail.cs.washington.edu/rome>