

# Recurrent Neural Networks

---

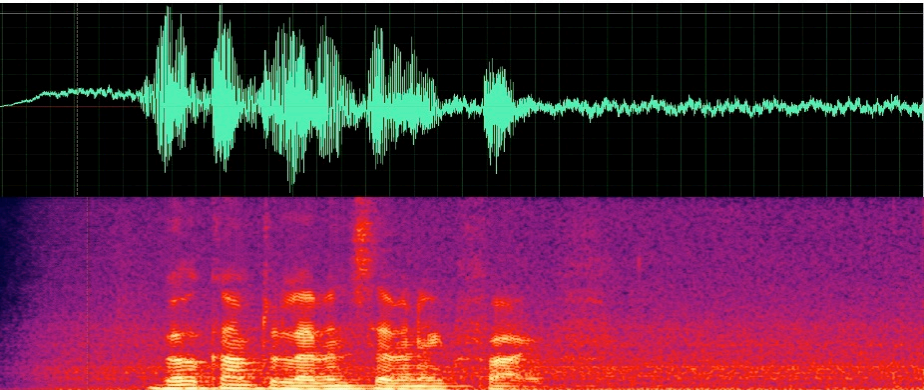

# Sequence Data



检测语言 英语 中文 德语

↔ 中文 (简体) 英语 日语

Deep learning is a popular area in AI.

深度学习是AI的热门领域。

Shēndù xuéxí shì AI de rènmén lǐngyù.

38 / 5000

🔊 🔊 📄 ✎ 🔄

# State-Space Model

- $h_t$ : hidden state
- $X_t$ : input
- $Y_t$ : output
- $Y_t, h_t = f(h_{t-1}, X_t; \theta)$
- $h_{-1}$ : initial state

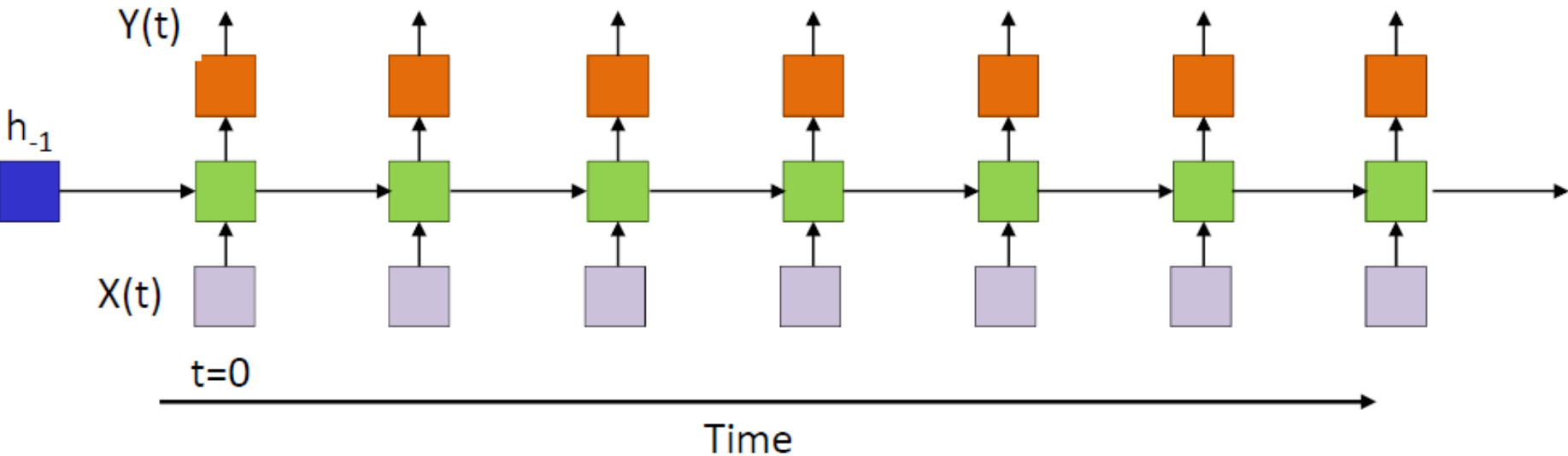

# Recurrent Neural Network

- $h_t$ : hidden state
- $X_t$ : input
- $Y_t$ : output
- $Y_t, h_t = f(h_{t-1}, X_t; \theta)$
- $h_{-1}$ : initial state

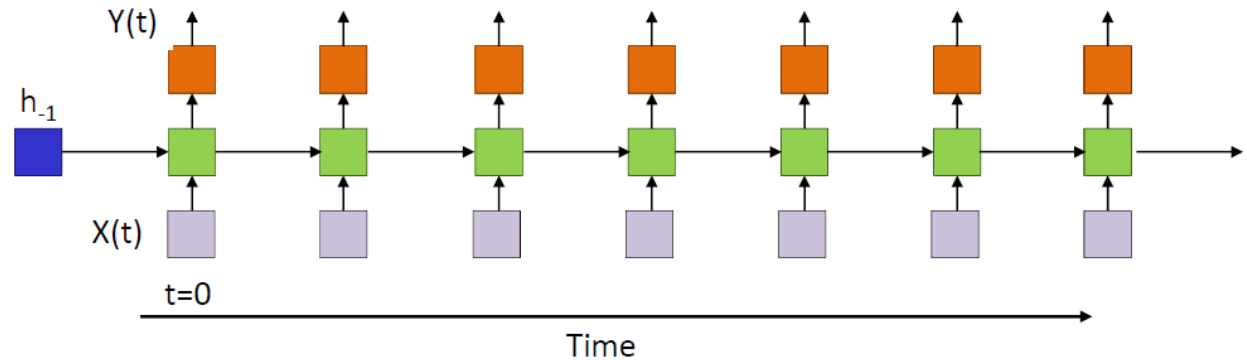

## Fully-connect NN vs. RNN

- $h_t$ : a vector summarizes all past inputs (a.k.a. “memory”)
- $h_{-1}$  affects the entire dynamics (typically set to zero)
- $X_t$  affects all the outputs and states after  $t$
- $Y_t$  depends on  $X_0, \dots, X_t$

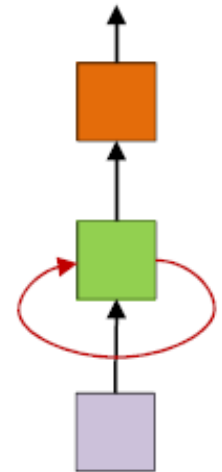

# Recurrent Neural Network

- $h_t$ : hidden state
- $X_t$ : input
- $Y_t$ : output
- $Y_t, h_t = f(h_{t-1}, X_t; \theta)$
- $h_{-1}$ : initial state

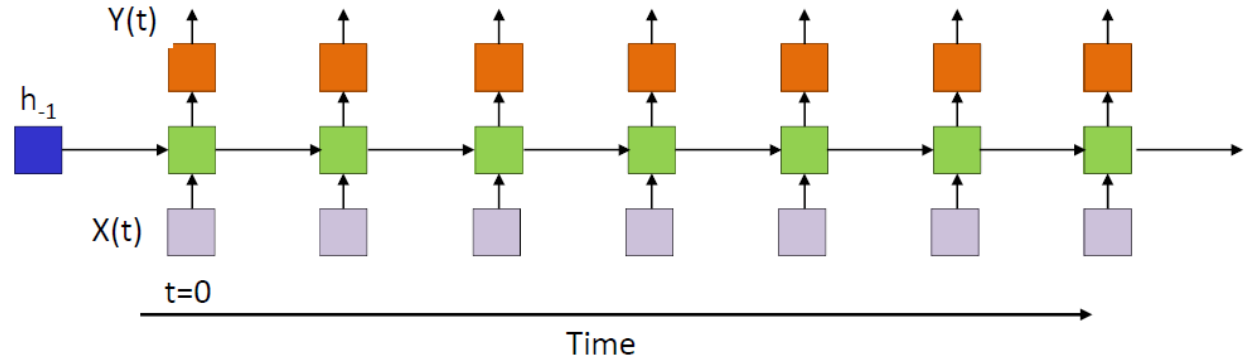

## Fully-connect NN vs. RNN

- RNN can be viewed as repeated applying fully-connected NNs
- $h_t = \sigma_1(W^{(1)}X_t + W^{(11)}h_{t-1} + b^{(1)})$
- $Y_t = \sigma_2(W^{(2)}h_t + b^{(2)})$
- $\sigma_1, \sigma_2$  are activation functions (sigmoid, ReLU, tanh, etc)

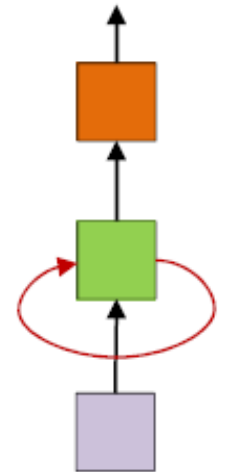

# Recurrent Neural Network

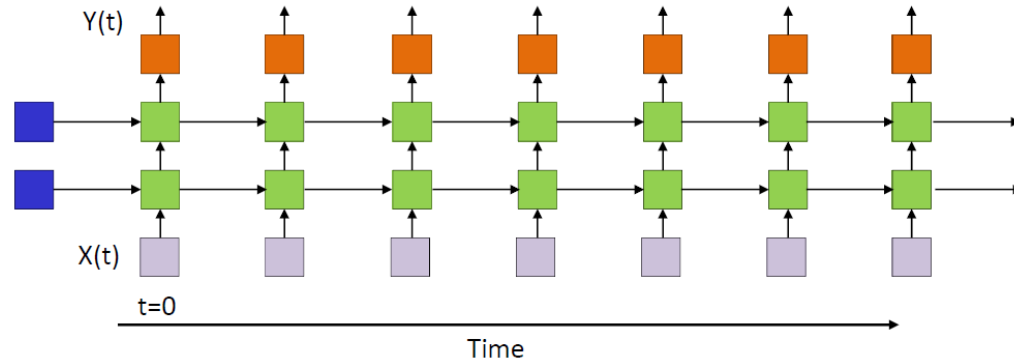

Stack  $K$  layers of fully-connected NN

- $h_t^{(k)}$ : hidden state
- $X_t$ : input
- $Y_t$ : output
- $h_t^{(1)} = f_1^{(1)}(h_{t-1}^{(1)}, X_t; \theta)$
- $h_t^{(k)} = f_1^{(k)}(h_{t-1}^{(k)}, h_t^{(k-1)}; \theta)$
- $Y_t = f_2(h_t^{(K)}; \theta)$
- $h_{-1}^{(k)}$ : initial states

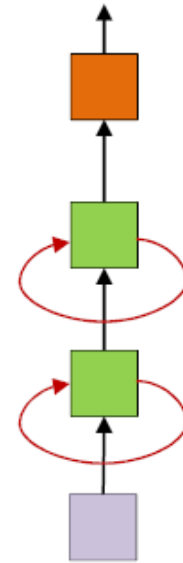

# Extensions

What if  $Y_t$  depends on the entire inputs?

- Birectional RNN:

- AN RNN for forward dependencies:  $t = 0, \dots, T$
- An RNN for backward dependencies:  $t = T, \dots, 0$

- $Y_t = f_2(h_t^f, h_t^b; \theta)$

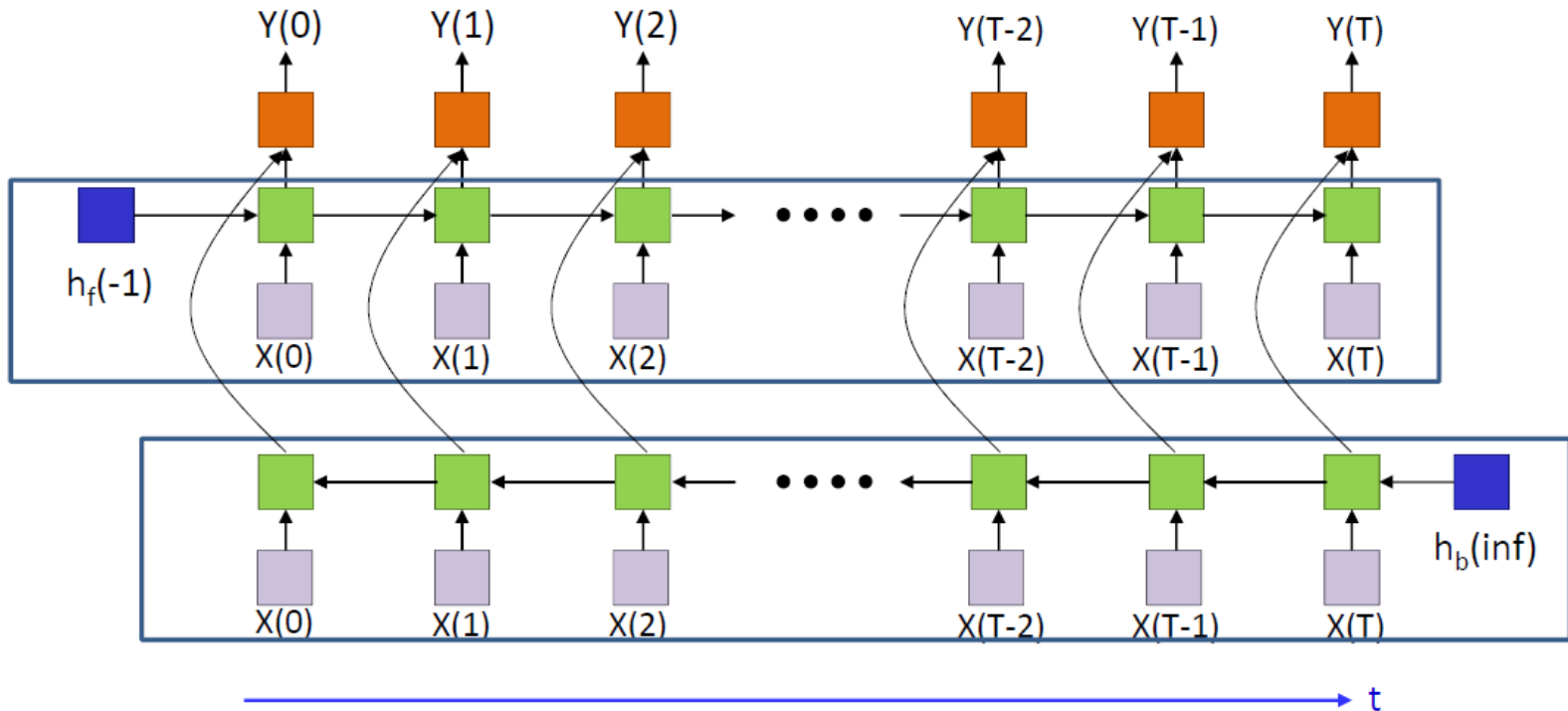

# Extensions

RNN for sequence classification (sentiment analysis)

- $Y = \max_t Y_t$
- Cross-entropy loss

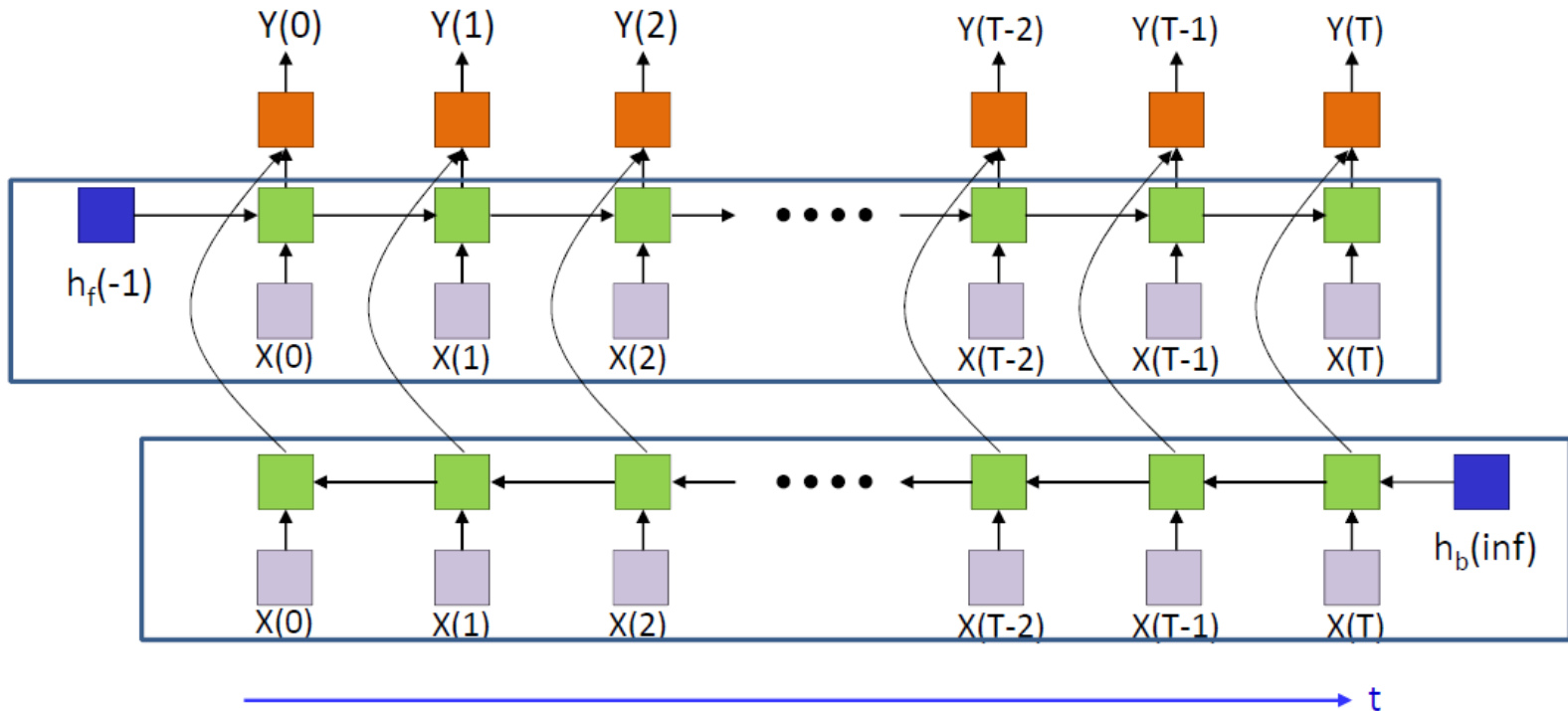

# Preserve Long-Term Memory

- Difficult for RNN to preserve long-term memory
  - The hidden state  $h_t$  is constantly being written (short-term memory)
  - Use a separate cell to maintain long-term memory

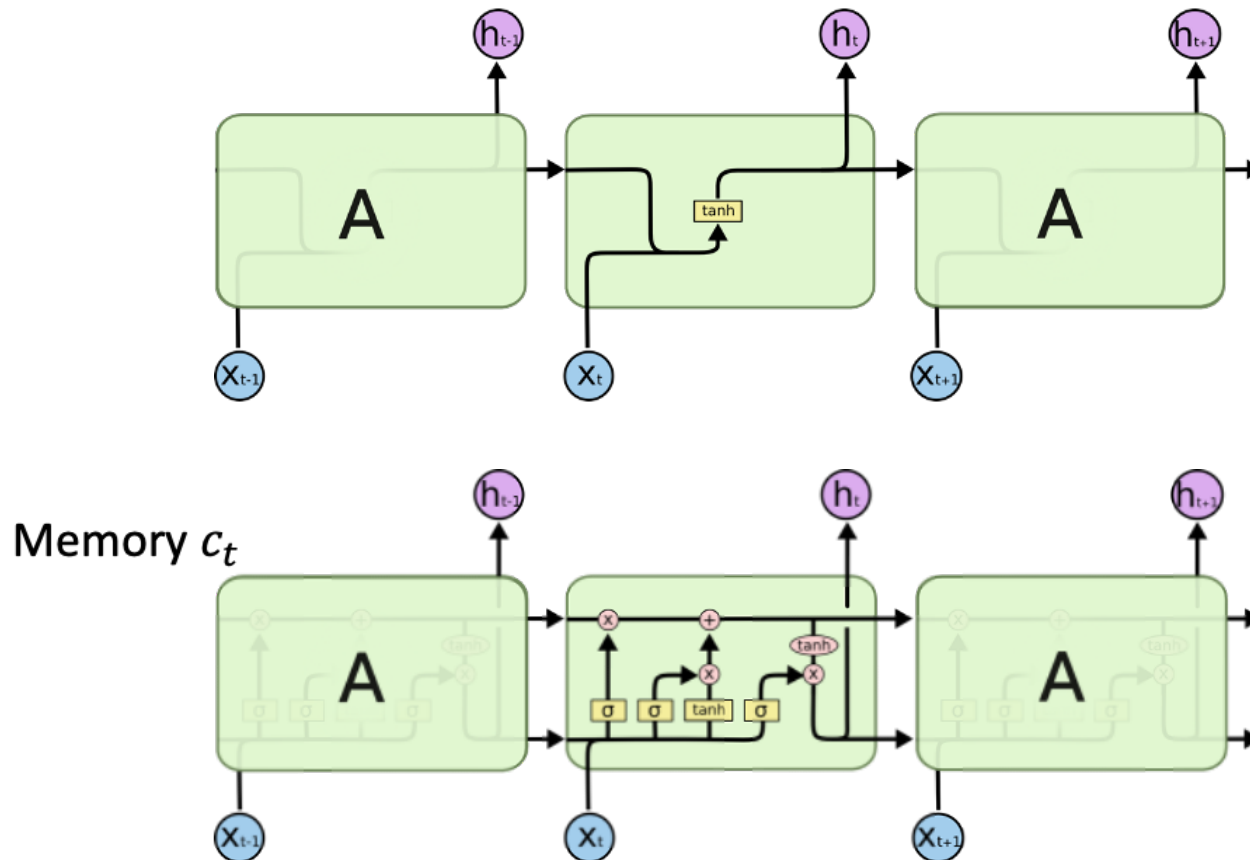

# Long Short-Term Memory Network

LSTM (Hochreiter & Schmidhuber, '97)

- RNN architecture for learning long-term dependencies
- $\sigma$ : layer with sigmoid activation

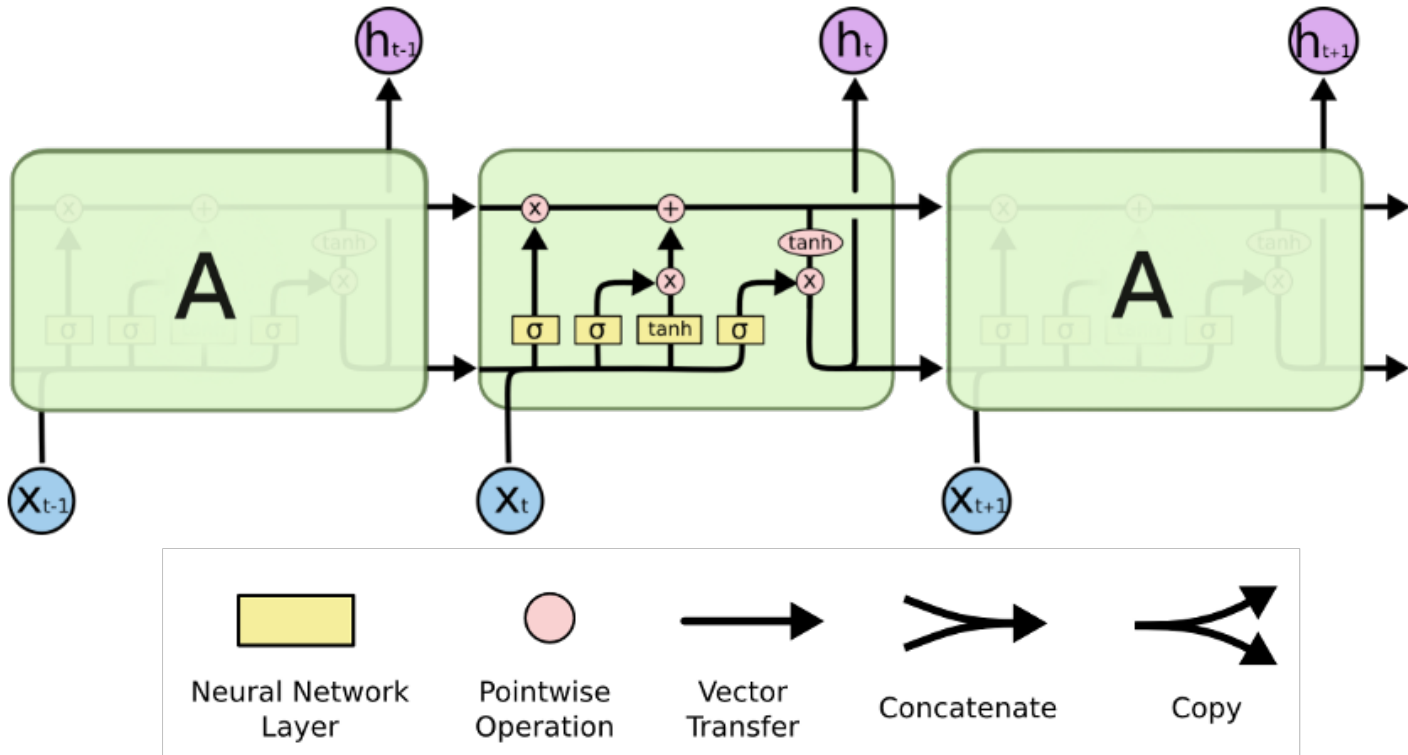

# Long Short-Term Memory Network

LSTM (Hochreiter & Schmidhuber, '97)

- Core idea: maintain separate state  $h_t$  and cell  $c_t$  (memory)
- $h_t$ : full update every step
- $c_t$ : only *partially* update through gates
  - $\sigma$  layer outputs importance ( $[0,1]$ ) for each entry and only modify those entries of  $c_t$

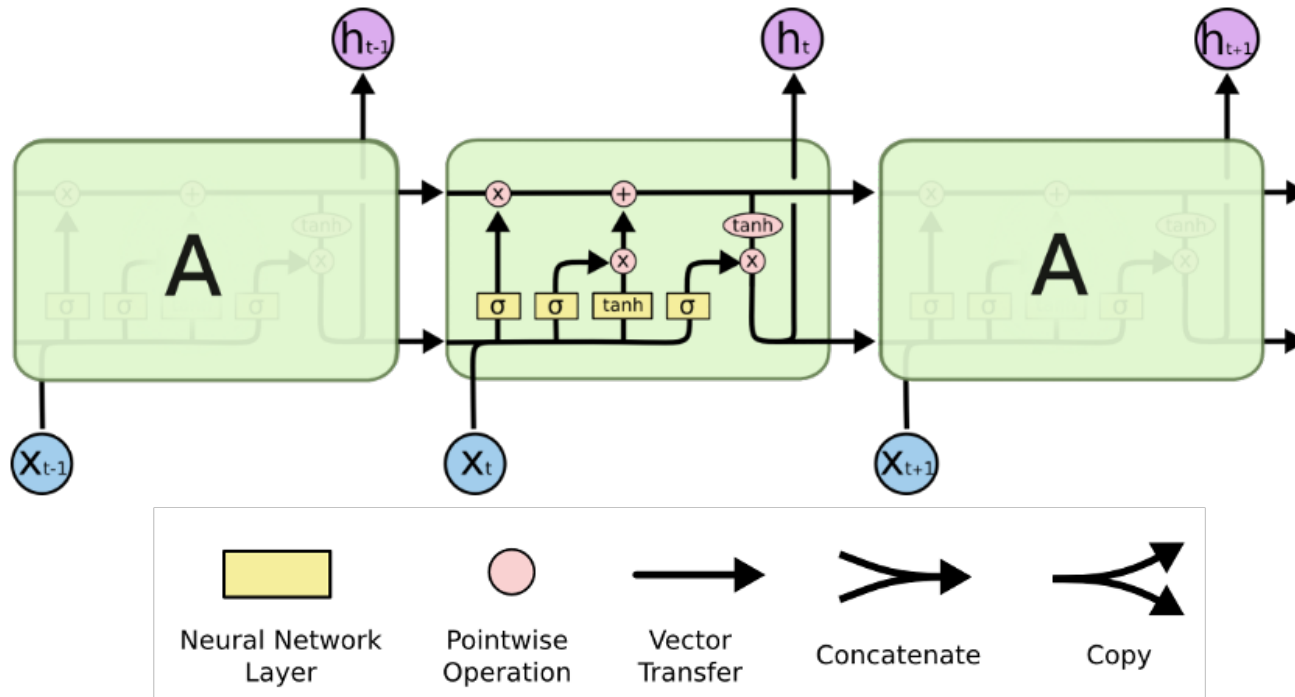

# Long Short-Term Memory Network

## Forget gate $f_t$

- $f_t$  outputs whether we want to “forget” things in  $c_t$ 
  - Compute  $c_{t-1} \odot f_t$  (element-wise)
  - $f_t(i) \rightarrow 0$ : want to forget  $c_t(i)$
  - $f_t(i) \rightarrow 1$ : we want to keep the information in  $c_t(i)$

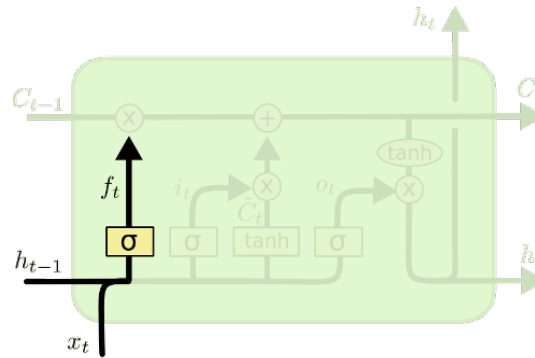
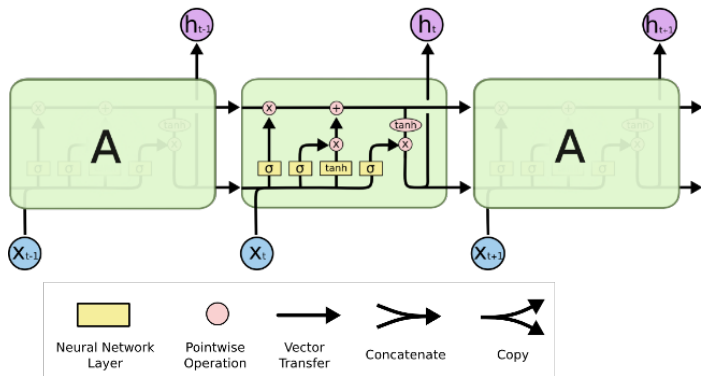

$$f_t = \sigma(W_f \cdot [h_{t-1}, x_t] + b_f)$$

# Long Short-Term Memory Network

## Input gate $i_t$

- $i_t$  extracts useful information from  $X_t$  to update memory
  - $\tilde{c}_t$ : information from  $X_t$  to update memory
  - $i_t$ : which dimension in the memory should be updated by  $X_t$ 
    - $i_t(j) \rightarrow 1$ : we want to use the information in  $\tilde{c}_t(j)$  to update memory
    - $i_t(j) \rightarrow 0$ :  $\tilde{c}_t(j)$  should not contribute to memory

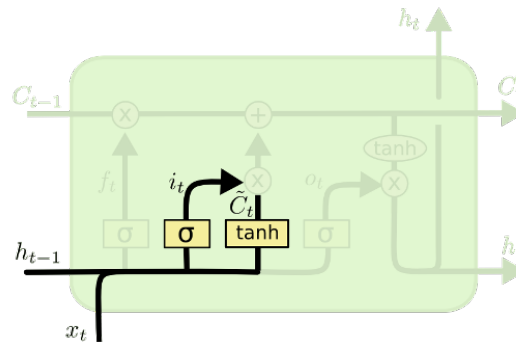
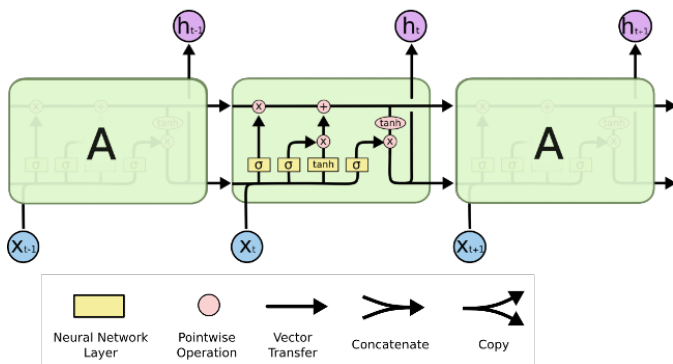

$$i_t = \sigma(W_i \cdot [h_{t-1}, x_t] + b_i)$$

$$\tilde{C}_t = \tanh(W_C \cdot [h_{t-1}, x_t] + b_C)$$

# Long Short-Term Memory Network

## Memory update

- $c_t = f_t \odot c_{t-1} + i_t \odot \tilde{c}_t$
- $f_t$  forget gate;  $i_t$  input gate
- $f_t \odot c_{t-1}$ : drop useless information in old memory
- $i_t \odot \tilde{c}_t$ : add selected new information from current input

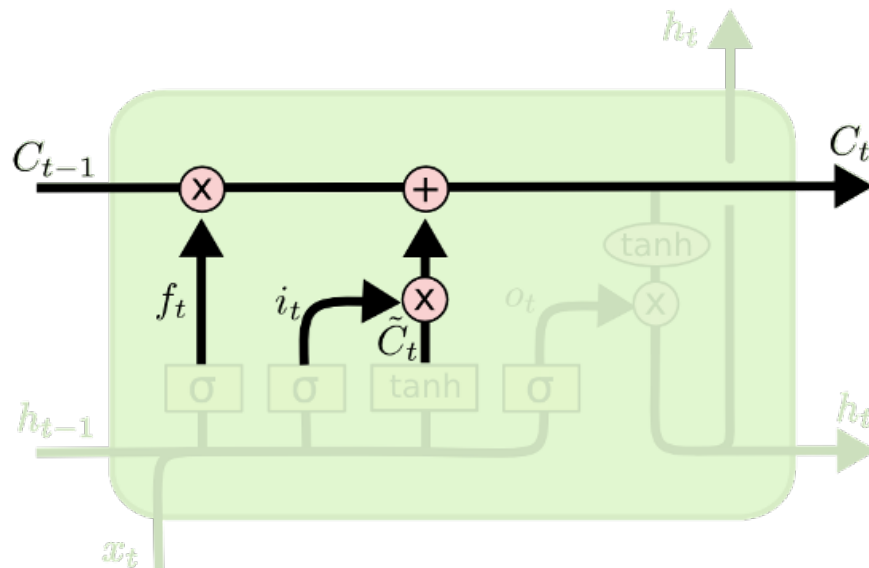

# Long Short-Term Memory Network

Output gate  $o_t$

- Next hidden state  $h_t = o_t \odot \tanh(c_t)$ 
  - $\tanh(c_t)$ : non-linear transformation over all past information
  - $o_t$ : choose important dimensions for the next state
    - $o_t(j) \rightarrow 1$  :  $\tanh(c_t(j))$  is important for the next state
    - $o_t(j) \rightarrow 0$  :  $\tanh(c_t(j))$  is not important

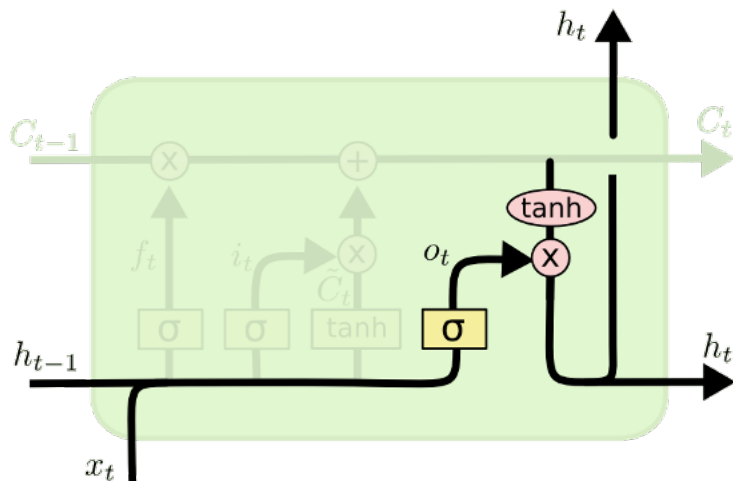

$$o_t = \sigma (W_o [h_{t-1}, x_t] + b_o)$$

$$h_t = o_t * \tanh (C_t)$$

# Long Short-Term Memory Network

- $h_t = o_t \odot \tanh(c_t)$
- $c_t = f_t \odot c_{t-1} + i_t \odot \tilde{c}_t$
- $Y_t = g(h_t)$

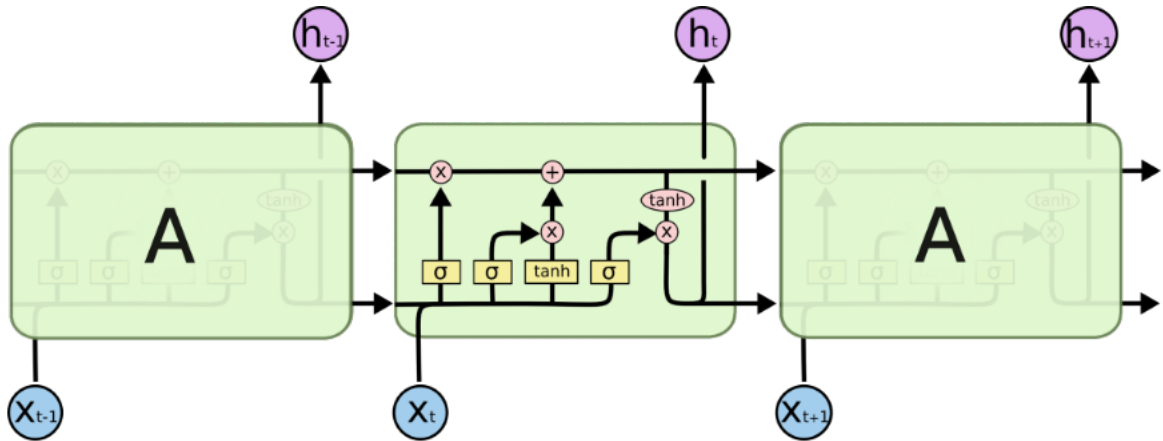

Remarks:

1. No more matrix multiplications for  $c_t$
2. LSTM does not have guarantees for gradient explosion/vanishing
3. LSTM is the dominant architecture for sequence modeling from '13 - '16.
4. Why tanh

# LSTM Variant

Peephole Connections (Gers & Schmidhuber '00)

- Allow gates to take in  $c_t$  information

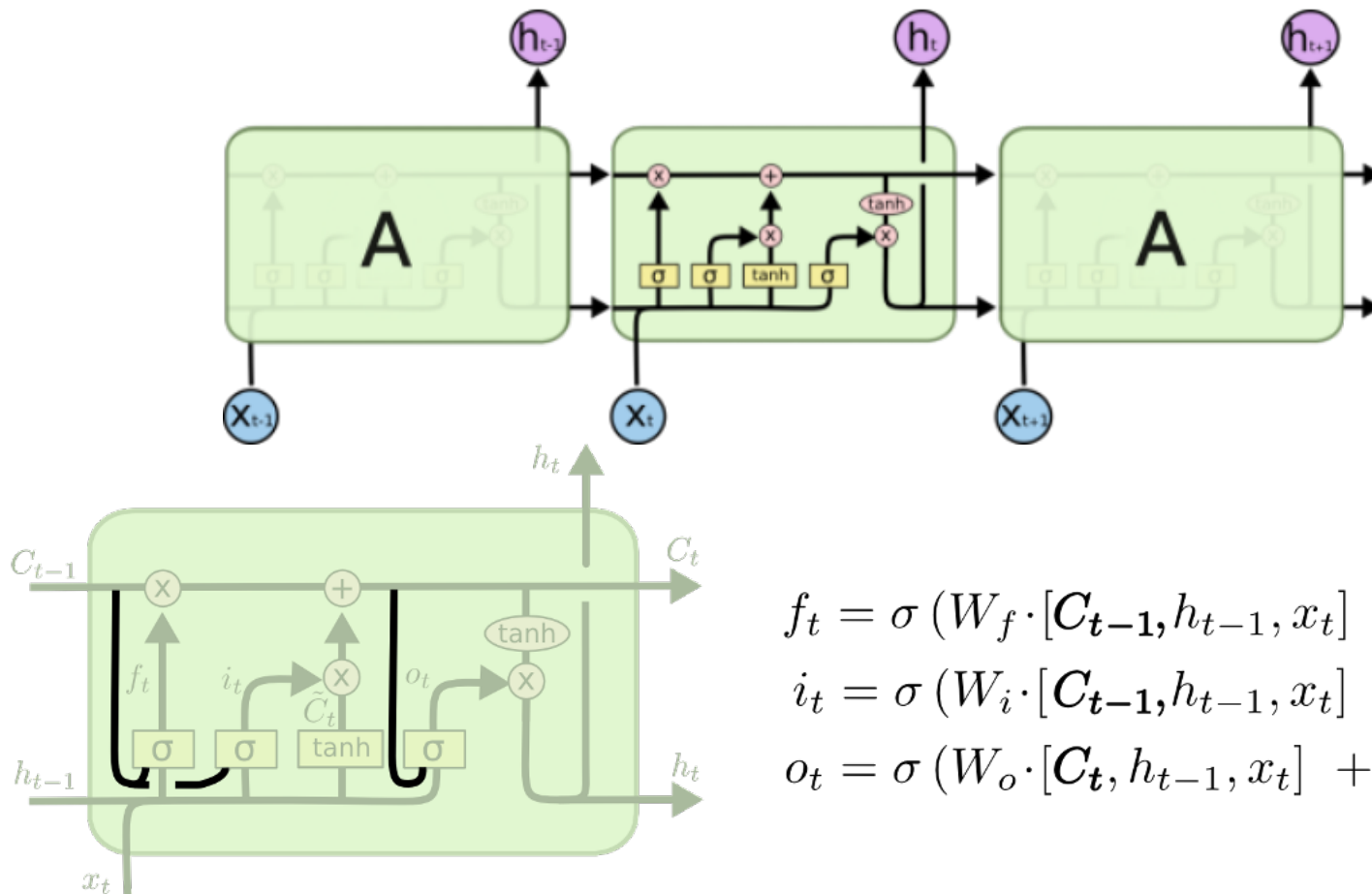

$$f_t = \sigma(W_f \cdot [C_{t-1}, h_{t-1}, x_t] + b_f)$$

$$i_t = \sigma(W_i \cdot [C_{t-1}, h_{t-1}, x_t] + b_i)$$

$$o_t = \sigma(W_o \cdot [C_t, h_{t-1}, x_t] + b_o)$$

# LSTM Variant

## Simplified LSTM

- Assume  $i_t = 1 - f_t$
- Only two gates are needed: fewer parameters

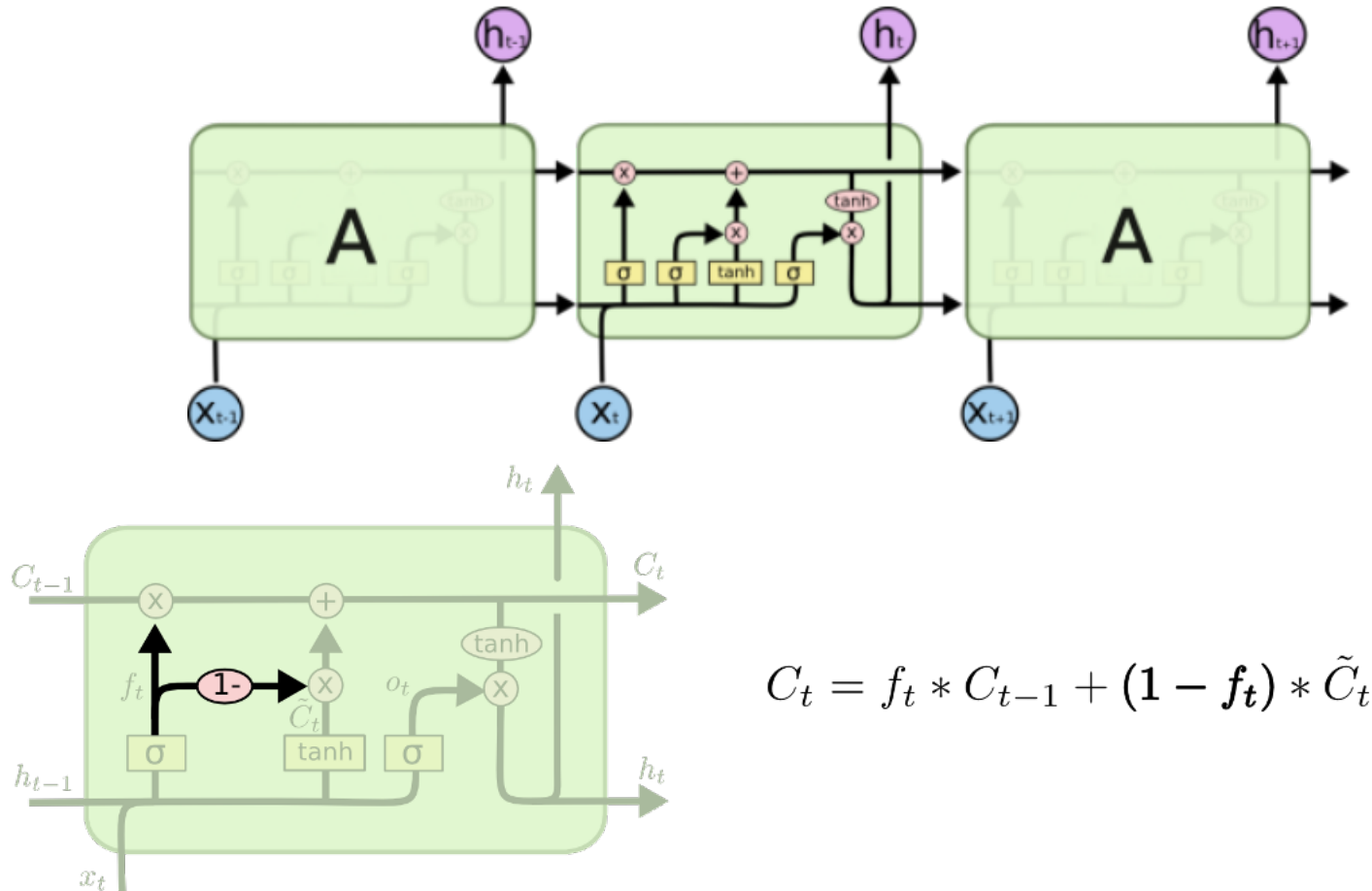

$$C_t = f_t * C_{t-1} + (1 - f_t) * \tilde{C}_t$$

# LSTM Variant

Gated Recurrent Unit (GRU, Cho et al. '14)

- Merge  $h_t$  and  $c_t$ : much fewer parameters

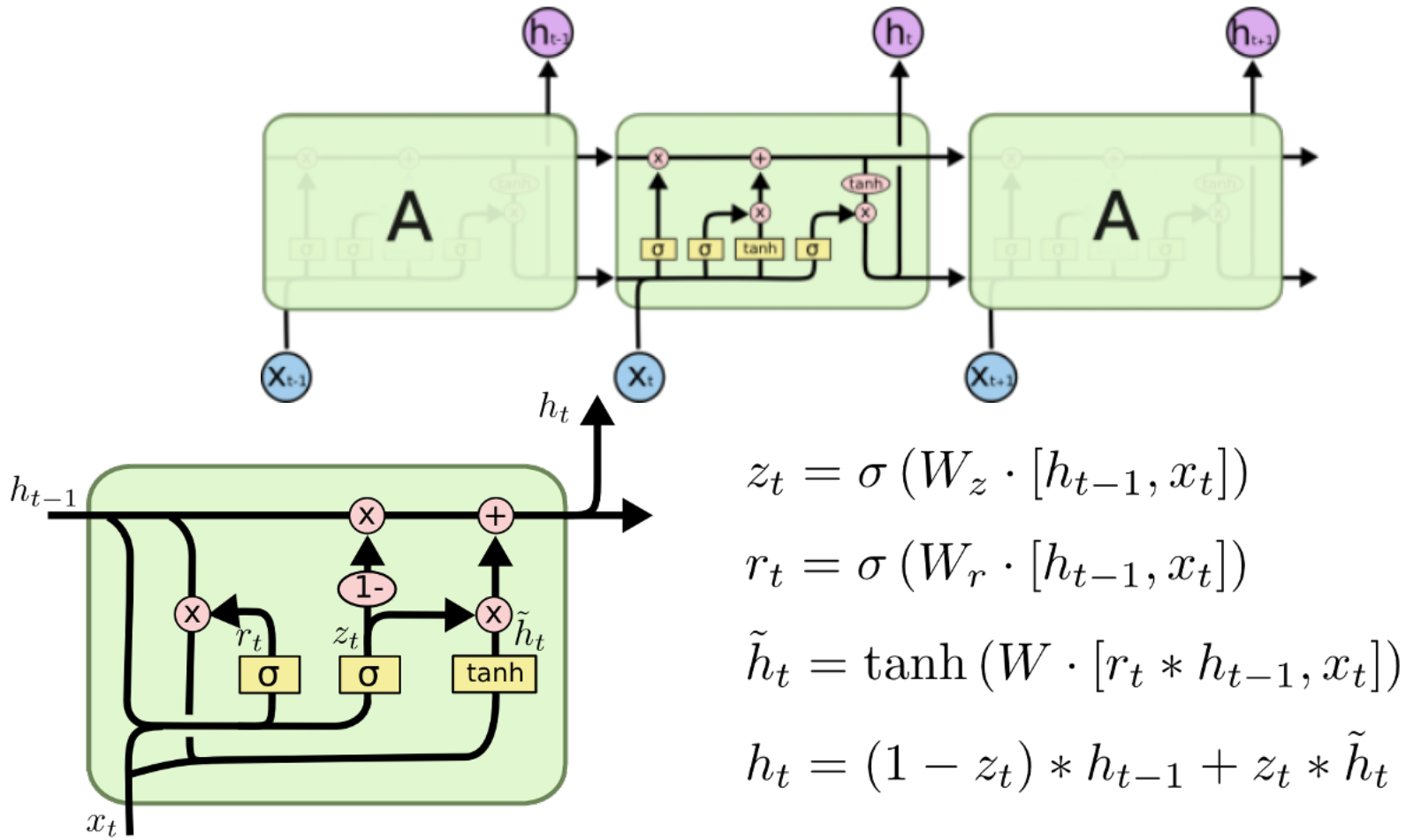

$$z_t = \sigma(W_z \cdot [h_{t-1}, x_t])$$

$$r_t = \sigma(W_r \cdot [h_{t-1}, x_t])$$

$$\tilde{h}_t = \tanh(W \cdot [r_t * h_{t-1}, x_t])$$

$$h_t = (1 - z_t) * h_{t-1} + z_t * \tilde{h}_t$$

# LSTM application: language model

- Autoregressive language model:  $P(X; \theta) = \prod_{t=1}^L P(X_t | X_{i < t}; \theta)$ 
  - $X$ : a sentence
  - Sequential generation
- LSTM language model
  - $X_t$ : word at position  $t$ .
  - $Y_t$ : softmax over all words
- Data: a collection of texts:
  - Wiki

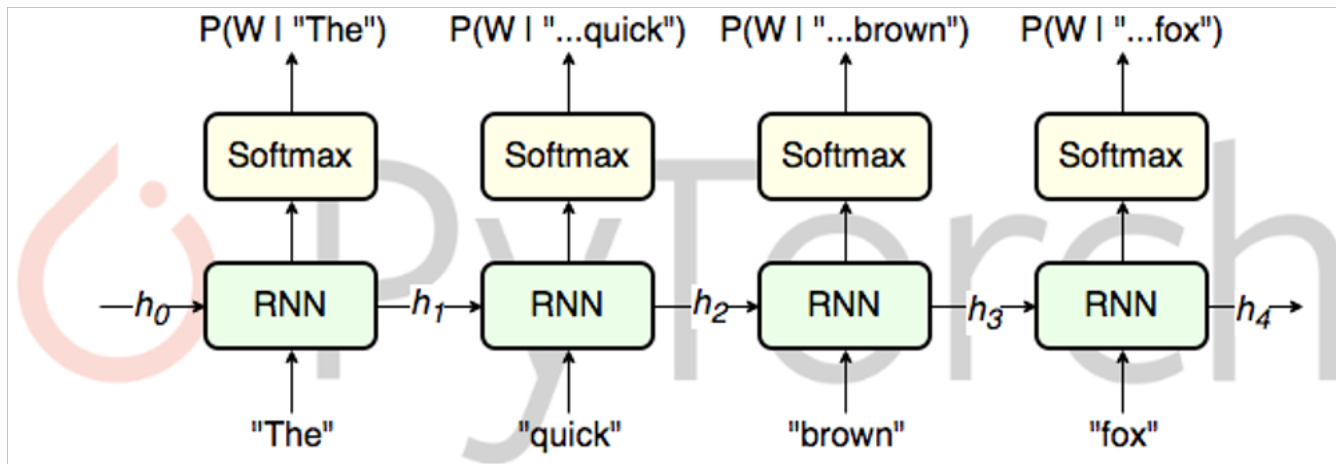

# Attention Mechanism

---



# Machine Translation

---

- Before 2014: Statistical Machine Translation (SMT)
  - Extremely complex systems that require massive human efforts
  - Separately designed components
  - A lot of feature engineering
  - Lots of linguistic domain knowledge and expertise
- Before 2016:
  - Google Translate is based on statistical machine learning
- What happened in 2014?
  - Neural machine translation (NMT)

# Sequence to Sequence Model

---

- Neural Machine Translation (NMT)
  - Learning to translate via a **single end-to-end** neural network.
  - Source language sentence  $X$ , target language sentence  $Y = f(X; \theta)$
- Sequence to Sequence Model (Seq2Seq, Sutskever et al. , '14)
  - Two RNNs:  $f_{enc}$  and  $f_{dec}$
  - Encoder  $f_{enc}$ :
    - Takes  $X$  as input, and output the initial hidden state for decoder
    - Can use bidirectional RNN
  - Decoder  $f_{dec}$ :
    - It takes in the hidden state from  $f_{enc}$  to generate  $Y$
    - Can use autoregressive language model

# Sequence to Sequence Model

## The sequence-to-sequence model

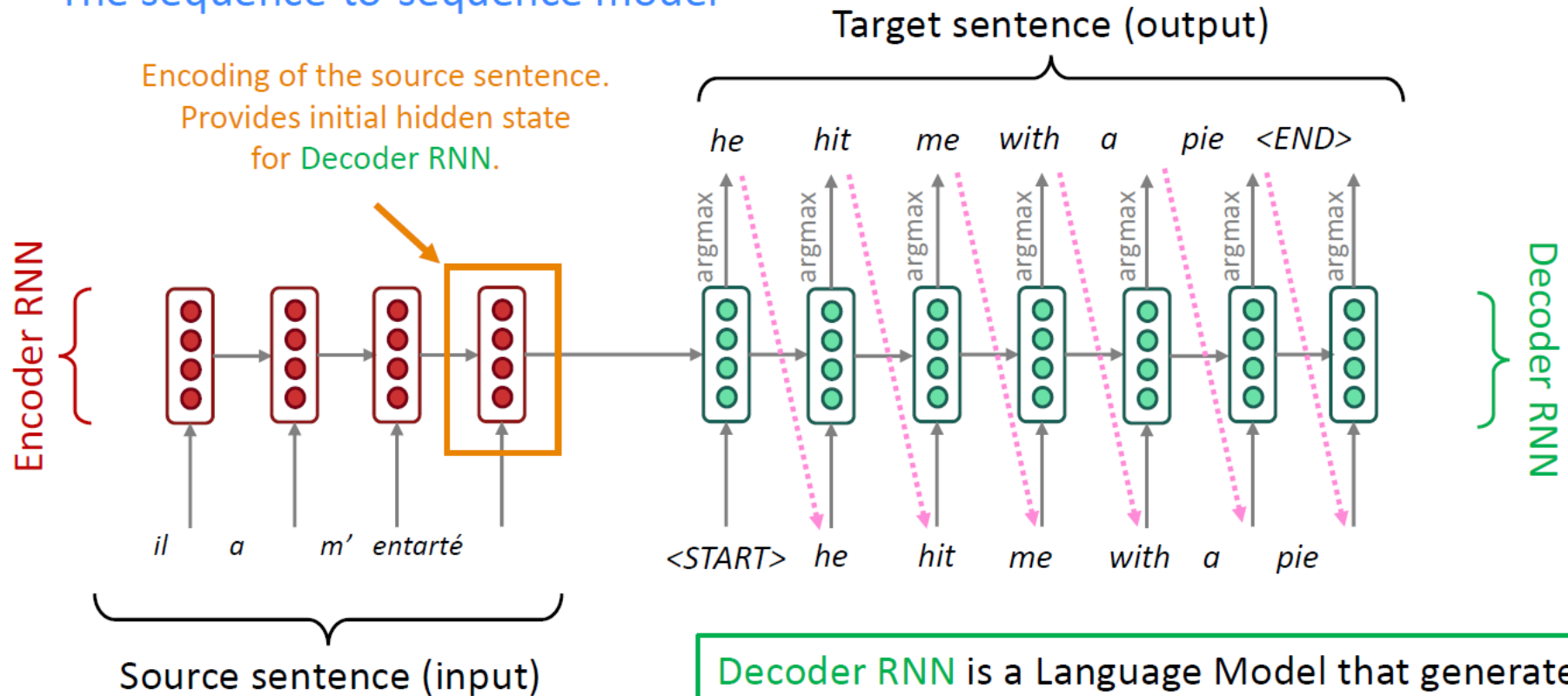

Encoding of the source sentence.  
Provides initial hidden state  
for Decoder RNN.

Encoder RNN

il a m' entarté

Source sentence (input)

Target sentence (output)

he hit me with a pie <END>

argmax argmax argmax argmax argmax argmax argmax

<START> he hit me with a pie

Decoder RNN

Decoder RNN is a Language Model that generates target sentence, *conditioned on encoding*.

Encoder RNN produces an **encoding** of the source sentence.

Note: This diagram shows **test time** behavior: decoder output is fed in **as next step's input**

# Training Sequence to Sequence Model

- Collect a huge paired dataset and train it end-to-end via BPTT
- Loss induced by MLE  $P(Y|X) = P(Y|f_{enc}(X))$

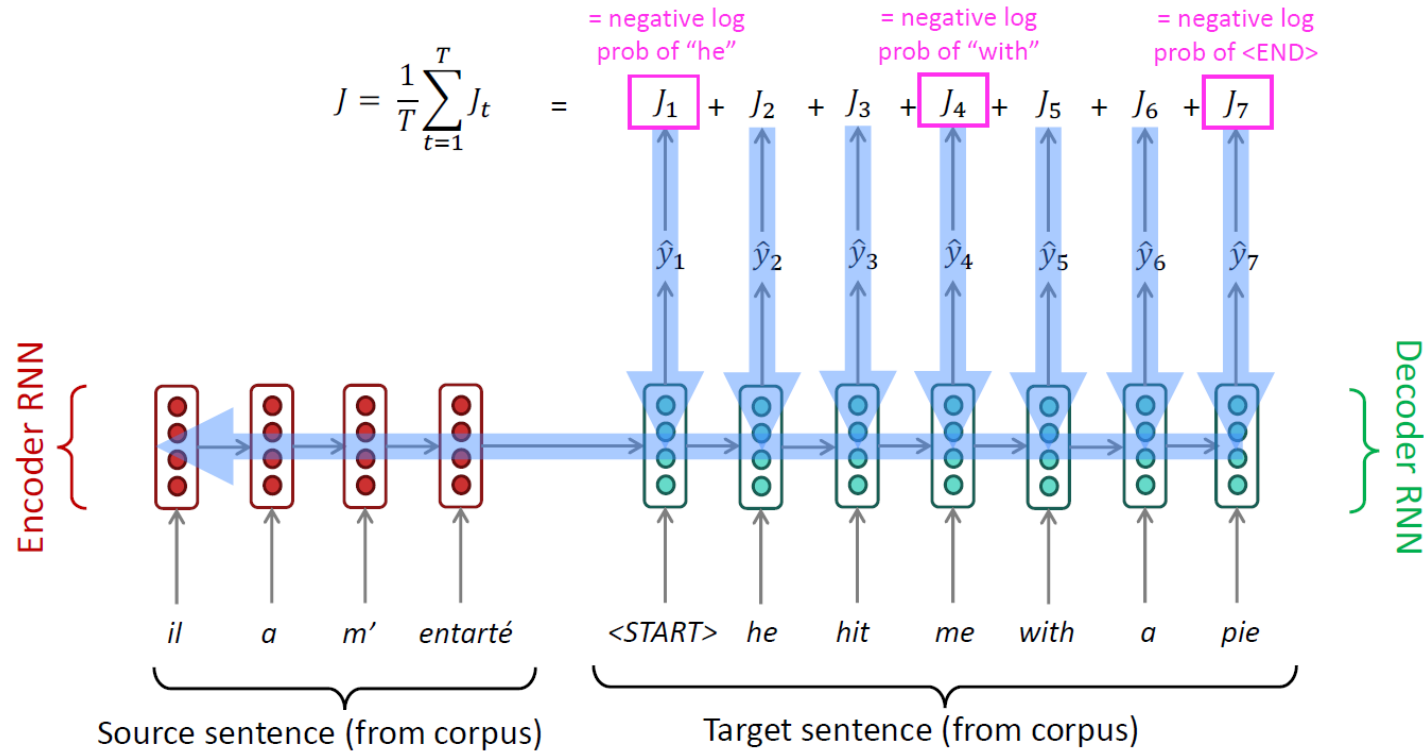

Seq2seq is optimized as a **single system**. Backpropagation operates "*end-to-end*".

# Deep Sequence to Sequence Model

- Stacked seq2seq model

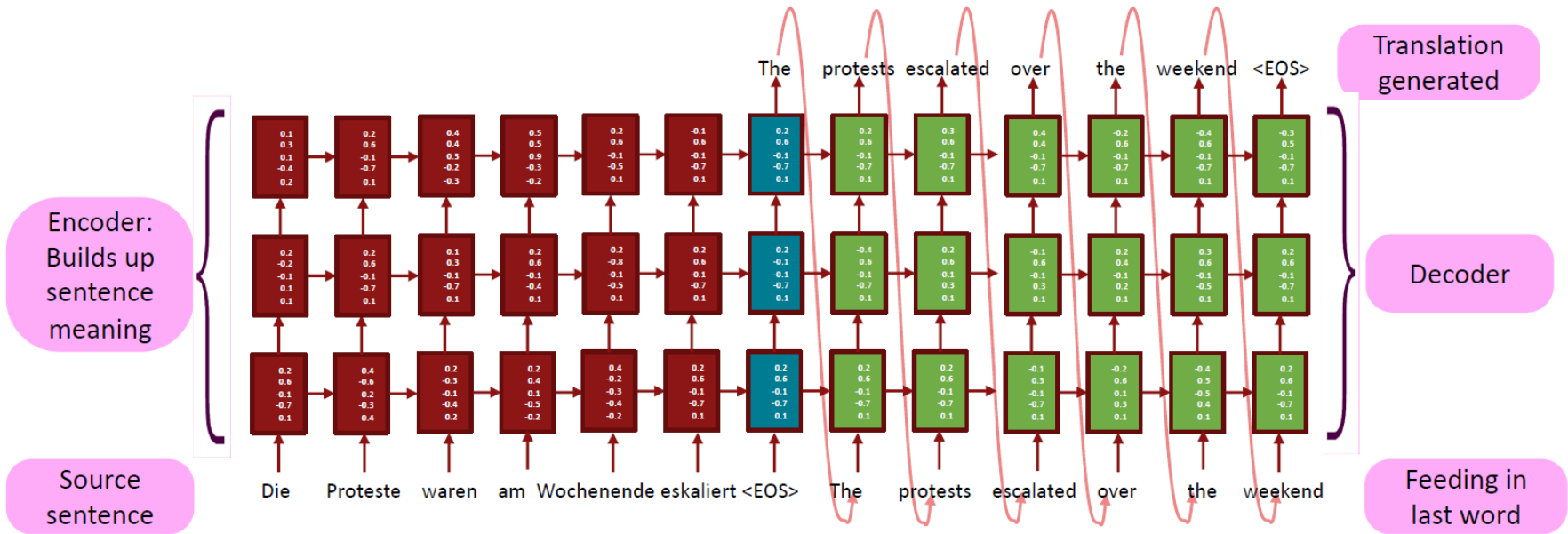

# Machine Translation

- 2016: Google switched Google Translate from SMT to NMT

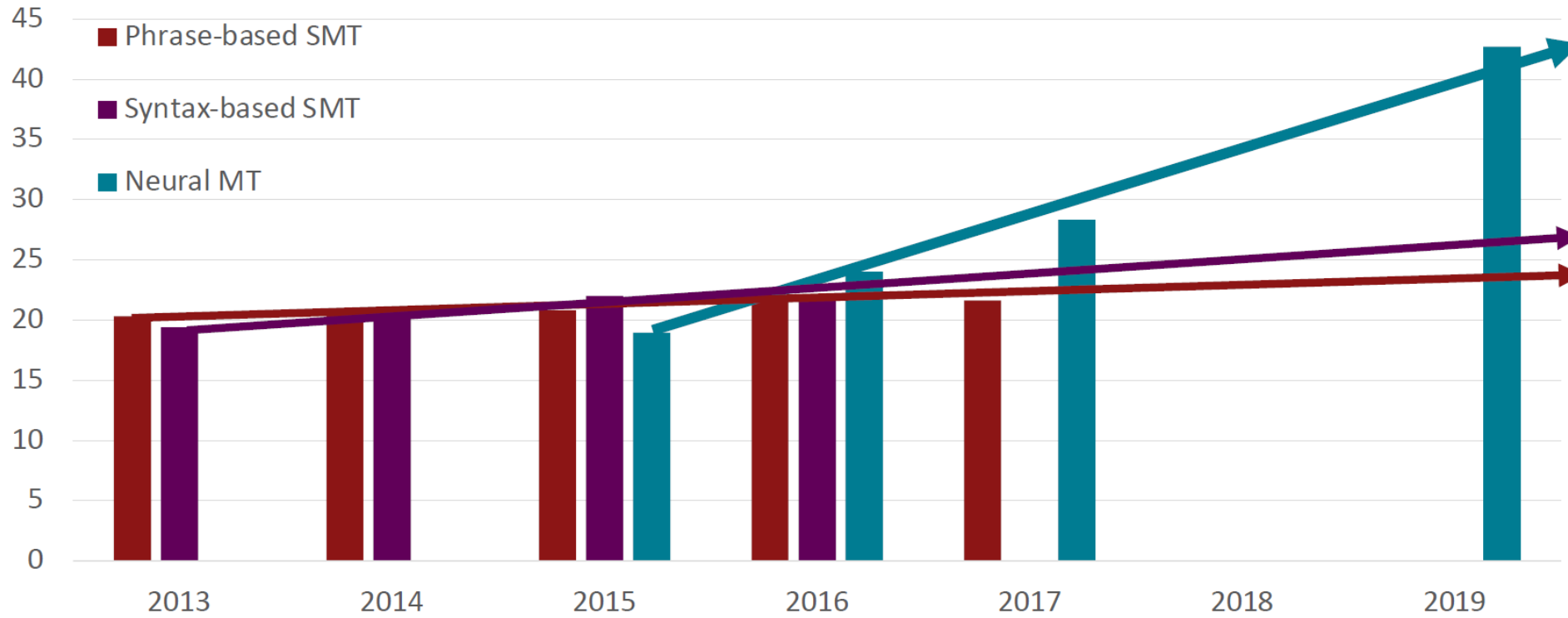

# Alignment

- Alignment: the word-level correspondence between X and Y
- Can have complex long-term dependencies

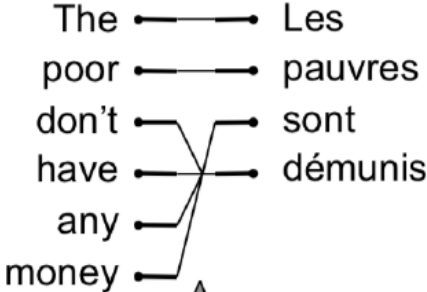
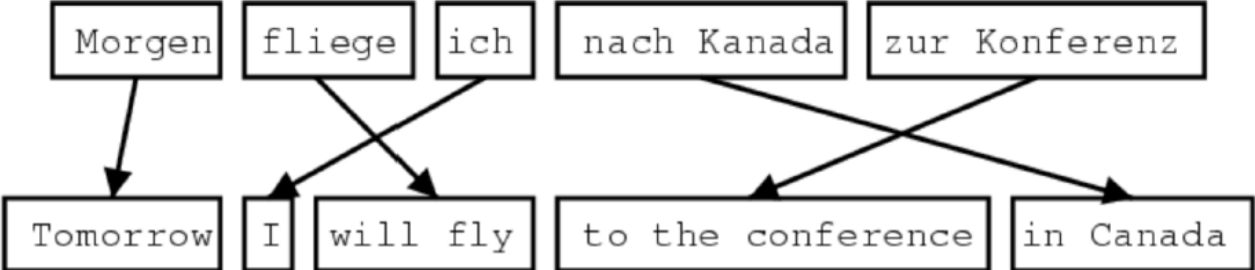

many-to-many alignment

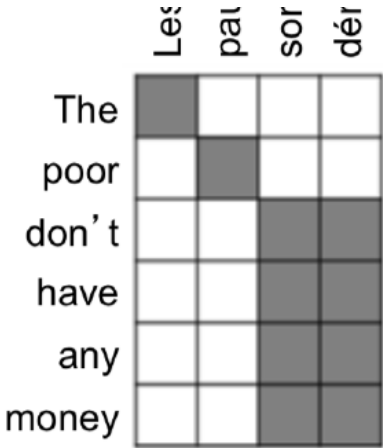

phrase alignment

# Issue in Seq2Seq

- Alignment: the word-level correspondence between  $X$  and  $Y$ 
  - The information bottleneck due to the hidden state  $h$
  - We want each  $Y_t$  to also focus on some  $X_i$  that it is aligned with

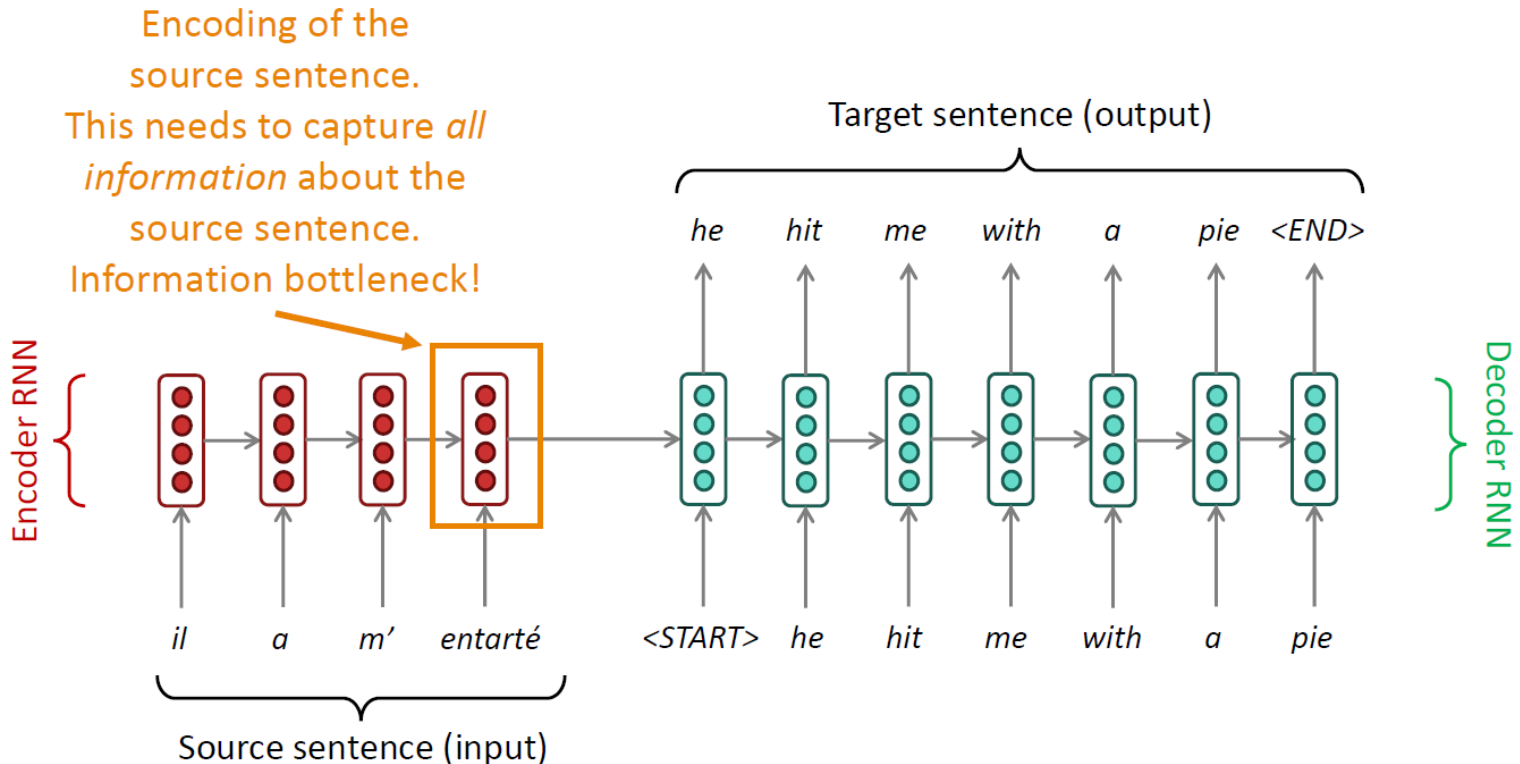

# Seq2Seq with Attention

---

- NMT by jointly learning to align and translate (Bahdanau, Cho, Bengio, '15)
- Core idea:
  - When decoding  $Y_t$ , consider both hidden states and alignment:
    - Hidden state:  $h_t = f_{dec}(Y_{i<t})$
    - Alignment: connect to a portion of  $X$
  - When portion of  $X$  to focus on?
    - Learn a softmax weight over  $X$ : attention distribution  $P_{att}$
    - $P_{att}(X_i | h_t)$ : how much attention to put on word  $X_i$
    - Attention output  $h_{att} = \sum_i f_{enc}(X_i | X_{j<i}) \cdot P_{att}(X_i | h_{t-1})$
    - Use  $h_{t-1}$  and  $h_{att}$  to compute  $Y_t$

# Seq2Seq with Attention

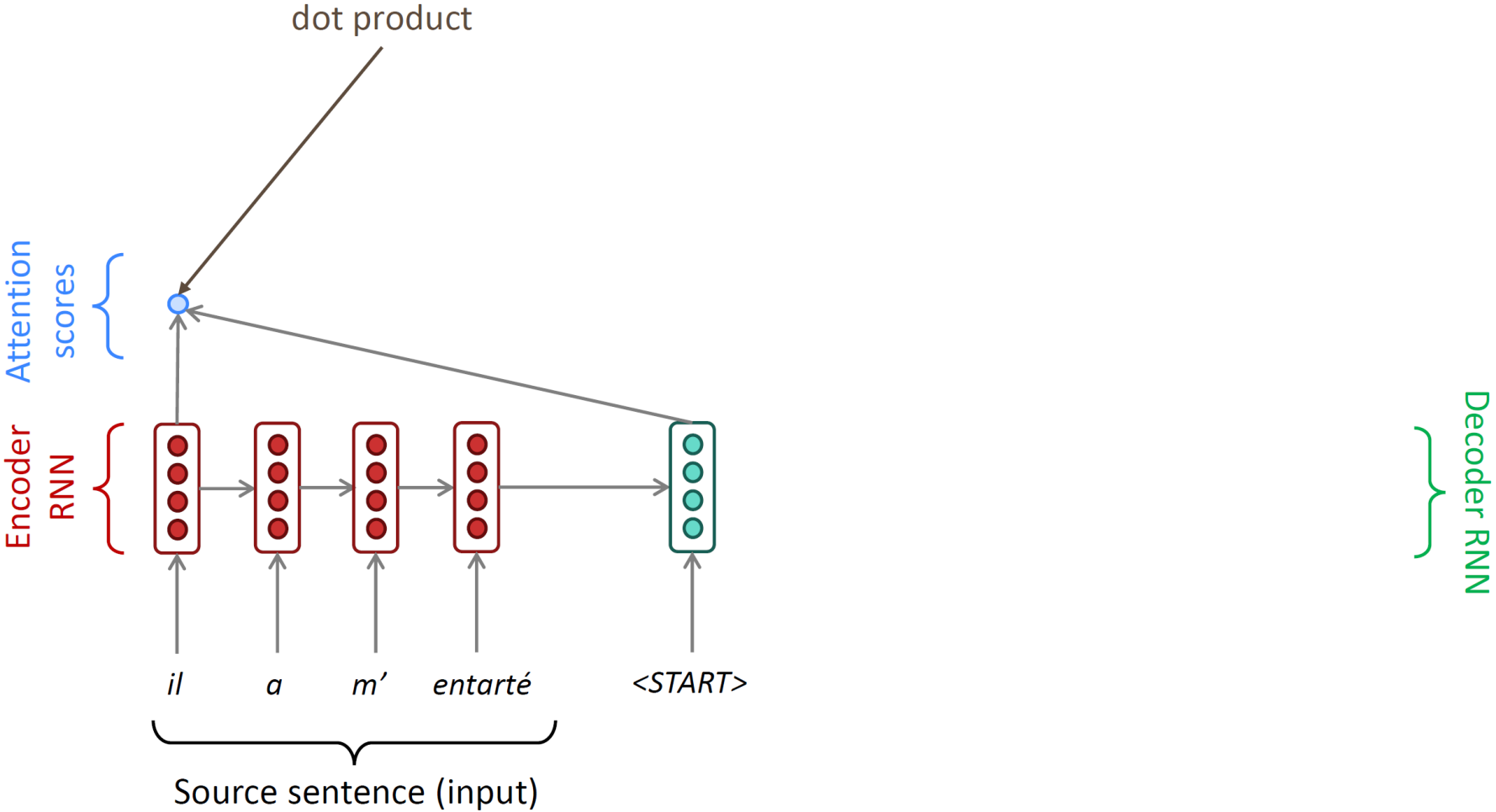

# Seq2Seq with Attention

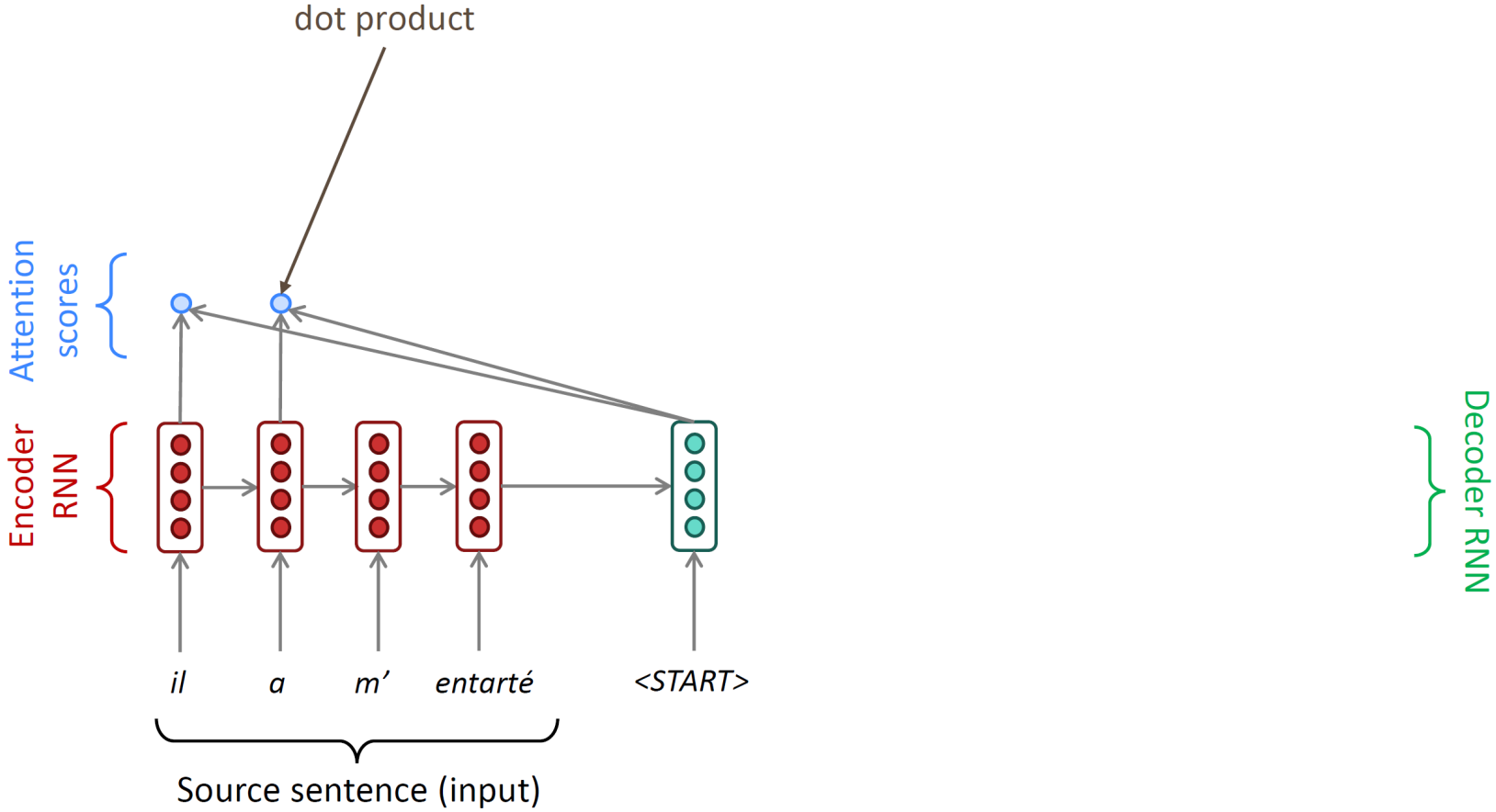

# Seq2Seq with Attention

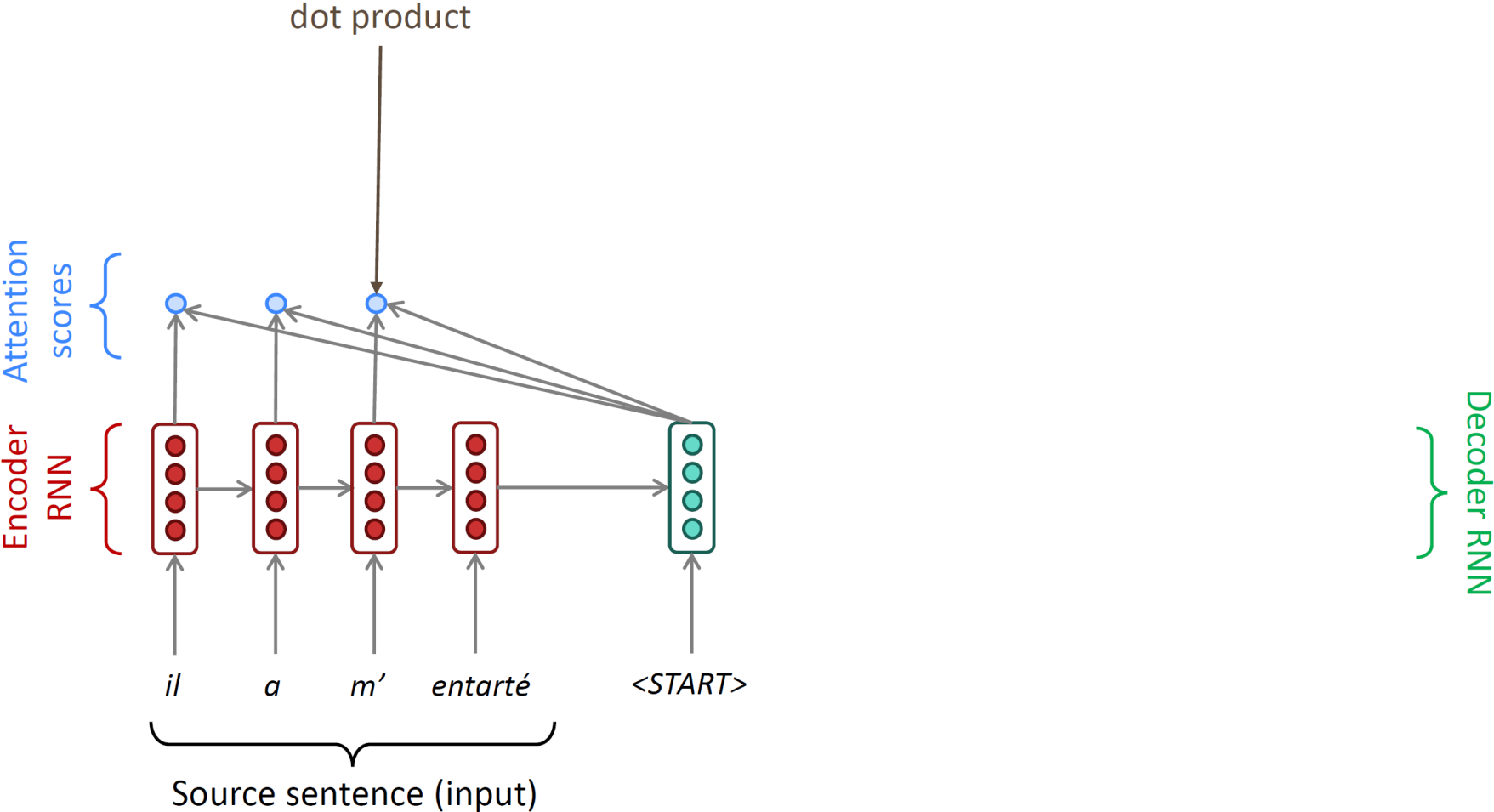

# Seq2Seq with Attention

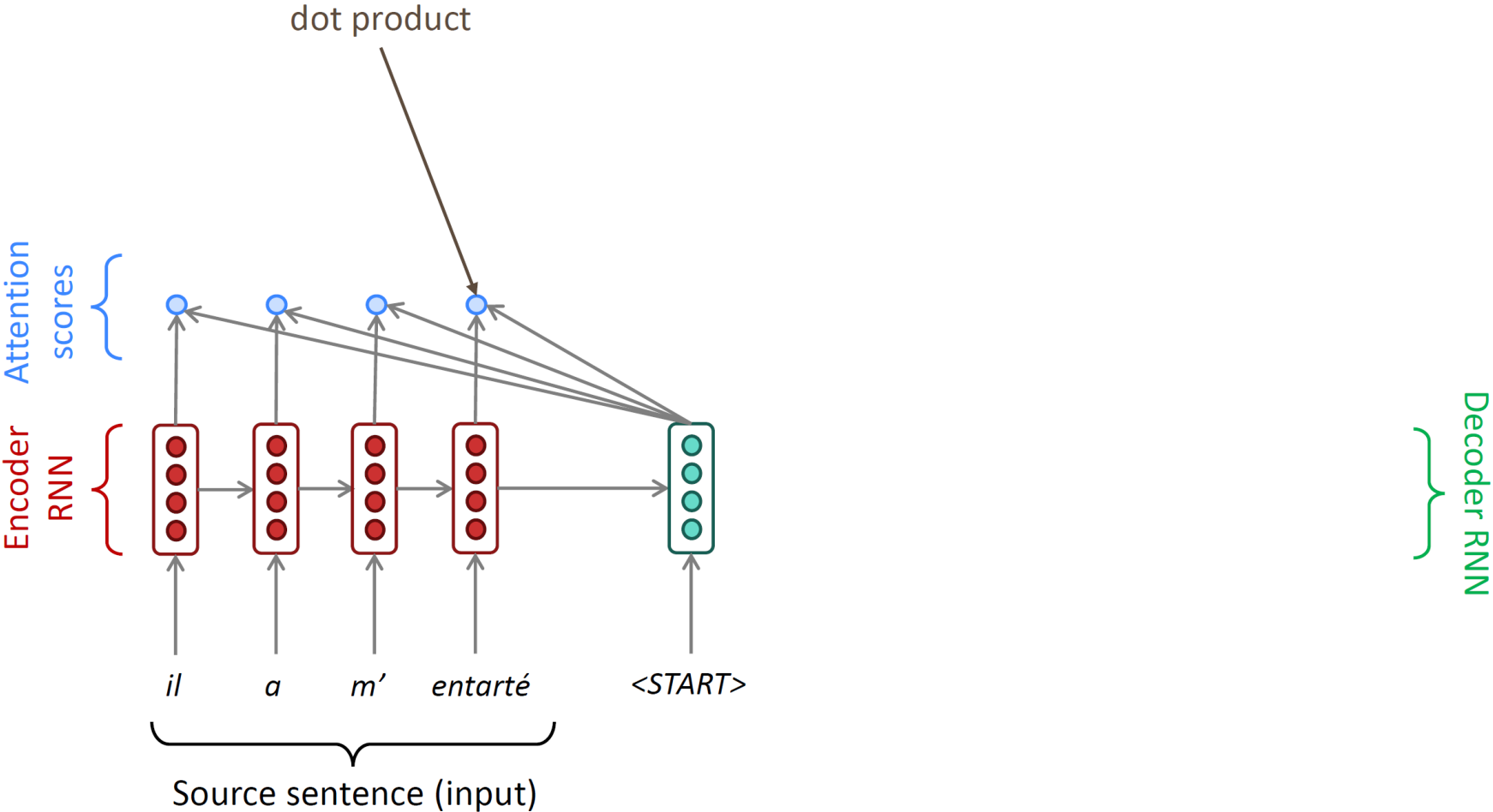

# Seq2Seq with Attention

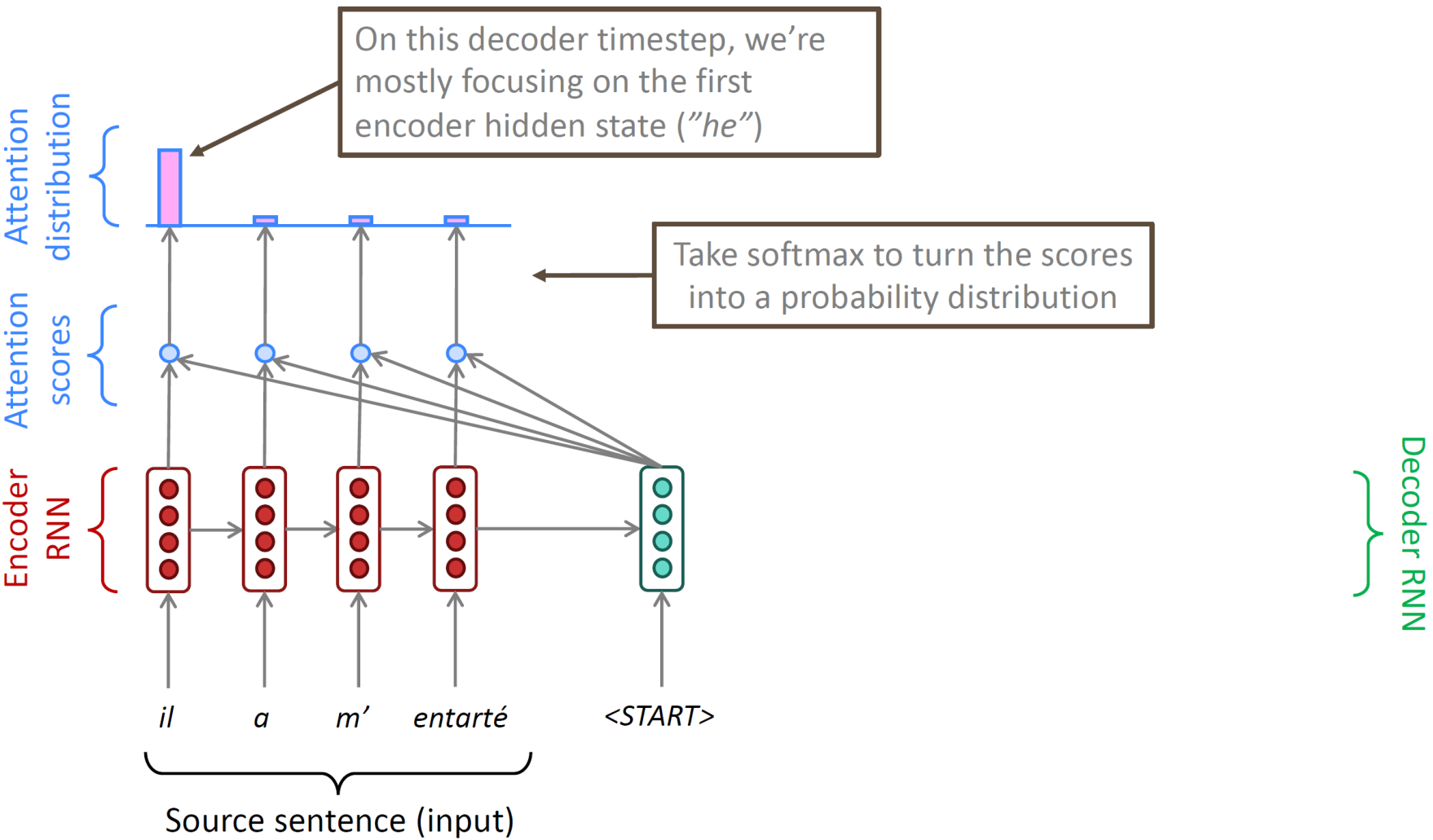

# Seq2Seq with Attention

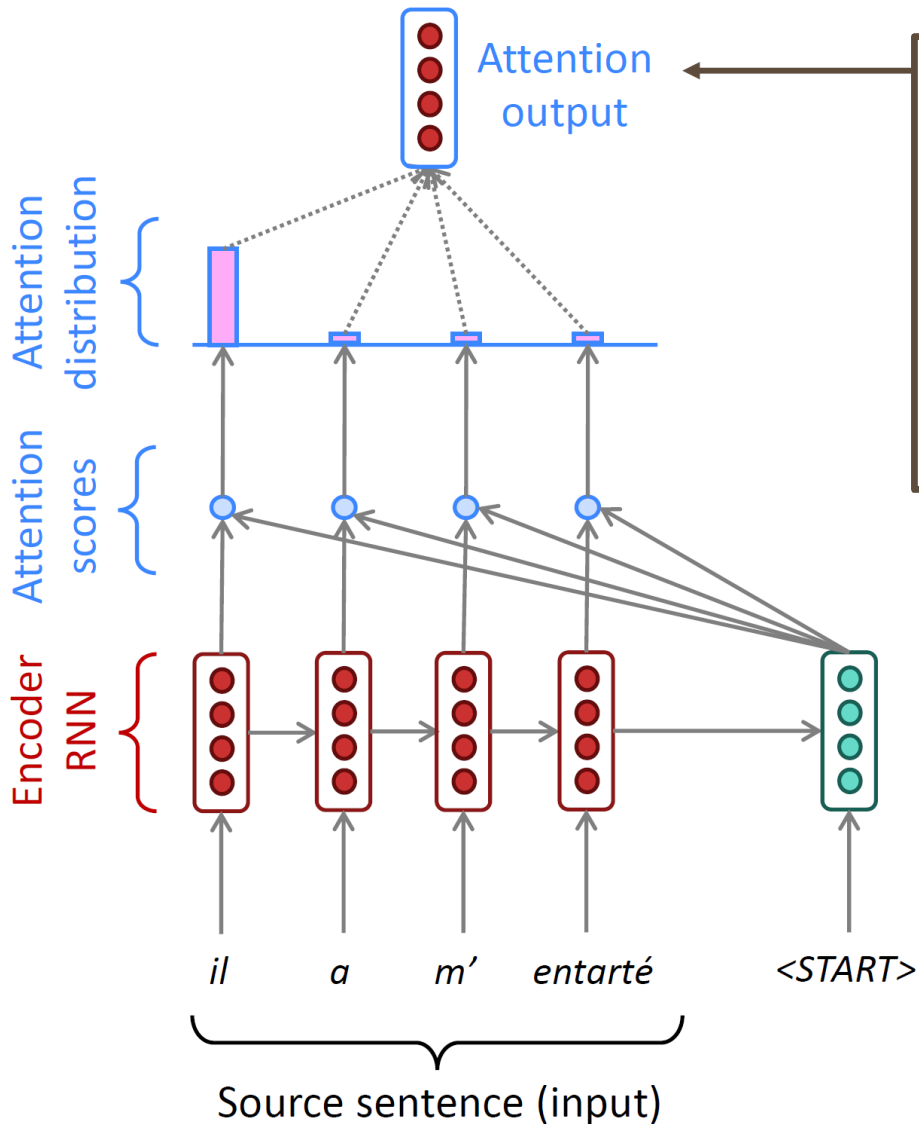

Use the attention distribution to take a **weighted sum** of the **encoder hidden states**.

The attention output mostly contains information from the **hidden states** that received **high attention**.

Decoder RNN

# Seq2Seq with Attention

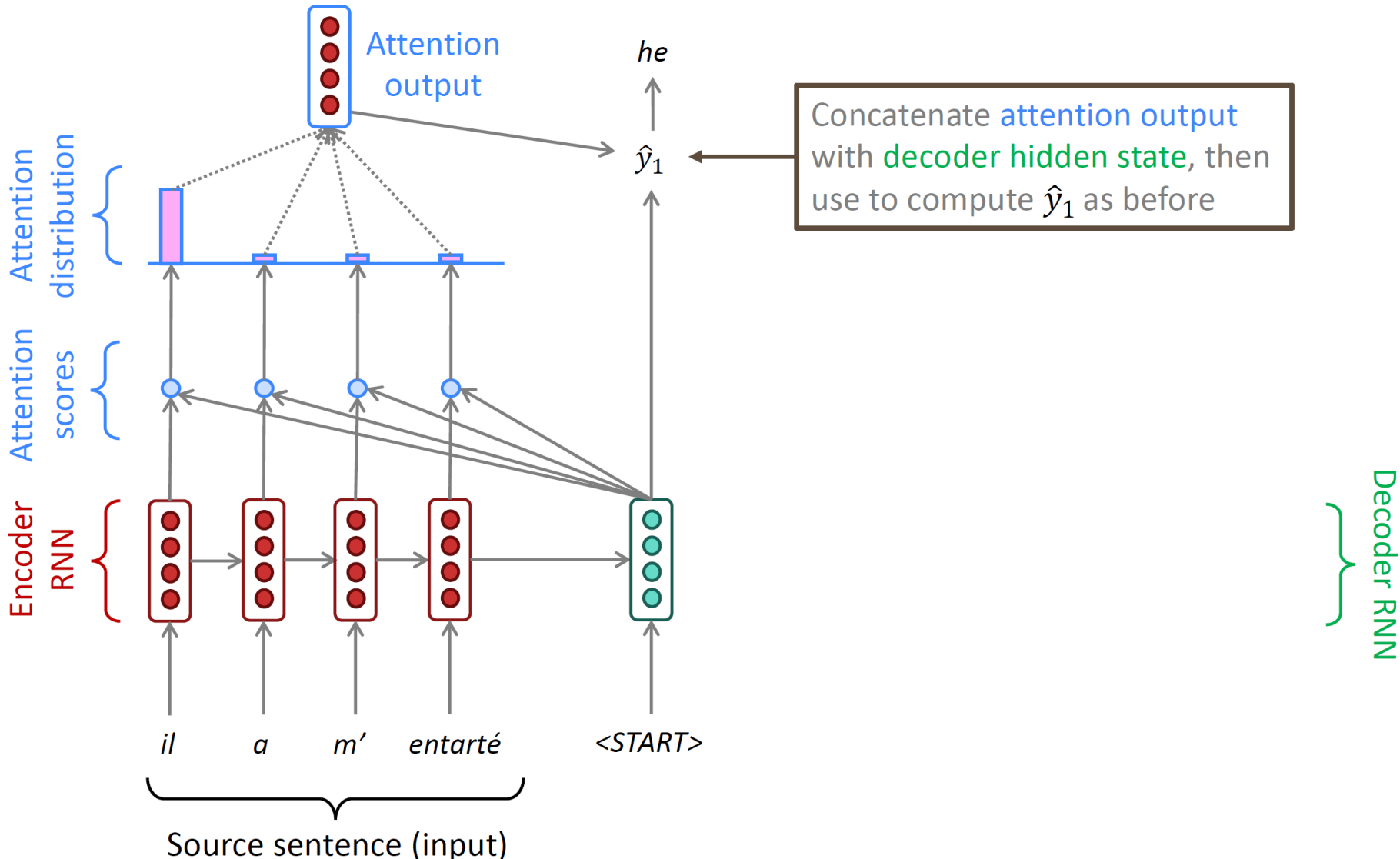

# Seq2Seq with Attention

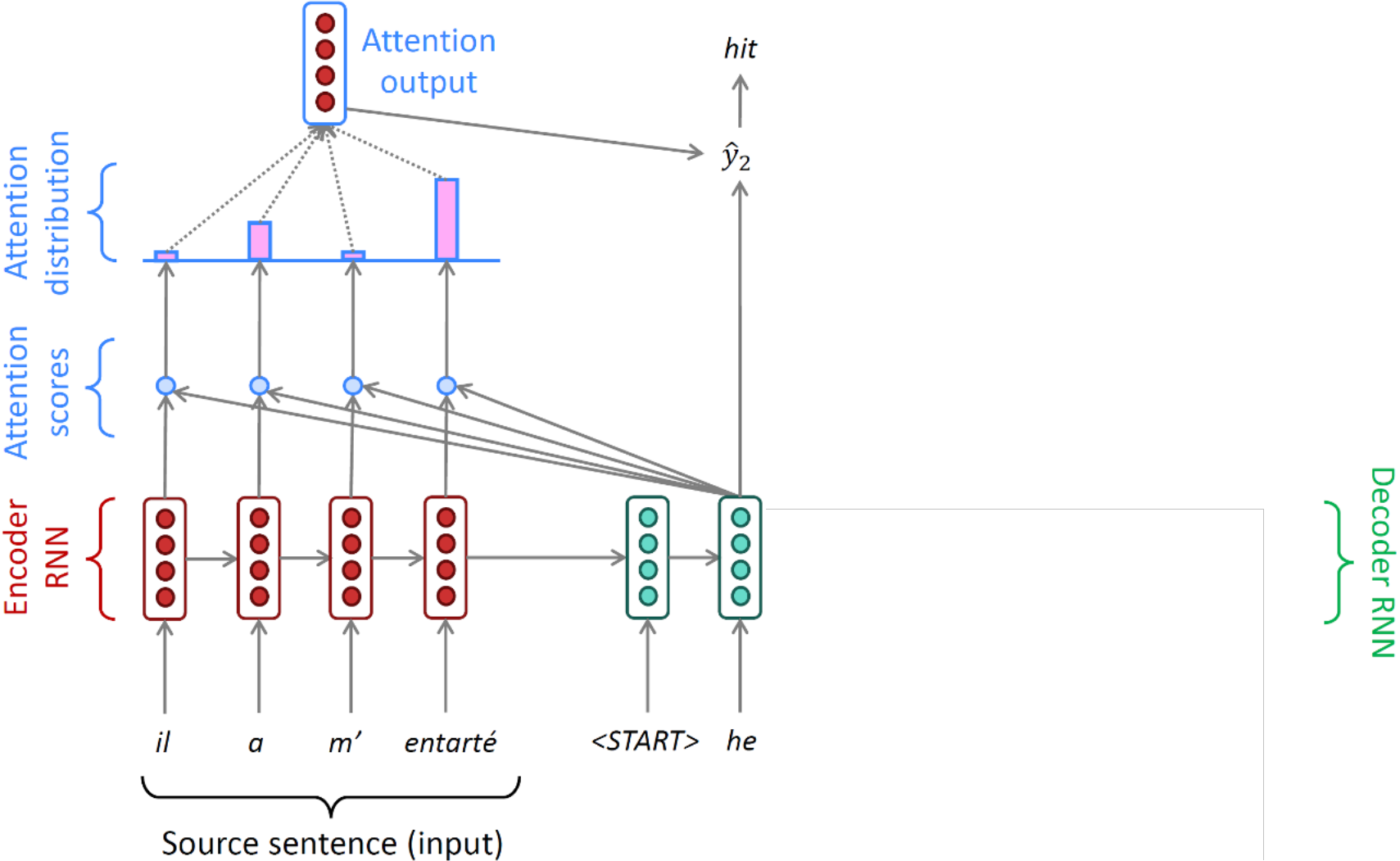

# Seq2Seq with Attention

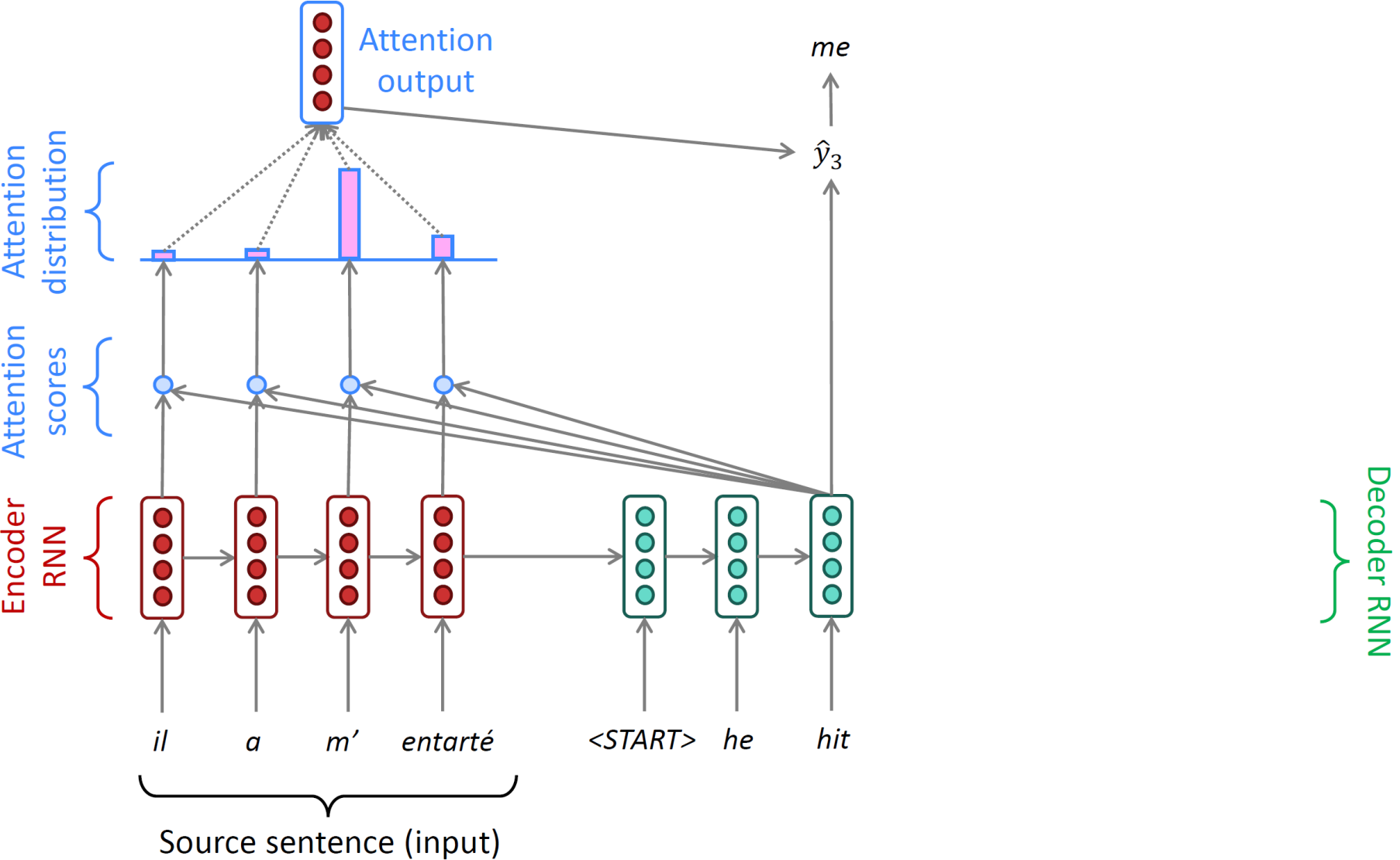

# Seq2Seq with Attention

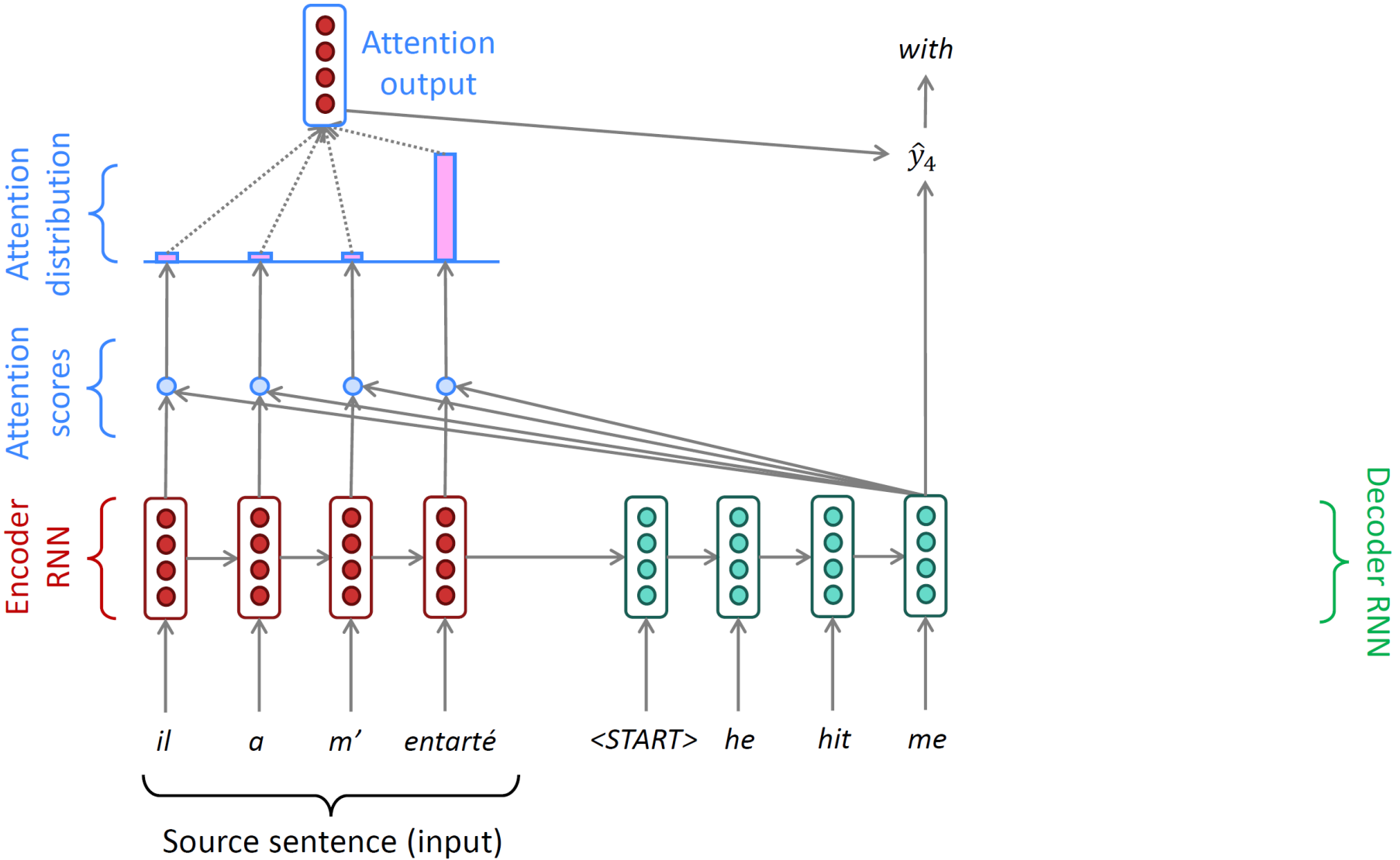

# Seq2Seq with Attention

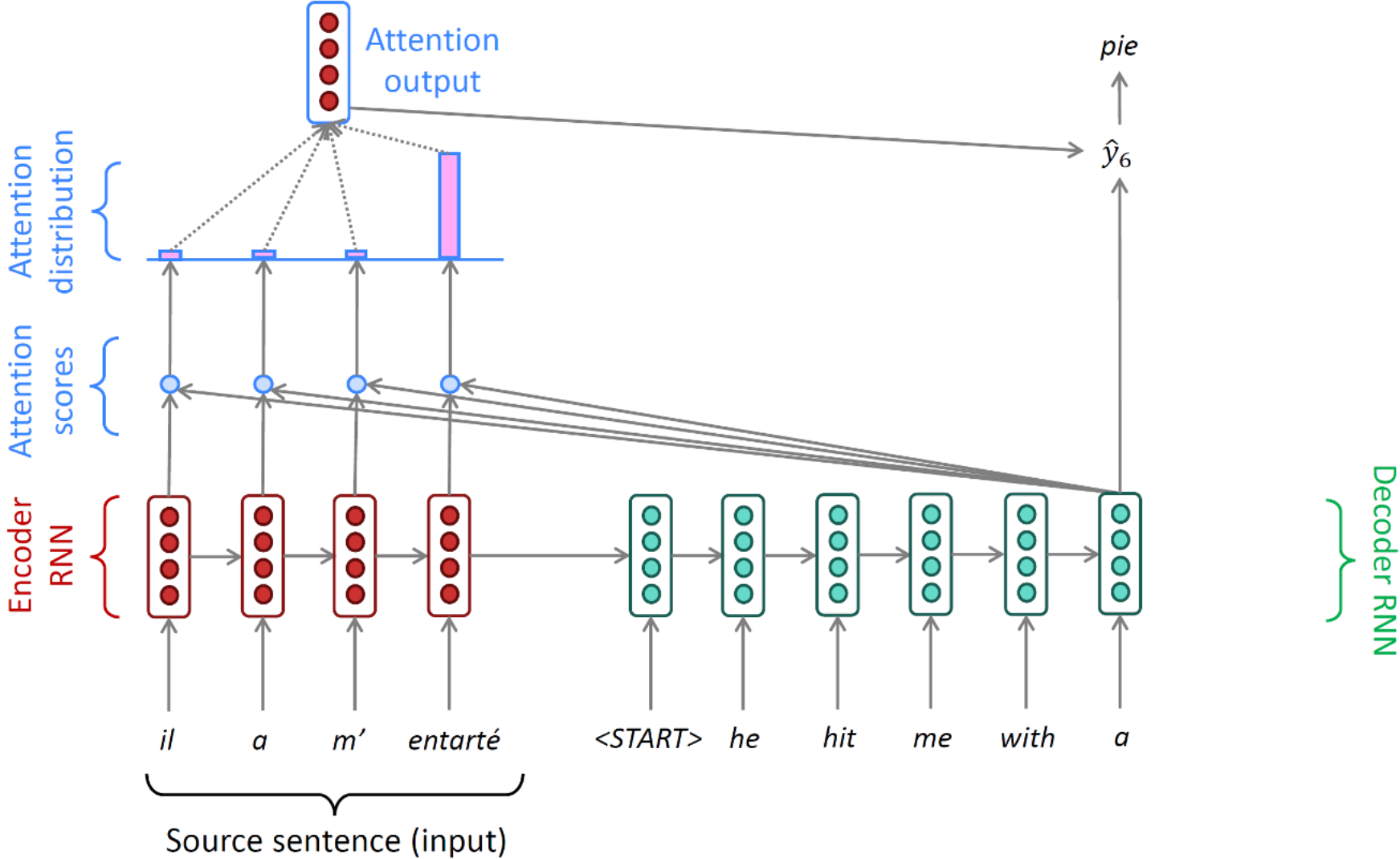

# Seq2Seq with Attention

---

## Summary

- Input sequence  $X$ , encoder  $f_{enc}$ , and decoder  $f_{dec}$
- $f_{enc}(X)$  produces hidden states  $h_1^{enc}, h_2^{enc}, \dots, h_N^{enc}$
- On time step  $t$ , we have decoder hidden state  $h_t$
- Compute attention score  $e_i = h_t^\top h_i^{enc}$
- Compute attention distribution  $\alpha_i = P_{att}(X_i) = \text{softmax}(e_i)$
- Attention output:  $h_{att}^{enc} = \sum_i \alpha_i h_i^{enc}$
- $Y_t \sim g(h_t, h_{att}^{enc}; \theta)$ 
  - Sample an output using both  $h_t$  and  $h_{att}^{enc}$

# Attention

- It significantly improves NMT.
- It solves the bottleneck problem and the long-term dependency issue.
- Also helps gradient vanishing problem.
- Provides some interpretability
  - Understanding which word the RNN encoder focuses on
- Attention is a general technique
  - Given a set of vector values  $V_i$  and vector query  $q$
  - Attention computes a weighted sum of values depending on  $q$

	he	hit	me	with	a	pie
il	black	light	light	light	light	light
a	light	dark	light	light	light	light
m'	light	light	dark	light	light	light
entarté	light	dark	light	black	black	black

## Other use cases:

- Attention can be viewed as a module.
- In encoder and decoder (more on this later)
- A representation of a set of points
  - Pointer network (Vinyals, Forunato, Jaitly '15)
  - Deep Sets (Zaheer et al., '17)
- Convolutional neural networks
  - To include non-local information in CNN (Non-local network, '18)

# Attention

---

- Representation learning:
  - A method to obtain a fixed representation corresponding to a query  $q$  from an arbitrary set of representations  $\{V_i\}$
  - Attention distribution:  $\alpha_i = \text{softmax}(f(v_i, q))$
  - Attention output:  $v_{att} = \sum_i \alpha_i v_i$
- Attent variant:  $f(v_i, q)$ 
  - Multiplicative attention:  $f(v_i, q) = q^\top W h_i$ ,  $W$  is a weight matrix
  - Additive attention:  $f(v_i, q) = u^\top \tanh(W_1 v_i + W_2 q)$

# Key-query-value attention

- Obtain  $q_t, v_t, k_t$  from  $X_t$
- $q_t = W^q X_t; v_t = W^v X_t; k_t = W^k X_t$  (position encoding omitted)
  - $W^q, W^v, W^k$  are learnable weight matrices
- $\alpha_{i,j} = \text{softmax}(q_i^\top k_j); \text{out}_i = \sum_k \alpha_{i,j} v_j$
- Intuition: key, query, and value can focus on different parts of input

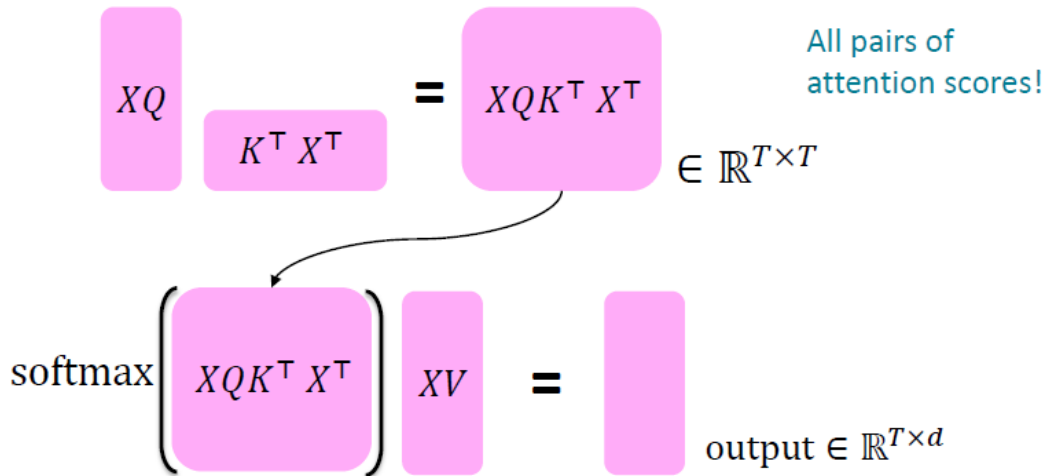

# Attention is all you need (Vaswani '17)

- A pure attention-based architecture for sequence modeling
  - No RNN at all!
- Basic component: self-attention,  $Y = f_{SA}(X; \theta)$ 
  - $X_t$  uses attention on entire  $X$  sequence
  - $Y_t$  computed from  $X_t$  and the attention output
- Computing  $Y_t$ 
  - Key  $k_{t'}$ , value  $v_{t'}$ , query  $q_t$  from  $X_t$ 
    - $(k_t, v_t, q_t) = g_1(X_t; \theta)$
  - Attention distribution  $\alpha_{t,j} = \text{softmax}(q_t^\top k_j)$ 
    - Attention output  $out_t = \sum_j \alpha_{t,j} v_j$
  - $Y_t = g_2(out_t; \theta)$

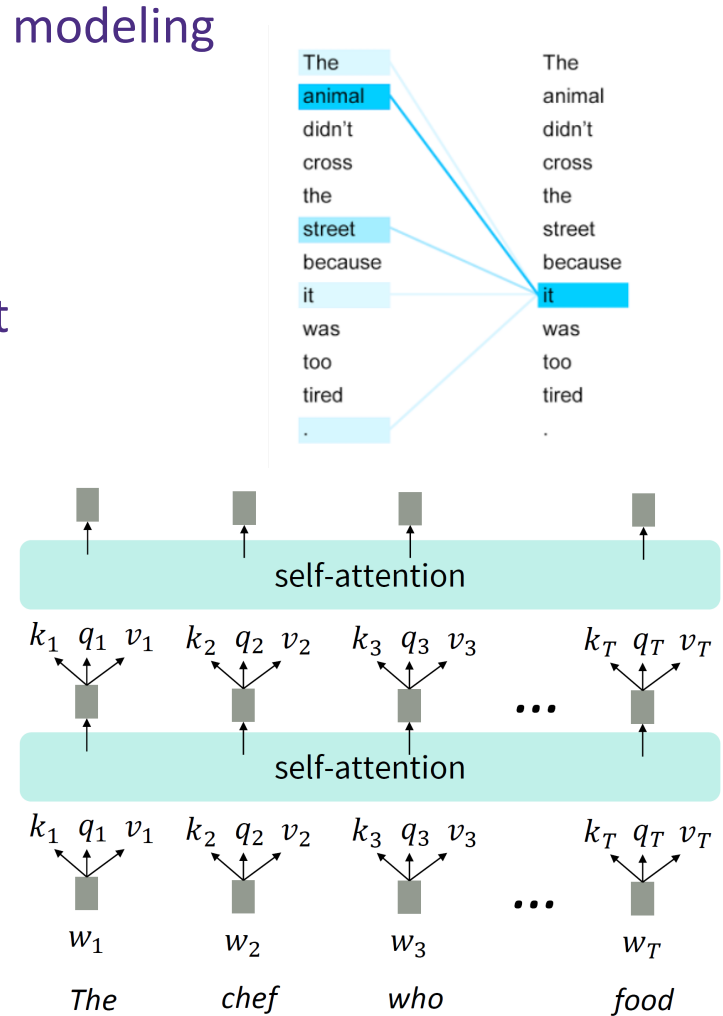

# Issues of Vanilla Self-Attention

---

- Attention is order-invariant
- Lack of non-linearities
  - All the weights are simple weighted average
- Capability of autoregressive modeling
  - In generation tasks, the model cannot “look at the future”
  - e.g. Text generation:
    - $Y_t$  can only depend on  $X_{i < t}$
    - But vanilla self-attention requires the entire sequence

# Position Encoding

- Vanilla self-attention

- $(k_t, v_t, q_t) = g_1(X_t; \theta)$

- $\alpha_{t,j} = \text{softmax}(q_t^\top k_j)$

- Attention output  $out_t = \sum_j \alpha_{t,j} v_j$

- Idea: position encoding:

- $p_i$ : an embedding vector (feature) of position  $i$

- $(k_t, v_t, q_t) = g_1([X_t, p_t]; \theta)$

- In practice: Additive is sufficient:  $k_t \leftarrow \tilde{k}_t + p_t, q_t \leftarrow \tilde{q}_t + p_t, v_t \leftarrow \tilde{v}_t + p_t$ ;

- $(\tilde{k}_t, \tilde{v}_t, \tilde{q}_t) = g_1(X_t; \theta)$

- $p_t$  is only included in the first layer

# Position Encoding

## $p_t$ design 1: Sinusoidal position representation

- Pros:
  - simple
  - naturally models “relative position”
  - Easily applied to long sequences
- Cons:
  - Not learnable
  - Generalization poorly to sequences longer than training data

$$p_i = \begin{pmatrix} \sin(i/10000^{2*1/d}) \\ \cos(i/10000^{2*1/d}) \\ \vdots \\ \sin(i/10000^{2*\frac{d}{2}/d}) \\ \cos(i/10000^{2*\frac{d}{2}/d}) \end{pmatrix}$$

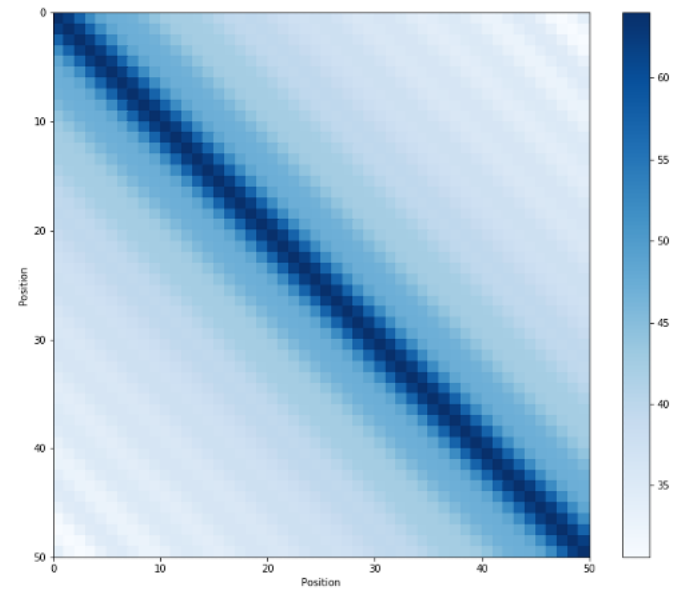

Heatmap of  $p_i^T p_j$

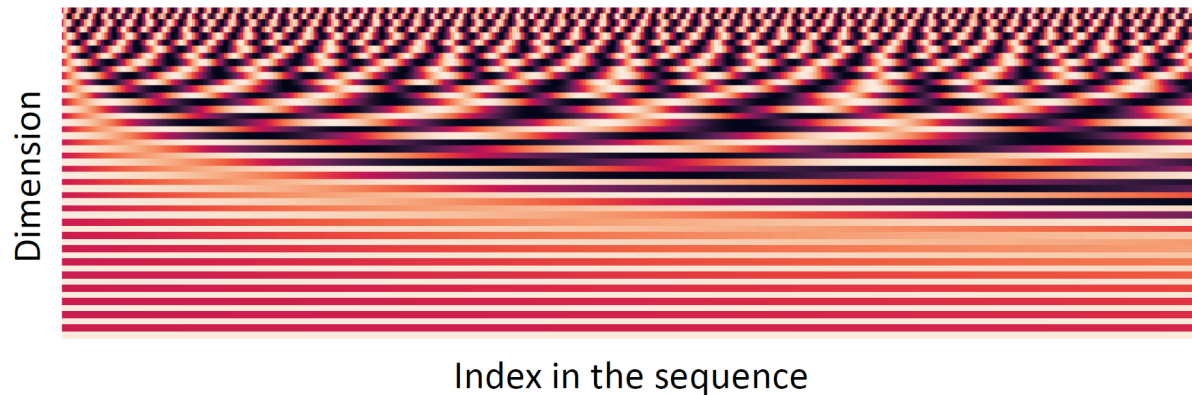

# Position Encoding

---

## $p_t$ design 2: Learned representation

- Assume maximum length  $L$ , learn a matrix  $p \in \mathbb{R}^{d \times T}$ ,  $p_t$  is a column of  $p$
- Pros:
  - Flexible
  - Learnable and more powerful
- Cons:
  - Need to assume a fixed maximum length  $L$
  - Does not work at all for length above  $L$

# Combine Self-Attention with Nonlinearity

- Vanilla self-attention
  - No element-wise activation (e.g., ReLU, tanh)
  - Only weighted average and softmax operator
- Fix:
  - Add an MLP to process  $out_i$
  - $m_i = MLP(out_i) = W_2 \text{ReLU}(W_1 out_i + b_1) + b_2$
  - Usually do not put activation layer before softmax

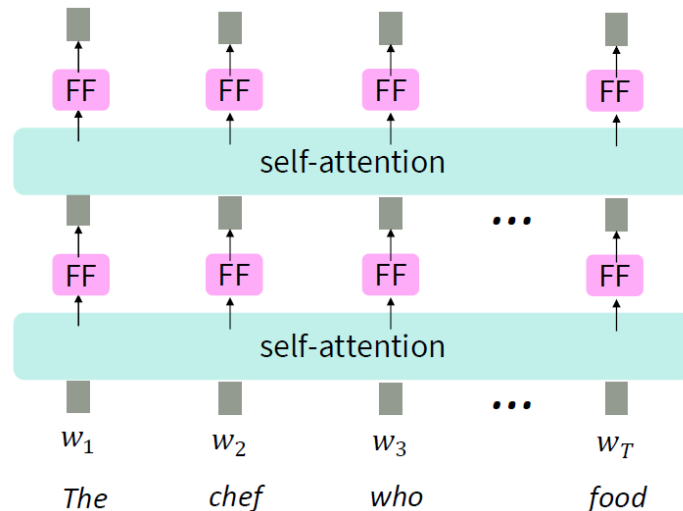

# Masked Attention

- In language model decoder:  $P(Y_t | X_{i < t})$ 
  - $out_t$  cannot look at future  $X_{i > t}$
- Masked attention
  - Compute  $e_{i,j} = q_i^\top k_j$  as usual
  - Mask out  $e_{i>j}$  by setting  $e_{i>j} = -\infty$ 
    - $e \odot (1 - M) \leftarrow -\infty$
    - $M$  is a fixed 0/1 mask matrix
  - Then compute  $\alpha_i = \text{softmax}(e_i)$
  - Remarks:
    - $M = 1$  for full self-attention
    - Set  $M$  for arbitrary dependency ordering

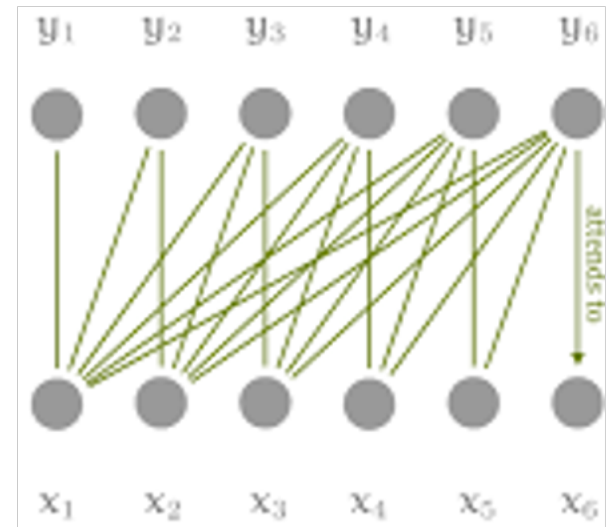
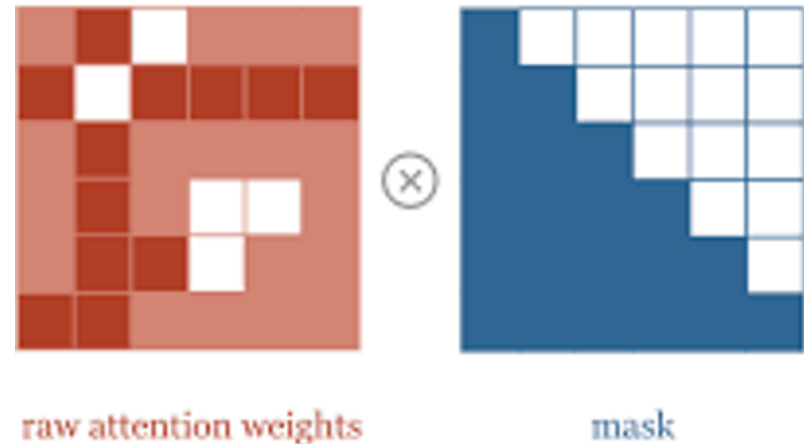

# Transformer

## Transformer-based sequence-to-sequence modeling

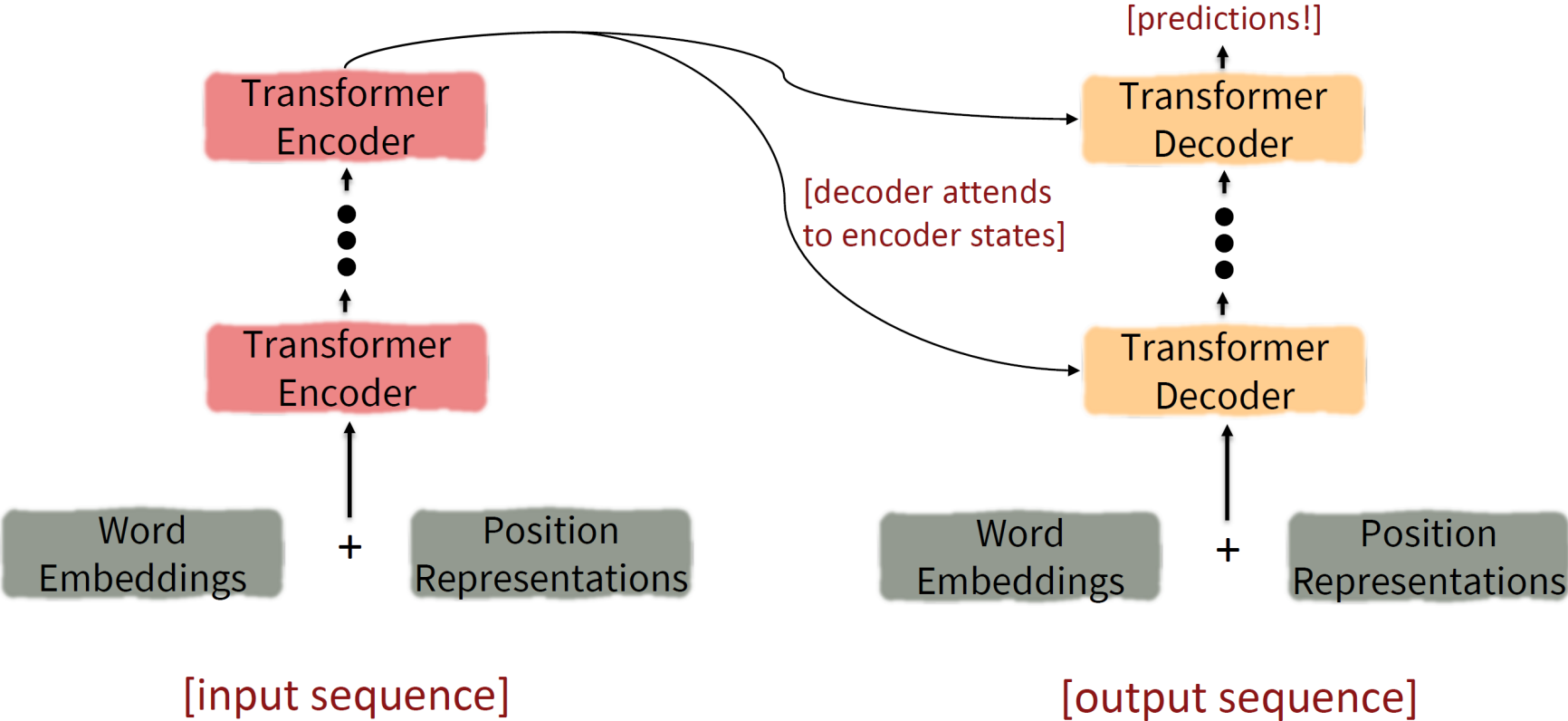

# Key-query-value attention

- Obtain  $q_t, v_t, k_t$  from  $X_t$
- $q_t = W^q X_t; v_t = W^v X_t; k_t = W^k X_t$  (position encoding omitted)
  - $W^q, W^v, W^k$  are learnable weight matrices
- $\alpha_{i,j} = \text{softmax}(q_i^\top k_j); \text{out}_i = \sum_k \alpha_{i,j} v_j$
- Intuition: key, query, and value can focus on different parts of input

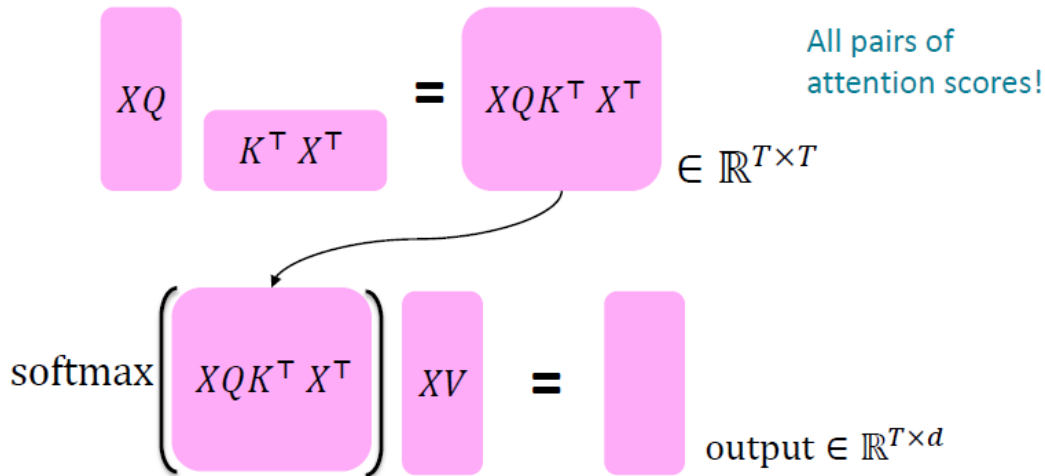

# Multi-headed attention

- Standard attention: single-headed attention
  - $X_t \in \mathbb{R}^d, Q, K, V \in \mathbb{R}^{d \times d}$
  - We only look at a single position  $j$  with high  $\alpha_{i,j}$
  - What if we want to look at different  $j$  for different reasons?
- Idea: define  $h$  separate attention heads
  - $h$  different attention distributions, keys, values, and queries
  - $Q^\ell, K^\ell, V^\ell \in \mathbb{R}^{d \times \frac{d}{h}}$  for  $1 \leq \ell \leq h$
  - $\alpha_{i,j}^\ell = \text{softmax}((q_i^\ell)^\top k_j^\ell); \text{out}_i^\ell = \sum_j \alpha_{i,j}^\ell v_j^\ell$

**#Params Unchanged!**

## Single-head attention

(just the query matrix)

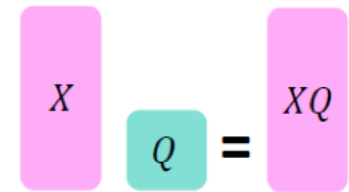

## Multi-head attention

(just two heads here)

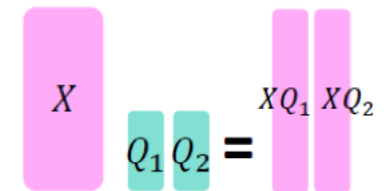

# Multi-headed attention

- Standard attention: single-headed attention
  - $X_t \in \mathbb{R}^d, Q, K, V \in \mathbb{R}^{d \times d}$
  - We only look at a single position  $j$  with high  $\alpha_{i,j}$
  - What if we want to look at different  $j$  for different reasons?
- Idea: define  $h$  separate attention heads
  - $h$  different attention distributions, keys, values, and queries
  - $Q^\ell, K^\ell, V^\ell \in \mathbb{R}^{d \times \frac{d}{h}}$  for  $1 \leq \ell \leq h$
  - $\alpha_{i,j}^\ell = \text{softmax}((q_i^\ell)^\top k_j^\ell); out_i^\ell = \sum_j \alpha_{i,j}^\ell v_j^\ell$

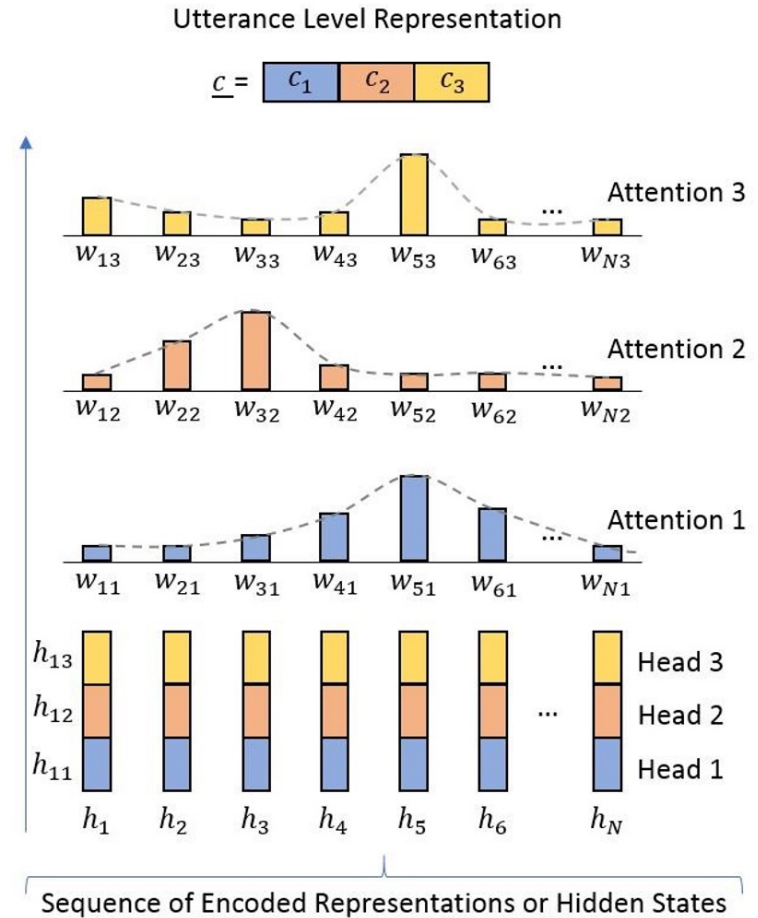

# Transformer

## Transformer-based sequence-to-sequence model

- Basic building blocks: self-attention
  - Position encoding
  - Post-processing MLP
  - Attention mask
- Enhancements:
  - Key-query-value attention
  - Multi-headed attention
  - Architecture modifications:
    - Residual connection
    - Layer normalization

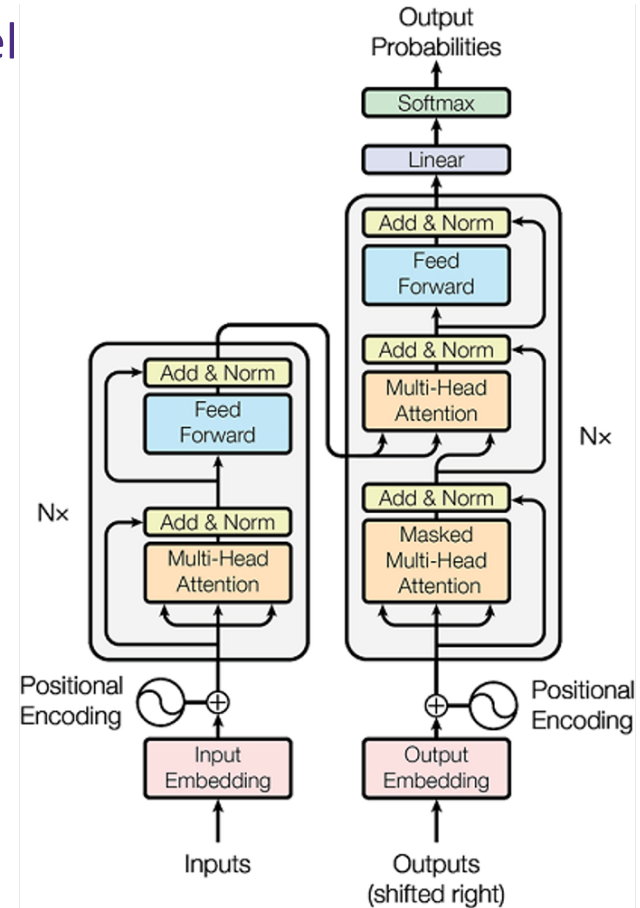

# Transformer

## Machine translation with transformer

Model	BLEU		Training Cost (FLOPs)	
	EN-DE	EN-FR	EN-DE	EN-FR
ByteNet [18]	23.75			
Deep-Att + PosUnk [39]		39.2		$1.0 \cdot 10^{20}$
GNMT + RL [38]	24.6	39.92	$2.3 \cdot 10^{19}$	$1.4 \cdot 10^{20}$
ConvS2S [9]	25.16	40.46	$9.6 \cdot 10^{18}$	$1.5 \cdot 10^{20}$
MoE [32]	26.03	40.56	$2.0 \cdot 10^{19}$	$1.2 \cdot 10^{20}$
Deep-Att + PosUnk Ensemble [39]		40.4		$8.0 \cdot 10^{20}$
GNMT + RL Ensemble [38]	26.30	41.16	$1.8 \cdot 10^{20}$	$1.1 \cdot 10^{21}$
ConvS2S Ensemble [9]	26.36	<b>41.29</b>	$7.7 \cdot 10^{19}$	$1.2 \cdot 10^{21}$
Transformer (base model)	27.3	38.1	<b><math>3.3 \cdot 10^{18}</math></b>	
Transformer (big)	<b>28.4</b>	<b>41.8</b>	$2.3 \cdot 10^{19}$	

# Transformer

---

- Limitations of transformer: Quadratic computation cost
  - Linear for RNNs
  - Large cost for large sequence length, e.g.,  $L > 10^4$
  
- Follow-ups:
  - Large-scale training: transformer-XL; XL-net ('20)
  - Projection tricks to  $O(L)$ : Linformer ('20)
  - Math tricks to  $O(L)$ : Performer ('20)
  - Sparse interactions: Big Bird ('20)
  - Deeper transformers: DeepNet ('22)

# Transformer for Images

- Vision Transformer ('21)
  - Decompose an image to 16x16 patches and then apply transformer encoder

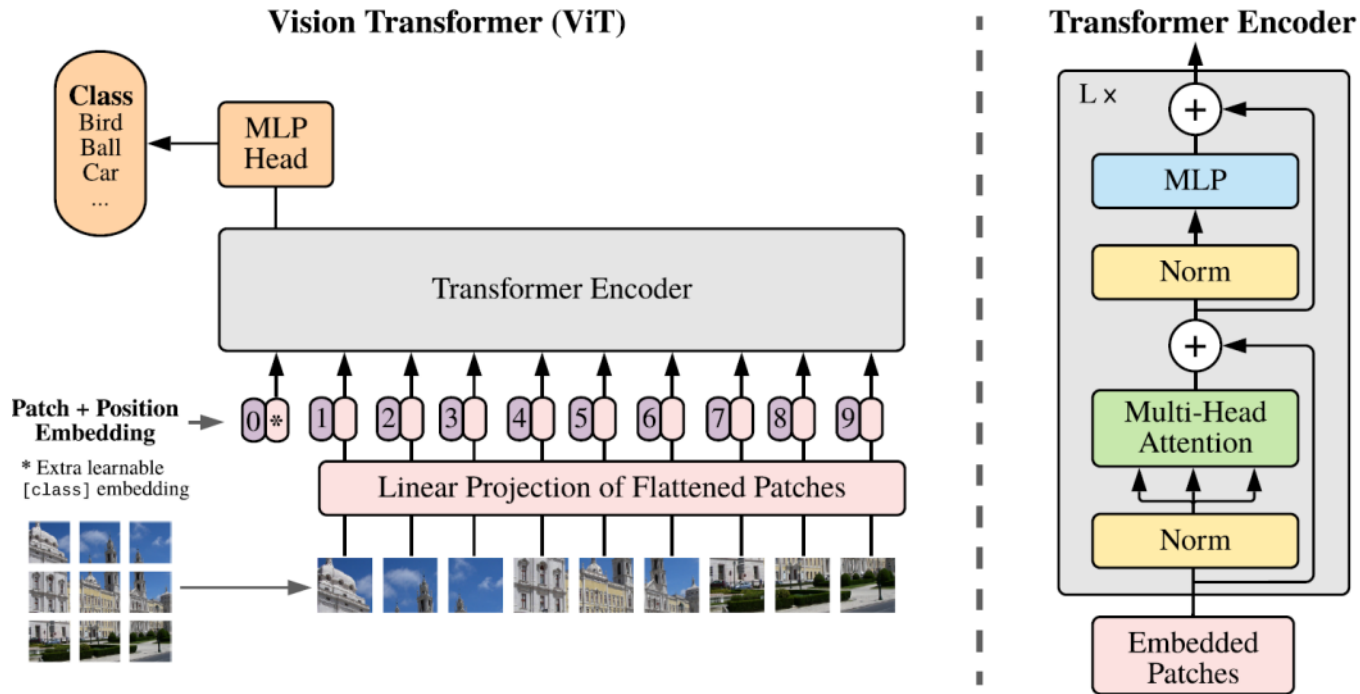

# Transformer for Images

- Swin Transformer ('21)
  - Build hierarchical feature maps at different resolution
    - Self-attention only within each block
    - Shifted block partitions to encode information between blocks

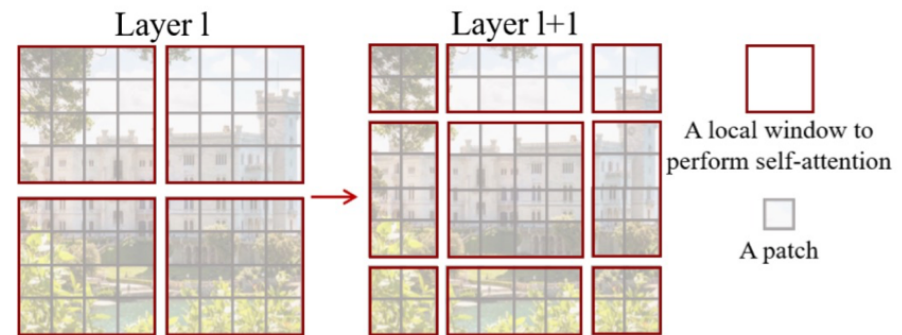
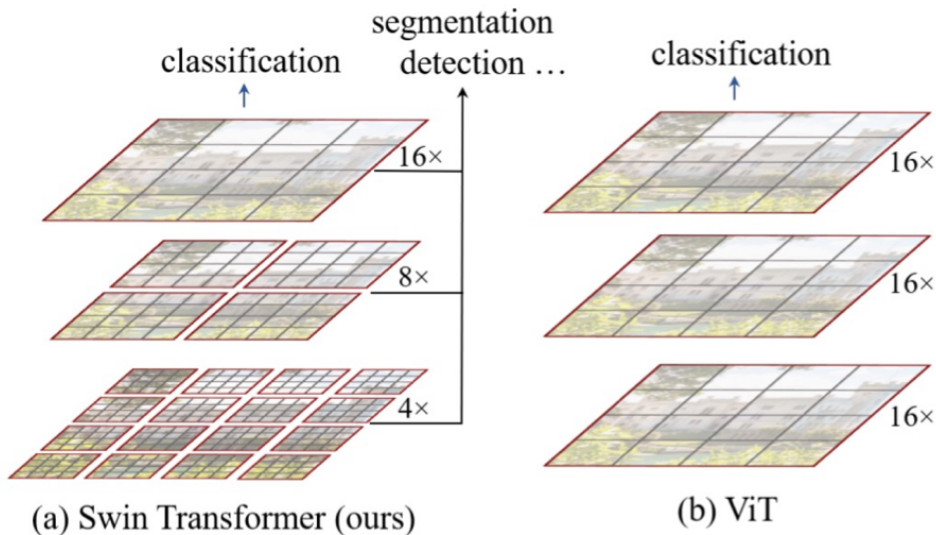
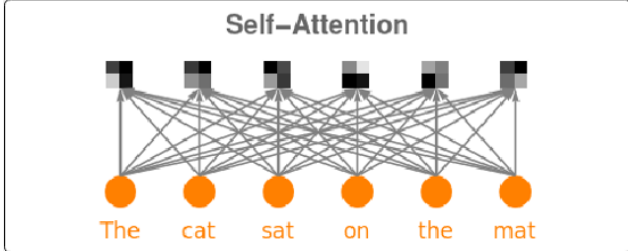
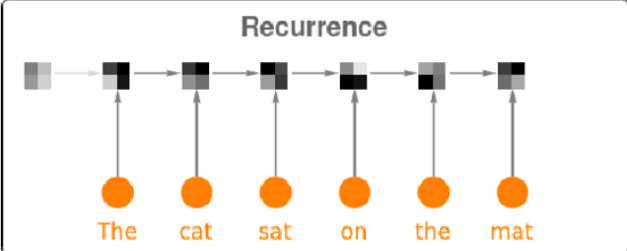
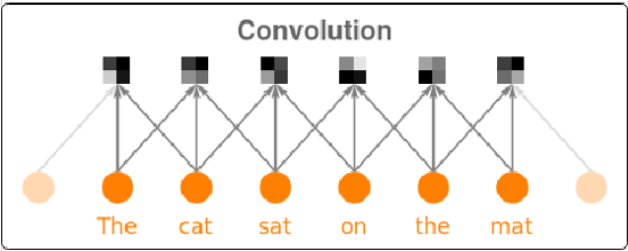

Figure 2. An illustration of the *shifted window* approach for com-

# CNN vs. RNN vs. Attention



# Summary

---

- Language model & sequence to sequence model:
  - Fundamental ideas and methods for sequence modeling
- Attention mechanism
  - So far the most successful idea for sequence data in deep learning
  - A scale/order-invariant representation
  - Transformer: a fully attention-based architecture for sequence data
  - Transformer + Pretraining: the core idea in today's NLP tasks
- LSTM is still useful in lightweight scenarios

# Other architectures

---

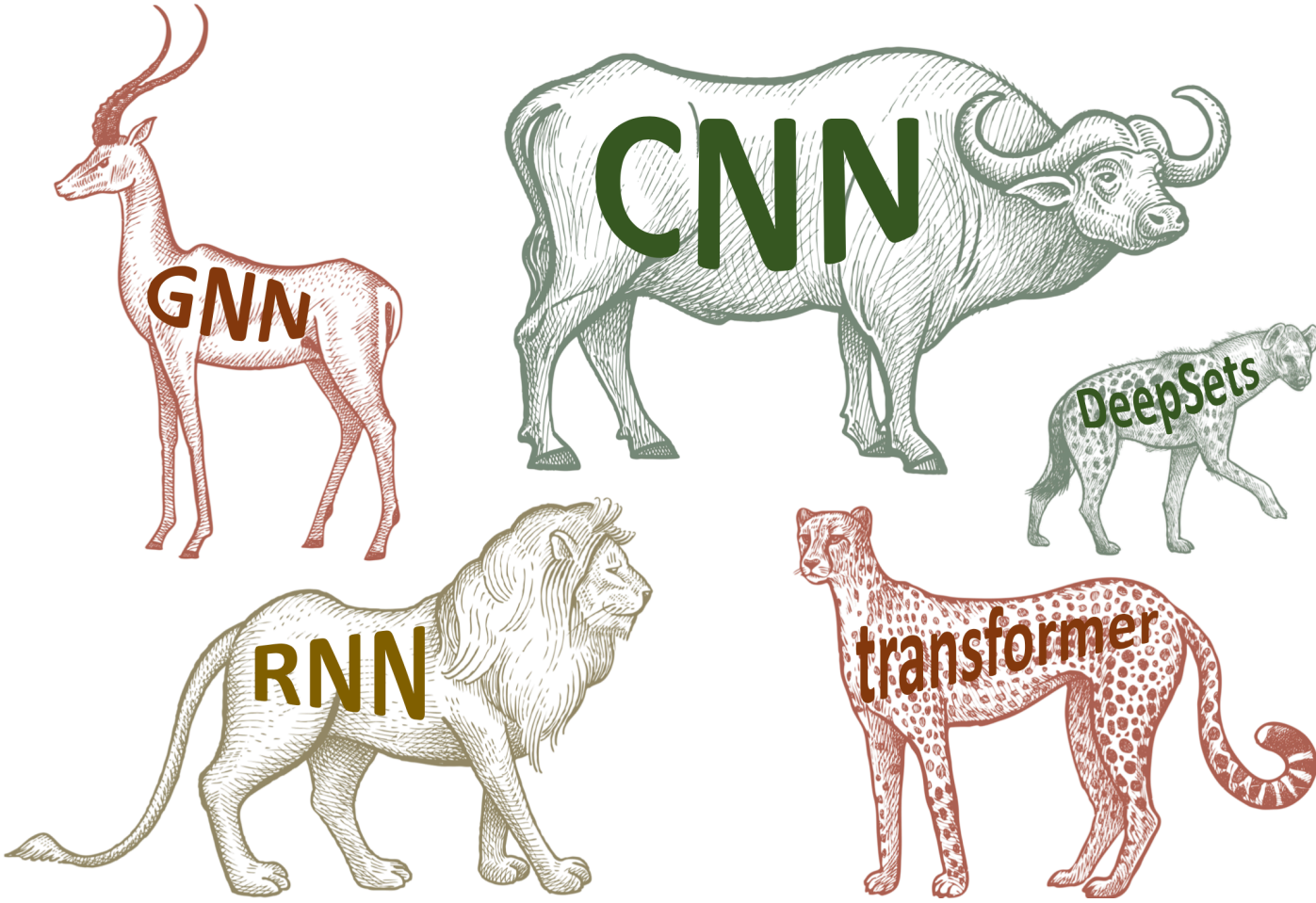

# Graph Neural Networks

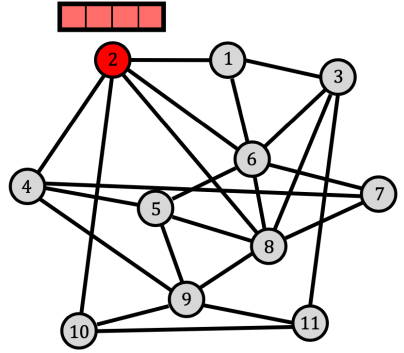
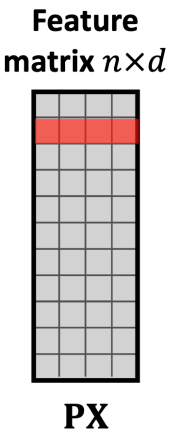
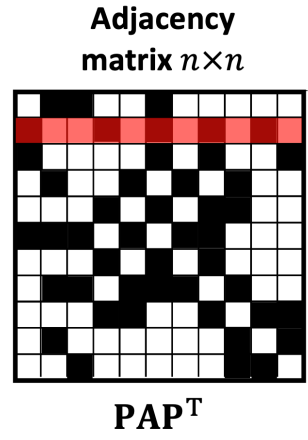
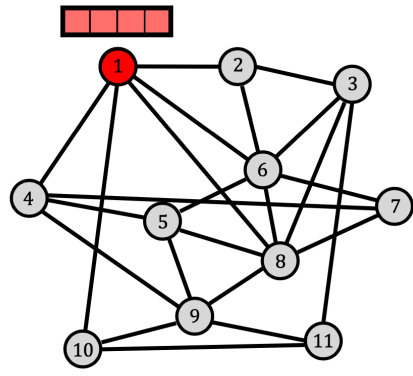
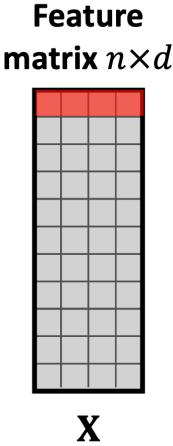
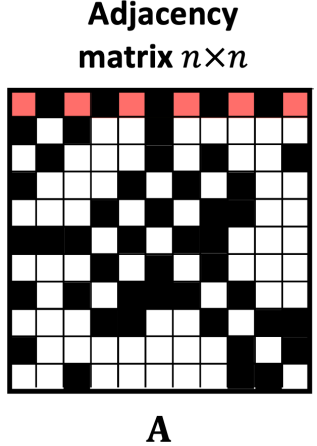

arbitrary ordering of nodes

# Graph Neural Networks

permutation-equivariant

$$\mathbf{F}(\mathbf{P}\mathbf{X}, \mathbf{P}\mathbf{A}\mathbf{P}^T) = \mathbf{P}\mathbf{F}(\mathbf{X}, \mathbf{A})$$

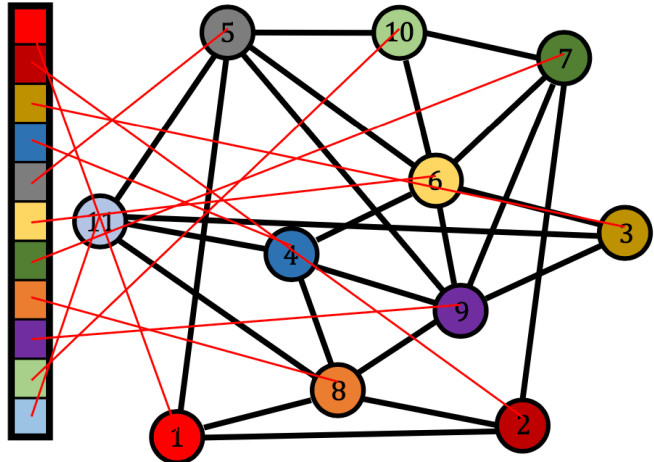

# Geometric Deep Learning

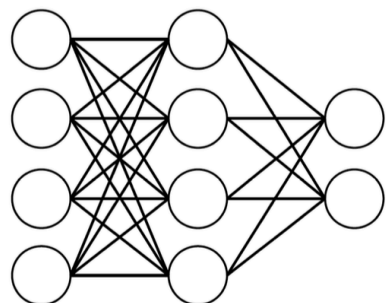

**Perceptrons**  
Function regularity

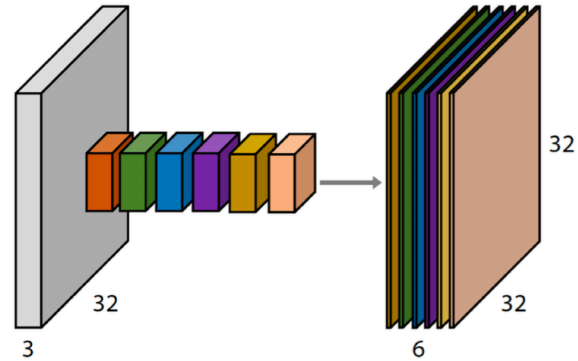

**CNNs**  
Translation

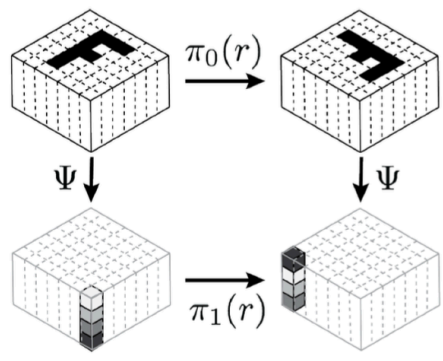

**Group-CNNs**  
Translation+Rotation



**DeepSets / Transformers**  
Permutation

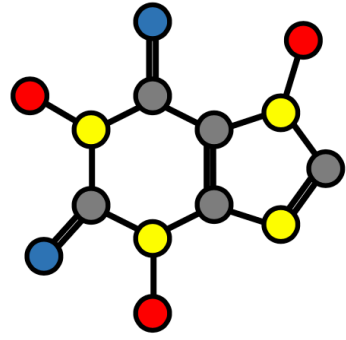

**GNNs**  
Permutation



**Intrinsic CNNs**  
Local frame choice