

# Database System Internals

## Concurrency Control Intro

Paul G. Allen School of Computer Science and Engineering  
University of Washington, Seattle

# About Lab 3

- In lab 3, we implement transactions
- Focus on concurrency control
  - Want to run many transactions at the same time
  - Transactions want to read and write same pages
  - Will use locks to ensure conflict serializable execution
  - Use strict 2PL
- Build your own lock manager
  - Understand how locking works in depth
  - Ensure transactions rather than threads hold locks
    - Many threads can execute different pieces of the same transaction
    - Need to detect deadlocks and resolve them by aborting a transaction
  - But use Java synchronization to protect your data structures

# Motivating Example

Client 1:  
`UPDATE Budget`  
`SET money=money-100`  
`WHERE pid = 1`

`UPDATE Budget`  
`SET money=money+60`  
`WHERE pid = 2`

`UPDATE Budget`  
`SET money=money+40`  
`WHERE pid = 3`

Client 2:  
`SELECT sum(money)`  
`FROM Budget`

Would like to treat  
each group of  
instructions as a unit

# Transaction

**Definition:** a transaction is a sequence of updates to the database with the property that either all complete, or none completes (all-or-nothing).

```
START TRANSACTION
```

```
[SQL statements]
```

```
COMMIT or ROLLBACK (=ABORT)
```

May be omitted if  
autocommit is off:  
first SQL query  
starts txn

In ad-hoc SQL: each statement = one transaction  
This is referred to as autocommit

# Motivating Example

```
START TRANSACTION
```

```
UPDATE Budget
```

```
SET money=money-100
```

```
WHERE pid = 1
```

```
UPDATE Budget
```

```
SET money=money+60
```

```
WHERE pid = 2
```

```
UPDATE Budget
```

```
SET money=money+40
```

```
WHERE pid = 3
```

```
COMMIT (or ROLLBACK)
```

```
SELECT sum(money)  
FROM Budget
```

With autocommit and without **START TRANSACTION**, each SQL command is a transaction

# ROLLBACK

- If the app gets to a place where it can't complete the transaction successfully, it can execute **ROLLBACK**
- This causes the system to “abort” the transaction
  - Database returns to a state without any of the changes made by the transaction
- Several reasons: user, application, system

# Transactions

- Major component of database systems
- Critical for most applications; arguably more so than SQL
- Turing awards to database researchers:
  - Charles Bachman 1973
  - Edgar Codd 1981 for inventing relational dbs
  - **Jim Gray 1998 for inventing transactions**
  - Mike Stonebraker 2015 for INGRES and Postgres
    - And many other ideas after that

# ACID Properties

# ACID Properties

- **Atomicity:** Either all changes performed by transaction occur or none occurs
- **Consistency:** A transaction as a whole does not violate integrity constraints
- **Isolation:** Transactions appear to execute one after the other in sequence
- **Durability:** If a transaction commits, its changes will survive failures

# What Could Go Wrong?

Why is it hard to provide ACID properties?

- **Concurrent** operations
  - Isolation problems
  - We saw one example earlier
- **Failures** can occur at any time
  - Atomicity and durability problems
  - Later lectures
- Transaction may need to **abort**

# Terminology Needed For Lab 3

- **STEAL or NO-STEAL**

- Can an update made by an uncommitted transaction overwrite the most recent committed value of a data item on disk?

- **FORCE or NO-FORCE**

- Should all updates of a transaction be forced to disk before the transaction commits?

- Easiest for recovery: NO-STEAL/FORCE (lab 3)
- Highest performance: STEAL/NO-FORCE (lab 4)
- We will get back to this next week

# Concurrent Execution Problems

- **Write-read conflict: dirty read, inconsistent read**
  - A transaction reads a value written by another transaction that has not yet committed
- **Read-write conflict: unrepeatable read**
  - A transaction reads the value of the same object twice. Another transaction modifies that value in between the two reads
- **Write-write conflict: lost update**
  - Two transactions update the value of the same object. The second one to write the value overwrites the first change

# Schedules

A *schedule* is a sequence of interleaved actions from all transactions

# Example

A and B are elements  
in the database  
t and s are variables  
in tx source code

T1	T2
READ(A, t)	READ(A, s)
t := t+100	s := s*2
WRITE(A, t)	WRITE(A,s)
READ(B, t)	READ(B,s)
t := t+100	s := s*2
WRITE(B,t)	WRITE(B,s)

# A Serial Schedule

T1

T2

---

READ(A, t)  
t := t+100  
WRITE(A, t)  
READ(B, t)  
t := t+100  
WRITE(B,t)

READ(A,s)  
s := s\*2  
WRITE(A,s)  
READ(B,s)  
s := s\*2  
WRITE(B,s)

A = 2  
B = 2

A = 102  
B = 102

A = 204  
B = 204

# A Serial Schedule

T1

T2

A = 2  
B = 2

---

READ(A,s)  
s := s\*2  
WRITE(A,s)  
READ(B,s)  
s := s\*2  
WRITE(B,s)

A = 4  
B = 4

READ(A, t)  
t := t+100  
WRITE(A, t)  
READ(B, t)  
t := t+100  
WRITE(B,t)

A = 104  
B = 104

# Serializable Schedule

A schedule is serializable if it is equivalent to a serial schedule

# A Serializable Schedule

T1	T2	
		A = 2 B = 2
READ(A, t) t := t+100 WRITE(A, t)		A = 102 B = 2
	READ(A,s) s := s*2 WRITE(A,s)	A = 204 B = 2
READ(B, t) t := t+100 WRITE(B,t)		A = 204 B = 102
	READ(B,s) s := s*2 WRITE(B,s)	A = 204 B = 204

This is a **serializable** schedule.  
This is NOT a serial schedule

# A Non-Serializable Schedule

T1	T2	
		A = 2 B = 2
READ(A, t)		A = 102 B = 2
t := t+100		
WRITE(A, t)		
	READ(A,s)	A = 204 B = 2
	s := s*2	
	WRITE(A,s)	
	READ(B,s)	A = 204 B = 4
	s := s*2	
	WRITE(B,s)	
READ(B, t)		A = 204 B = 104
t := t+100		
WRITE(B,t)		

# Serializable Schedules

- The role of the scheduler is to ensure that the schedule is serializable

**Q:** Why not run only serial schedules ?  
I.e. run one transaction after the other ?

# Serializable Schedules

- The role of the scheduler is to ensure that the schedule is serializable

**Q:** Why not run only serial schedules ?  
I.e. run one transaction after the other ?

**A:** Because of very poor throughput due to disk latency.

**Lesson:** main memory databases may schedule TXNs serially

# Still Serializable, but...

T1  
READ(A, t)  
t := t+100  
WRITE(A, t)

Schedule is serializable  
because  $t=t+100$  and  
 $s=s+200$  commute

READ(B, t)  
t := t+100  
WRITE(B,t)

T2  
READ(A,s)  
s := s + 200  
WRITE(A,s)  
READ(B,s)  
s := s + 200  
WRITE(B,s)

...we don't expect the scheduler to schedule this

# To Be Practical

- Assume worst case updates:
  - Assume cannot commute actions done by transactions
- Therefore, we only care about reads and writes
  - Transaction = sequence of R(A)'s and W(A)'s

$$\begin{array}{l} T_1: r_1(A); w_1(A); r_1(B); w_1(B) \\ T_2: r_2(A); w_2(A); r_2(B); w_2(B) \end{array}$$

# Conflicts

- Write-Read – WR
- Read-Write – RW
- Write-Write – WW

# Conflict Serializability

## Conflicts:

Two actions by same transaction  $T_i$ :

$r_i(X); w_i(Y)$

Two writes by  $T_i, T_j$  to same element

$w_i(X); w_j(X)$

Read/write by  $T_i, T_j$  to same element

$w_i(X); r_j(X)$

$r_i(X); w_j(X)$

# Conflict Serializability

**Definition** A schedule is *conflict serializable* if it can be transformed into a serial schedule by a series of swappings of adjacent non-conflicting actions

- Every **conflict-serializable** schedule is **serializable**
- The converse is not true in general

# Conflict Serializability

Example:

$r_1(A); w_1(A); r_2(A); w_2(A); r_1(B); w_1(B); r_2(B); w_2(B)$

# Conflict Serializability

Example:

$r_1(A); w_1(A); r_2(A); w_2(A); r_1(B); w_1(B); r_2(B); w_2(B)$



$r_1(A); w_1(A); r_1(B); w_1(B); r_2(A); w_2(A); r_2(B); w_2(B)$

# Conflict Serializability

Example:

$r_1(A); w_1(A); r_2(A); w_2(A); r_1(B); w_1(B); r_2(B); w_2(B)$

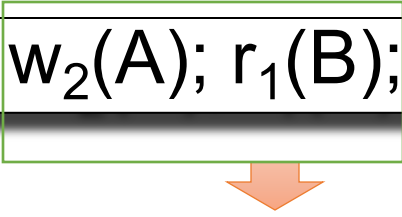

$r_1(A); w_1(A); r_1(B); w_1(B); r_2(A); w_2(A); r_2(B); w_2(B)$

# Conflict Serializability

Example:

$r_1(A); w_1(A); r_2(A); w_2(A); r_1(B); w_1(B); r_2(B); w_2(B)$



$r_1(A); w_1(A); r_2(A); r_1(B); w_2(A); w_1(B); r_2(B); w_2(B)$



$r_1(A); w_1(A); r_1(B); w_1(B); r_2(A); w_2(A); r_2(B); w_2(B)$

# Conflict Serializability

Example:

$r_1(A); w_1(A); r_2(A); w_2(A); r_1(B); w_1(B); r_2(B); w_2(B)$



$r_1(A); w_1(A); r_2(A); r_1(B); w_2(A); w_1(B); r_2(B); w_2(B)$



$r_1(A); w_1(A); r_1(B); w_1(B); r_2(A); w_2(A); r_2(B); w_2(B)$

# Conflict Serializability

Example:

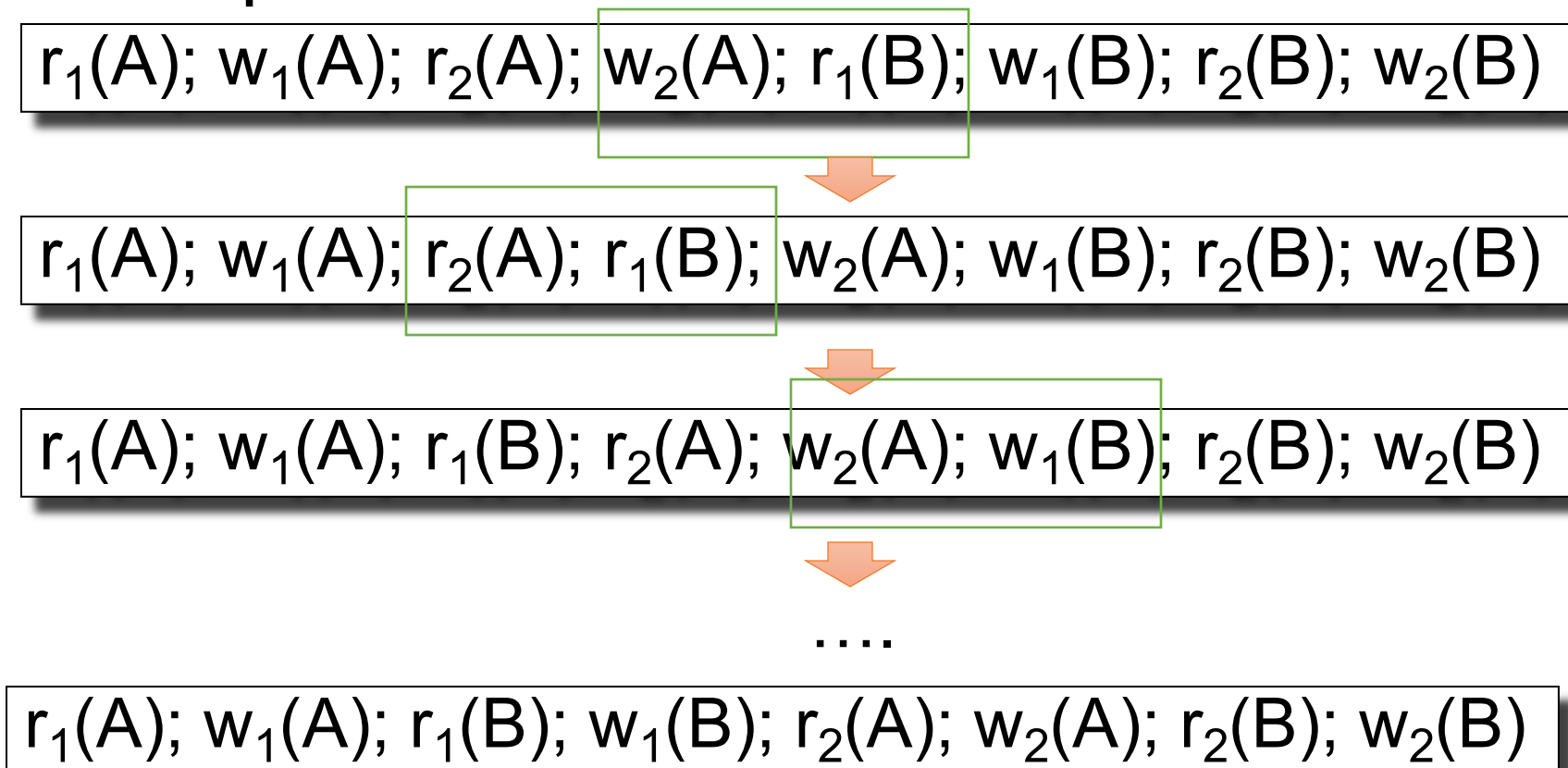

# Testing for Conflict-Serializability

## Precedence graph:

- A node for each transaction  $T_i$ ,
  - An edge from  $T_i$  to  $T_j$  whenever an action in  $T_i$  conflicts with, and comes before an action in  $T_j$
  - No edge for actions in the same transaction
- 
- **The schedule is serializable iff the precedence graph is acyclic**

# Testing for Conflict-Serializability

Important:

Always draw the full graph, unless ONLY asked if (yes or no) the schedule is conflict serializable

# Example 1

$r_2(A); r_1(B); w_2(A); r_3(A); w_1(B); w_3(A); r_2(B); w_2(B)$

①

②

③

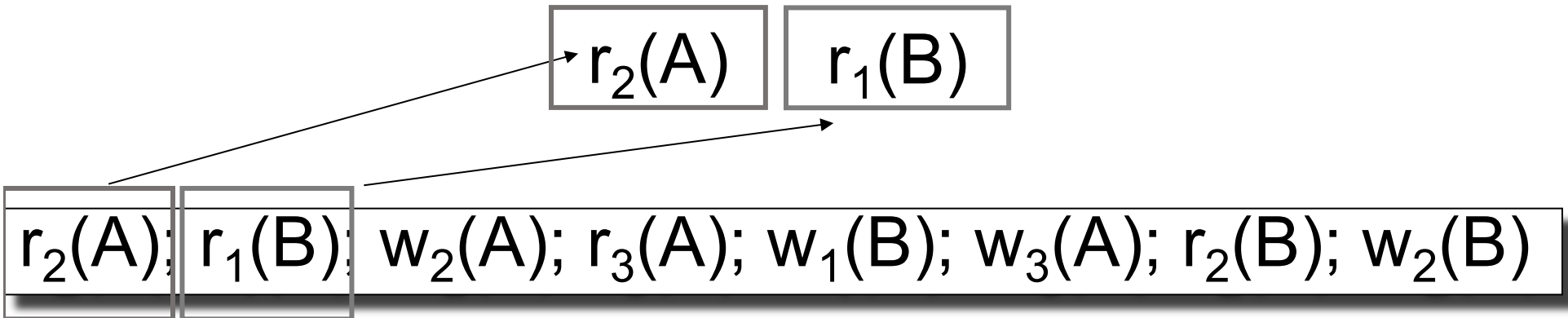

$r_2(A)$

$r_1(B)$

$r_2(A); r_1(B); w_2(A); r_3(A); w_1(B); w_3(A); r_2(B); w_2(B)$

①

②

③

$r_2(A)$

$r_1(B)$

No edge because  
no conflict ( $A \neq B$ )

$r_2(A); r_1(B); w_2(A); r_3(A); w_1(B); w_3(A); r_2(B); w_2(B)$

①

②

③

$r_2(A)$

$w_2(A)$

$r_2(A); r_1(B); w_2(A); r_3(A); w_1(B); w_3(A); r_2(B); w_2(B)$

①

②

③

$r_2(A)$

$w_2(A)$

No edge because  
same txn (2)

$r_2(A); r_1(B); w_2(A); r_3(A); w_1(B); w_3(A); r_2(B); w_2(B)$

①

②

③

$r_2(A)$

$r_3(A)$

?

$r_2(A); r_1(B); w_2(A); r_3(A); w_1(B); w_3(A); r_2(B); w_2(B)$

①

②

③

$r_2(A)$

$w_1(B)$

?

$r_2(A); r_1(B); w_2(A); r_3(A); w_1(B); w_3(A); r_2(B); w_2(B)$

①

②

③

$r_2(A)$

$w_3(A)$

?

$r_2(A); r_1(B); w_2(A); r_3(A); w_1(B); w_3(A); r_2(B); w_2(B)$

①

②

③

$r_2(A)$

$w_3(A)$

Edge! Conflict from  
T2 to T3

$r_2(A); r_1(B); w_2(A); r_3(A); w_1(B); w_3(A); r_2(B); w_2(B)$

①

②

③

$r_2(A)$     $w_3(A)$

Edge! Conflict from T2 to T3

$r_2(A); r_1(B); w_2(A); r_3(A); w_1(B); w_3(A); r_2(B); w_2(B)$

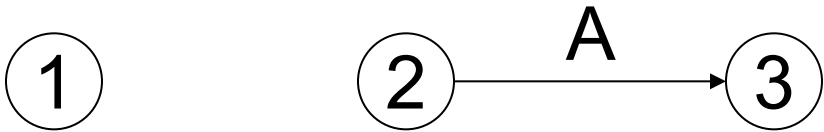

$r_2(A)$

$r_2(B)$

?

$r_2(A); r_1(B); w_2(A); r_3(A); w_1(B); w_3(A); r_2(B); w_2(B)$

And so on until compared every pair of actions...

①

②



③

# Example 1

$r_2(A); r_1(B); w_2(A); r_3(A); w_1(B); w_3(A); r_2(B); w_2(B)$

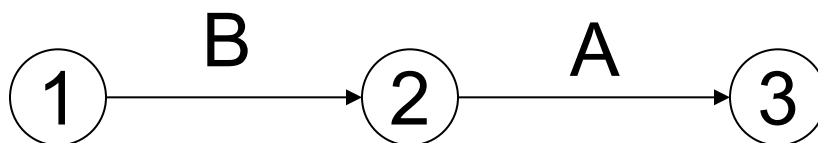

More edges, but repeats of the same directed edge not necessary

# Example 1

$r_2(A); r_1(B); w_2(A); r_3(A); w_1(B); w_3(A); r_2(B); w_2(B)$

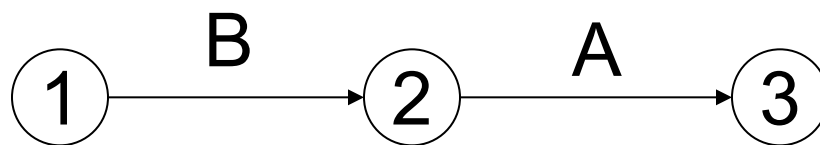

This schedule is **conflict-serializable**

# Example 2

$r_2(A); r_1(B); w_2(A); r_2(B); r_3(A); w_1(B); w_3(A); w_2(B)$

①

②

③

# Example 2

$r_2(A); r_1(B); w_2(A); r_2(B); r_3(A); w_1(B); w_3(A); w_2(B)$

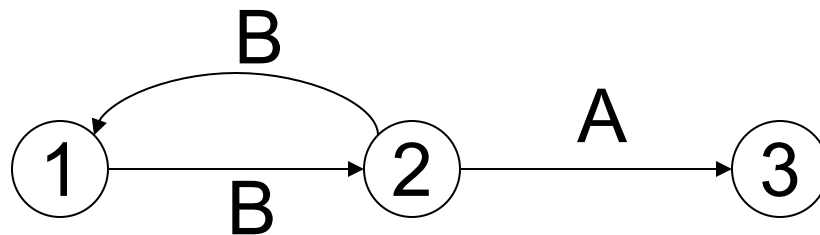

# Example 2

$r_2(A); r_1(B); w_2(A); r_2(B); r_3(A); w_1(B); w_3(A); w_2(B)$

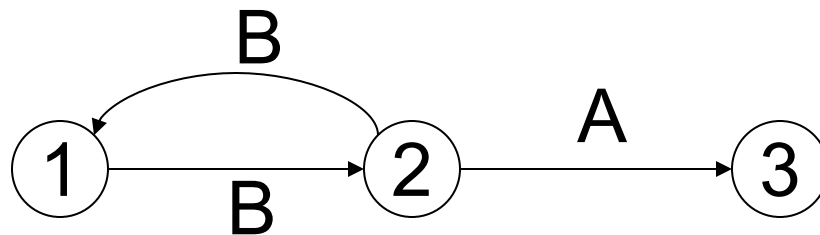

This schedule is **NOT** conflict-serializable

# View Equivalence

- A serializable schedule need not be conflict serializable, even under the “worst case update” assumption

$w_1(X); w_2(X); w_2(Y); w_1(Y); w_3(Y);$

Is this schedule conflict-serializable ?

# View Equivalence

- A serializable schedule need not be conflict serializable, even under the “worst case update” assumption

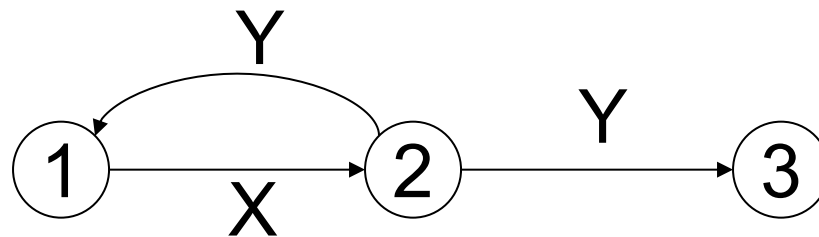

$w_1(X); w_2(X); w_2(Y); w_1(Y); w_3(Y);$

Is this schedule conflict-serializable ?

No...

# View Equivalence

- A serializable schedule need not be conflict serializable, even under the “worst case update” assumption

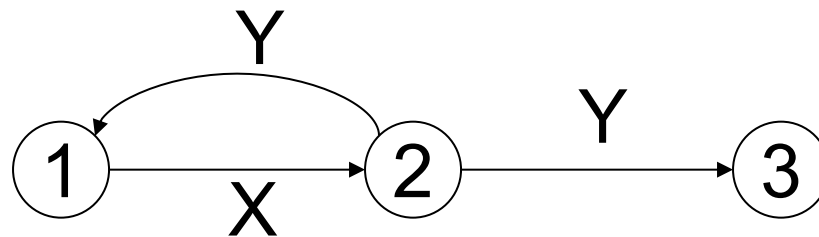

$w_1(X); w_2(X); w_2(Y); w_1(Y); w_3(Y);$

Lost write

$w_1(X); w_1(Y); w_2(X); w_2(Y); w_3(Y);$

Equivalent, but not conflict-equivalent

# View Equivalence

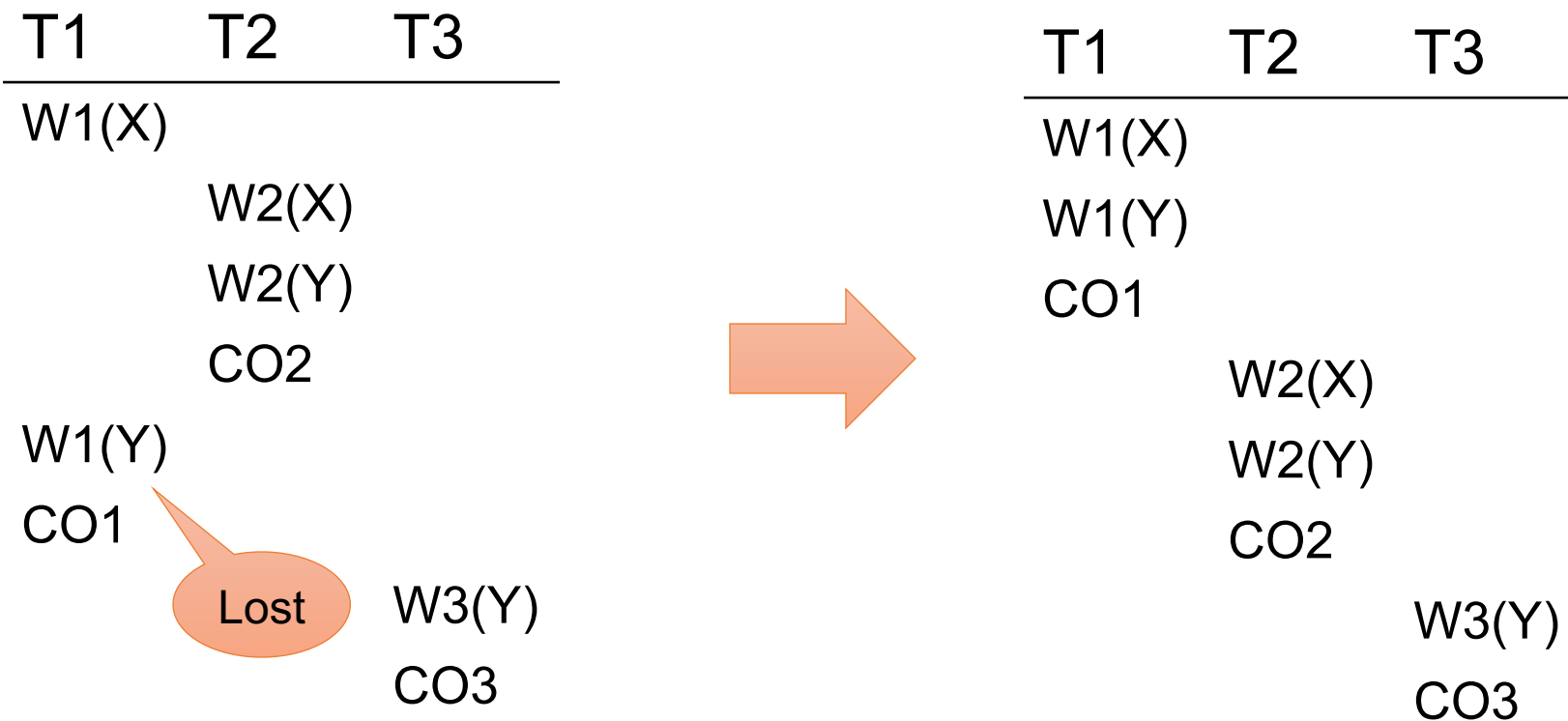

Serializable, but not conflict serializable

# View-Serializability

A schedule is *view serializable* if it is view equivalent to a serial schedule

Remark:

- If a schedule is *conflict serializable*, then it is also *view serializable*
- But not vice versa

# Schedules with Aborted Transactions

- When a transaction aborts, the recovery manager undoes its updates
- But some of its updates may have affected other transactions !

# Schedules with Aborted Transactions

T1	T2
R(A)	
W(A)	
	R(A)
	W(A)
	R(B)
	W(B)
	Commit
Abort	

What's wrong?

# Schedules with Aborted Transactions

T1	T2
R(A)	
W(A)	
	R(A)
	W(A)
	R(B)
	W(B)
	Commit
Abort	

What's wrong?

Cannot abort T1 because cannot undo T2

# Recoverable Schedules

A schedule is *recoverable* if:

- It is conflict-serializable, and
- Whenever a transaction T commits, all transactions that have written elements read by T have already committed

# Recoverable Schedules

A schedule is *recoverable* if:

- It is conflict-serializable, and
- Whenever a transaction T commits, all transactions that **have written elements** read by T have **already committed**

# Recoverable Schedules

T1	T2
R(A)	
W(A)	
	R(A)
	W(A)
	R(B)
	W(B)
	Commit
?	

T1	T2
R(A)	
W(A)	
	R(A)
	W(A)
	R(B)
	W(B)
Commit	
	Commit

# Recoverable Schedules

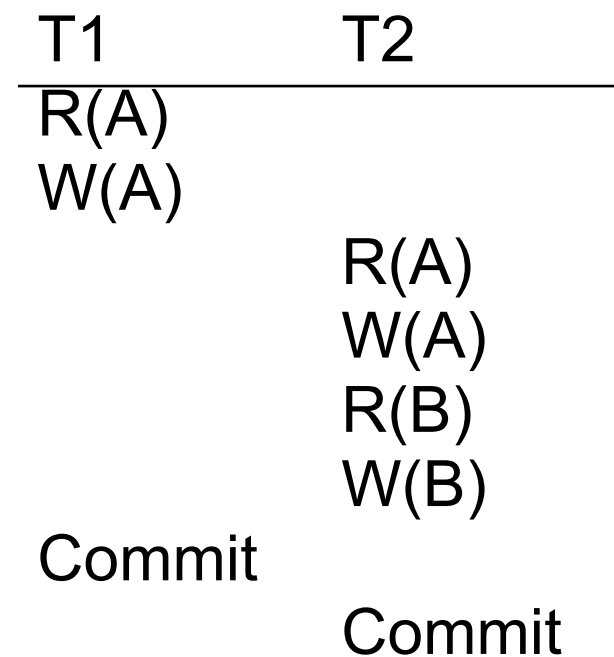
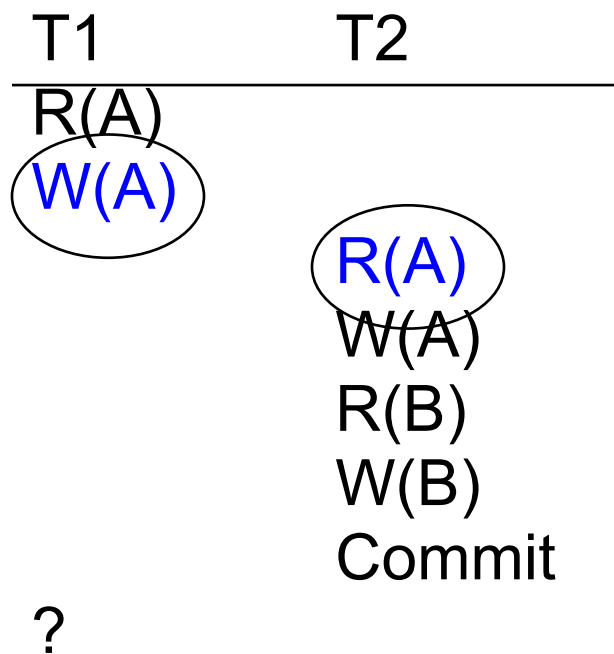

# Recoverable Schedules

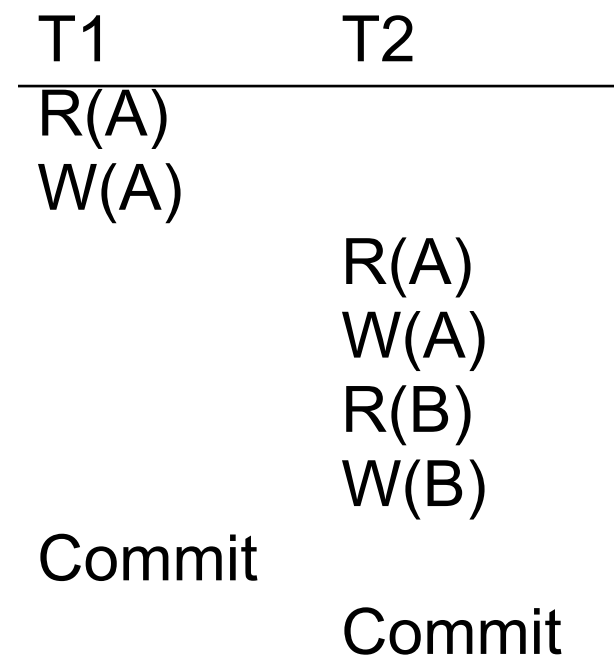
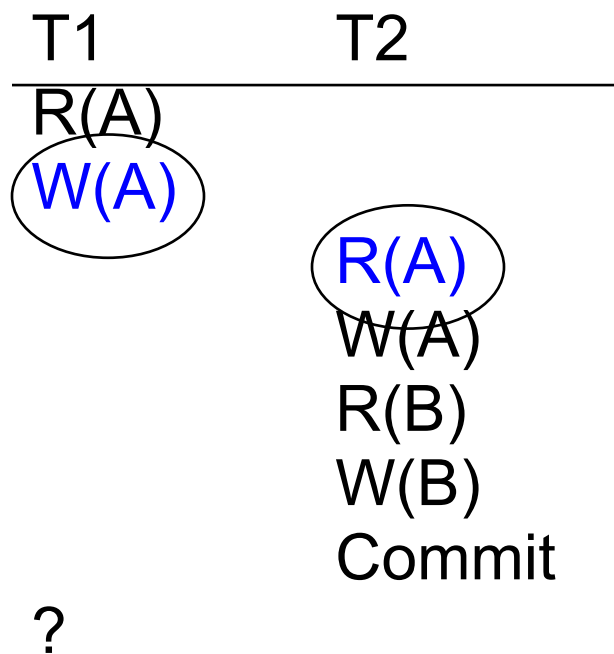

Nonrecoverable

# Recoverable Schedules

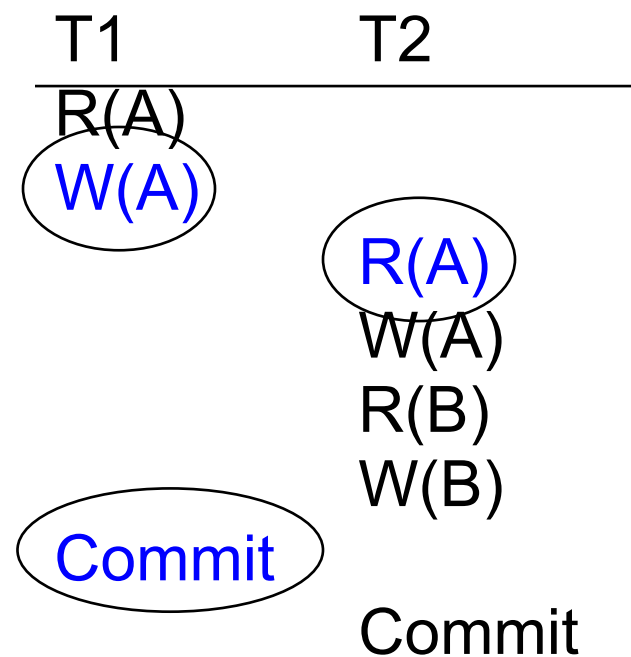
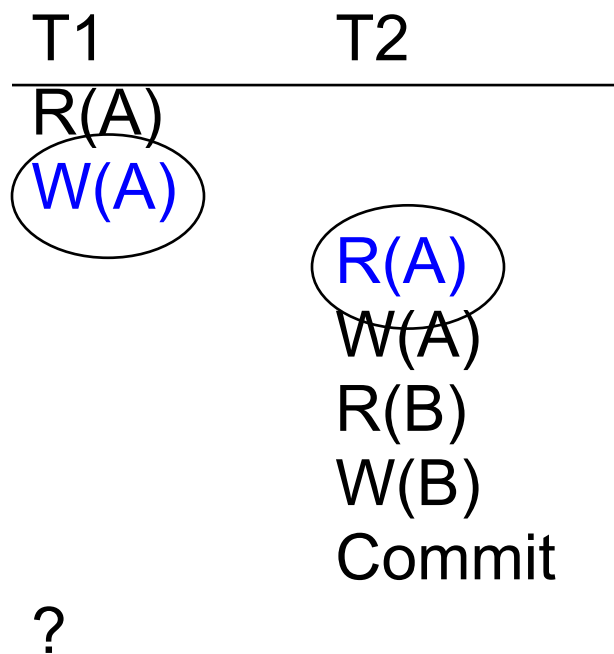

Nonrecoverable

# Recoverable Schedules

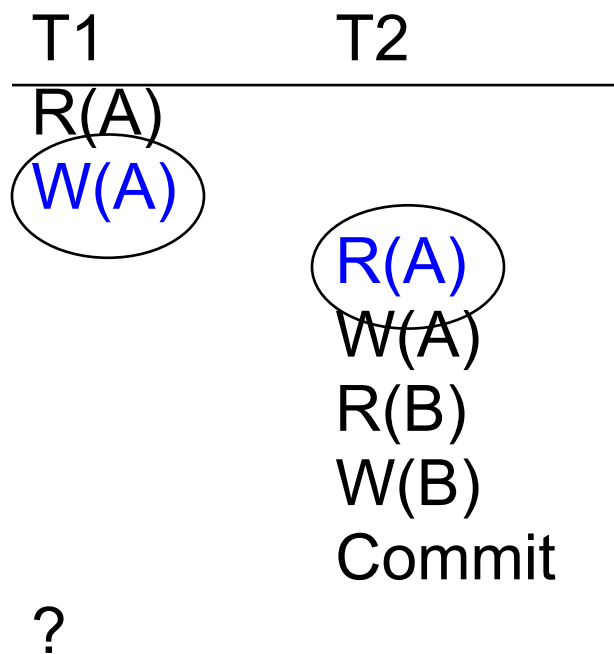

Nonrecoverable

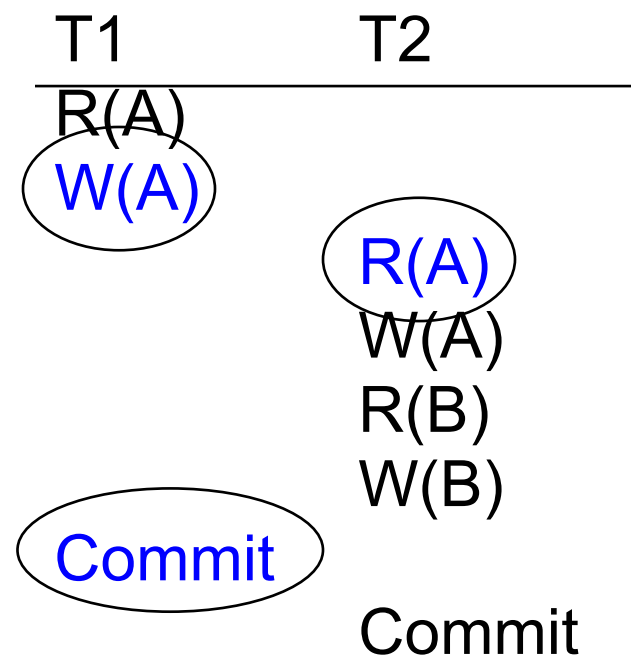

Recoverable

# Recoverable Schedules

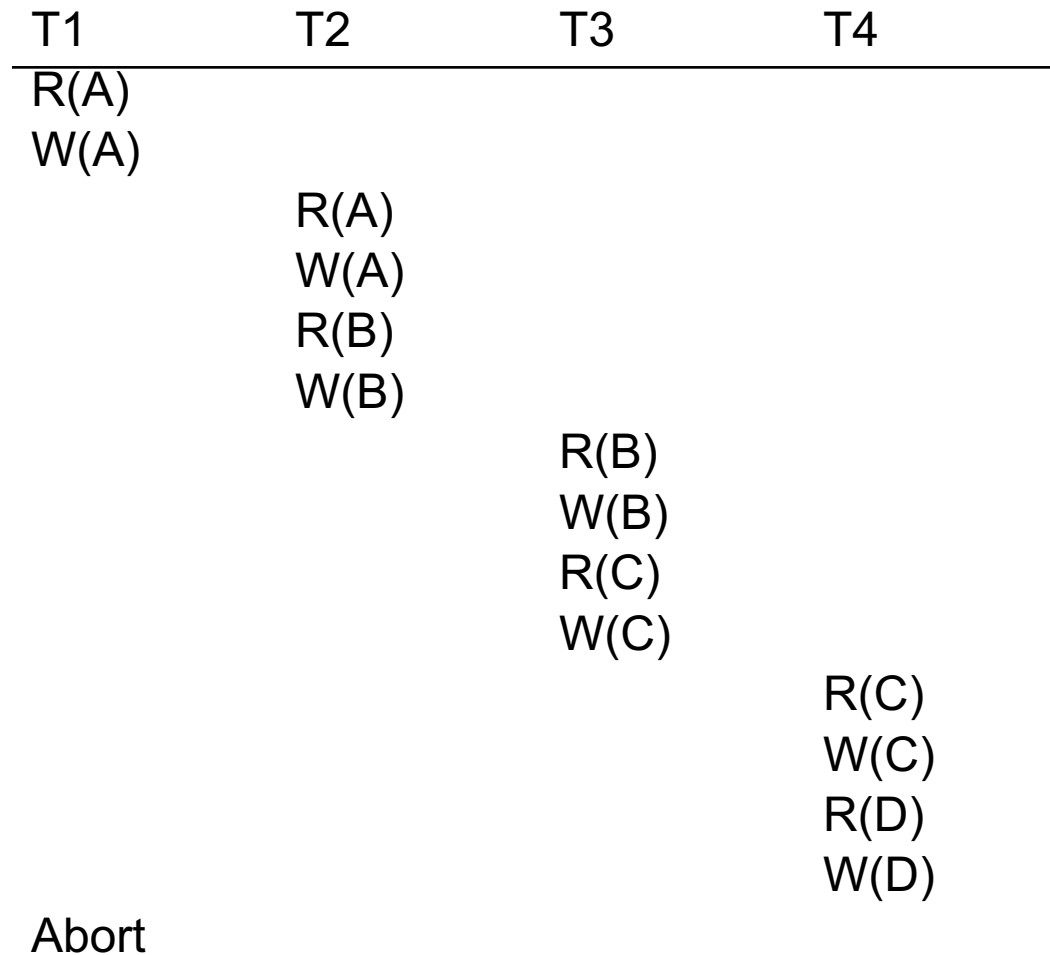

How do we recover ?

# Recoverable Schedules

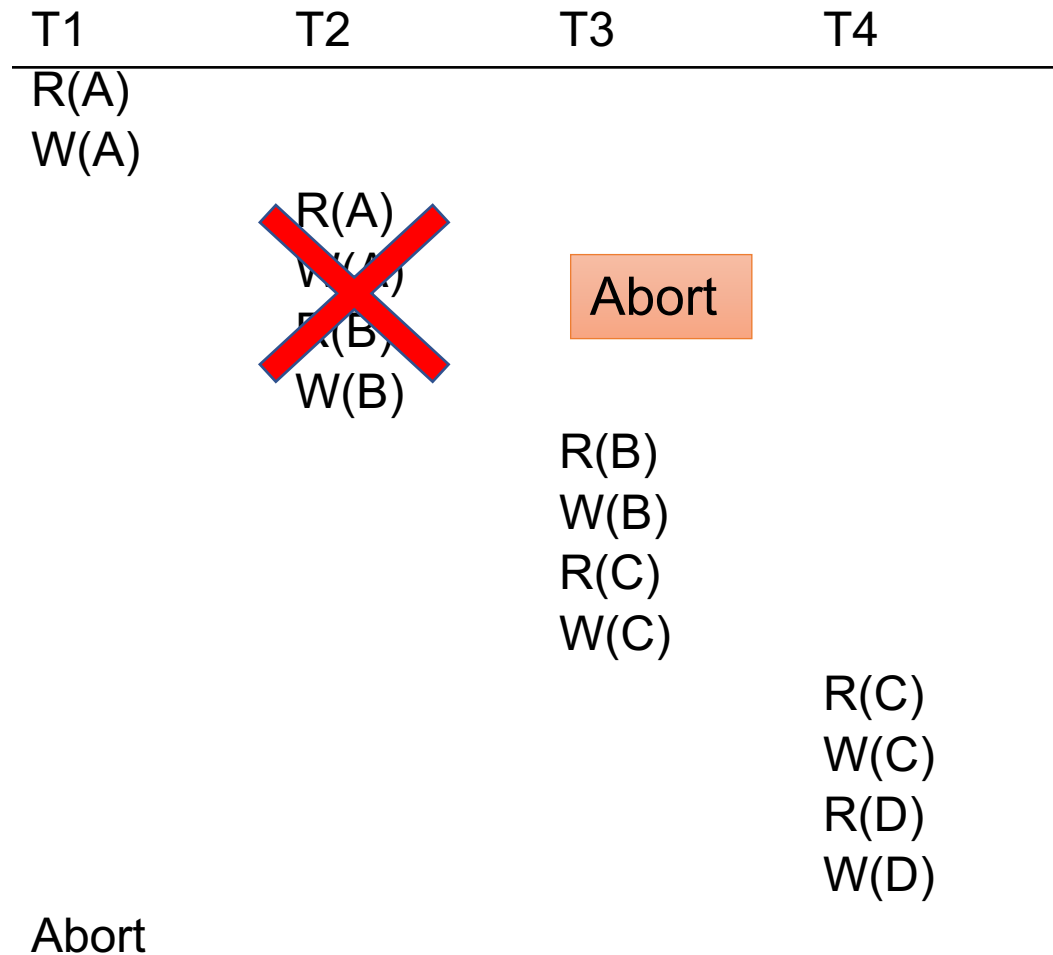

How do we recover ?

# Recoverable Schedules

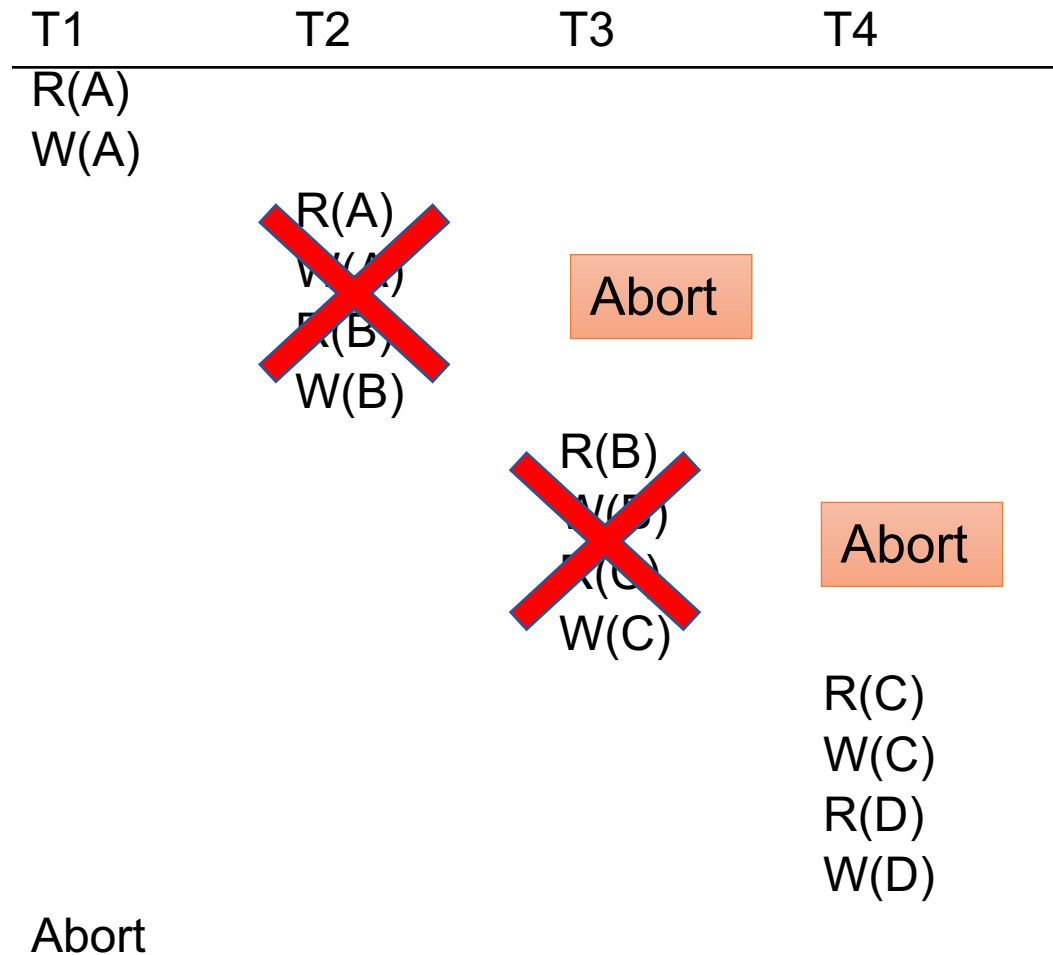

How do we recover ?

# Recoverable Schedules

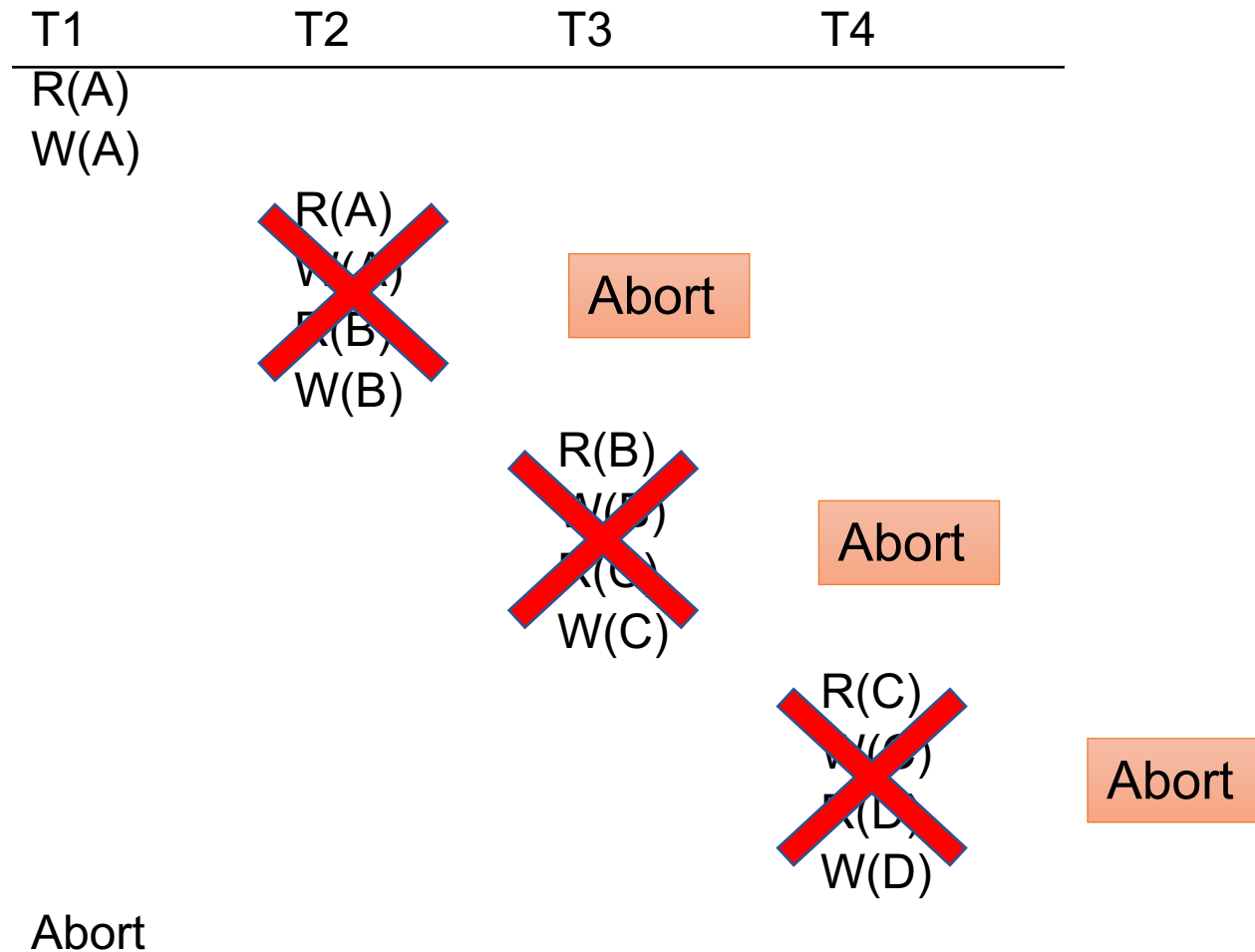

How do we recover ?

# Cascading Aborts

- If a transaction  $T$  aborts, then we need to abort any other transaction  $T'$  that has read an element written by  $T$
- A schedule *avoids cascading aborts* if whenever a transaction reads an element, the transaction that has *last written* it has *already committed*.

We base our locking scheme on this rule!

# Avoiding Cascading Aborts

T1	T2
R(A)	
W(A)	
	R(A)
	W(A)
	R(B)
	W(B)
...	

With cascading aborts

T1	T2
R(A)	
W(A)	
Commit	
	R(A)
	W(A)
	R(B)
	W(B)
	...

Without cascading aborts

## Serializability

- Serial
- Serializable
- Conflict serializable
- View serializable

## Recoverability

- Recoverable
- Avoids cascading aborts

# Terminology Needed For Lab 3

- **STEAL or NO-STEAL**

- When can we evict dirty pages from the buffer pool?

- **FORCE or NO-FORCE**

- When do we need to synchronize updates made by a transaction relative to commit time?

# Terminology Needed For Lab 3

- **STEAL or NO-STEAL**

- When can we evict dirty pages from the buffer pool?

- **FORCE or NO-FORCE**

- When do we need to synchronize updates made by a transaction relative to commit time?

- Easiest for recovery: NO-STEAL/FORCE (lab 3)