

# Database System Internals

## External Memory Algorithms (part 3)

Paul G. Allen School of Computer Science and Engineering  
University of Washington, Seattle

# Index Based Selection

- **Example:**

$$\begin{aligned} B(R) &= 2000 \\ T(R) &= 100,000 \\ V(R, a) &= 20 \end{aligned}$$

$$\text{cost of } \sigma_{a=v}(R) = ?$$

- **Table scan:**
- **Index based selection:**

# Index Based Selection

- **Example:**

$$\begin{aligned} B(R) &= 2000 \\ T(R) &= 100,000 \\ V(R, a) &= 20 \end{aligned}$$

$$\text{cost of } \sigma_{a=v}(R) = ?$$

- Table scan:  $B(R) = 2,000$  I/Os
- Index based selection:

# Index Based Selection

- **Example:**

$$\begin{aligned} B(R) &= 2000 \\ T(R) &= 100,000 \\ V(R, a) &= 20 \end{aligned}$$

$$\text{cost of } \sigma_{a=v}(R) = ?$$

- **Table scan:**  $B(R) = 2,000$  I/Os
- **Index based selection:**
  - If index is clustered:
  - If index is unclustered:

# Index Based Selection

- **Example:**

$$\begin{aligned} B(R) &= 2000 \\ T(R) &= 100,000 \\ V(R, a) &= 20 \end{aligned}$$

$$\text{cost of } \sigma_{a=v}(R) = ?$$

- **Table scan:**  $B(R) = 2,000$  I/Os
- **Index based selection:**
  - If index is clustered:
  - If index is unclustered:  $T(R)/V(R,a) = 5,000$  I/Os

# Index Based Selection

- **Example:**

$$\begin{aligned} B(R) &= 2000 \\ T(R) &= 100,000 \\ V(R, a) &= 20 \end{aligned}$$

$$\text{cost of } \sigma_{a=v}(R) = ?$$

- **Table scan:**  $B(R) = 2,000$  I/Os
- **Index based selection:**
  - If index is clustered:  $B(R)/V(R,a) = 100$  I/Os
  - If index is unclustered:  $T(R)/V(R,a) = 5,000$  I/Os

# Index Based Selection

- **Example:**

$$\begin{aligned} B(R) &= 2000 \\ T(R) &= 100,000 \\ V(R, a) &= 20 \end{aligned}$$

$$\text{cost of } \sigma_{a=v}(R) = ?$$

- **Table scan:**  $B(R) = 2,000$  I/Os!
- **Index based selection:**
  - If index is clustered:  $B(R)/V(R,a) = 100$  I/Os
  - If index is unclustered:  $T(R)/V(R,a) = 5,000$  I/Os!

# Index Based Selection

- **Example:**

$$\begin{aligned} B(R) &= 2000 \\ T(R) &= 100,000 \\ V(R, a) &= 20 \end{aligned}$$

$$\text{cost of } \sigma_{a=v}(R) = ?$$

- **Table scan:**  $B(R) = 2,000$  I/Os!
- **Index based selection:**
  - If index is clustered:  $B(R)/V(R,a) = 100$  I/Os
  - If index is unclustered:  $T(R)/V(R,a) = 5,000$  I/Os!

Lesson: Don't build unclustered indexes when  $V(R,a)$  is small !

# Index Nested Loop Join

$R \bowtie S$

- Assume  $S$  has an index on the join attribute
- Iterate over  $R$ , for each tuple fetch corresponding tuple(s) from  $S$

# Index Nested Loop Join

$R \bowtie S$

- Assume  $S$  has an index on the join attribute
- Iterate over  $R$ , for each tuple fetch corresponding tuple(s) from  $S$
  
- Cost of nested loop join
  - $B(R) + T(R) * B(S)$
- **Cost of Index Nested Loop Join:**
  - If index on  $S$  is clustered:
  - If index on  $S$  is unclustered:

# Index Nested Loop Join

$R \bowtie S$

- Assume  $S$  has an index on the join attribute
- Iterate over  $R$ , for each tuple fetch corresponding tuple(s) from  $S$
  
- Cost of nested loop join
  - $B(R) + T(R) * B(S)$
- **Cost of Index Nested Loop Join:**
  - If index on  $S$  is clustered:
  - If index on  $S$  is unclustered:  $B(R) + T(R)T(S)/V(S,a)$

# Index Nested Loop Join

$R \bowtie S$

- Assume  $S$  has an index on the join attribute
- Iterate over  $R$ , for each tuple fetch corresponding tuple(s) from  $S$
  
- Cost of nested loop join
  - $B(R) + T(R) * B(S)$
- **Cost of Index Nested Loop Join:**
  - If index on  $S$  is clustered:  $B(R) + T(R)B(S)/V(S,a)$
  - If index on  $S$  is unclustered:  $B(R) + T(R)T(S)/V(S,a)$

# Outline

- **Join operator algorithms**
  - One-pass algorithms (Sec. 15.2 and 15.3)
  - Index-based algorithms (Sec 15.6)
  - Two-pass algorithms (Sec 15.4 and 15.5)

# Two-Pass Algorithms

- Hash-join, merge-join assumed data  $\leq$  memory
- Next: algorithm when the data  $\gg$  main memory  
Called external memory algorithm
- Merge-join
- Partitioned hash-join

# Questions

- What is the “best” algorithm for sorting an array of  $n$  elements in main memory?
- What is its runtime?
- What is the best algorithm for sorting a large file of  $n$  items on disc?
- What is its runtime?

# Questions

- What is the “best” algorithm for sorting an array of  $n$  elements in main memory?
  - Quicksort
- What is its runtime?
  
- What is the best algorithm for sorting a large file of  $n$  items on disc?
- What is its runtime?

# Questions

- What is the “best” algorithm for sorting an array of  $n$  elements in main memory?
  - Quicksort
- What is its runtime?
  - $O(n \log n)$
- What is the best algorithm for sorting a large file of  $n$  items on disc?
- What is its runtime?

# Questions

- What is the “best” algorithm for sorting an array of  $n$  elements in main memory?
  - Quicksort
- What is its runtime?
  - $O(n \log n)$
- What is the best algorithm for sorting a large file of  $n$  items on disc?
  - *Multi-way* Merge sort
- What is its runtime?
  - $O(n \log n)$  CPU time;  $O(B \log_M B)$  disk I/O's

# Questions

- What is the “best” algorithm for sorting an array of  $n$  elements in main memory?
  - Quicksort
- What is its runtime?
  - $O(n \log n)$
- What is the best algorithm for sorting a large file of  $n$  items on disc?
  - **Multi-way** Merge sort
- What is its runtime?
  - $O(n \log n)$  CPU time;  $O(B \log_M B)$  disk I/O's

Main memory merge-sort: **2-way**  
External memory merge-sort: **multi-way**

# Questions

- What is the “best” algorithm for sorting an array of  $n$  elements in main memory?
  - Quicksort
- What is its runtime?
  - $O(n \log n)$
- What is the best algorithm for sorting a large file of  $n$  items on disc?
  - **Multi-way** Merge sort
- What is its runtime?
  - $O(n \log n)$  CPU time;  $O(B \log_M B)$  disk I/O's

Main memory merge-sort: 2-way  
External memory merge-sort: multi-way

Merge-Join is based on the multi-way merge-sort (next)

# Merge-Sort: Basic Terminology

- A **run** in a sequence is an increasing subsequence
- What are the runs?

2, 4, 99, 103, 88, 77, 3, 79, 100, 2, 50

# Merge-Sort: Basic Terminology

- A **run** in a sequence is an increasing subsequence
- What are the runs?

2, 4, 99, 103, | 88, | 77, | 3, 79, 100, | 2, 50

# External Merge-Sort: Step 1

**Phase one:** load  $M$  blocks in memory, sort, send to disk, repeat

# External Merge-Sort: Step 1

**Phase one:** load  $M$  blocks in memory, sort, send to disk, repeat

Q: How long are the runs?

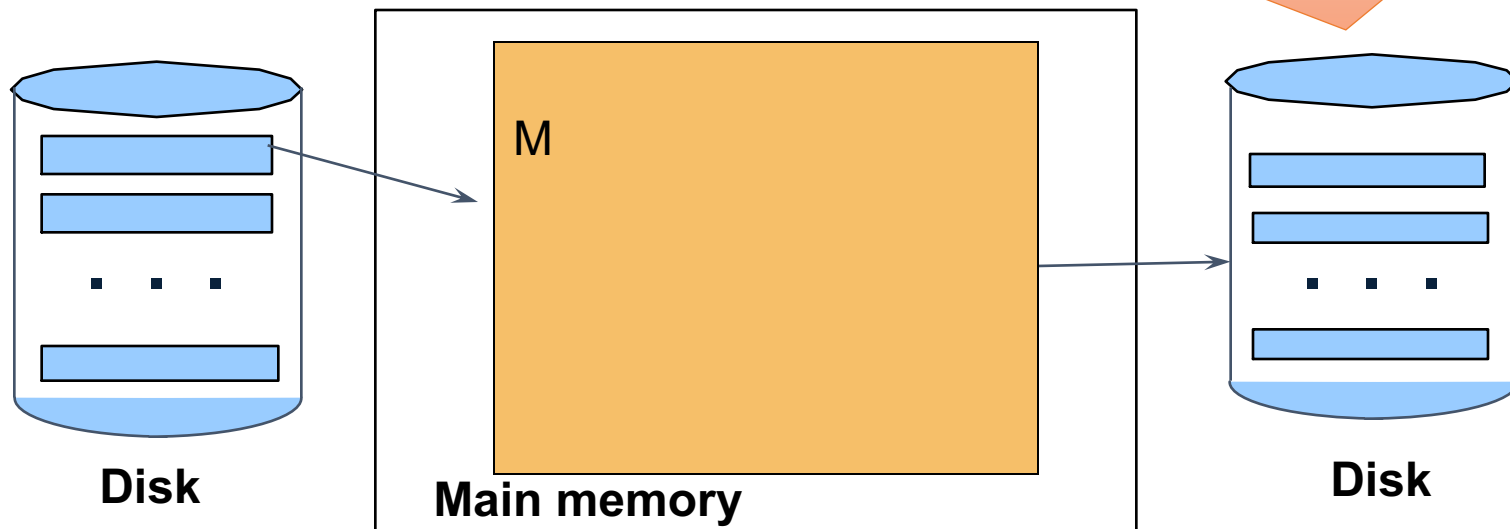

# External Merge-Sort: Step 1

**Phase one:** load  $M$  blocks in memory, sort, send to disk, repeat

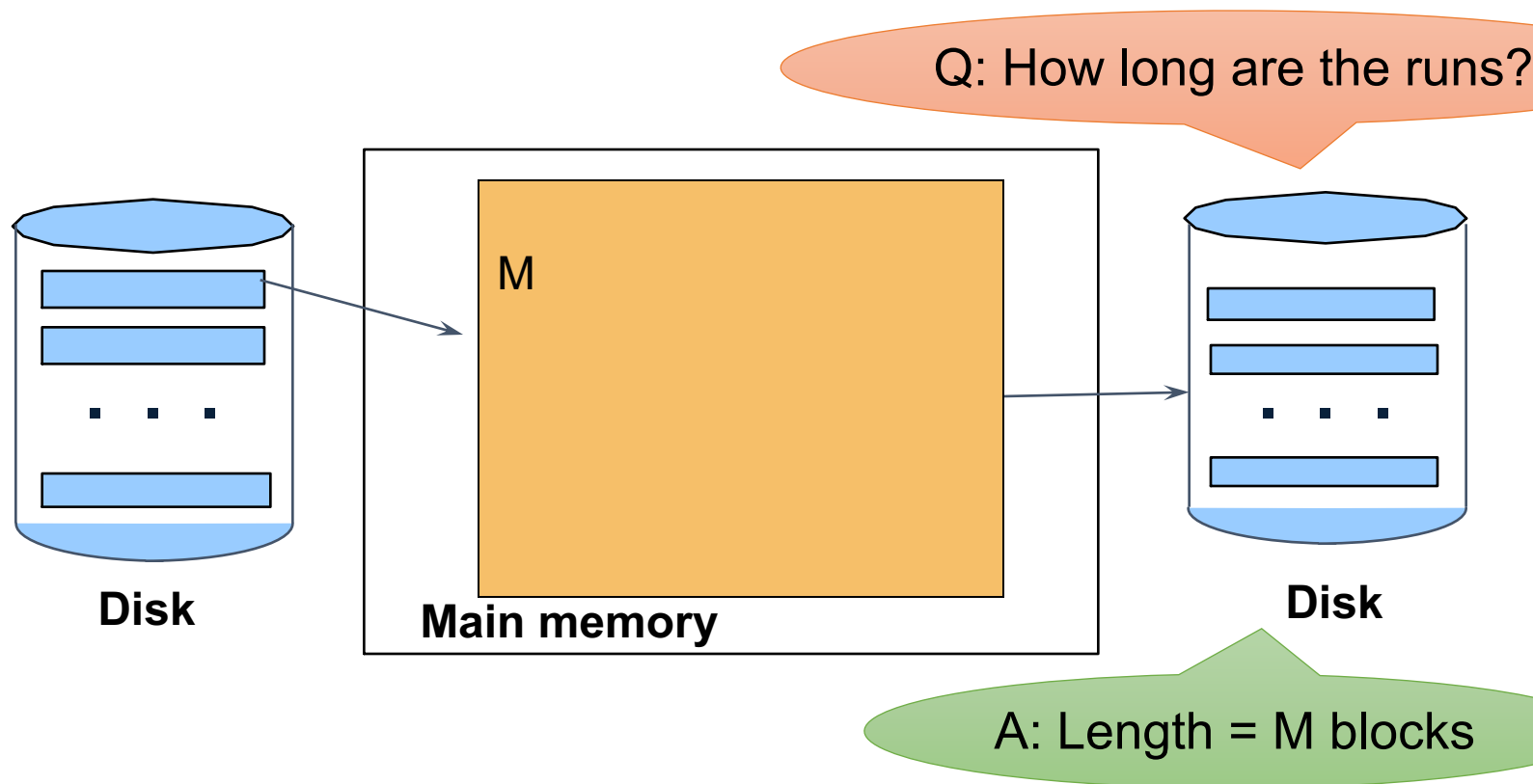

Phase two: merge  $M$  runs into a bigger run

- Merge  $M - 1$  runs into a new run
- Result: runs of length  $M(M - 1) \approx M^2$

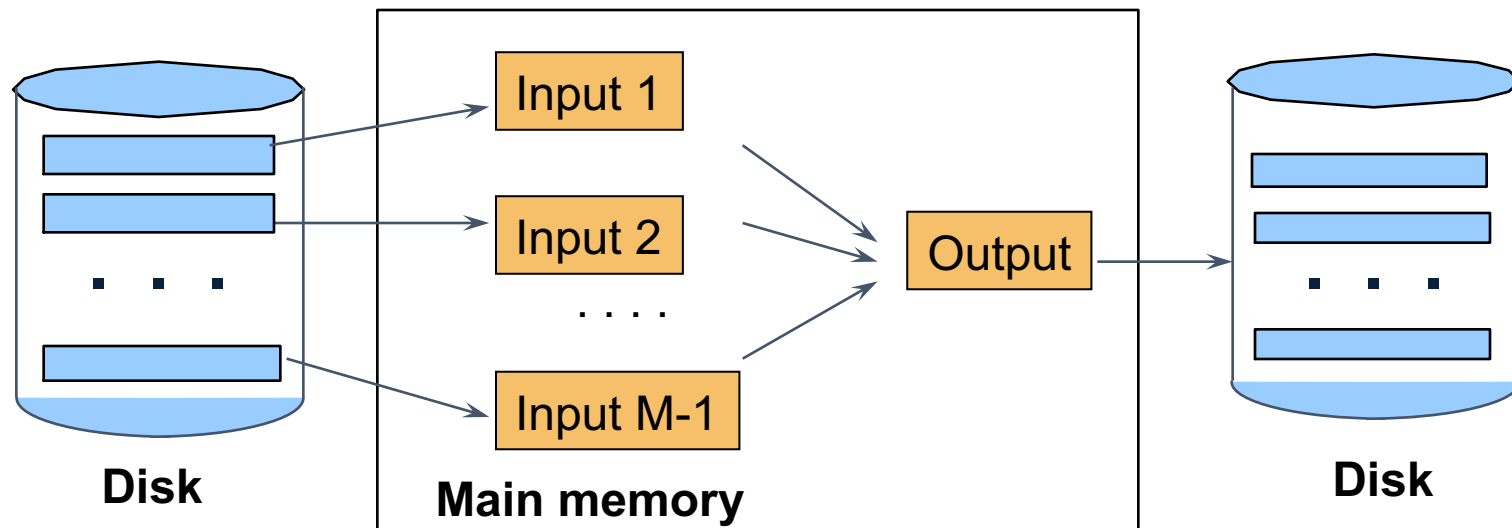

# Example

- Merging three runs to produce a longer run:

**0, 14, 33, 88, 92, 192, 322**

**2, 4, 7, 43, 78, 103, 523**

**1, 6, 9, 12, 33, 52, 88, 320**

Output:

**0**

# Example

- Merging three runs to produce a longer run:

0, **14**, 33, 88, 92, 192, 322

**2**, 4, 7, 43, 78, 103, 523

**1**, 6, 9, 12, 33, 52, 88, 320

Output:

0, **?**

# Example

- Merging three runs to produce a longer run:

0, **14**, 33, 88, 92, 192, 322

**2**, 4, 7, 43, 78, 103, 523

1, **6**, 9, 12, 33, 52, 88, 320

Output:

**0**, 1, **?**

# Example

- Merging three runs to produce a longer run:

0, **14**, 33, 88, 92, 192, 322

2, 4, 7, **43**, 78, 103, 523

1, 6, **9**, 12, 33, 52, 88, 320

Output:

0, 1, 2, 4, 6, 7, **?**

# External Merge-Sort: Step 2

**Phase two:** merge  $M$  runs into a bigger run

- Merge  $M - 1$  runs into a new run
- Result: runs of length  $M(M - 1) \approx M^2$

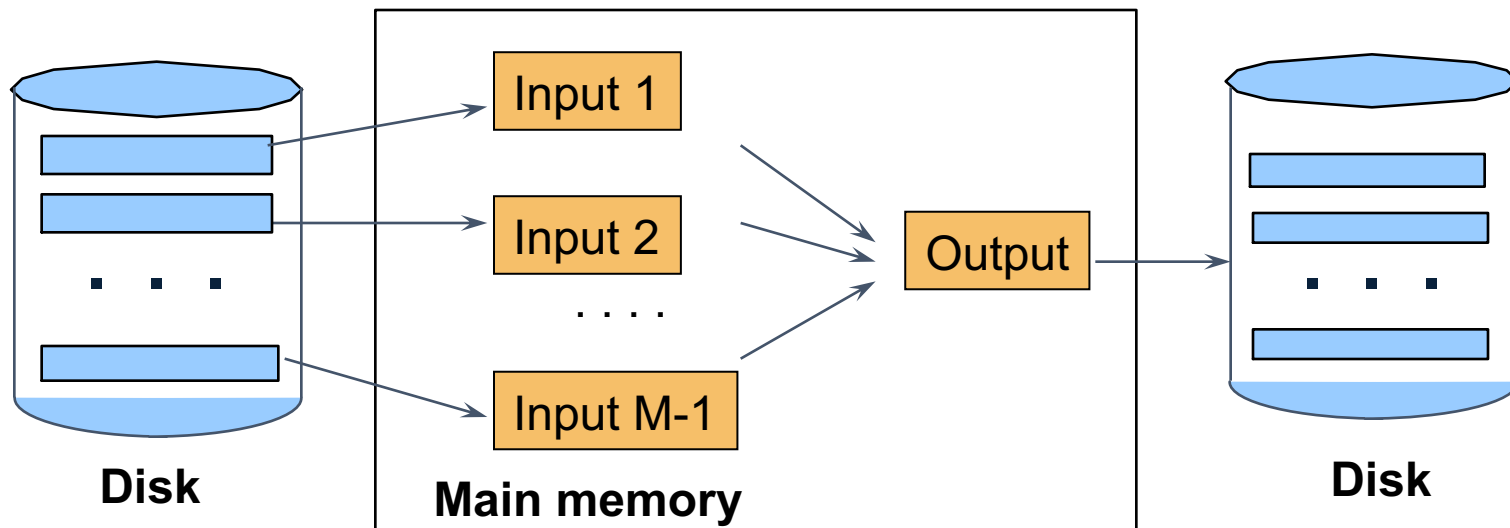

If approx.  $B \leq M^2$  then we are done

# Cost of External Merge Sort

In theory:

- Number of I/O's:  $O(B(R) * \log_M B(R))$

In practice:

- Assumption  $B(R) \leq M^2$
- Read+write+read =  $3B(R)$

# Discussion

- What does  $B(R) \leq M^2$  mean?
- How large can  $R$  be?

# Discussion

- What does  $B(R) \leq M^2$  mean?
- How large can  $R$  be?
  
- Example:
  - Page size = 32KB
  - Memory size 32GB:  $M = 10^6$ -pages

# Discussion

- What does  $B(R) \leq M^2$  mean?
- How large can  $R$  be?
  
- Example:
  - Page size = 32KB
  - Memory size 32GB:  $M = 10^6$  pages
  
- $R$  can be as large as  $10^{12}$  pages
  - $32 \times 10^{15}$  Bytes = 32 PB

# Merge-Join

Join  $R \bowtie S$

- How?.....

# Merge-Join

Join  $R \bowtie S$

- Step 1a: generate initial runs for R
- Step 1b: generate initial runs for S
- Step 2: merge and join
  - Either merge first and then join
  - Or merge & join at the same time

# Merge-Join Example

**Setup: Want to join R and S**

Relation R has 10 pages with 2 tuples per page

Relation S has 8 pages with 2 tuples per page

**Values shown are values of join attribute for each given tuple**

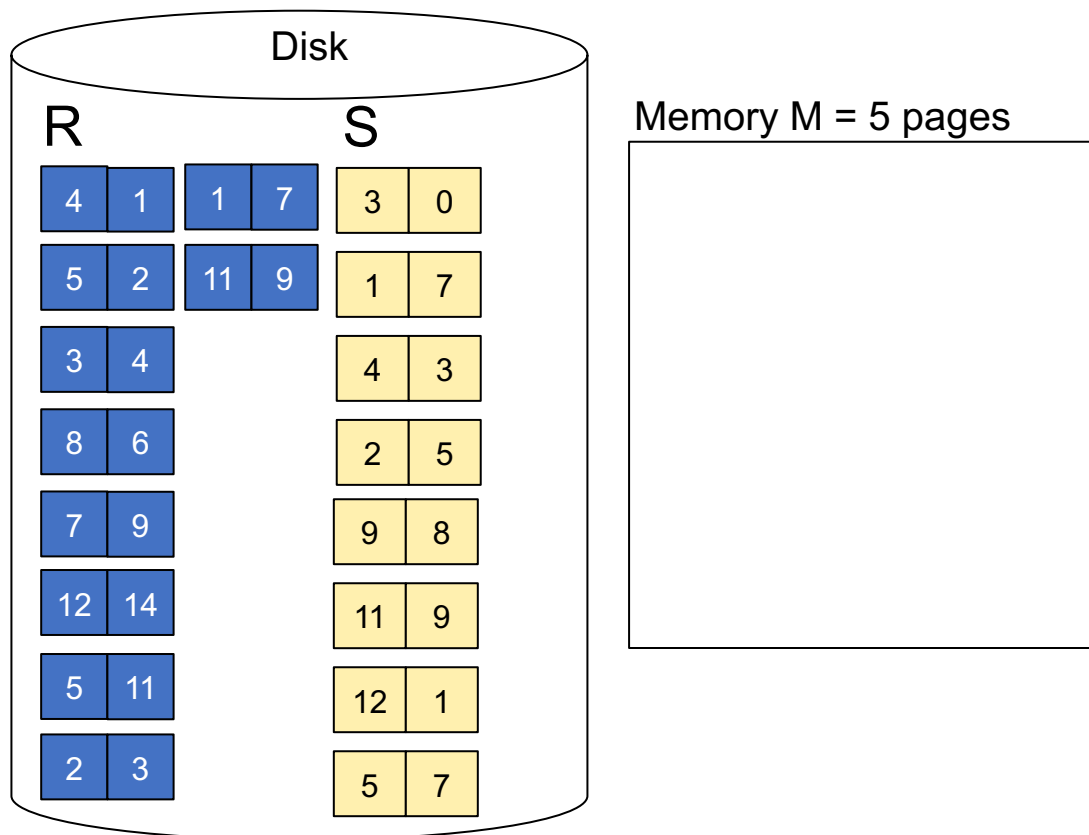

# Merge-Join Example

**Step 1:** Read M pages of R and sort in memory

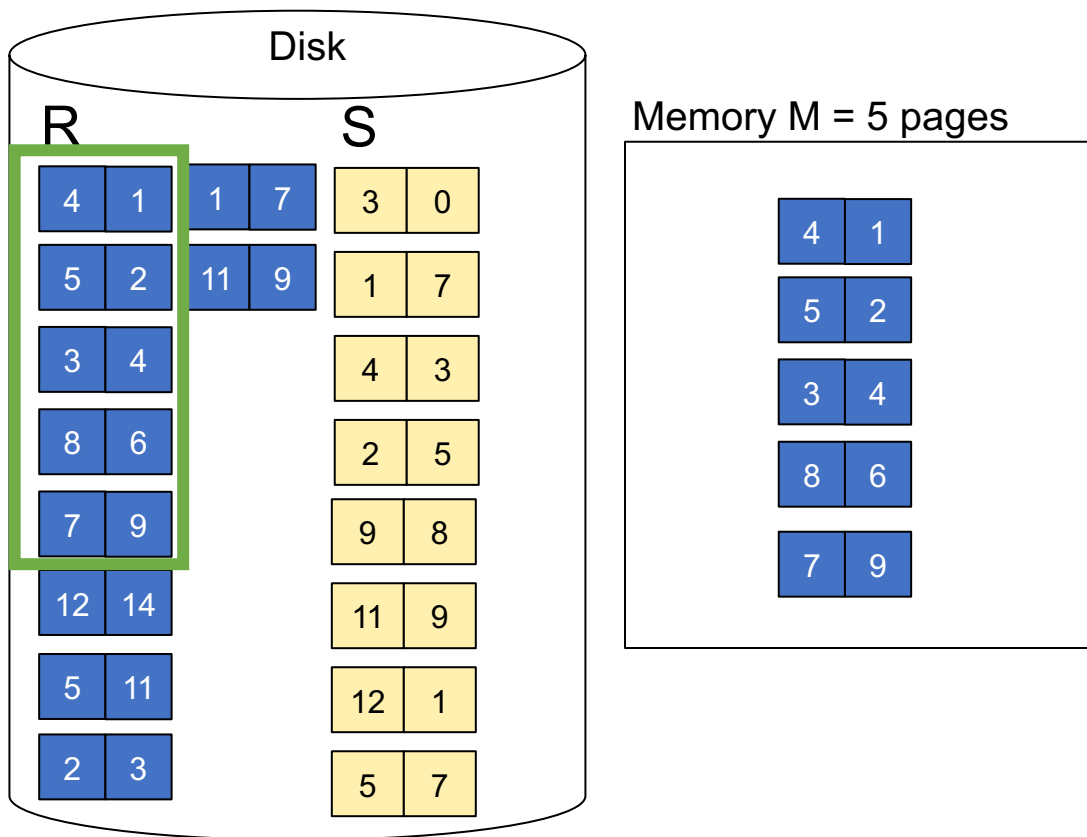

# Merge-Join Example

**Step 1:** Read M pages of R and sort in memory, then write to disk

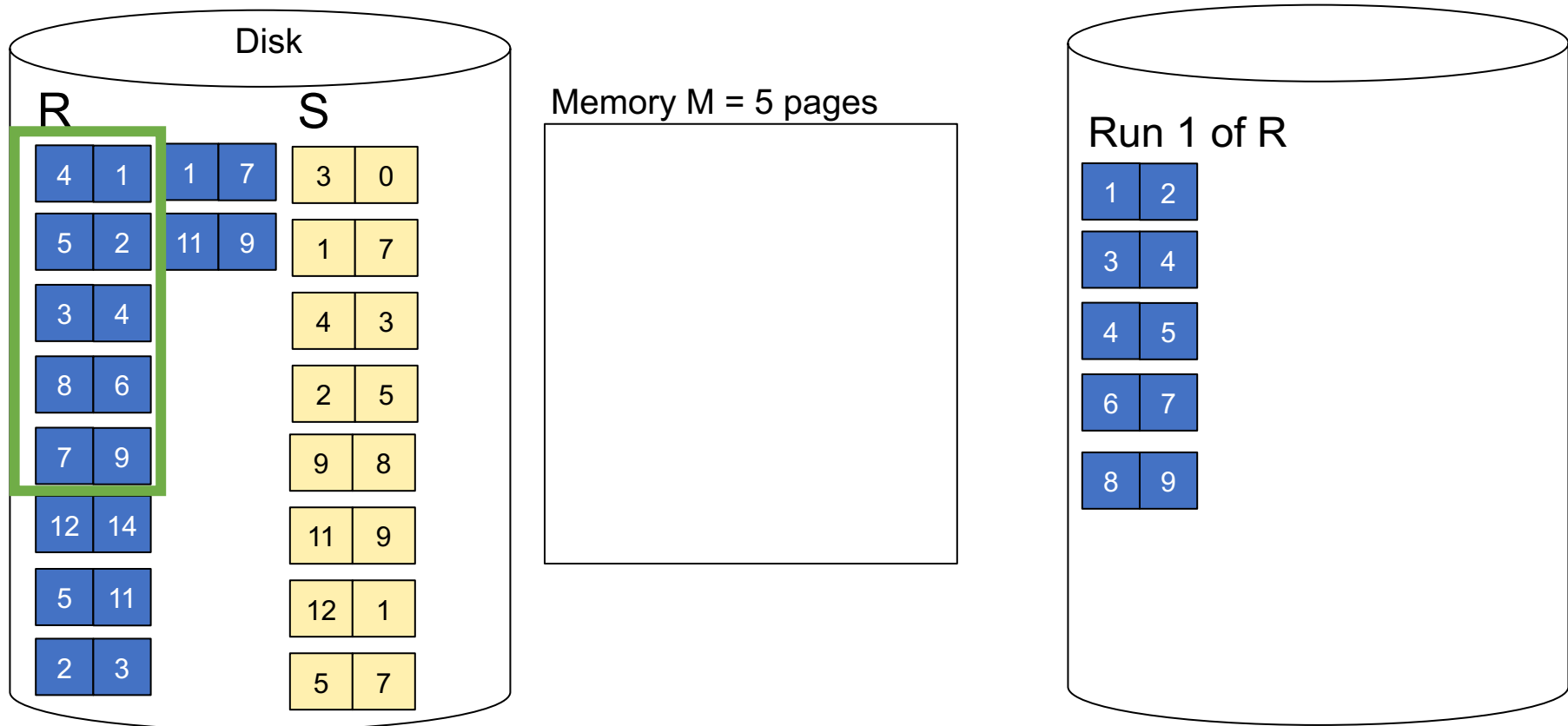

# Merge-Join Example

**Step 1:** Read M pages of R and sort in memory, then write to disk

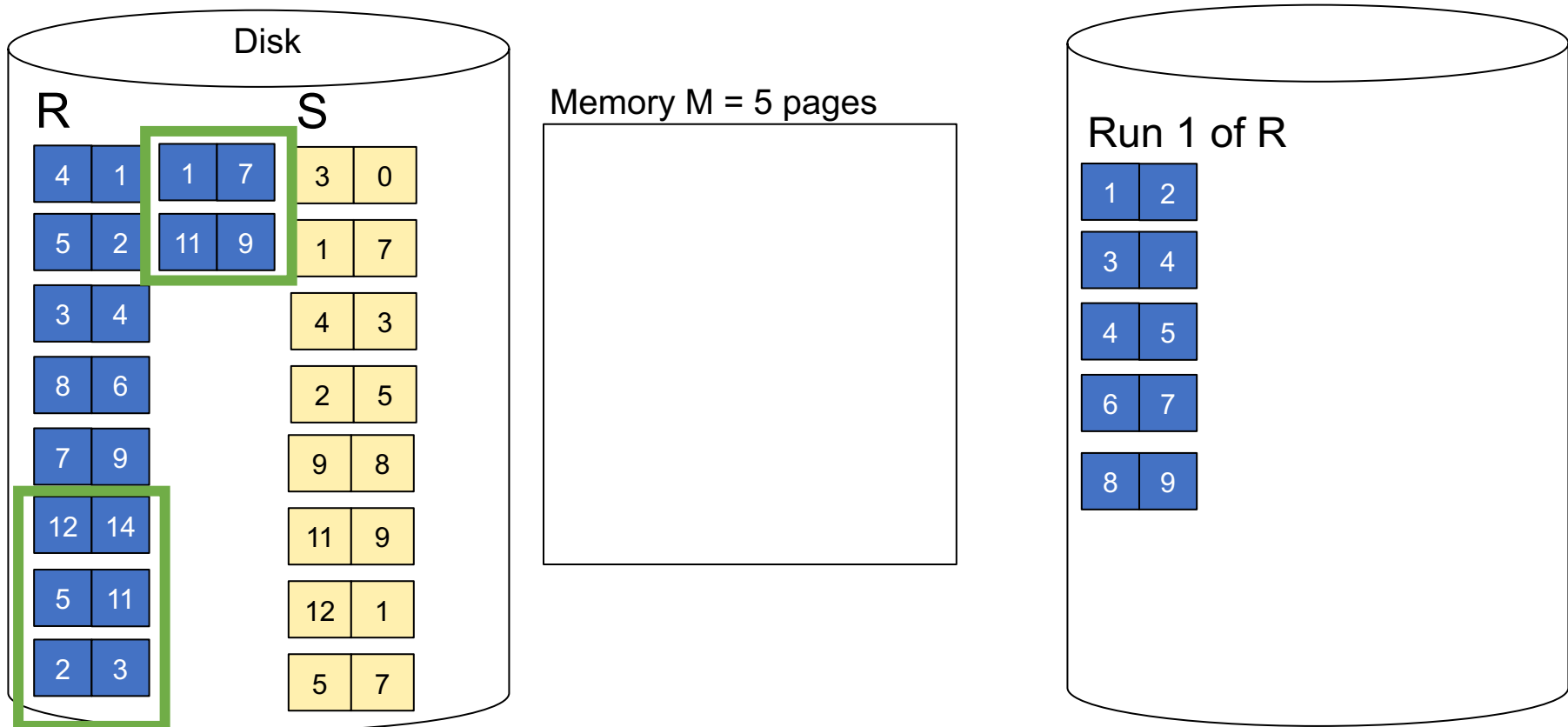

# Merge-Join Example

**Step 1:** Repeat for next M pages until all R is processed

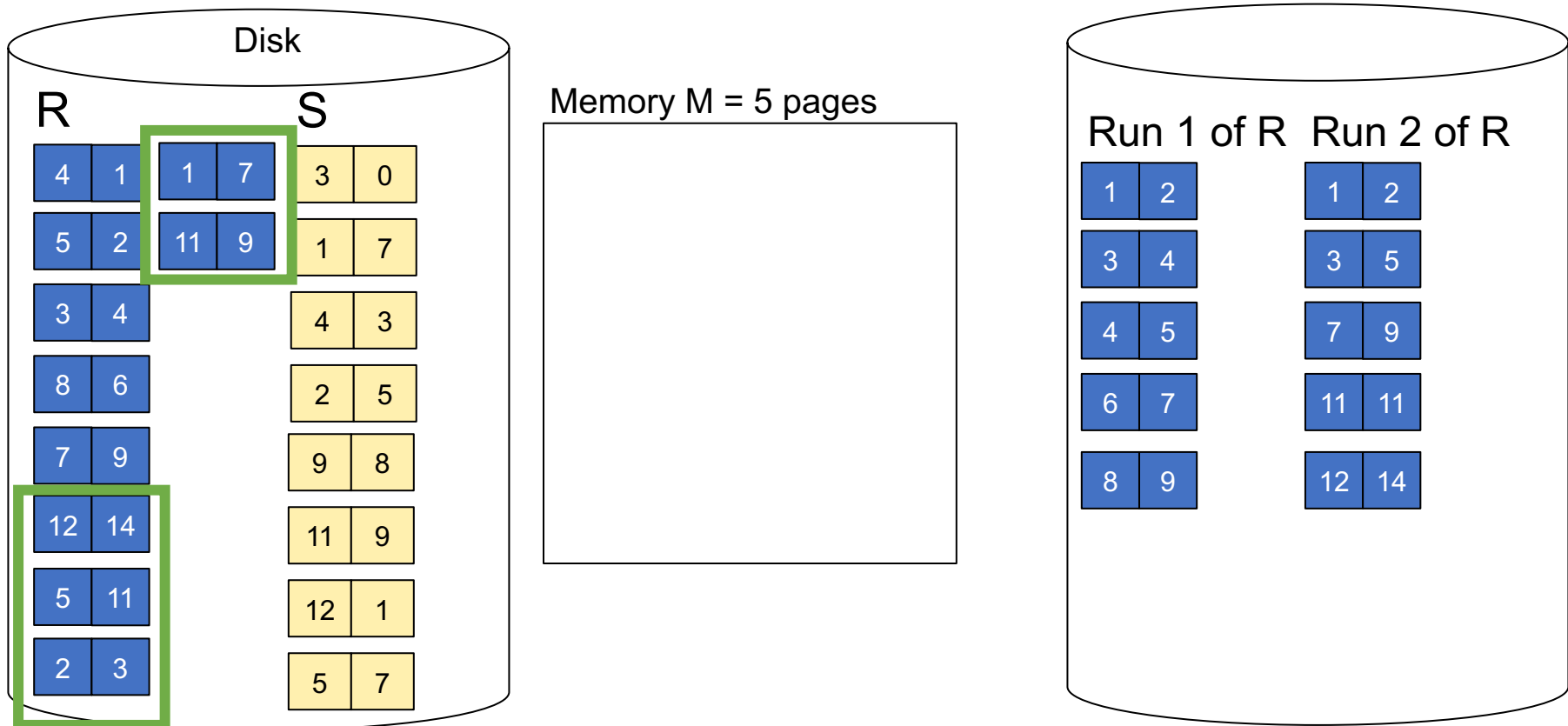

# Merge-Join Example

Step 1: Do the same with S

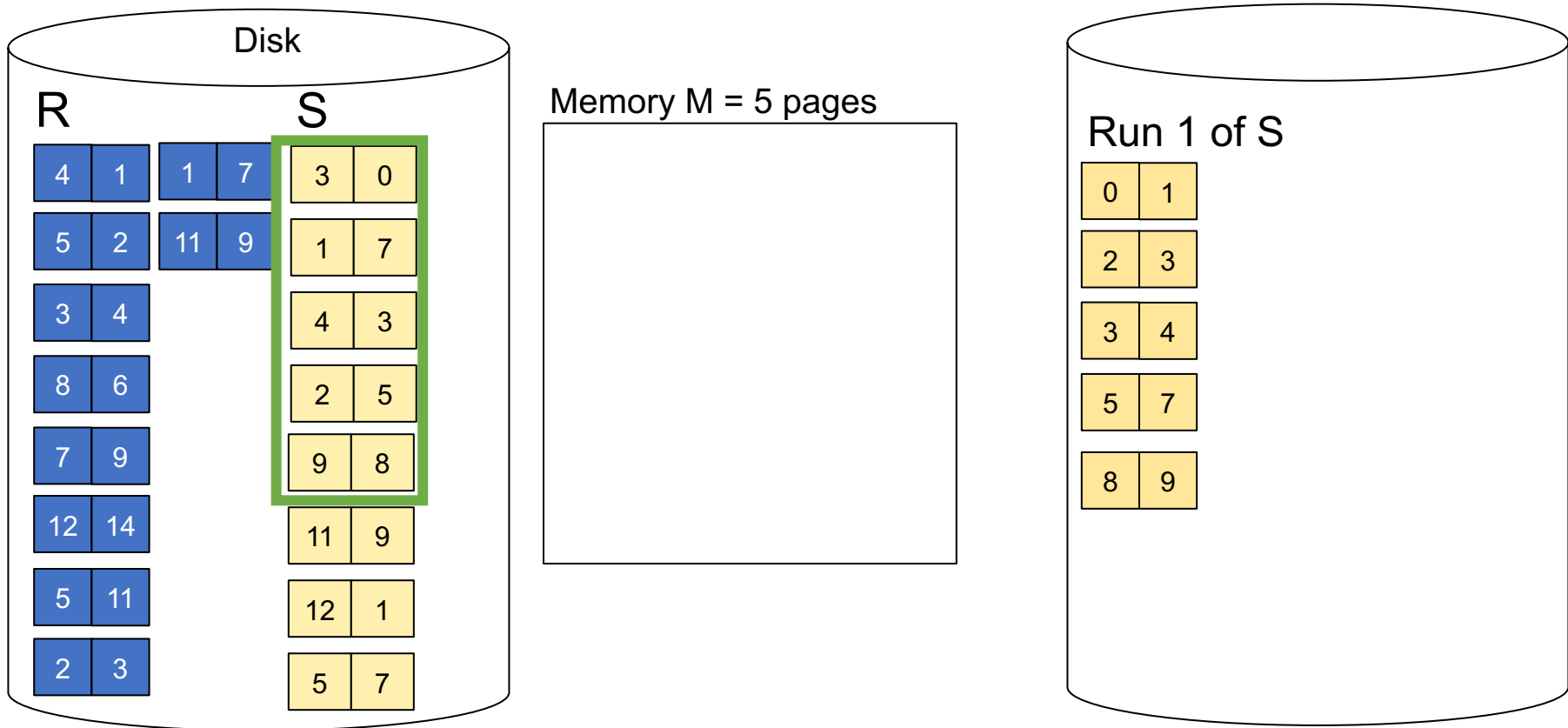

# Merge-Join Example

**Step 1:** Do the same with S

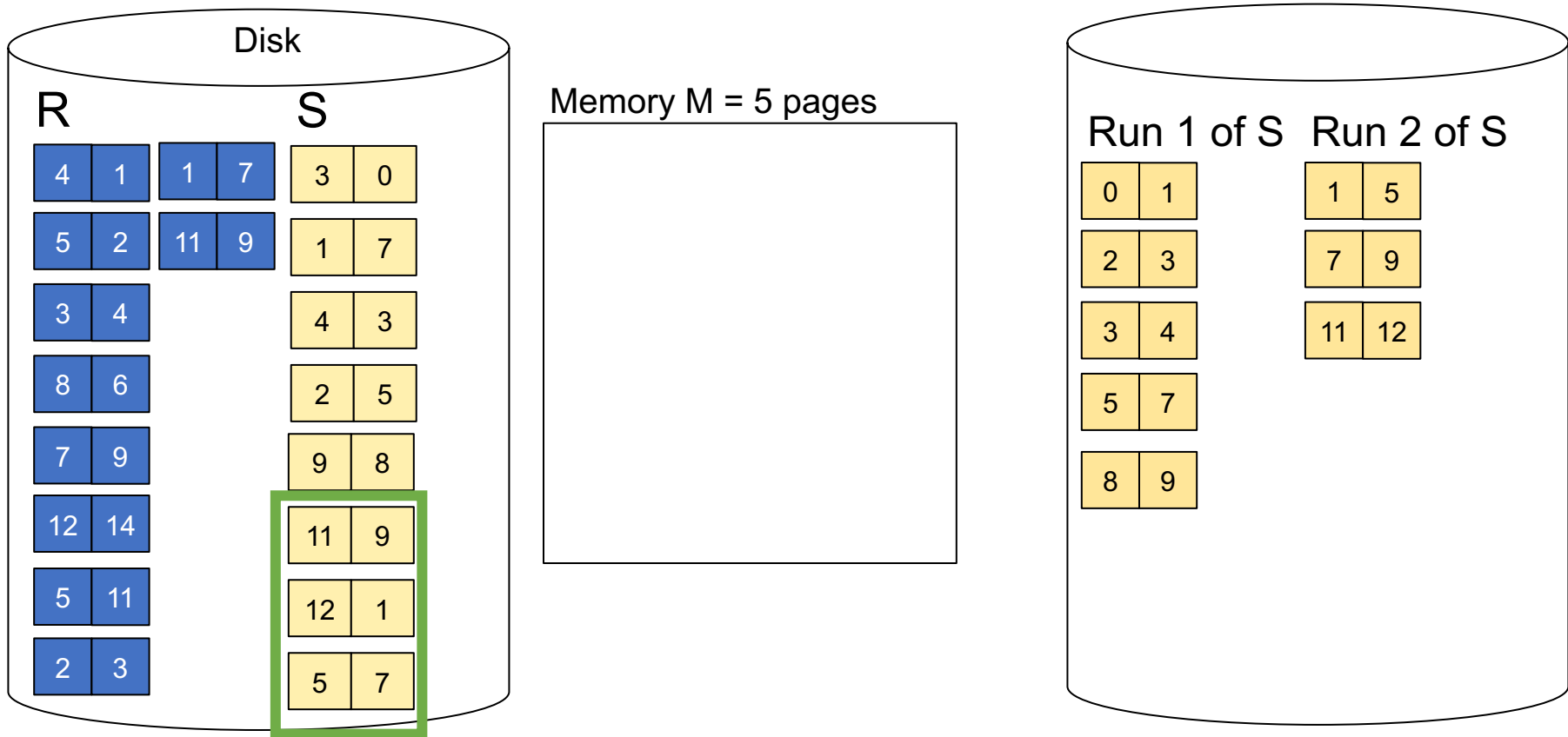

# Merge-Join Example

**Step 2:** Join while merging sorted runs

**Total cost:**  $3B(R) + 3B(S)$

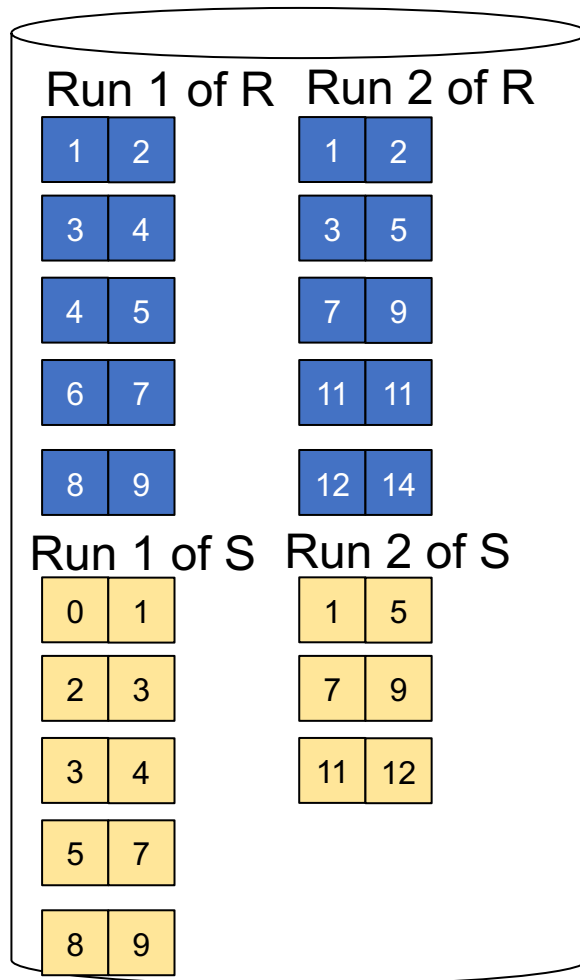

Memory M = 5 pages

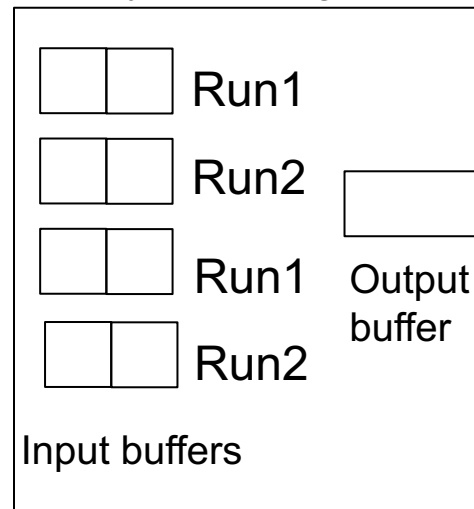

**Step 2:** Join while merging  
Output tuples

# Merge-Join Example

**Step 2:** Join while merging sorted runs

**Total cost:**  $3B(R) + 3B(S)$

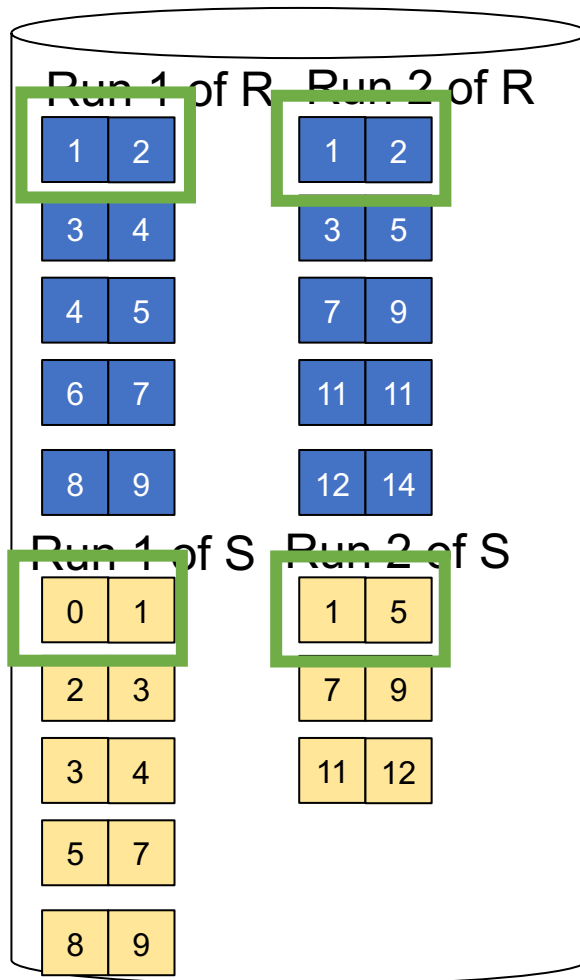

Memory  $M = 5$  pages

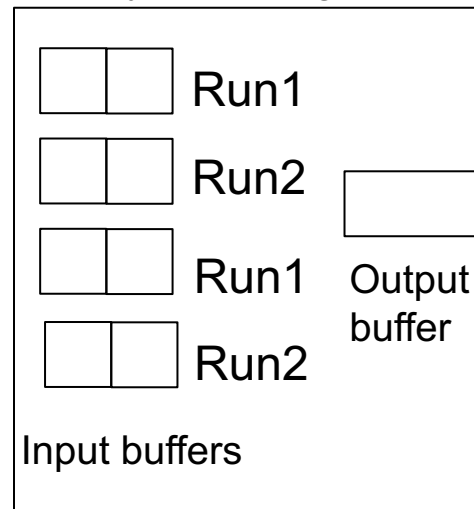

**Step 2:** Join while merging  
Output tuples

# Merge-Join Example

**Step 2:** Join while merging sorted runs

**Total cost:**  $3B(R) + 3B(S)$

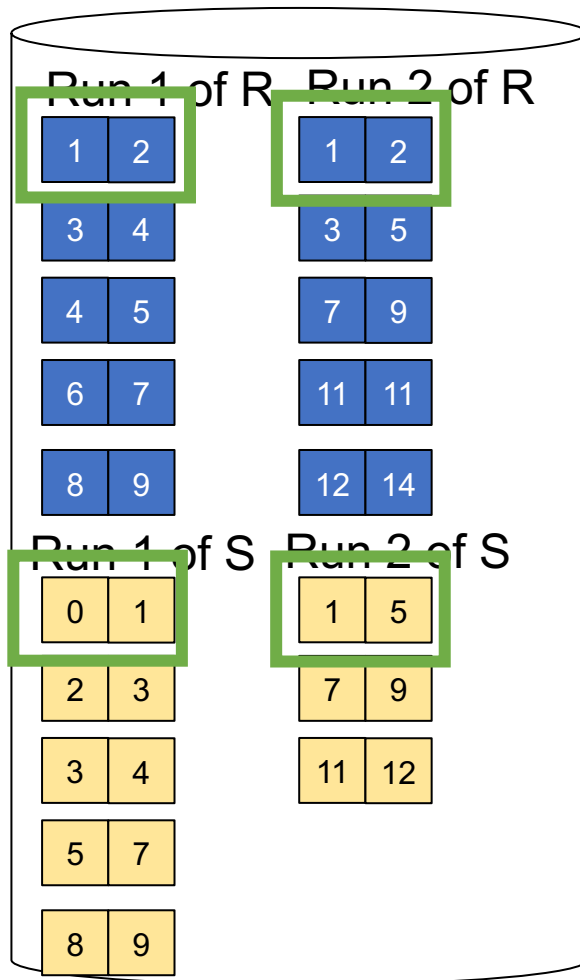

Memory M = 5 pages

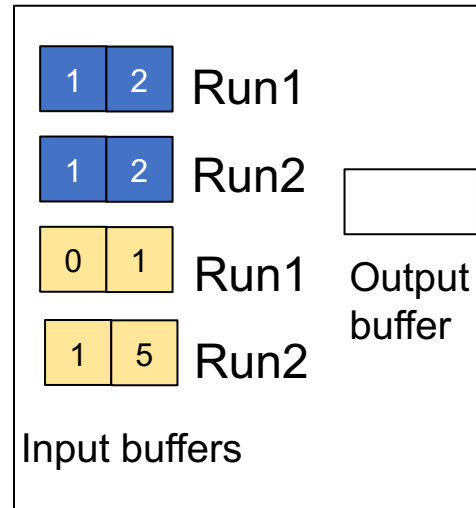

**Step 2:** Join while merging Output tuples

# Merge-Join Example

**Step 2:** Join while merging sorted runs

**Total cost:**  $3B(R) + 3B(S)$

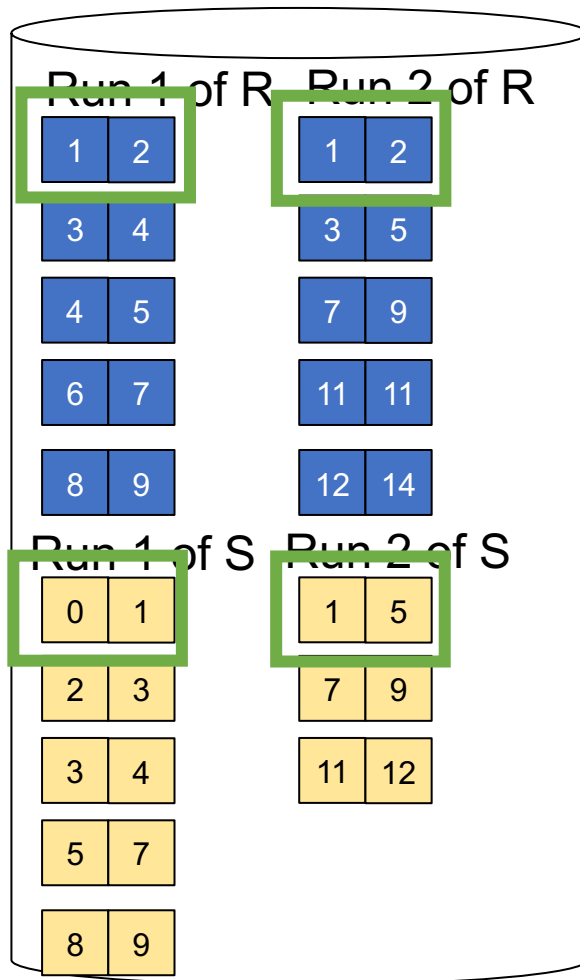

Memory M = 5 pages

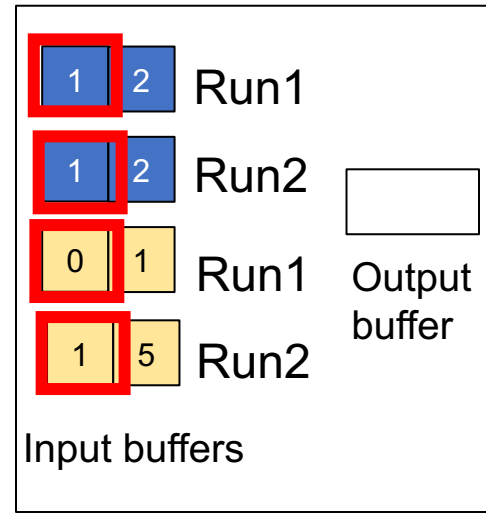

**Step 2:** Join while merging Output tuples

# Merge-Join Example

**Step 2:** Join while merging sorted runs

**Total cost:**  $3B(R) + 3B(S)$

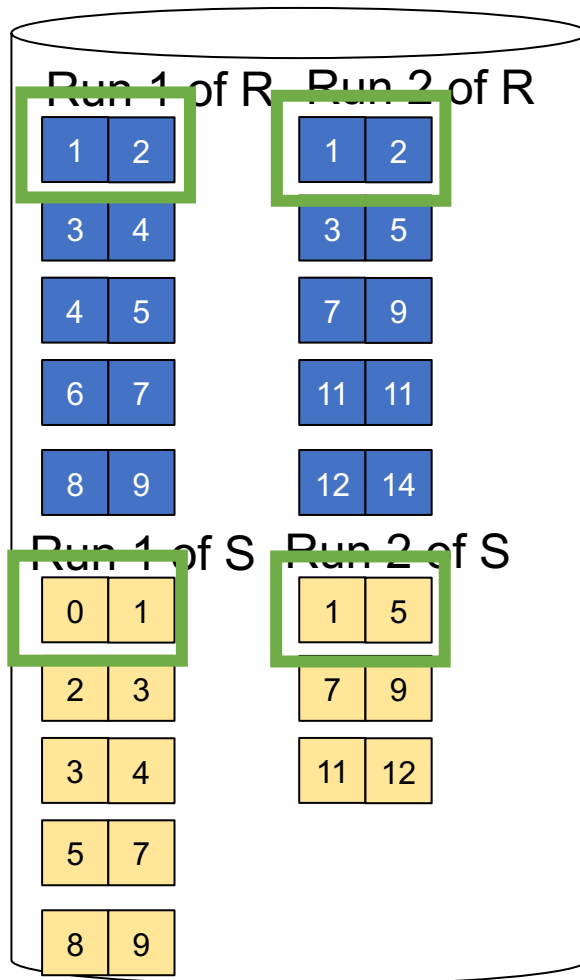

Memory M = 5 pages

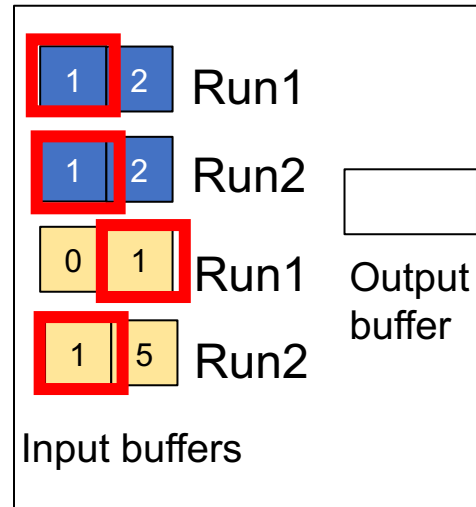

**Step 2:** Join while merging Output tuples

# Merge-Join Example

**Step 2:** Join while merging sorted runs

**Total cost:**  $3B(R) + 3B(S)$

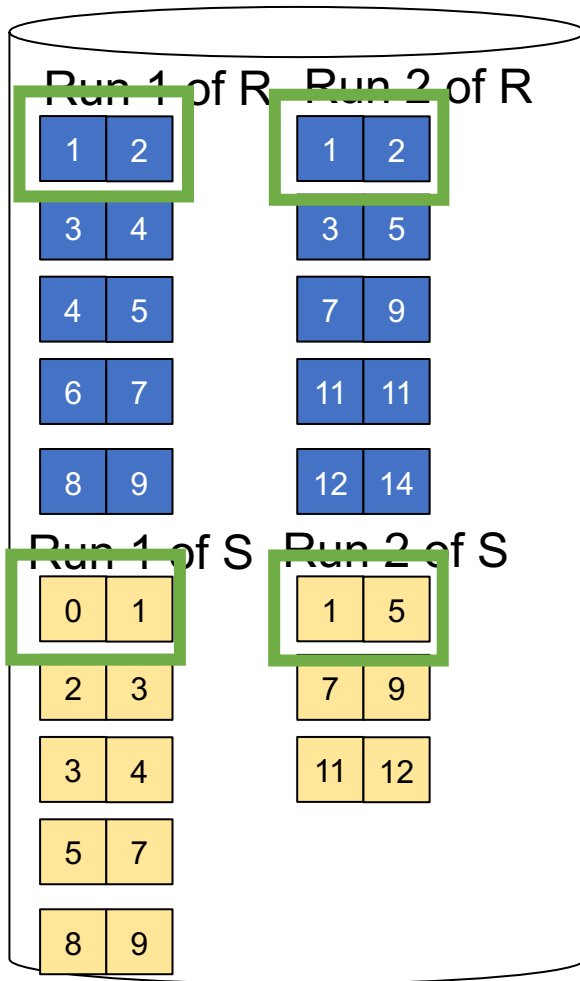

Memory M = 5 pages

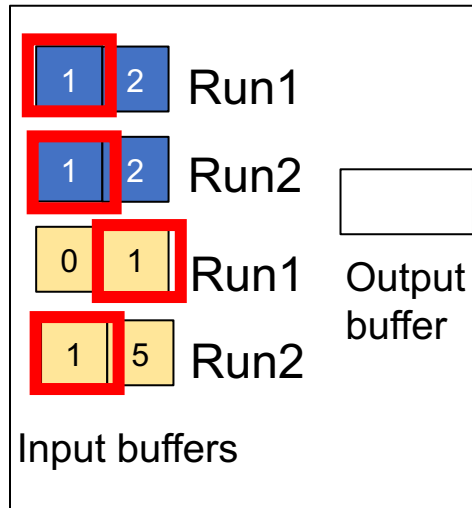

**Step 2:** Join while merging  
Output tuples

- (1,1)
- (1,1)
- (1,1)
- (1,1)

# Merge-Join Example

**Step 2:** Join while merging sorted runs

**Total cost:**  $3B(R) + 3B(S)$

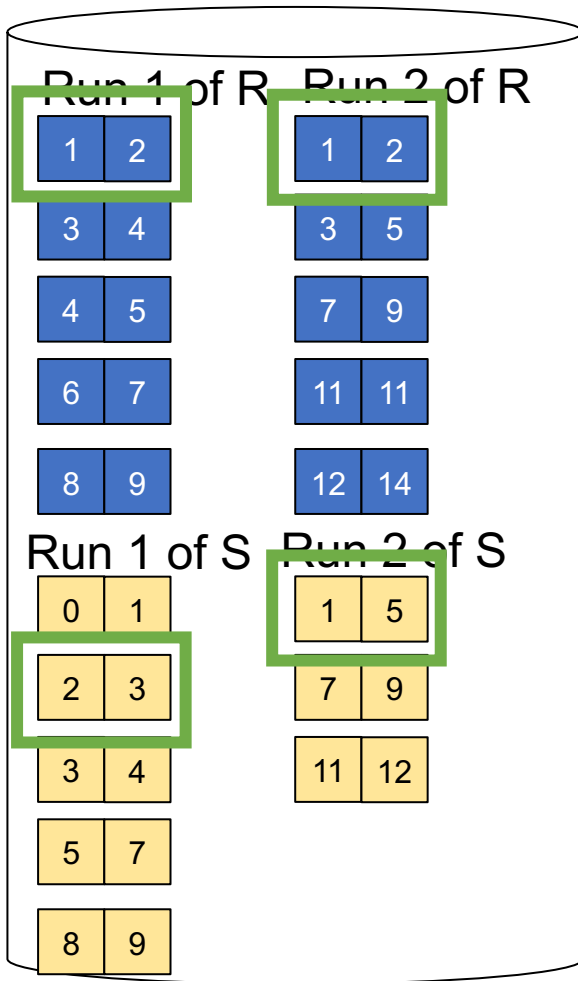

Memory  $M = 5$  pages

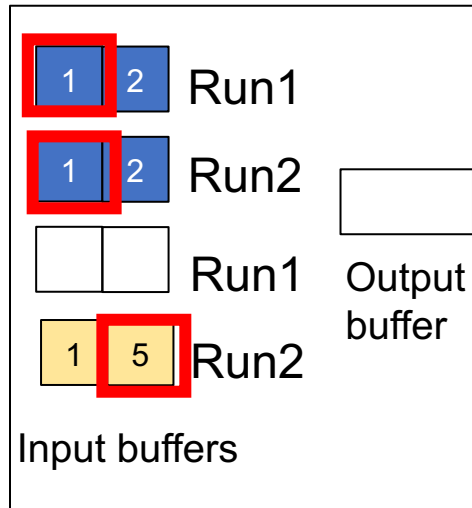

**Step 2:** Join while merging  
Output tuples

- (1,1)
- (1,1)
- (1,1)
- (1,1)

# Merge-Join Example

**Step 2:** Join while merging sorted runs

**Total cost:**  $3B(R) + 3B(S)$

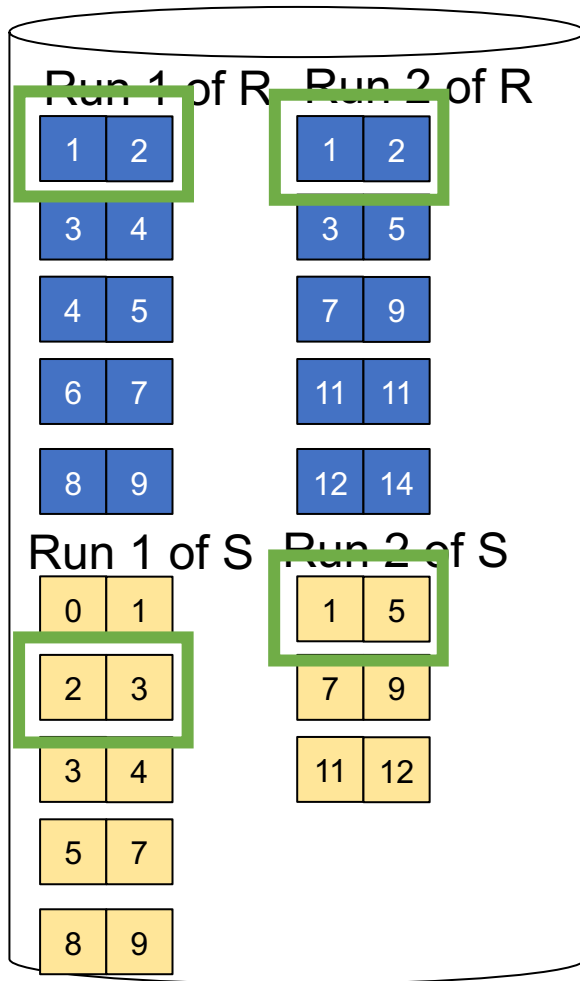

Memory  $M = 5$  pages

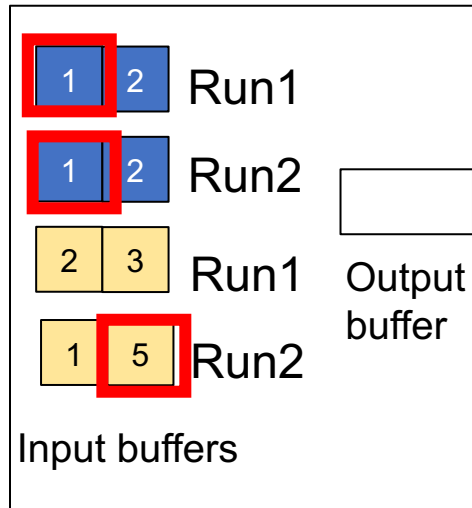

**Step 2:** Join while merging  
Output tuples

- (1,1)
- (1,1)
- (1,1)
- (1,1)

# Merge-Join Example

**Step 2:** Join while merging sorted runs

**Total cost:**  $3B(R) + 3B(S)$

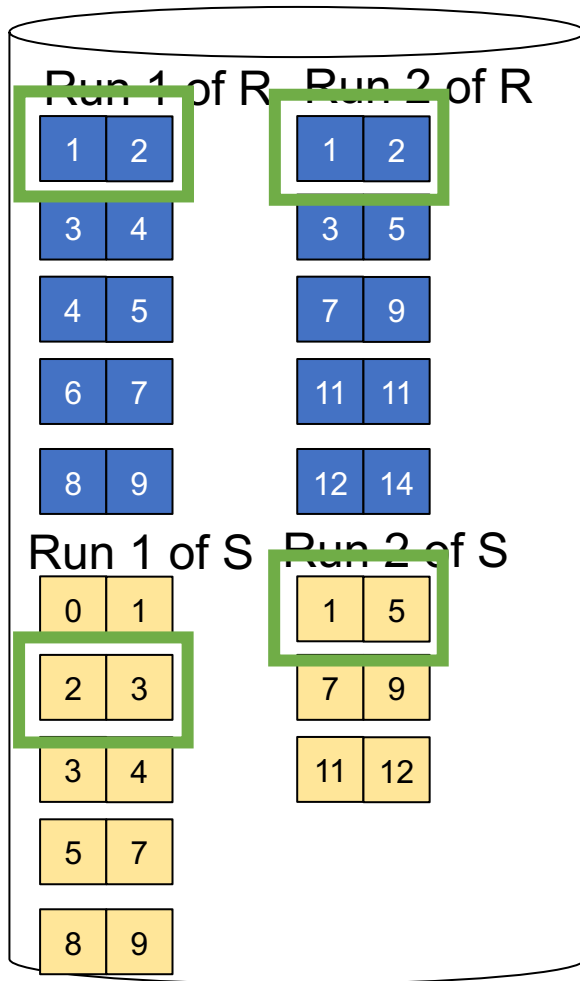

Memory  $M = 5$  pages

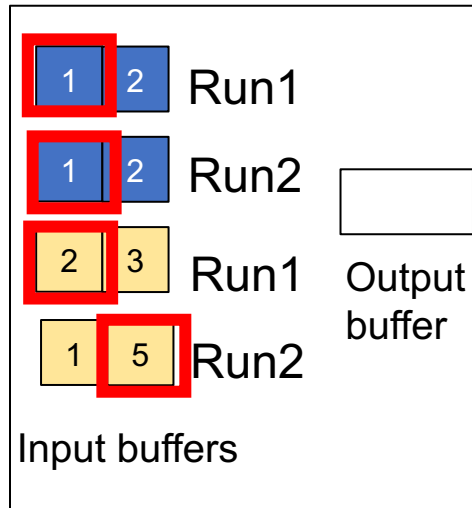

**Step 2:** Join while merging  
Output tuples

- (1,1)
- (1,1)
- (1,1)
- (1,1)

# Merge-Join Example

**Step 2:** Join while merging sorted runs

**Total cost:**  $3B(R) + 3B(S)$

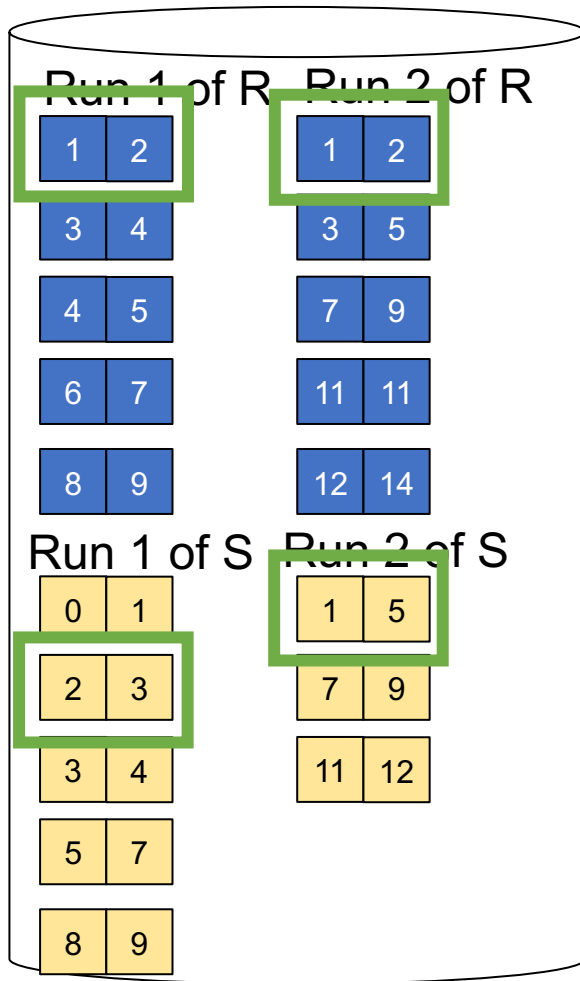

Memory  $M = 5$  pages

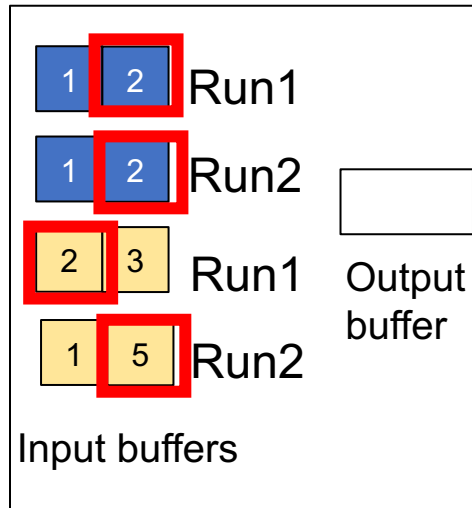

**Step 2:** Join while merging  
Output tuples

- (1,1)
- (1,1)
- (1,1)
- (1,1)
- (2,2)
- (2,2)

# Merge-Join Example

**Step 2:** Join while merging sorted runs

**Total cost:**  $3B(R) + 3B(S)$

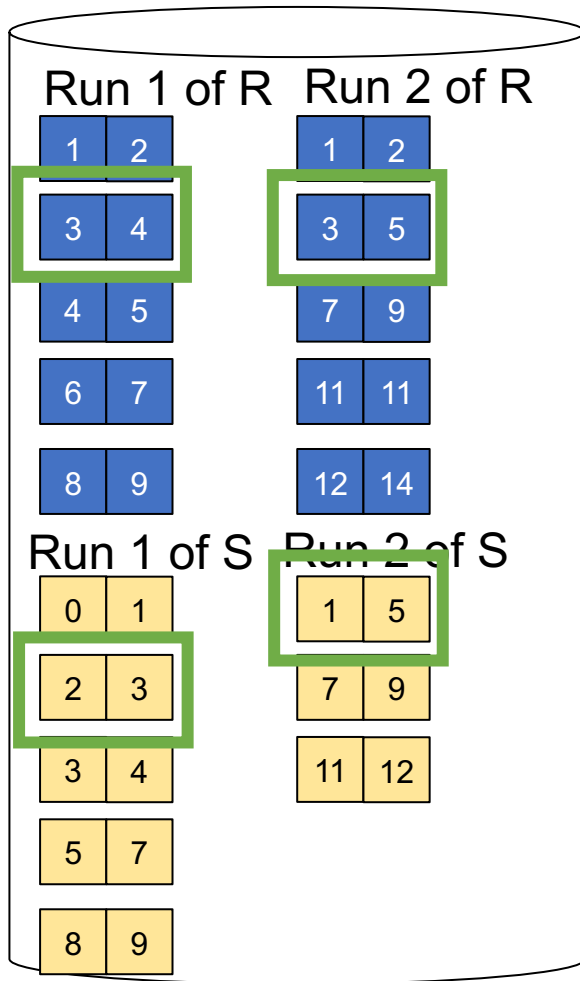

Memory  $M = 5$  pages

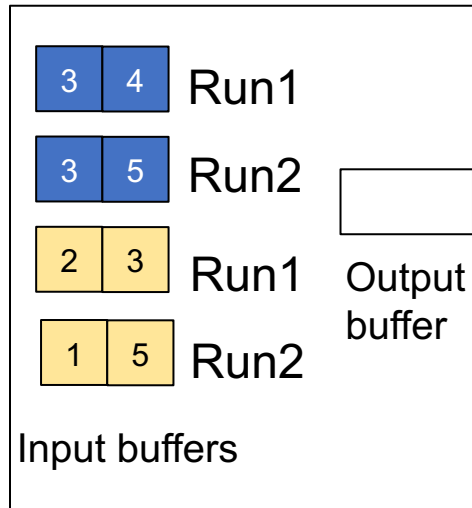

**Step 2:** Join while merging  
Output tuples

- (1,1)
- (1,1)
- (1,1)
- (1,1)
- (2,2)
- (2,2)
- (3,3)
- (3,3)
- ...

# Merge-Join

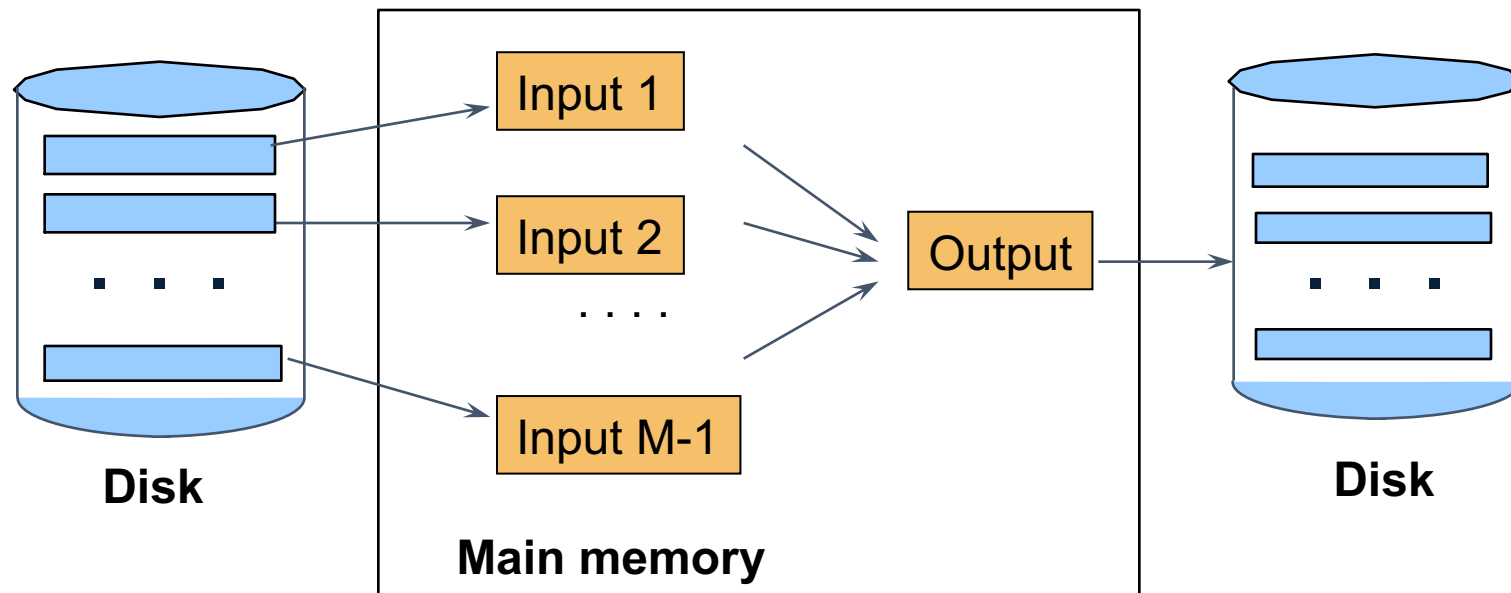

$M_1 = B(R)/M$  runs for  $R$

$M_2 = B(S)/M$  runs for  $S$

Merge-join  $M_1 + M_2$  runs;

need  $M_1 + M_2 \leq M$  to process all runs

i.e.  $B(R) + B(S) \leq M^2$

# Summary of External Join Algorithms

- Block Nested Loop:  $B(S) + B(R) \cdot B(S) / (M-1)$
- Index Join:
  - Clustered:  $B(R) + T(R)B(S)/V(S,a)$
  - Unclustered:  $B(R) + T(R)T(S)/V(S,a)$
- Merge Join:  $3B(R) + 3B(S)$ 
  - $B(R) + B(S) \leq M^2$
- Partitioned Hash Join: (coming up next)

# Partitioned Hash Algorithms

- Partition  $R$  it into  $k$  buckets on disk:  
 $R_1, R_2, R_3, \dots, R_k$

# Partitioned Hash Algorithms

- Partition  $R$  it into  $k$  buckets on disk:  
 $R_1, R_2, R_3, \dots, R_k$
- Assuming  $B(R_1)=B(R_2)=\dots=B(R_k)$ , we have  
 $B(R_i) = B(R)/k$ , for all  $i$

# Partitioned Hash Algorithms

- Partition  $R$  it into  $k$  buckets on disk:  
 $R_1, R_2, R_3, \dots, R_k$
- Assuming  $B(R_1)=B(R_2)=\dots=B(R_k)$ , we have  
 $B(R_i) = B(R)/k$ , for all  $i$
- Goal: each  $R_i$  should fit in main memory:  
 $B(R_i) \leq M$

# Partitioned Hash Algorithms

- Partition  $R$  it into  $k$  buckets on disk:  
 $R_1, R_2, R_3, \dots, R_k$
- Assuming  $B(R_1)=B(R_2)=\dots=B(R_k)$ , we have  
 $B(R_i) = B(R)/k$ , for all  $i$
- Goal: each  $R_i$  should fit in main memory:  
 $B(R_i) \leq M$

How do we choose  $k$ ?

# Partitioned Hash Algorithms

- We choose  $k = M-1$  Each bucket has size approx.  $B(R)/(M-1) \approx B(R)/M$

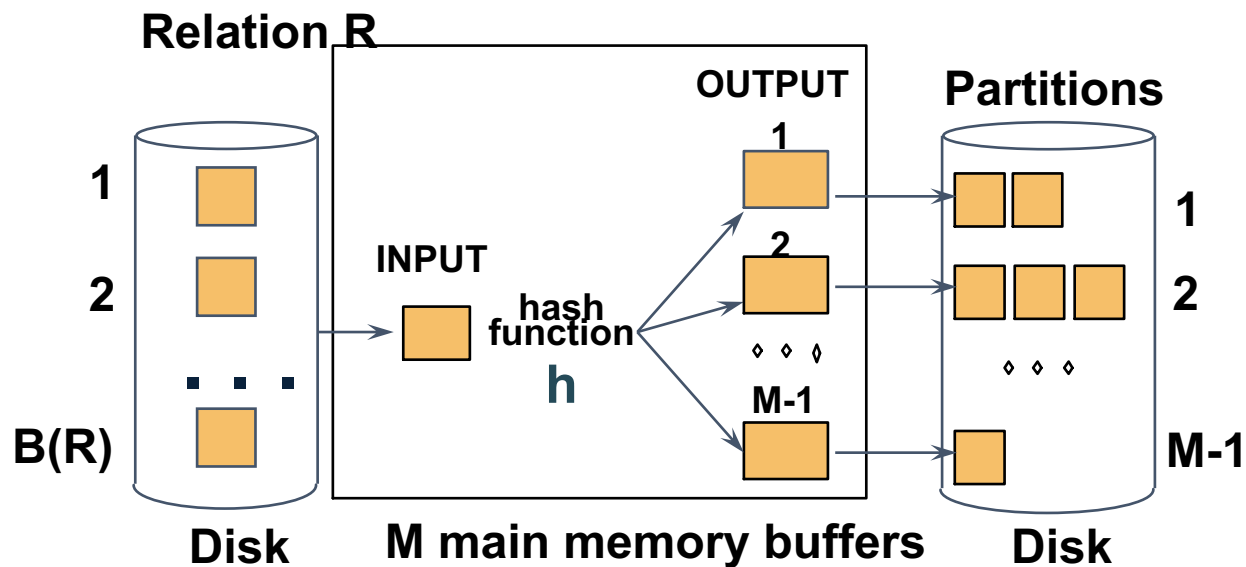

Assumption:  $B(R)/M \leq M$ , i.e.  $B(R) \leq M^2$

# Partitioned Hash Join (Grace-Join)

$R \bowtie S$

- Step 1:
  - Hash S into M-1 buckets
  - Send all buckets to disk
- Step 2
  - Hash R into M-1 buckets
  - Send all buckets to disk
- Step 3
  - Join every pair of buckets

Note: partitioned hash-join  
is sometimes called  
grace-join

# Partitioned Hash-Join Example

**Step 1:** Read relation S one page at a time and hash into  $M-1$  (=4 buckets)

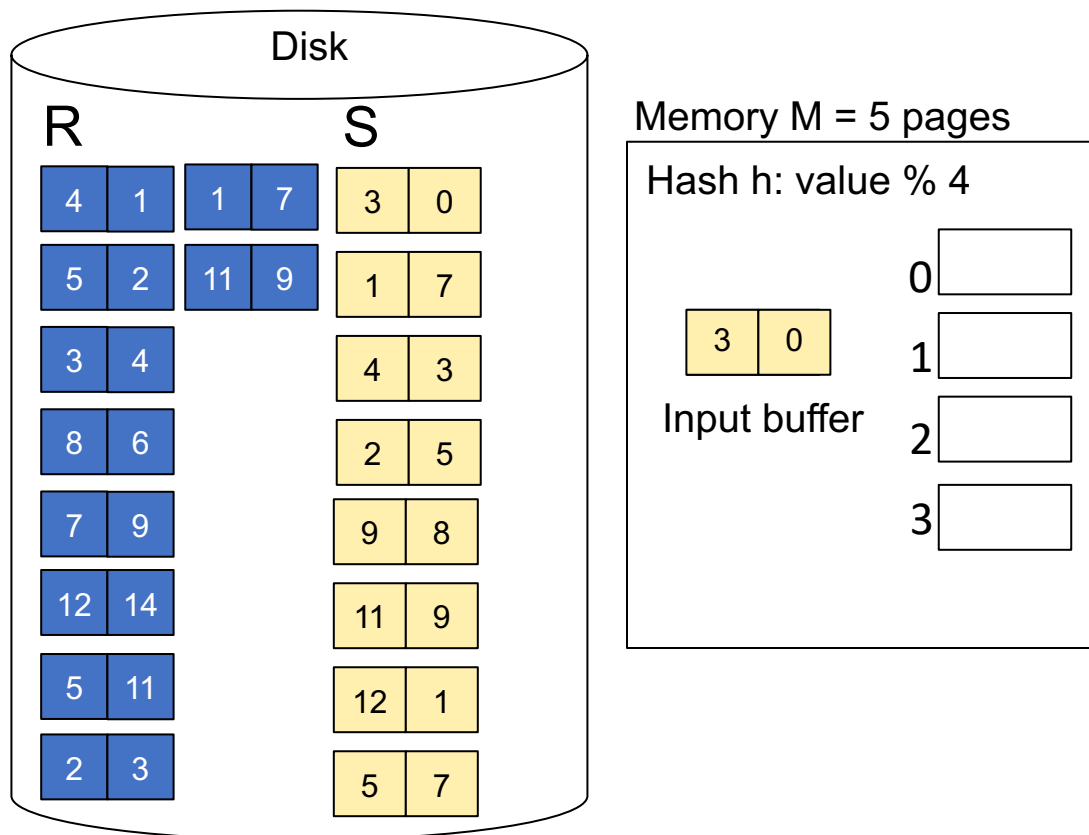

# Partitioned Hash-Join Example

**Step 1:** Read relation S one page at a time and hash into the 4 buckets

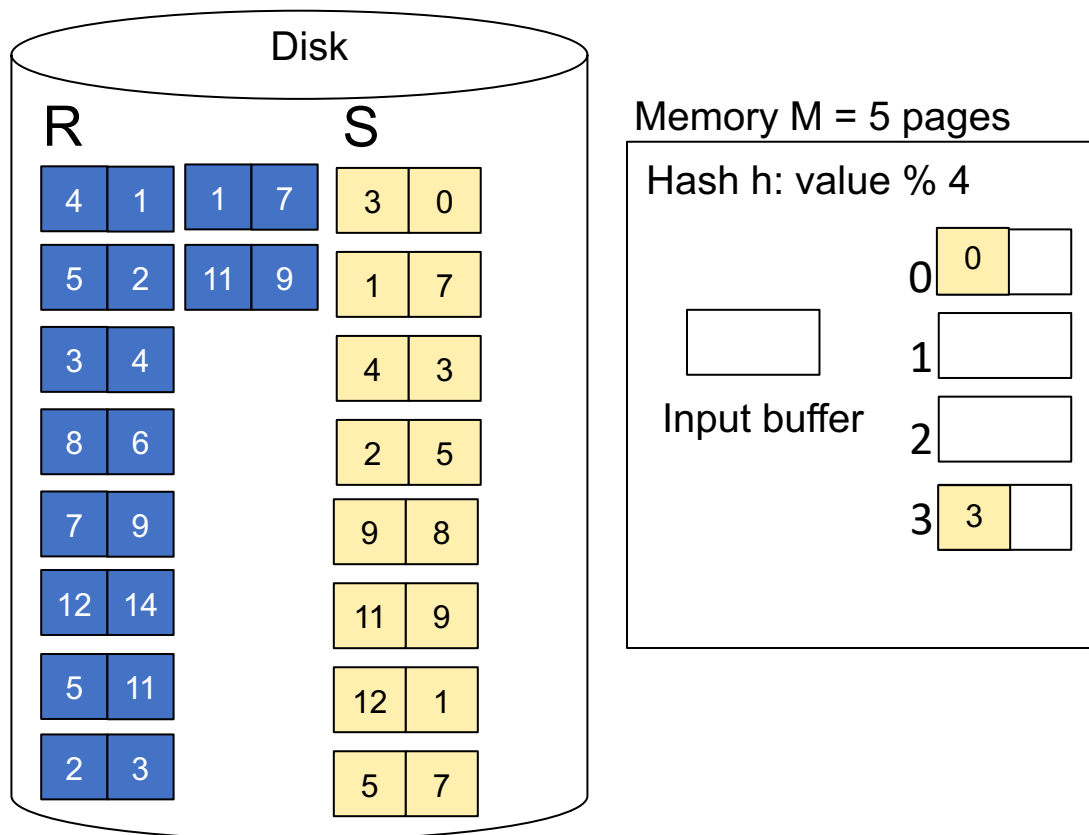

# Partitioned Hash-Join Example

**Step 1:** Read relation S one page at a time and hash into the 4 buckets

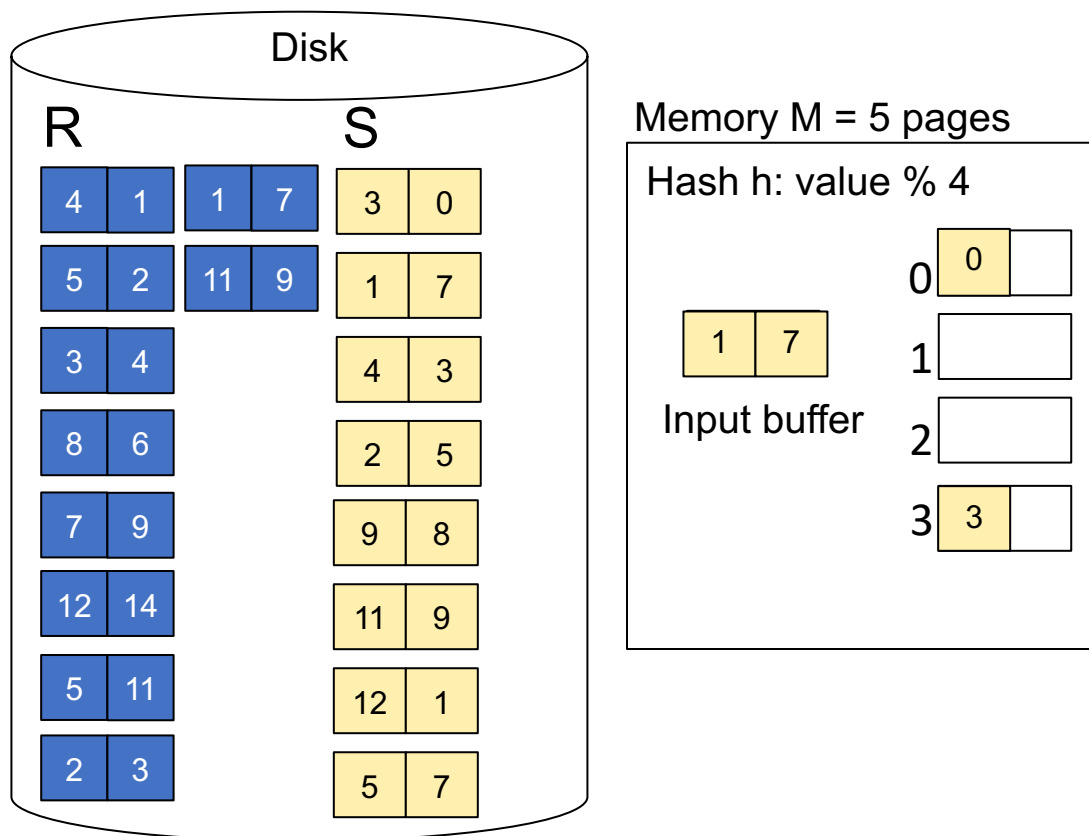

# Partitioned Hash-Join Example

**Step 1:** Read relation S one page at a time and hash into the 4 buckets

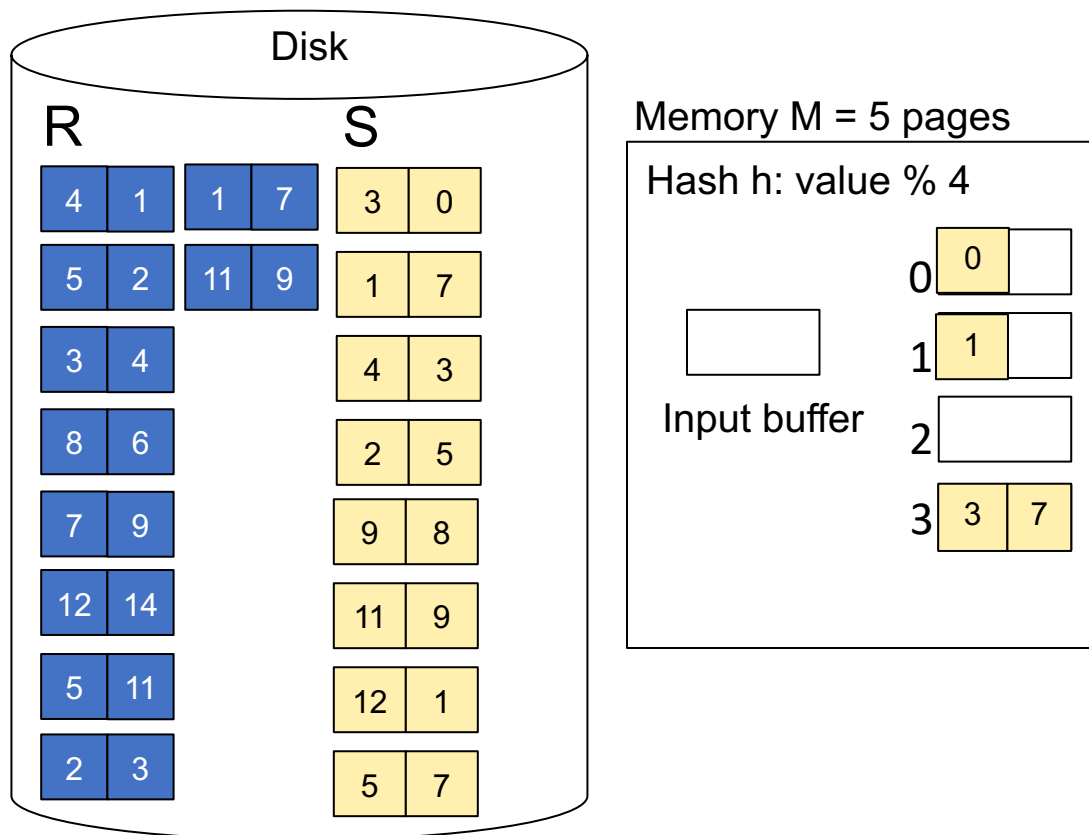

# Partitioned Hash-Join Example

**Step 1:** Read relation S one page at a time and hash into the 4 buckets

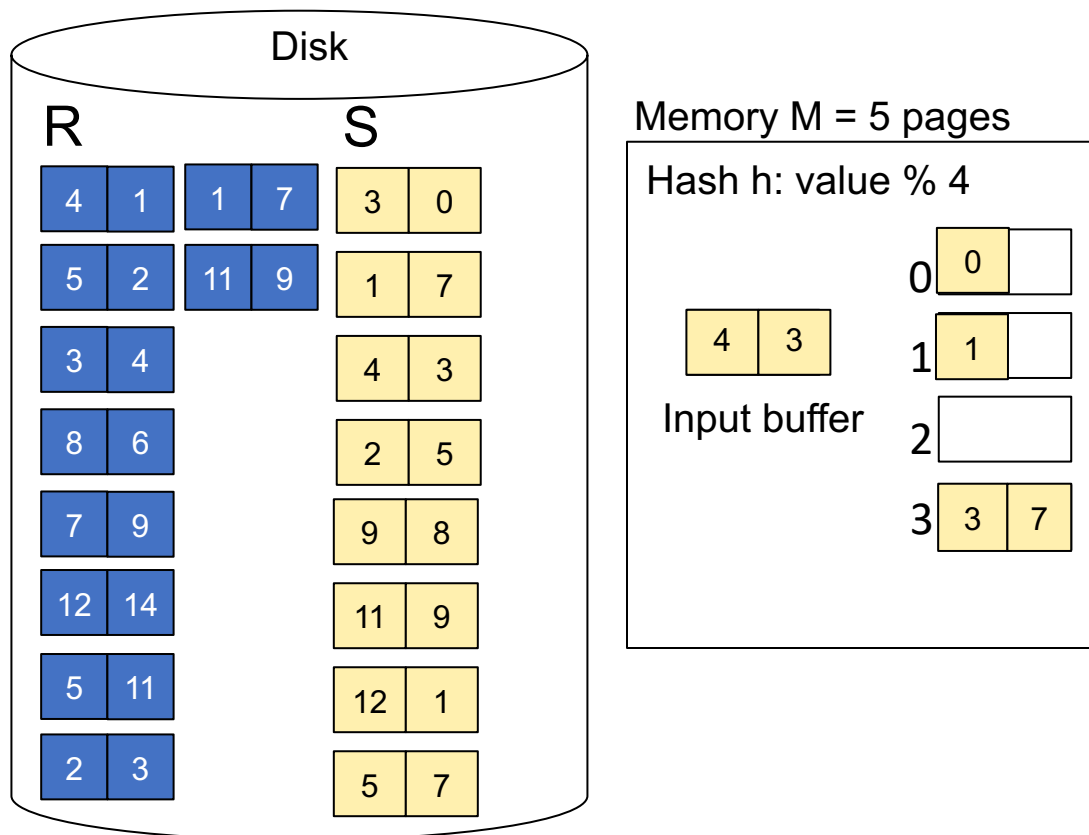

# Partitioned Hash-Join Example

**Step 1:** Read relation S one page at a time and hash into the 4 buckets  
When a bucket fills up, flush it to disk

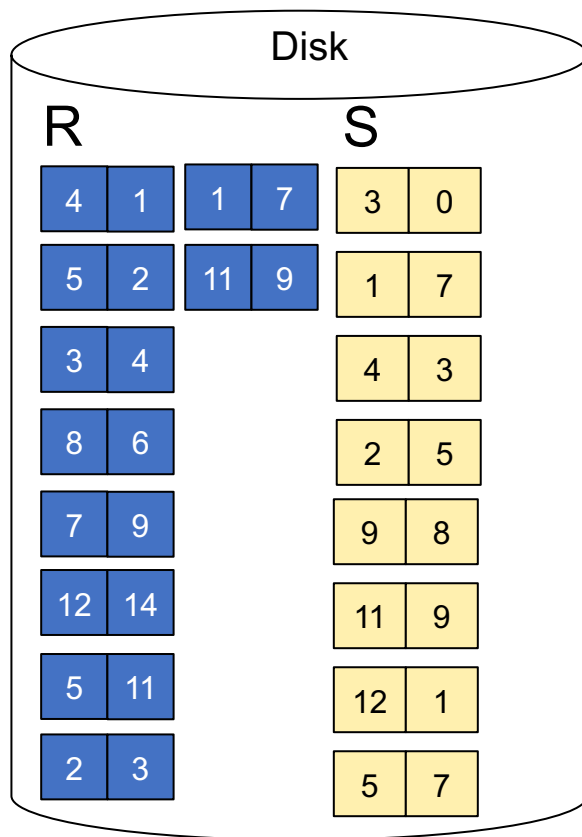

Memory M = 5 pages

Hash h: value % 4

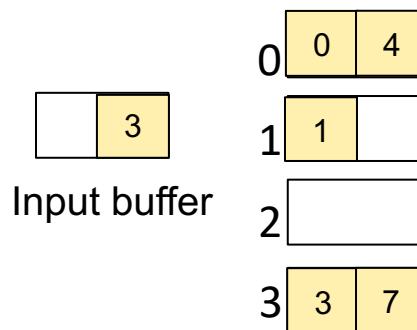

# Partitioned Hash-Join Example

**Step 1:** Read relation S one page at a time and hash into the 4 buckets  
When a bucket fills up, flush it to disk

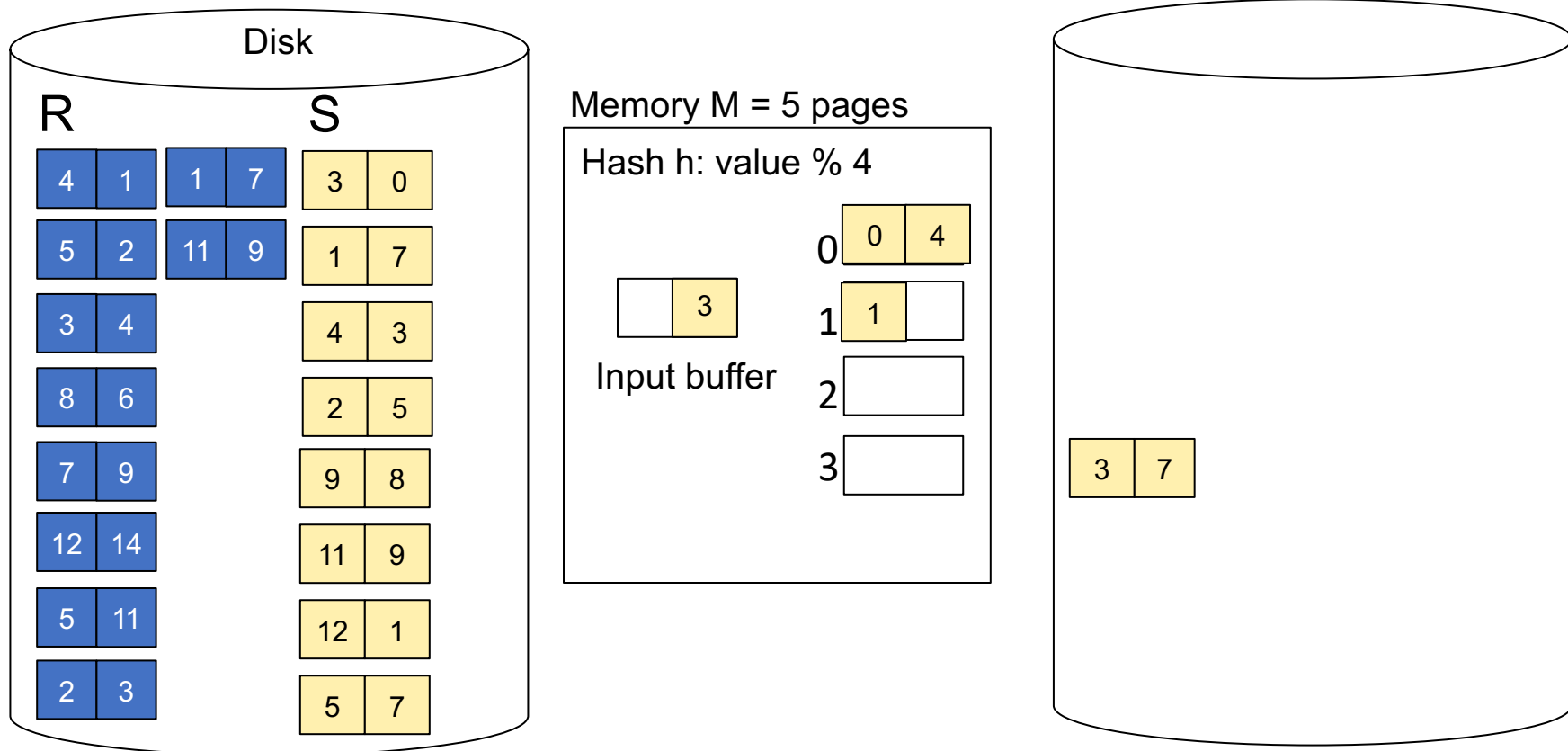

# Partitioned Hash-Join Example

**Step 1:** Read relation S one page at a time and hash into the 4 buckets  
When a bucket fills up, flush it to disk

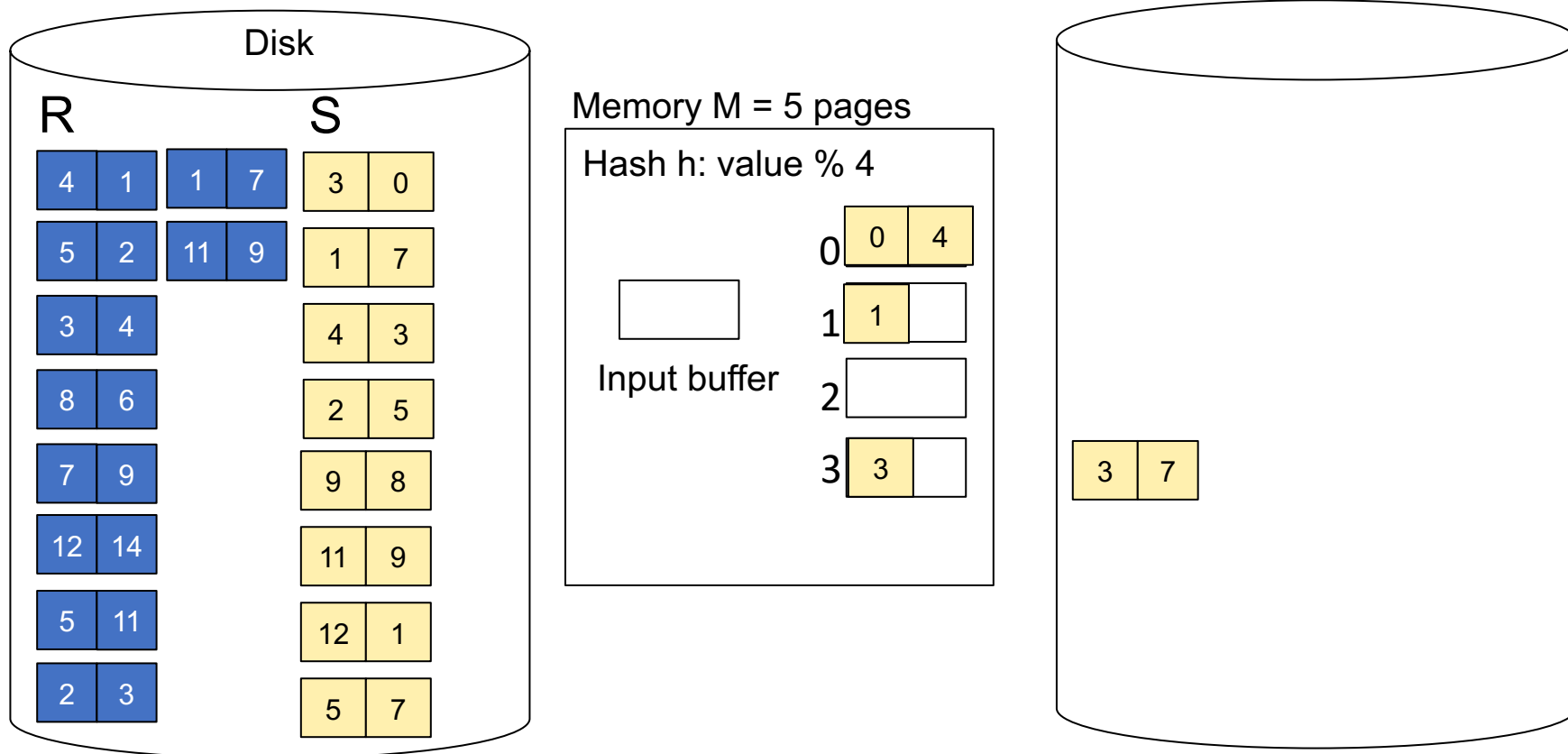

# Partitioned Hash-Join Example

**Step 1:** Read relation S one page at a time and hash into the 4 buckets  
 At the end, we get relation S back on disk split into 4 buckets

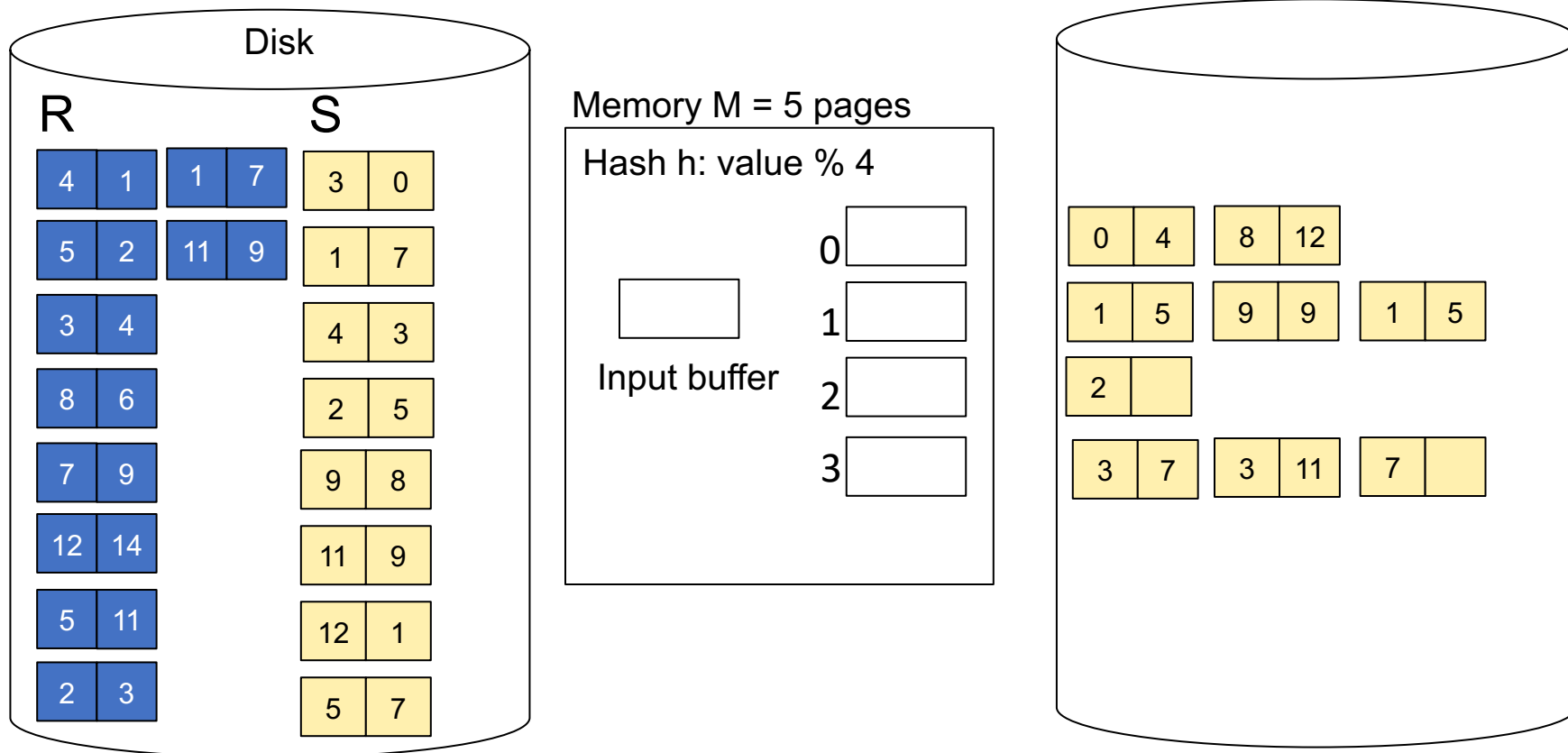

# Partitioned Hash-Join Example

**Step 2:** Read relation R one page at a time and hash into same 4 buckets

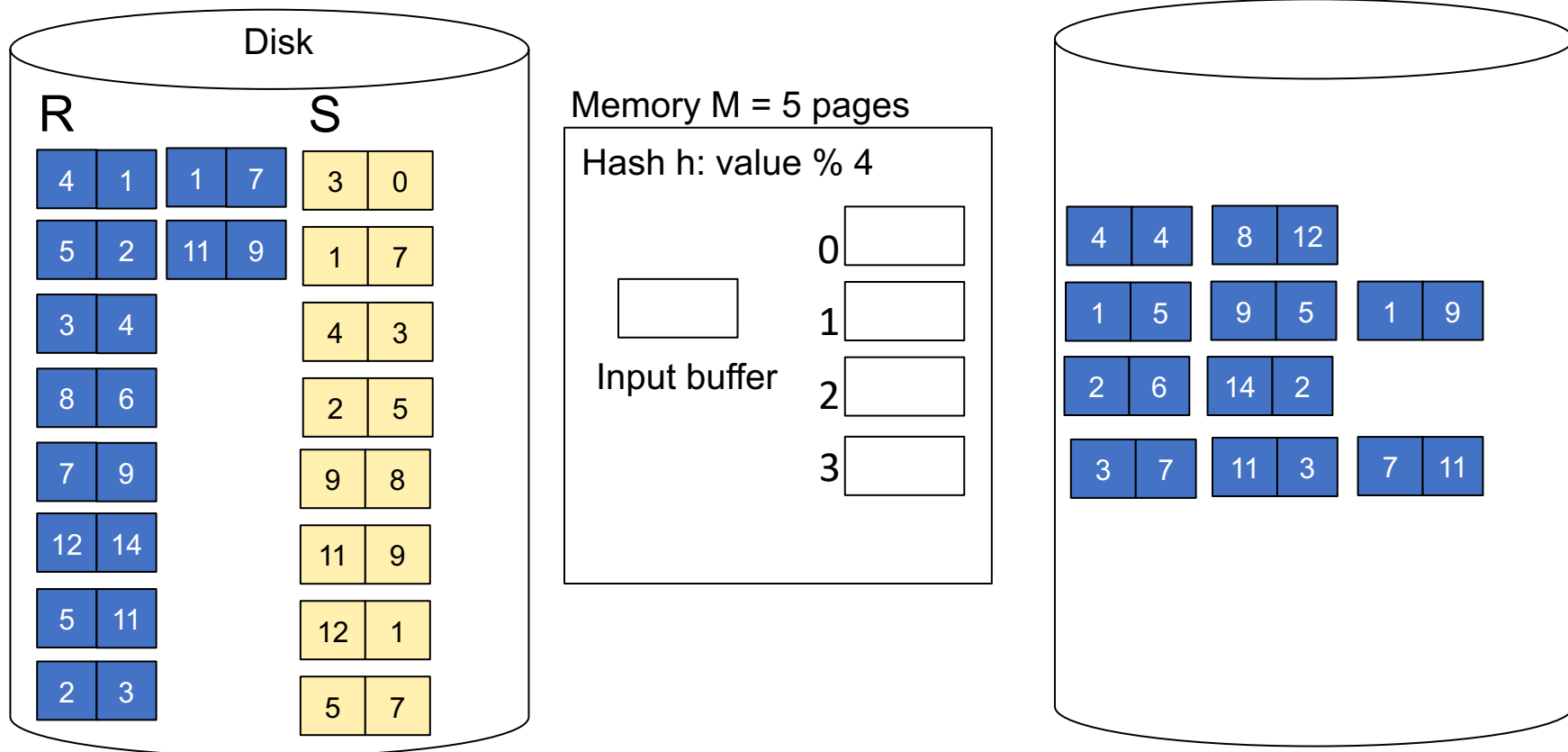

# Partitioned Hash-Join Example

**Step 3:** Read one partition of R and create hash table in memory using a *different* hash function

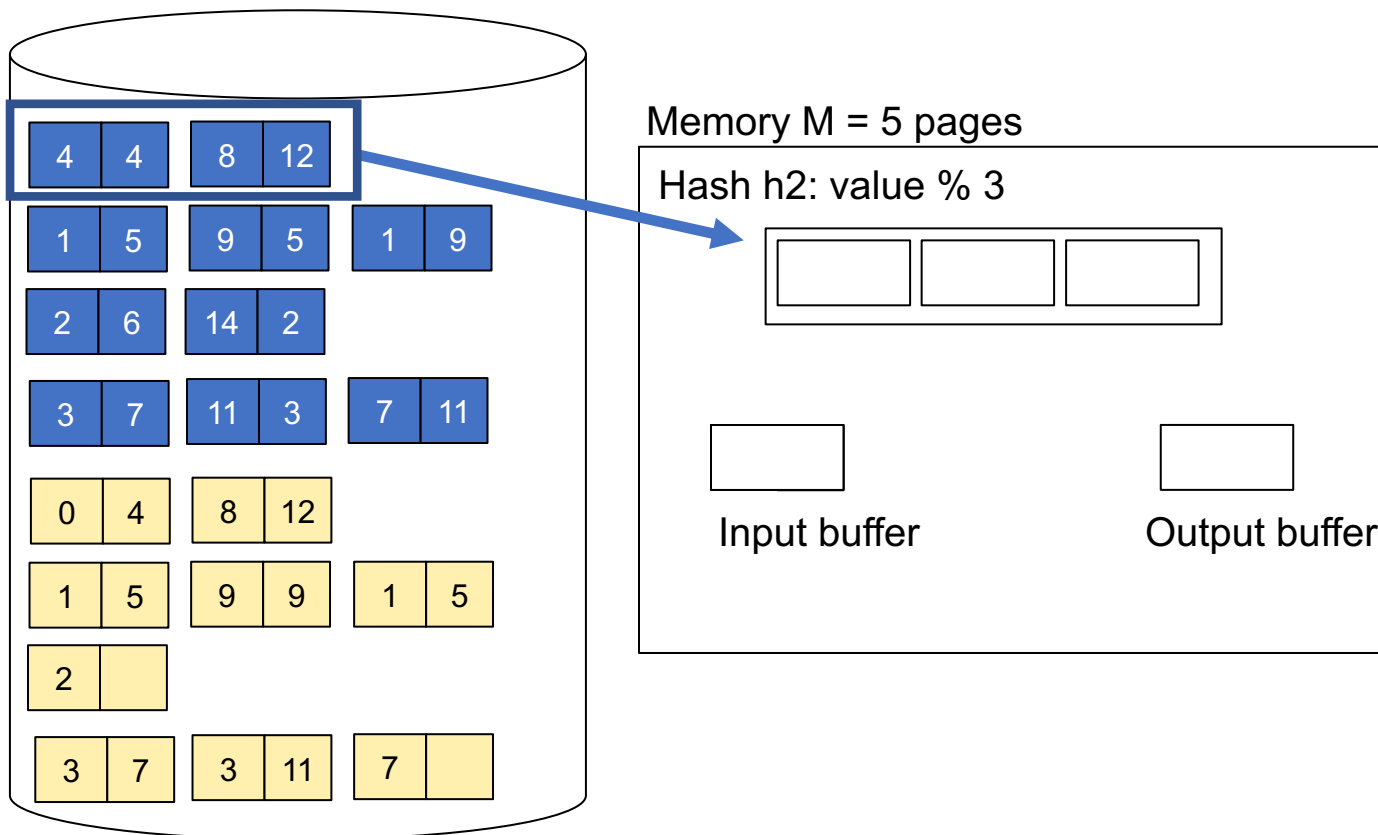

# Partitioned Hash-Join Example

**Step 3:** Read one partition of R and create hash table in memory using a *different* hash function

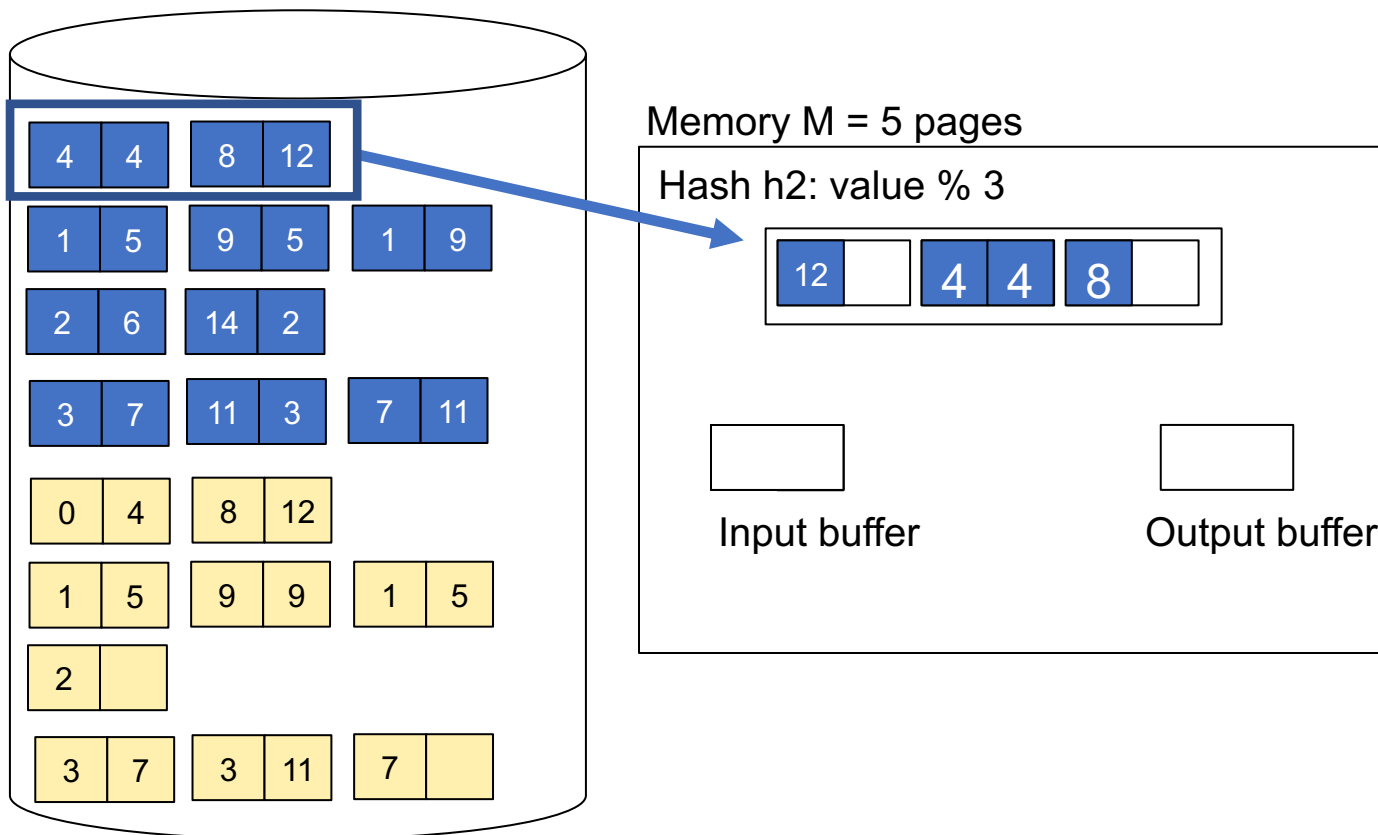

# Partitioned Hash-Join Example

**Step 3:** Read one partition of R and create hash table in memory using a *different* hash function

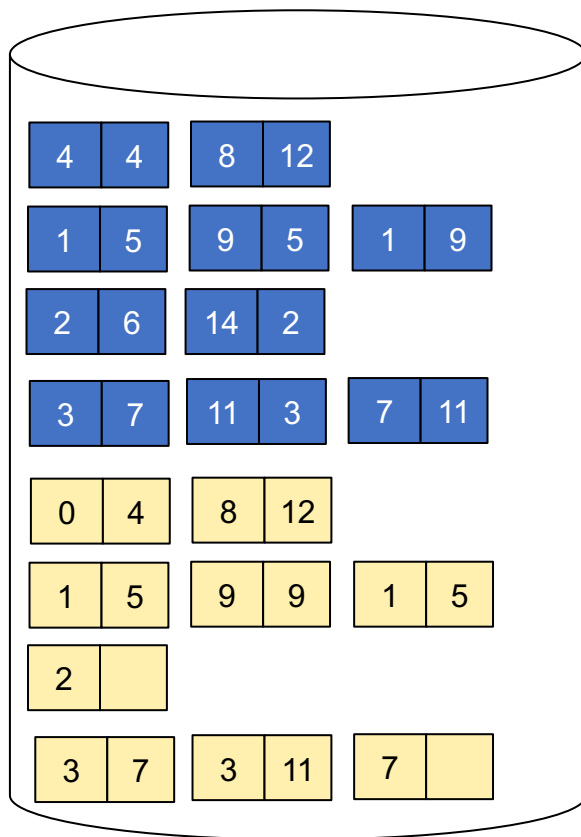

Memory M = 5 pages

Hash h2: value % 3

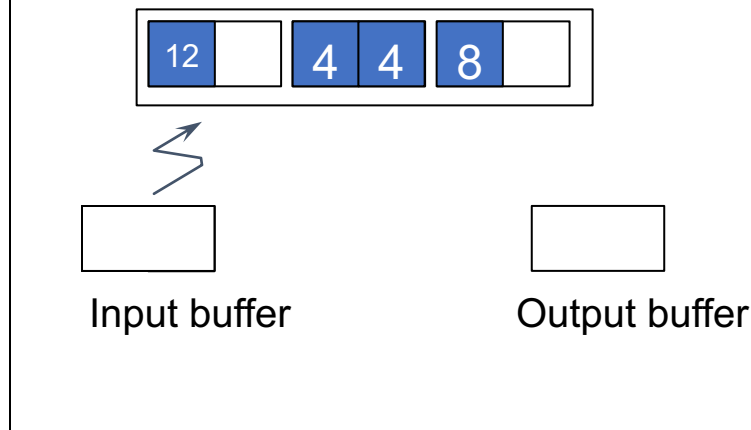

# Partitioned Hash-Join Example

**Step 4:** Scan matching partition of S and probe the hash table

**Step 5:** Repeat for all the buckets

**Total cost:**  $3B(R) + 3B(S)$

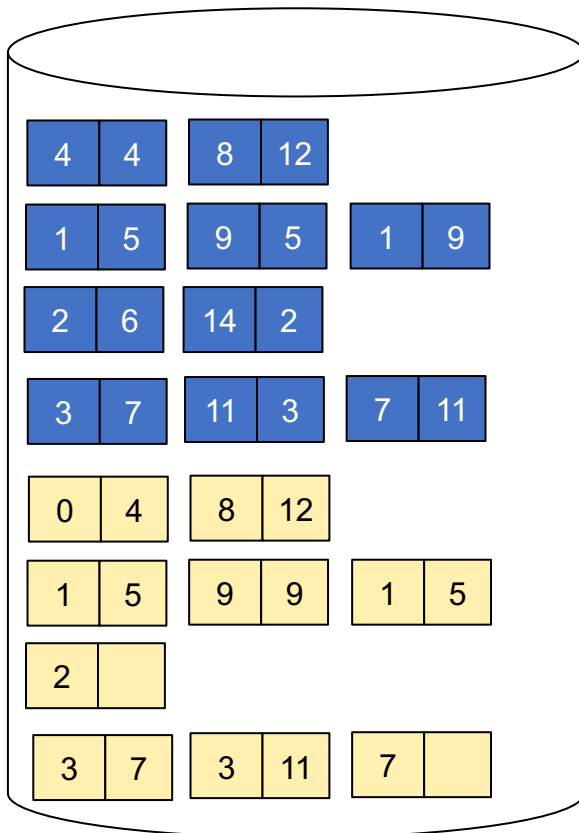

Memory M = 5 pages

Hash h2: value % 3

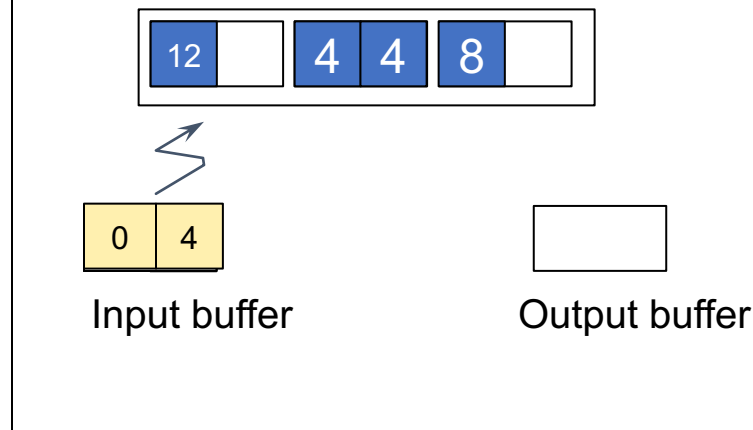

# Partitioned Hash-Join Example

**Step 4:** Scan matching partition of S and probe the hash table

**Step 5:** Repeat for all the buckets

**Total cost:**  $3B(R) + 3B(S)$

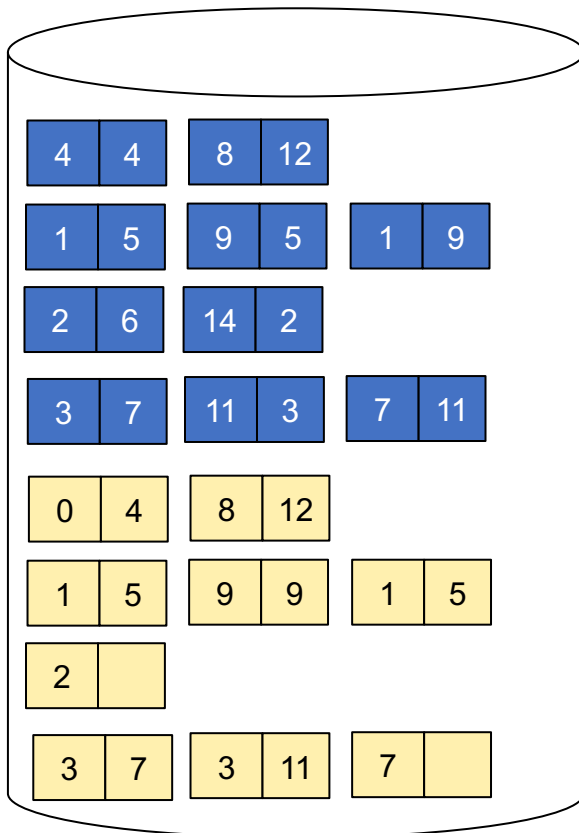

Memory M = 5 pages

Hash h2: value % 3

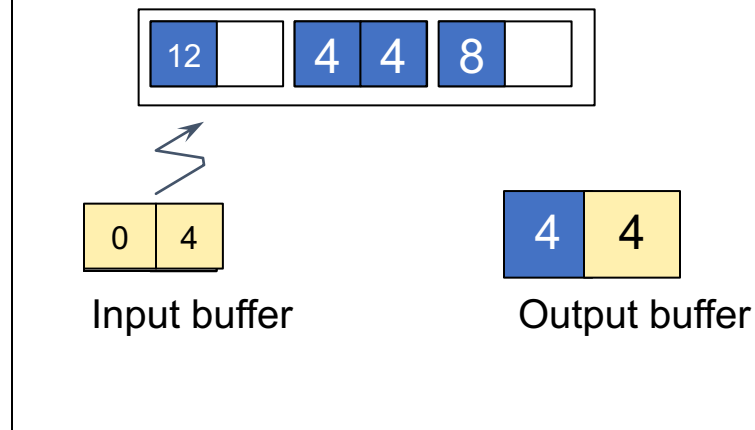

# Partitioned Hash-Join

- Partition both relations using hash fn  $h$ :  $R$  tuples in partition  $i$  will only match  $S$  tuples in partition  $i$ .

Original Relation

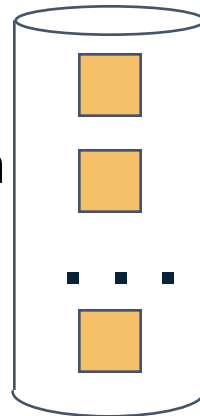

Disk

INPUT



hash  
function  
 $h$

OUTPUT



B main memory buffers

Partitions

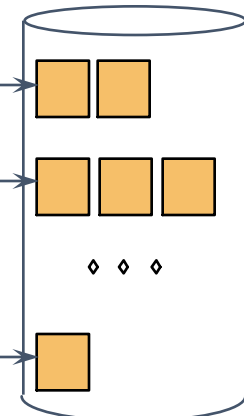

1  
2  
...  
M-1

Disk

# Partitioned Hash-Join

- Partition both relations using hash fn  $h$ :  $R$  tuples in partition  $i$  will only match  $S$  tuples in partition  $i$ .

Original Relation

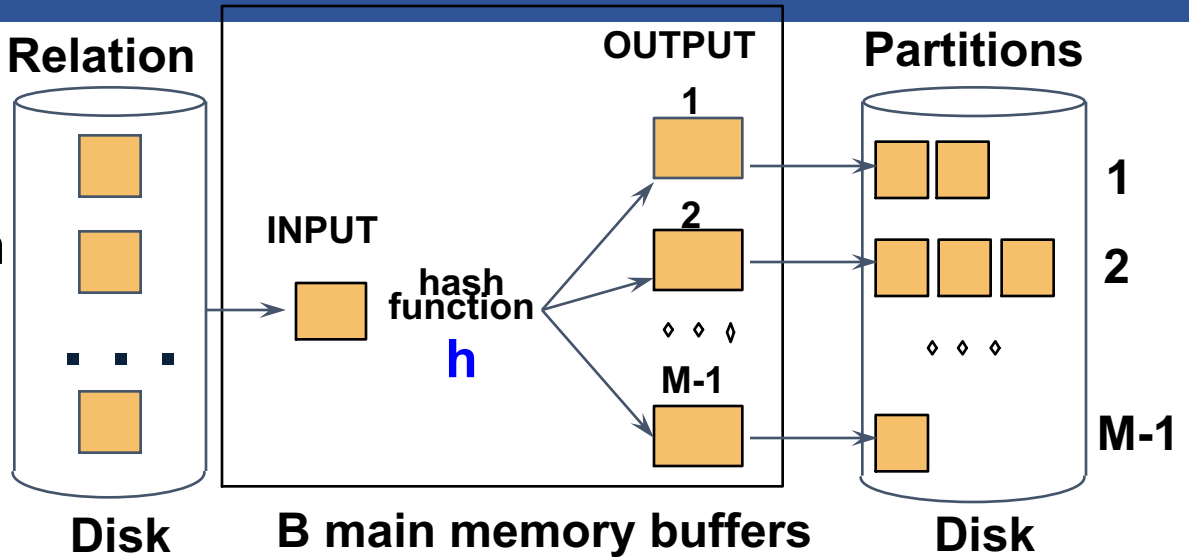

- Read in a partition of  $R$ , hash it using  $h_2$  ( $\neq h$ ). Scan matching partition of  $S$ , search for matches.

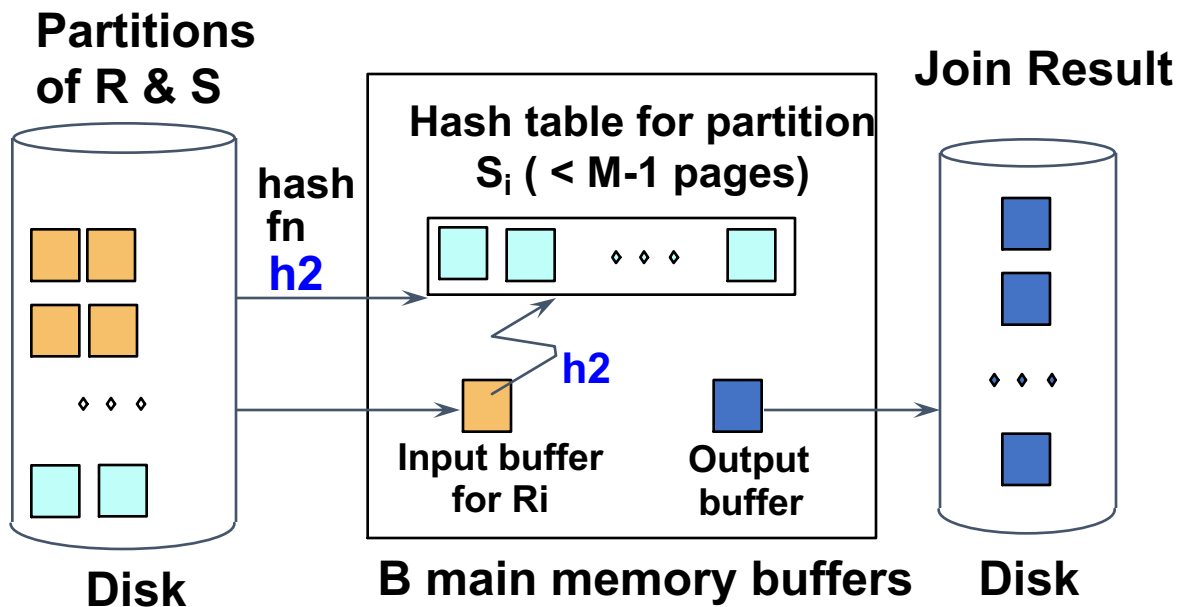

# Partitioned Hash-Join

- Cost:  $3B(R) + 3B(S)$
- Assumption:  $\min(B(R), B(S)) \leq M^2$

# Hybrid Hash Join Algorithm (see book)

- Partition  $S$  into  $k$  buckets
  - $t$  buckets  $S_1, \dots, S_t$  stay in memory
  - $k-t$  buckets  $S_{t+1}, \dots, S_k$  to disk
- Partition  $R$  into  $k$  buckets
  - First  $t$  buckets join immediately with  $S$
  - Rest  $k-t$  buckets go to disk
- Finally, join  $k-t$  pairs of buckets:  
 $(R_{t+1}, S_{t+1}), (R_{t+2}, S_{t+2}), \dots, (R_k, S_k)$

# Summary of External Join Algorithms

- Block Nested Loop:  $B(S) + B(R) \cdot B(S) / (M-1)$
- Index Join:
  - Clustered:  $B(R) + T(R)B(S)/V(S,a)$
  - Unclustered:  $B(R) + T(R)T(S)/V(S,a)$
- Merge Join:  $3B(R)+3B(S)$ 
  - $B(R)+B(S) \leq M^2$
- Partitioned Hash Join:  $3B(R)+3B(S)$ 
  - $\min(B(R), B(S)) \leq M^2$