

Database System Internals

Operator Algorithms (part 2)

Paul G. Allen School of Computer Science and Engineering
University of Washington, Seattle

Today's Outline

Query Execution Algorithms:

- Catch-up from last lecture
- Finish operator implementation

Operator Algorithms

Design criteria

- Cost: IO, CPU, Network
- Memory utilization
- Load balance (for parallel operators)

Cost Parameters

- **Cost = total number of I/Os**
 - This is a simplification that ignores CPU, network
- **Parameters:**
 - **$B(R)$** = # of blocks (i.e., pages) for relation R
 - **$T(R)$** = # of tuples in relation R
 - **$V(R, a)$** = # of distinct values of attribute a
 - When a is a key, **$V(R, a) = T(R)$**
 - When a is not a key, **$V(R, a)$** can be anything $< T(R)$

Convention

- Cost = the cost of **reading** operands from disk, plus cost to **read/write** intermediate results
- Cost of **writing** the final result to disk is *not included*; need to count it separately when applicable

Outline

- **Join operator algorithms**
 - One-pass algorithms (Sec. 15.2 and 15.3)
 - Index-based algorithms (Sec 15.6)
 - Two-pass algorithms (Sec 15.4 and 15.5)
- **Note about readings:**
 - In class, we discuss only algorithms for joins
 - Other operators are easier: book has extra details

Join Algorithms

- Hash join
- Nested loop join
- Sort-merge join

Hash Join

Hash join: $R \bowtie S$

- Scan R , build buckets in main memory
- Then scan S and join
- Cost: $B(R) + B(S)$

- One-pass algorithm when $B(R) \leq M$

Note: the inner relation is the relation on which we build the hash table

- Usually this is the right relation of $R \bowtie S$, i.e. S .
- But the following slides choose the left relation, i.e. R

Hash Join Example

Patient(pid, name, address)

Insurance(pid, provider, policy_nb)

Patient ⋈ Insurance

Patient

1	'Bob'	'Seattle'
2	'Ela'	'Everett'

3	'Jill'	'Kent'
4	'Joe'	'Seattle'

Insurance

2	'Blue'	123
4	'Prem'	432

4	'Prem'	343
1	'GrpH'	554

Two tuples
per page

Hash Join Example

Patient \bowtie Insurance

Some large-enough nb

Memory M = 21 pages

Showing pid only

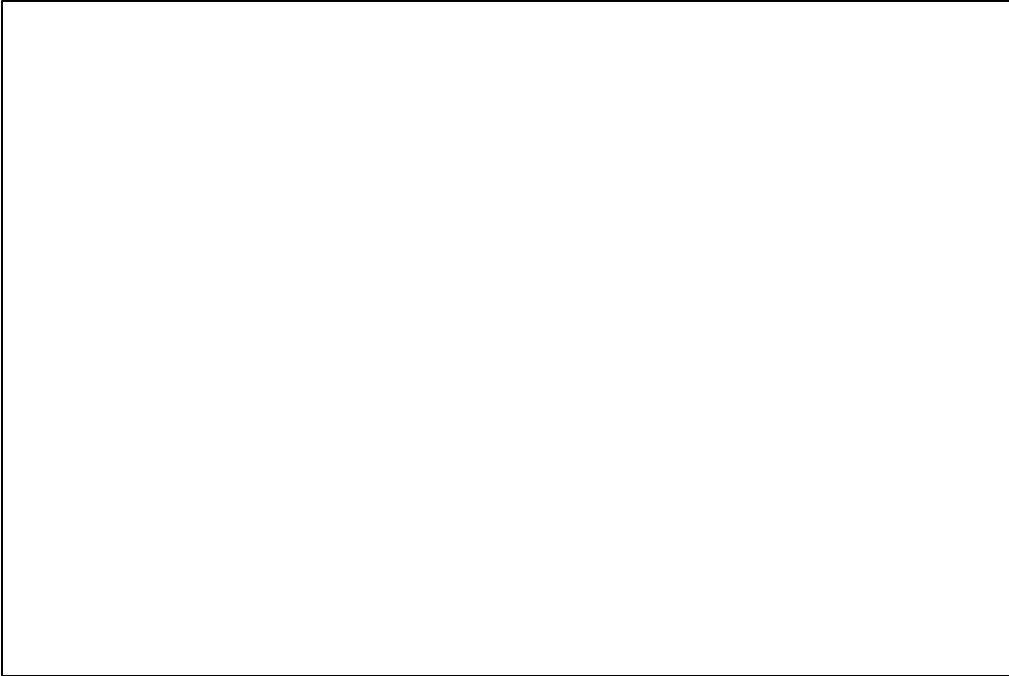
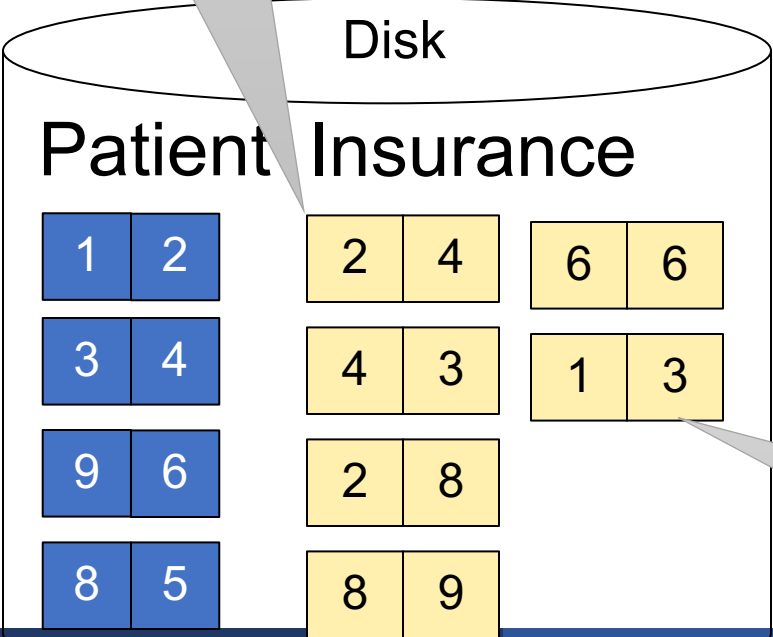

This is one page with two tuples

Hash Join Example

Step 1: Scan Patient and **build** hash table in memory
Can be done in method open()

Memory M = 21 pages

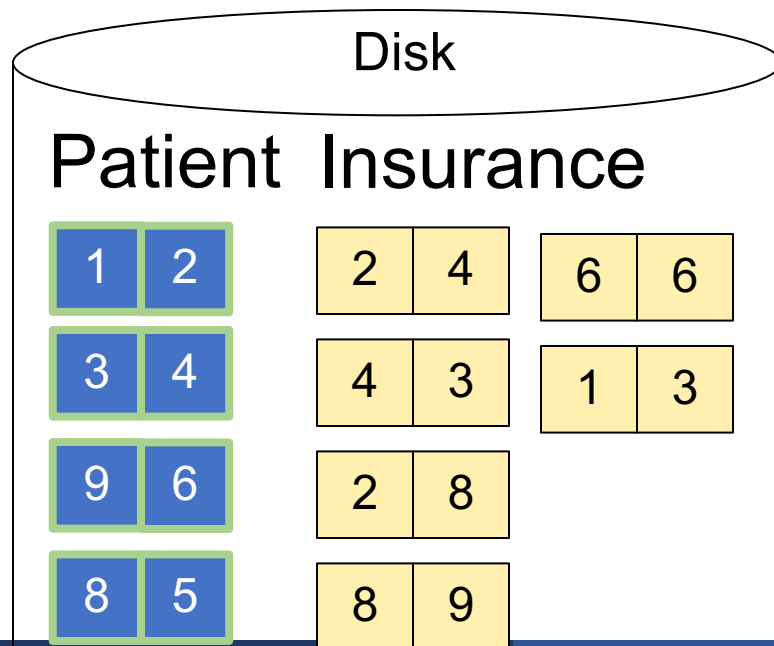
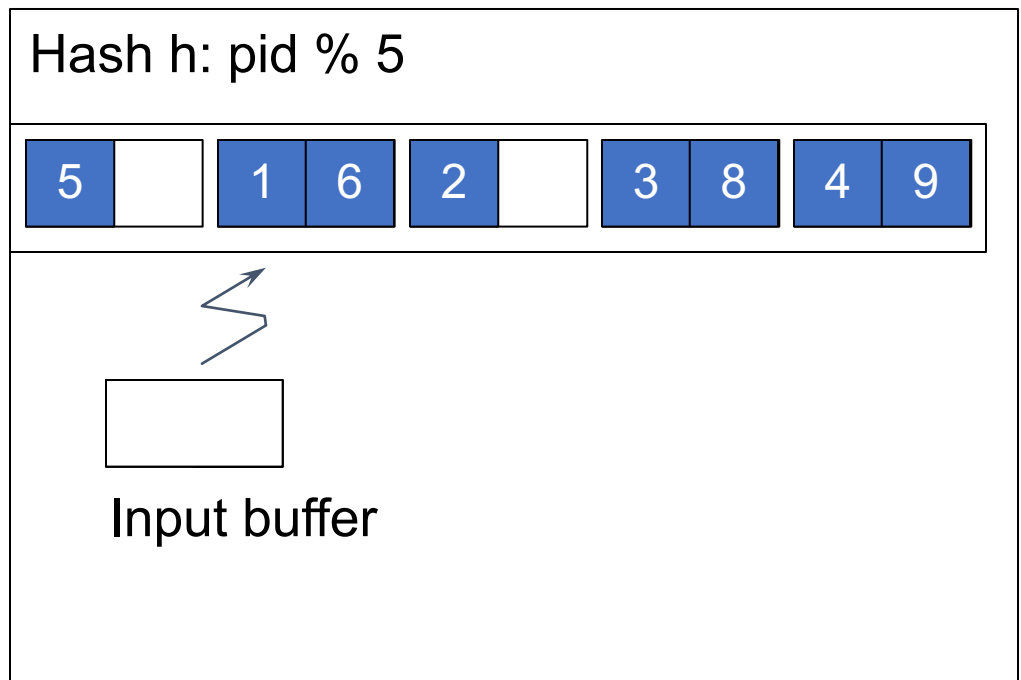

Hash Join Example

Step 2: Scan Insurance and **probe** into hash table
Done during
calls to next()

Memory M = 21 pages

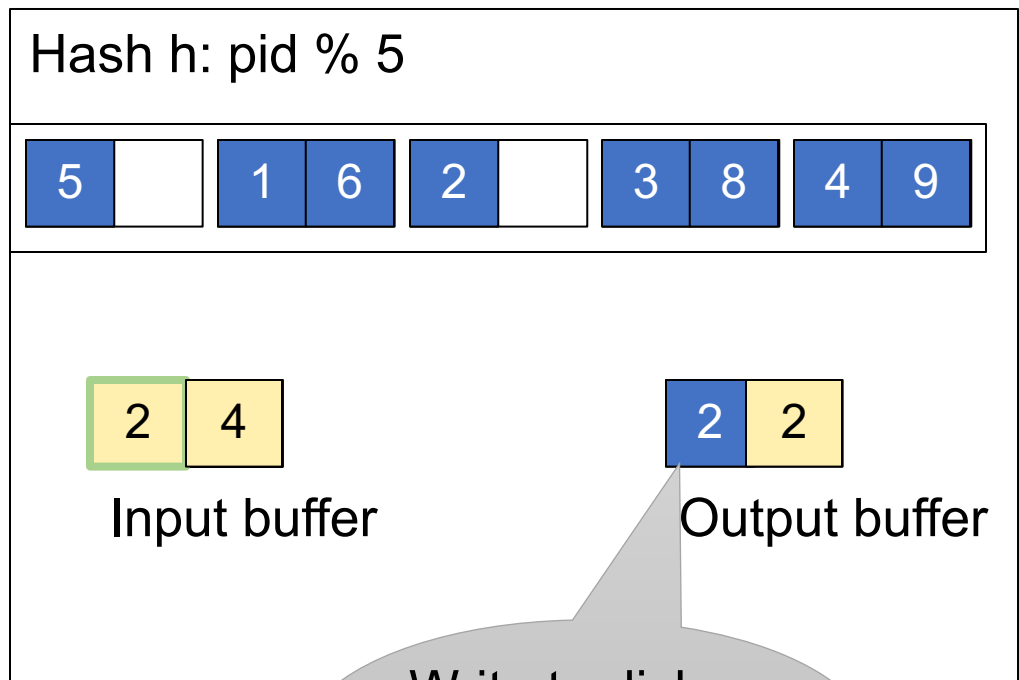

Write to disk or
pass to next
operator

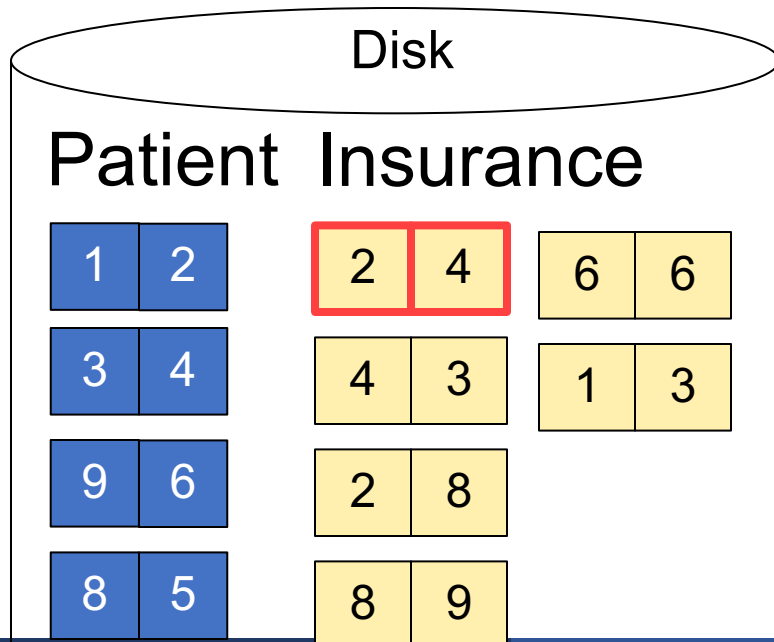

Hash Join Example

Step 2: Scan Insurance and **probe** into hash table
Done during
calls to next()

Memory M = 21 pages

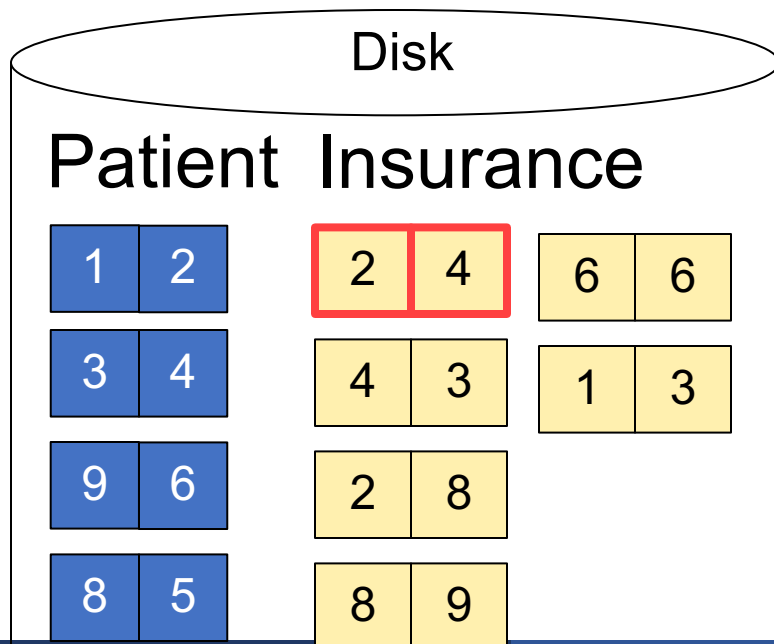
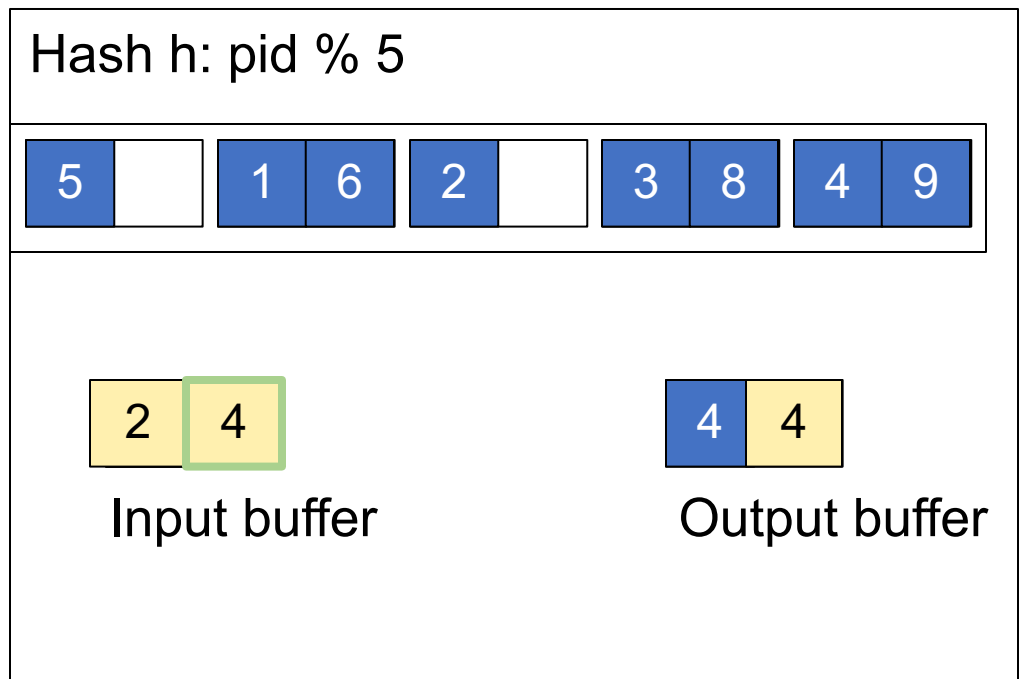

Hash Join Example

Step 2: Scan Insurance and **probe** into hash table
Done during
calls to next()

Memory M = 21 pages

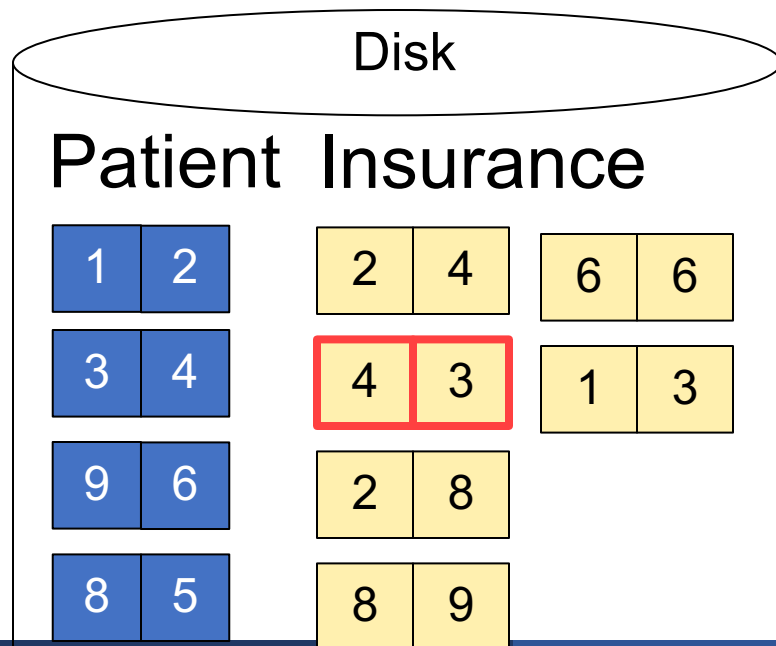
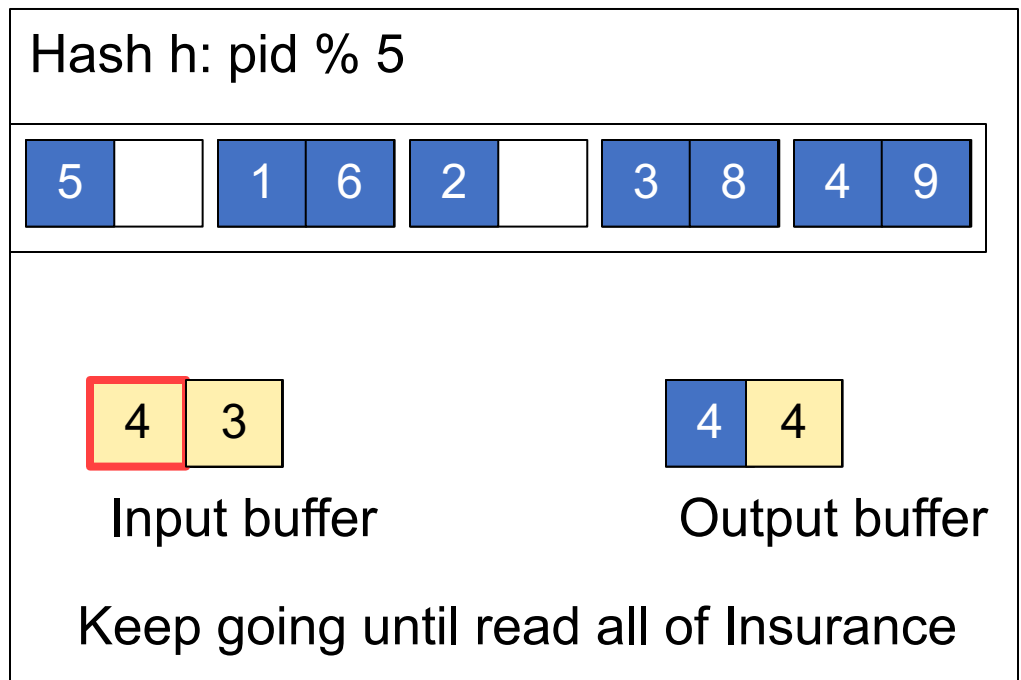

Cost: $B(R) + B(S)$

Discussion

- Hash-join is the workhorse of database systems
- The hash table is built on the heap, not in BP; hence it is not organized in pages, but pages are still convenient to measure its size
- Hash-join works great when:
 - The inner table fits in main memory
 - The hash function is good (never write your own!)
 - The data has no skew (discuss in class...)

Nested Loop Joins

- Tuple-based nested loop $R \bowtie S$
- R is the outer relation, S is the inner relation

```
for each tuple  $t_1$  in  $R$  do  
  for each tuple  $t_2$  in  $S$  do  
    if  $t_1$  and  $t_2$  join then output  $(t_1, t_2)$ 
```

What is the **Cost**?

Nested Loop Joins

- Tuple-based nested loop $R \bowtie S$
- R is the outer relation, S is the inner relation

```
for each tuple  $t_1$  in  $R$  do  
  for each tuple  $t_2$  in  $S$  do  
    if  $t_1$  and  $t_2$  join then output  $(t_1, t_2)$ 
```

- **Cost:** $B(R) + T(R) B(S)$
- Multiple-pass since S is read many times

What is the **Cost**?

Page-at-a-time Refinement

```
for each page of tuples r in R do  
  for each page of tuples s in S do  
    for all pairs of tuples  $t_1$  in r,  $t_2$  in s  
      if  $t_1$  and  $t_2$  join then output  $(t_1, t_2)$ 
```

What is the **Cost**?

Page-at-a-time Refinement

for each page of tuples r in R do
 for each page of tuples s in S do
 for all pairs of tuples t_1 in r , t_2 in s
 if t_1 and t_2 join then output (t_1, t_2)

- Cost: $B(R) + B(R)B(S)$

What is the Cost?

Page-at-a-time Refinement

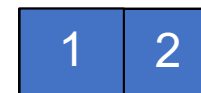
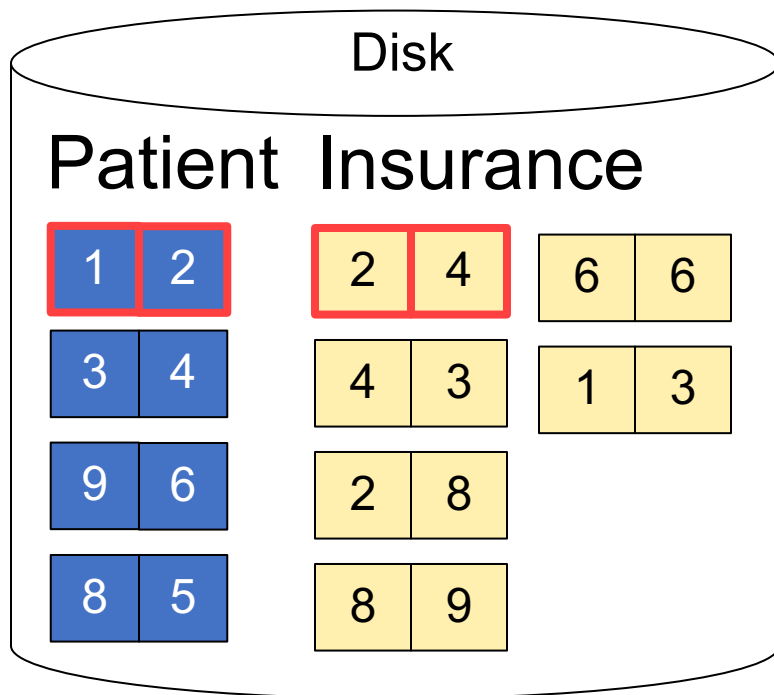

Input buffer for Patient

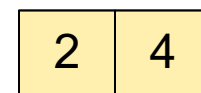

Input buffer for Insurance

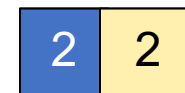

Output buffer

Page-at-a-time Refinement

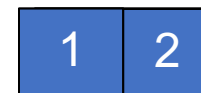
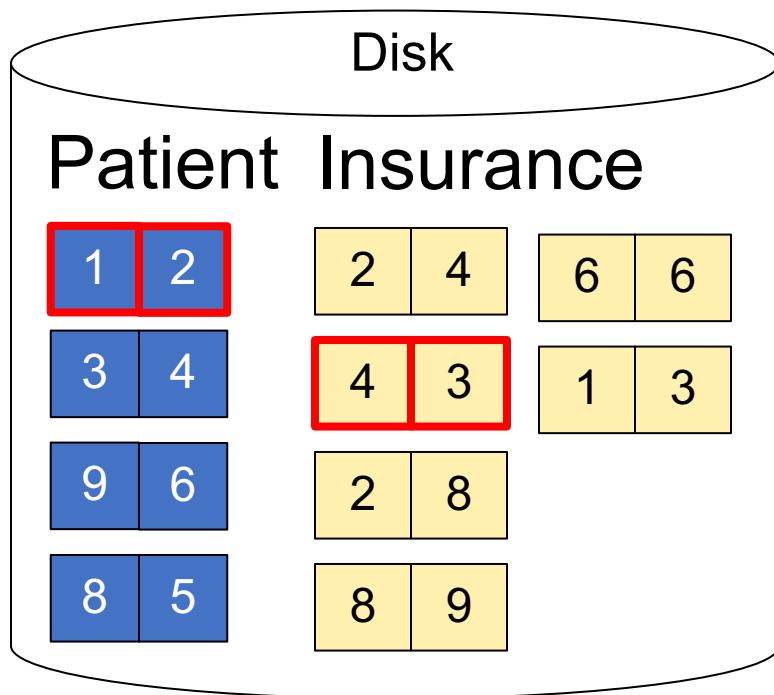

Input buffer for Patient

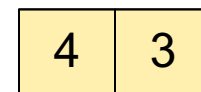

Input buffer for Insurance

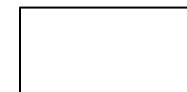

Output buffer

Page-at-a-time Refinement

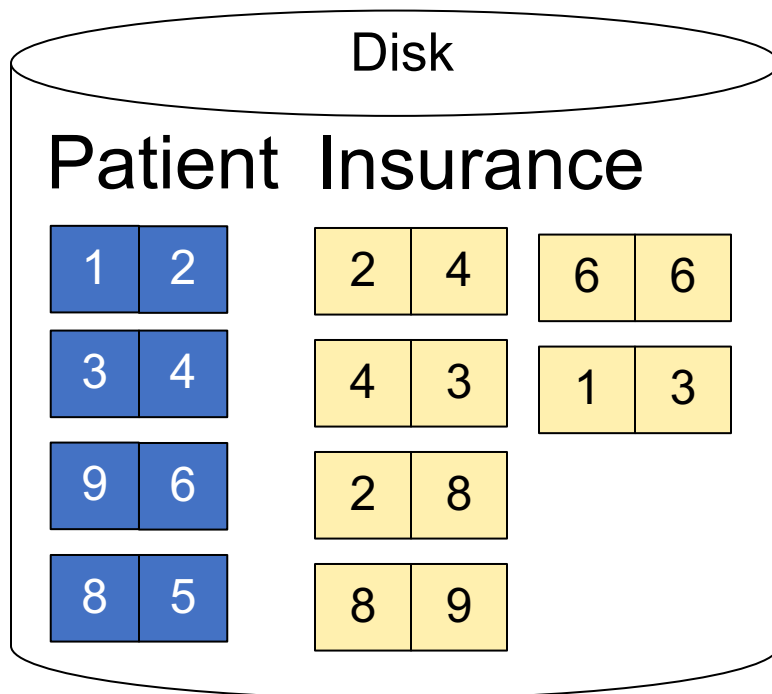

Input buffer for Patient

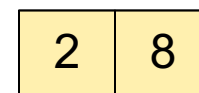

Input buffer for Insurance

Keep going until read all of Insurance

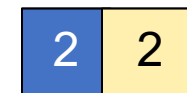

Output buffer

Then repeat for next page of Patient... until end of Patient

Cost: $B(R) + B(R)B(S)$

Block-Memory Refinement

```
for each group of M-1 pages r in R do  
  for each page of tuples s in S do  
    for all pairs of tuples t1 in r, t2 in s  
      if t1 and t2 join then output (t1,t2)
```

What is the **Cost**?

Block Memory Refinement

M= 3

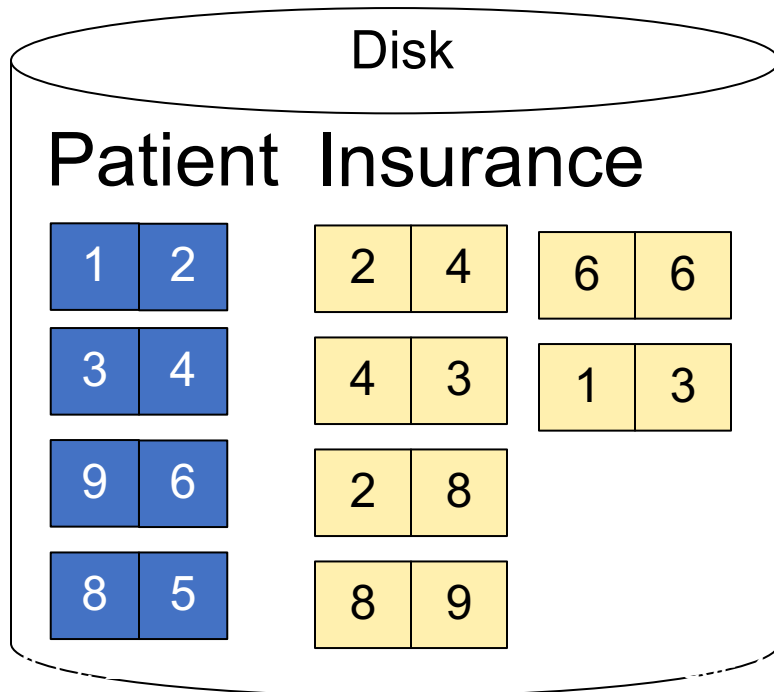

No output buffer: stream to output

Block Memory Refinement

M= 3

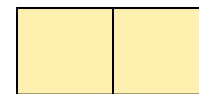
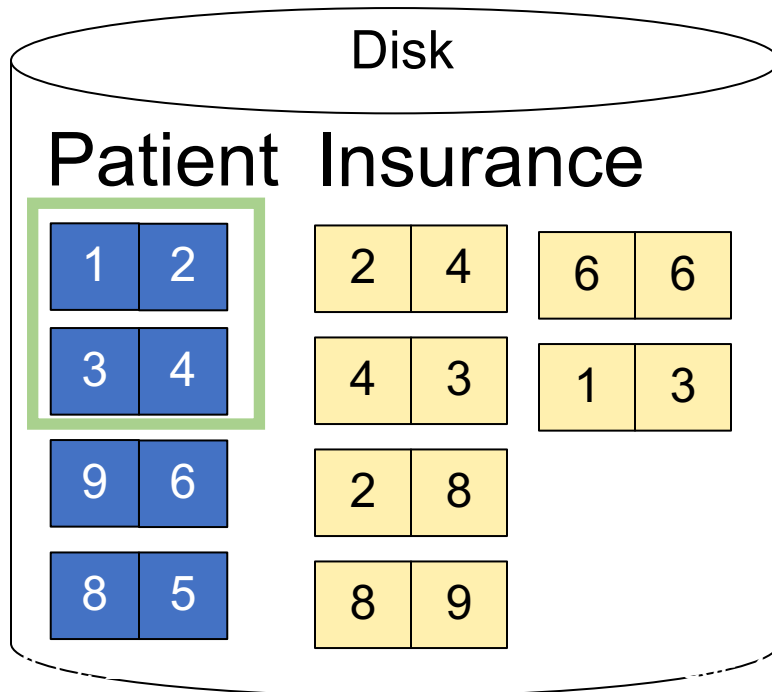

No output buffer: stream to output

Block Memory Refinement

M= 3

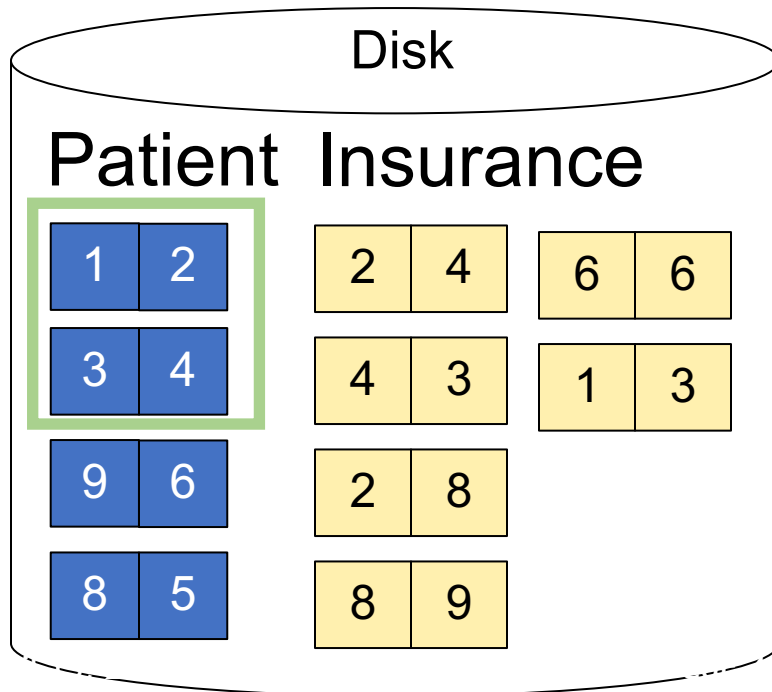

Input buffer for Patient

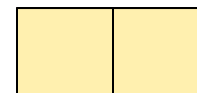
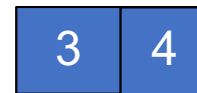

Input buffer for Insurance

No output buffer: stream to output

Block Memory Refinement

M= 3

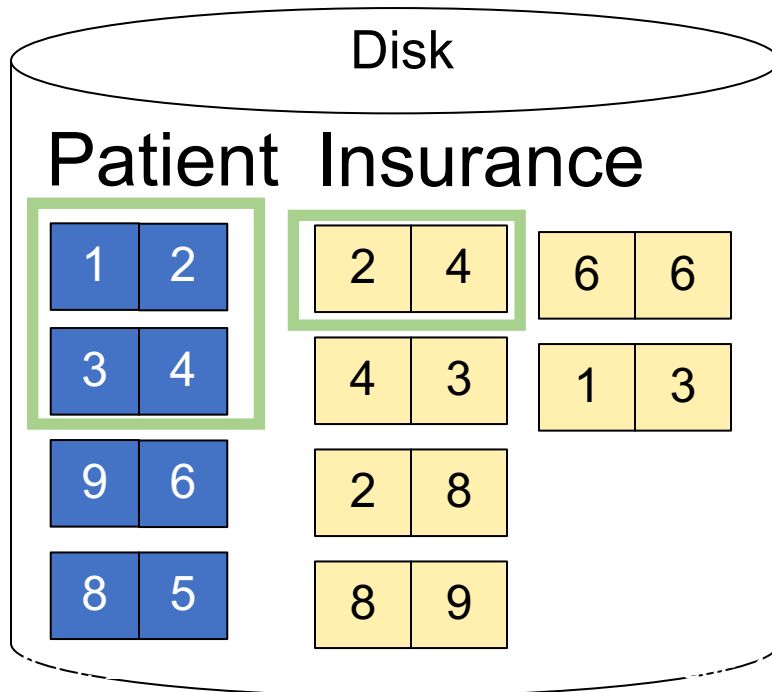

Input buffer for Patient

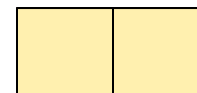
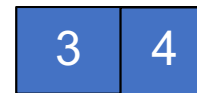

Input buffer for Insurance

No output buffer: stream to output

Block Memory Refinement

M= 3

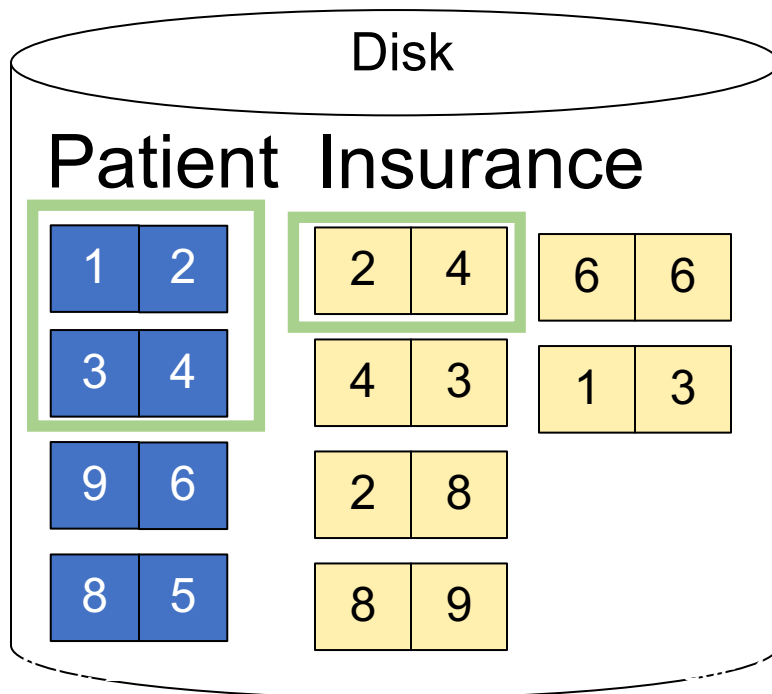

Input buffer for Patient

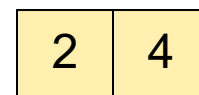
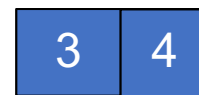

Input buffer for Insurance

No output buffer: stream to output

Block Memory Refinement

M= 3

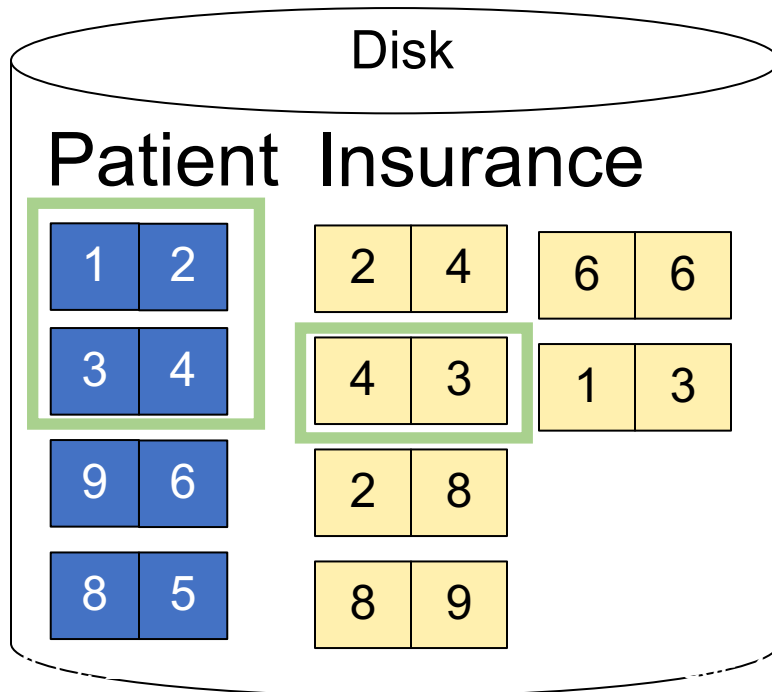

Input buffer for Patient

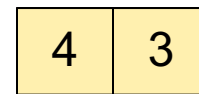
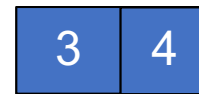

Input buffer for Insurance

No output buffer: stream to output

Block Memory Refinement

M= 3

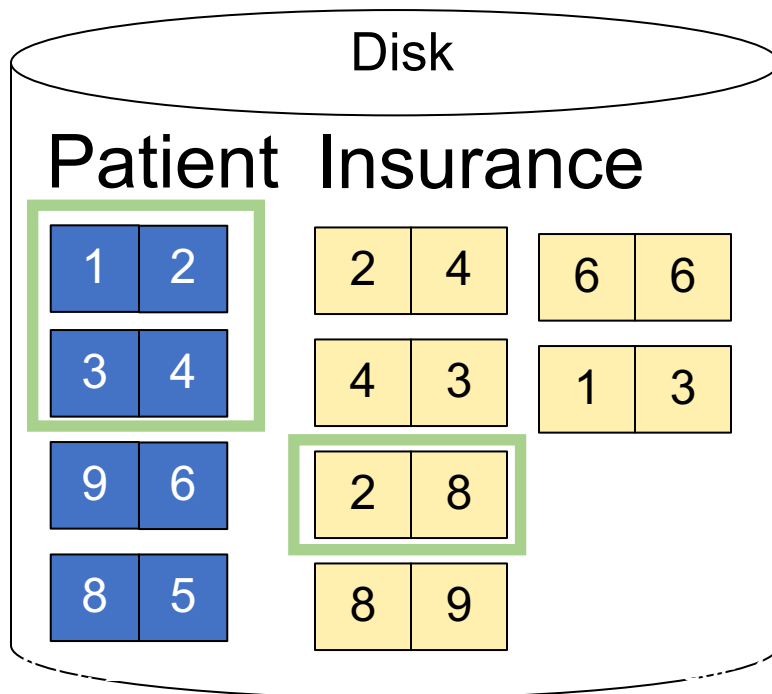

Input buffer for Patient

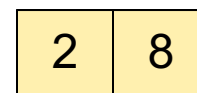
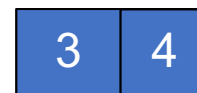

Input buffer for Insurance

No output buffer: stream to output

Block Memory Refinement

M= 3

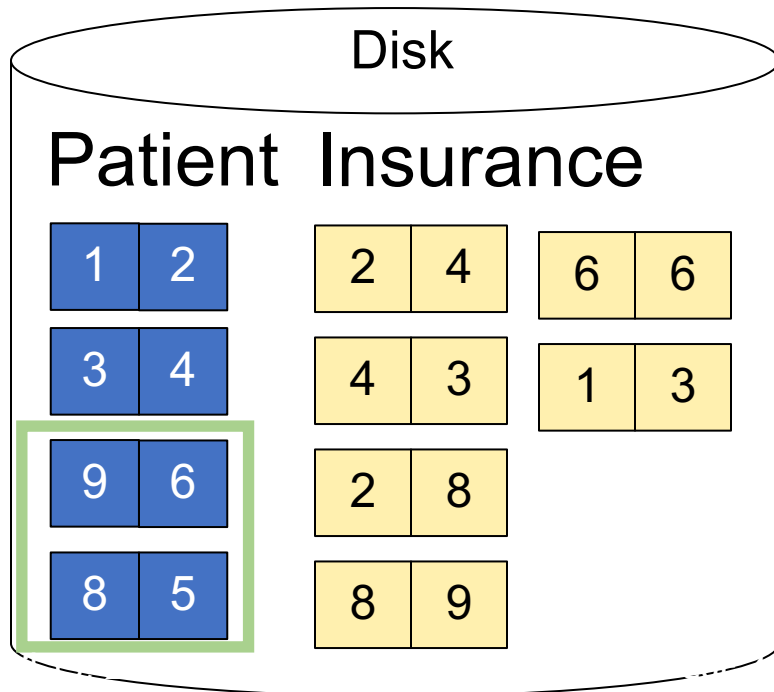

No output buffer: stream to output

Block Memory Refinement

M= 3

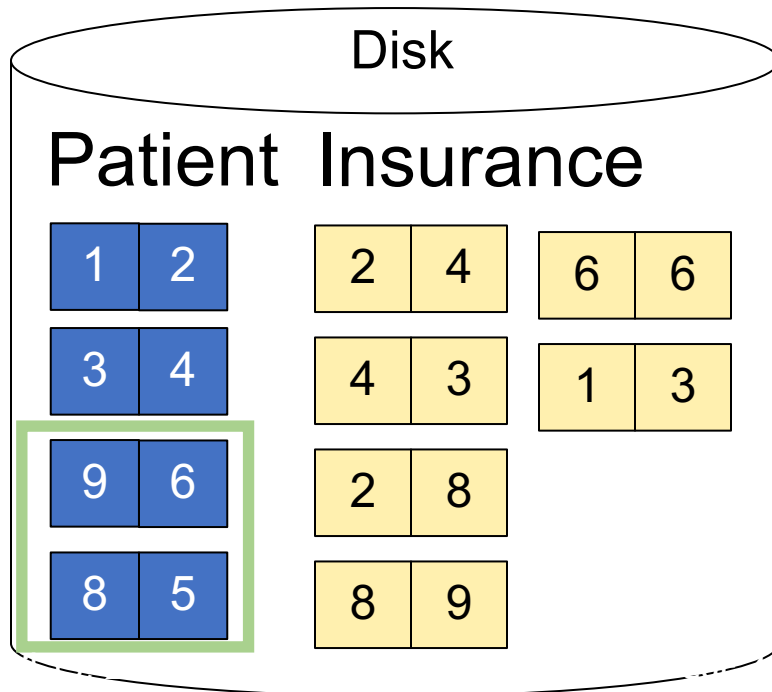

Input buffer for Patient



Input buffer for Insurance

No output buffer: stream to output

Block Memory Refinement

M= 3

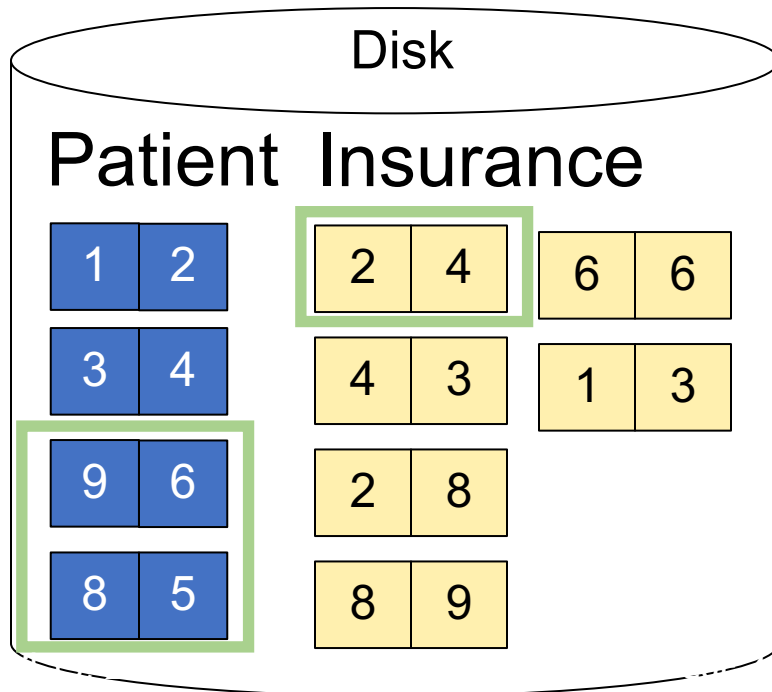

Input buffer for Patient

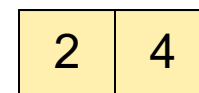
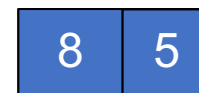

Input buffer for Insurance

No output buffer: stream to output

Block Memory Refinement

```
for each group of M-1 pages r in R do  
  for each page of tuples s in S do  
    for all pairs of tuples t1 in r, t2 in s  
      if t1 and t2 join then output (t1,t2)
```

What is the **Cost**

Block Memory Refinement

```
for each group of M-1 pages r in R do  
  for each page of tuples s in S do  
    for all pairs of tuples t1 in r, t2 in s  
      if t1 and t2 join then output (t1,t2)
```

- Cost: $B(R) + B(R)B(S)/(M-1)$

What is the Cost

Discussion

$R \bowtie S$: R =outer table, S =inner table

- Tuple-based nested loop join is never used
- Page-at-a-time nested loop join:
 - Usually combined with index access to inner table
 - Efficient when the outer table is small
- Block memory refinement nested loop:
 - Usually builds a hash table on the outer table
 - Efficient when the outer table is small

Sort-Merge Join

Sort-merge join: $R \bowtie S$

- Scan R and sort in main memory
- Scan S and sort in main memory
- Merge R and S

Sort-Merge Join

Sort-merge join: $R \bowtie S$

- Scan R and sort in main memory
- Scan S and sort in main memory
- Merge R and S

- Cost: $B(R) + B(S)$
- One pass algorithm when $B(S) + B(R) \leq M$
- Typically, this is NOT a one pass algorithm,
 - We'll see the multi-pass version next lecture

Sort-Merge Join Example

Step 1: Scan Patient and **sort** in memory

Memory M = 21 pages

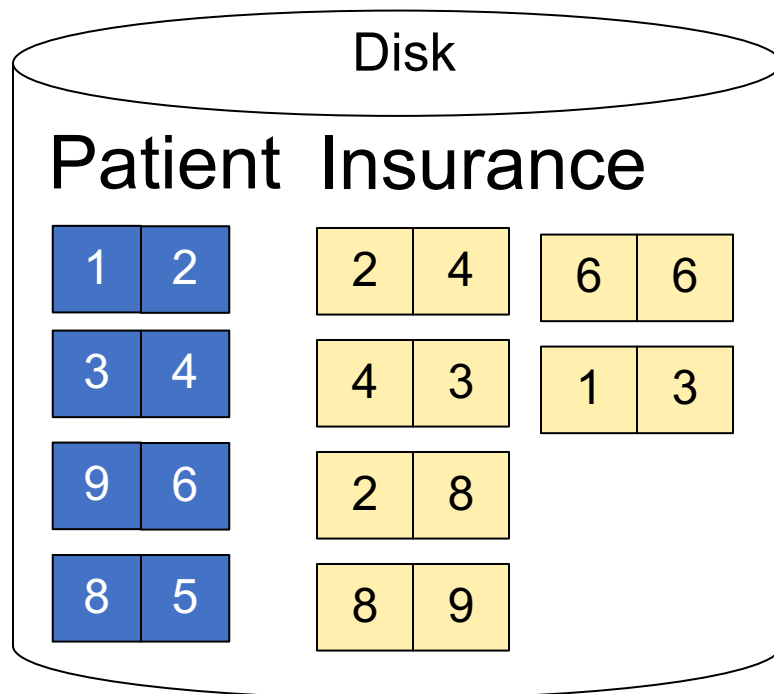

Sort-Merge Join Example

Step 2: Scan Insurance and **sort** in memory

Memory M = 21 pages

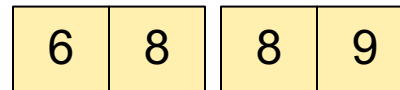
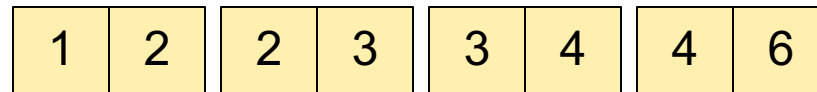
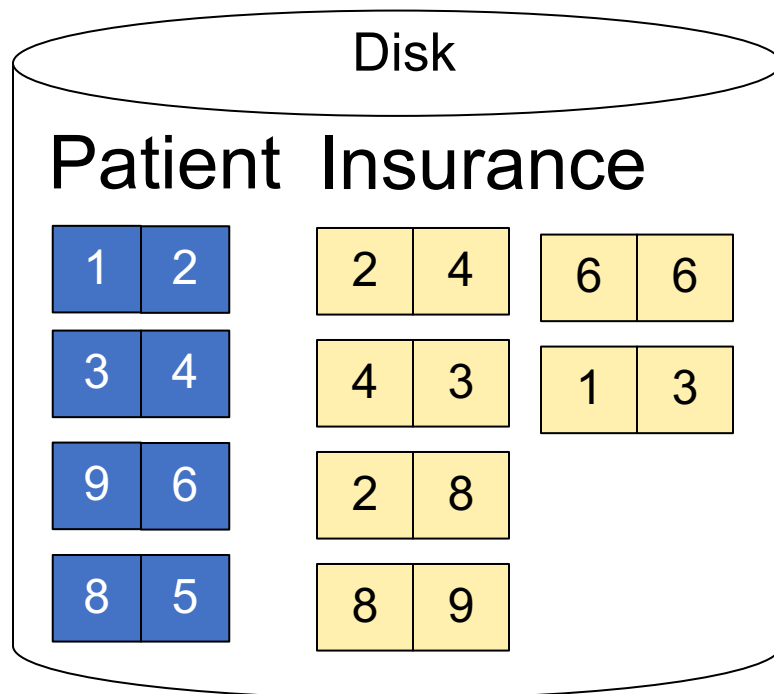

Sort-Merge Join Example

Step 3: Merge Patient and Insurance

Memory M = 21 pages

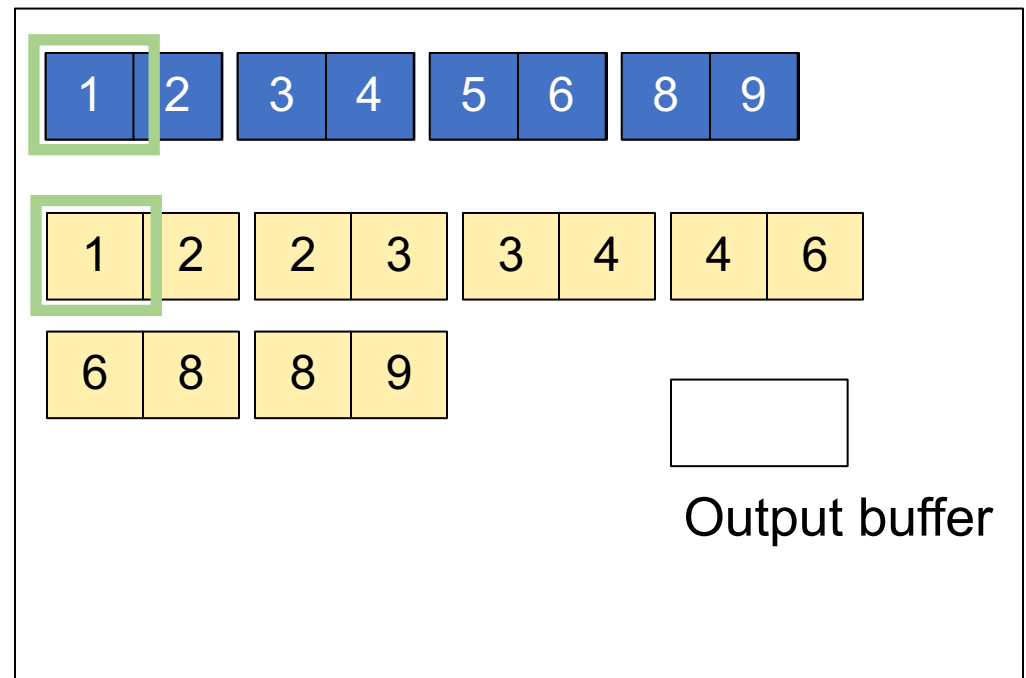
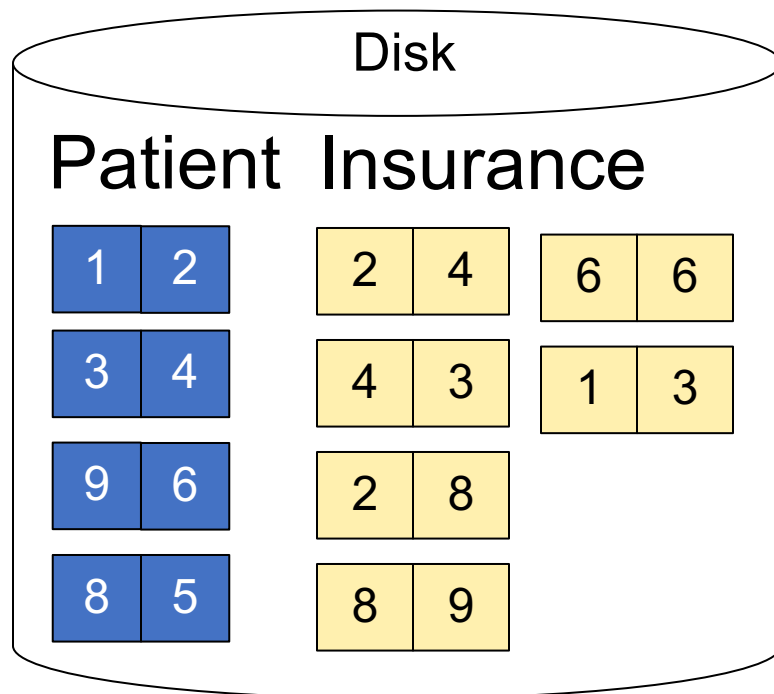

Sort-Merge Join Example

Step 3: Merge Patient and Insurance

Memory M = 21 pages

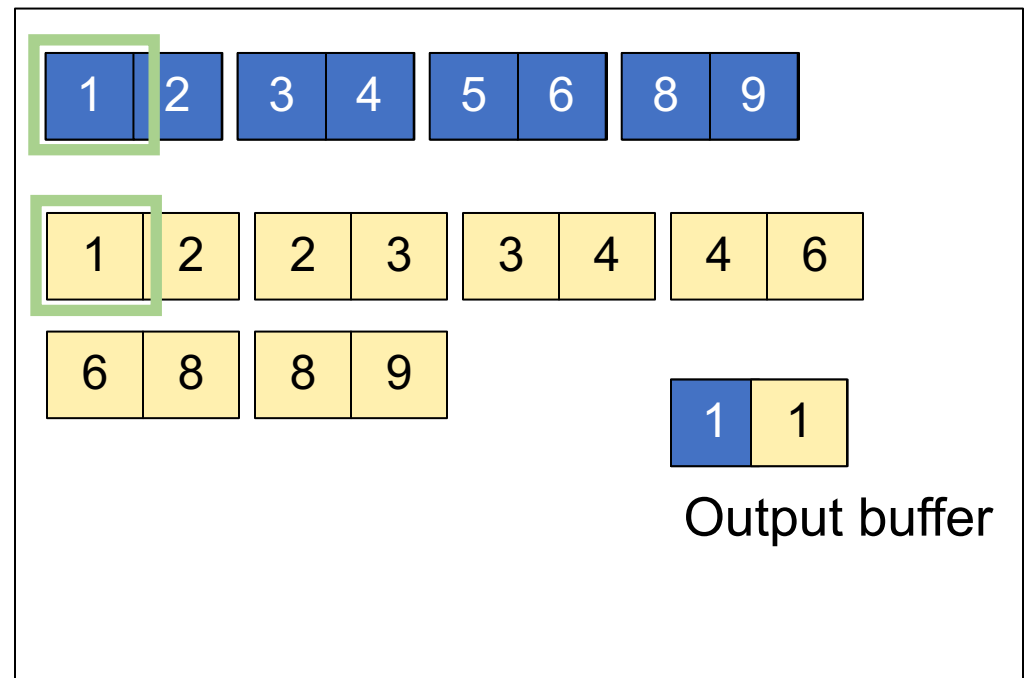
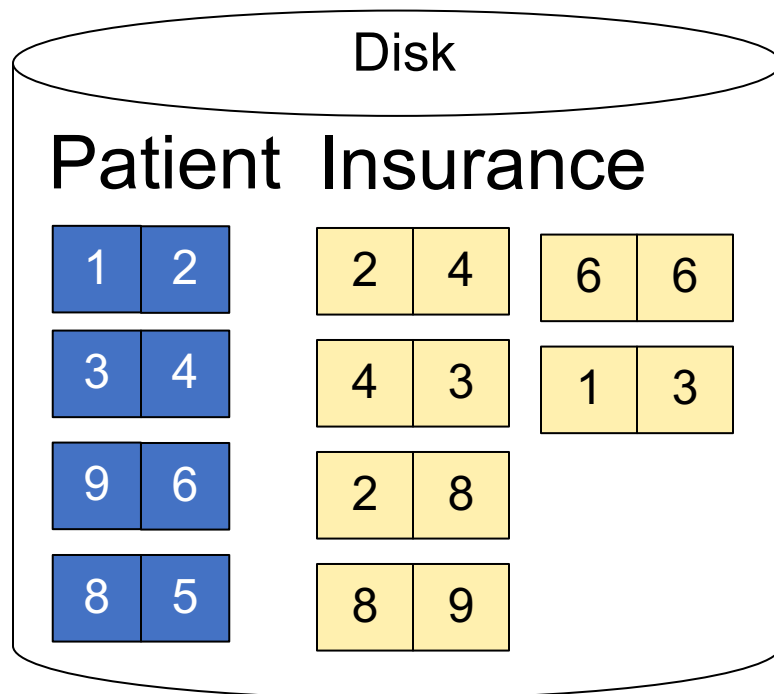

Sort-Merge Join Example

Step 3: Merge Patient and Insurance

Memory M = 21 pages

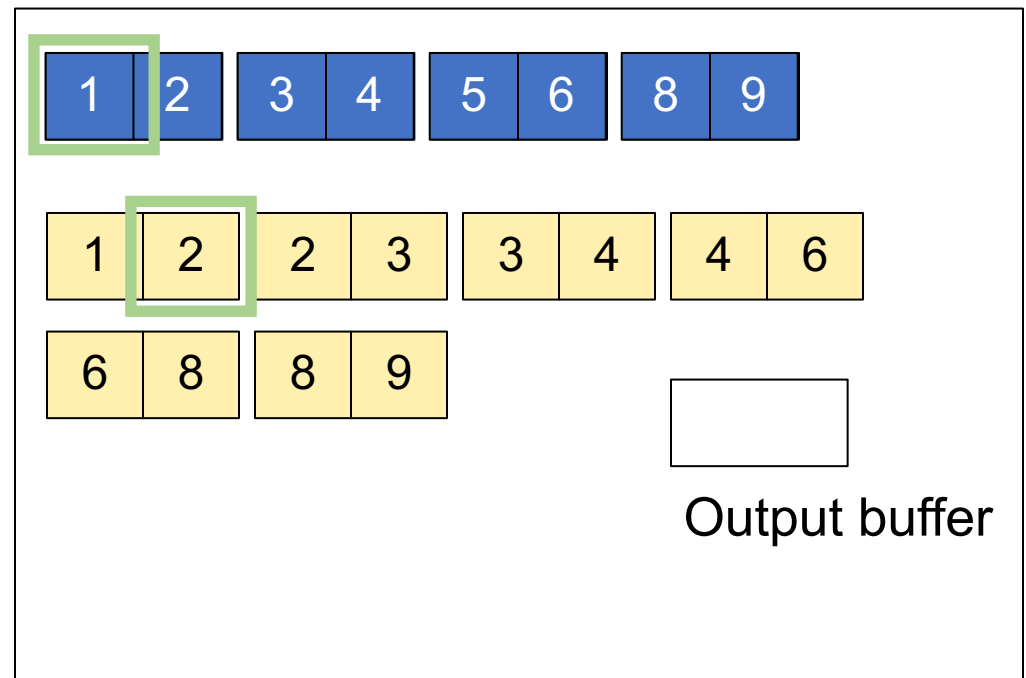
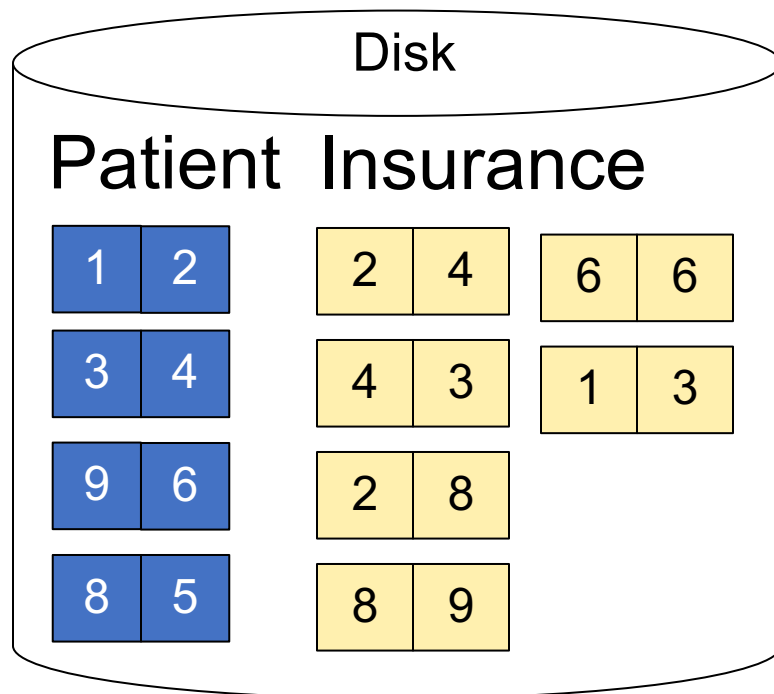

Sort-Merge Join Example

Step 3: Merge Patient and Insurance

Memory M = 21 pages

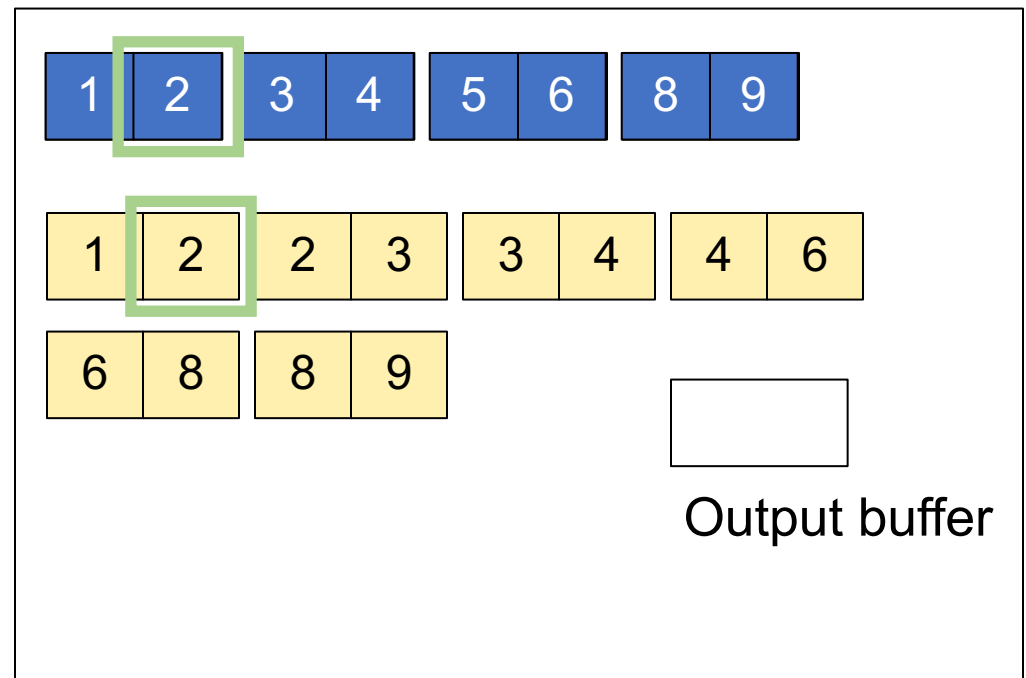
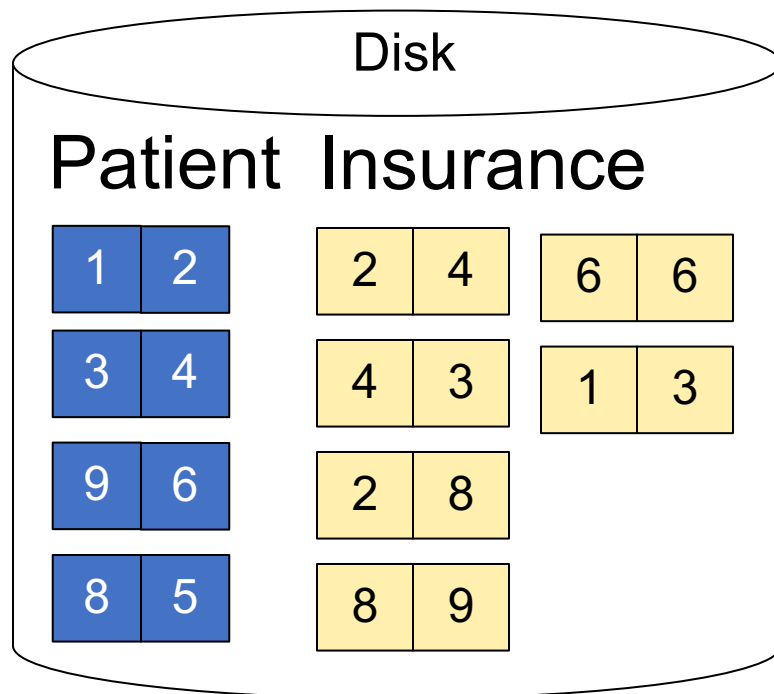

Sort-Merge Join Example

Step 3: Merge Patient and Insurance

Memory M = 21 pages

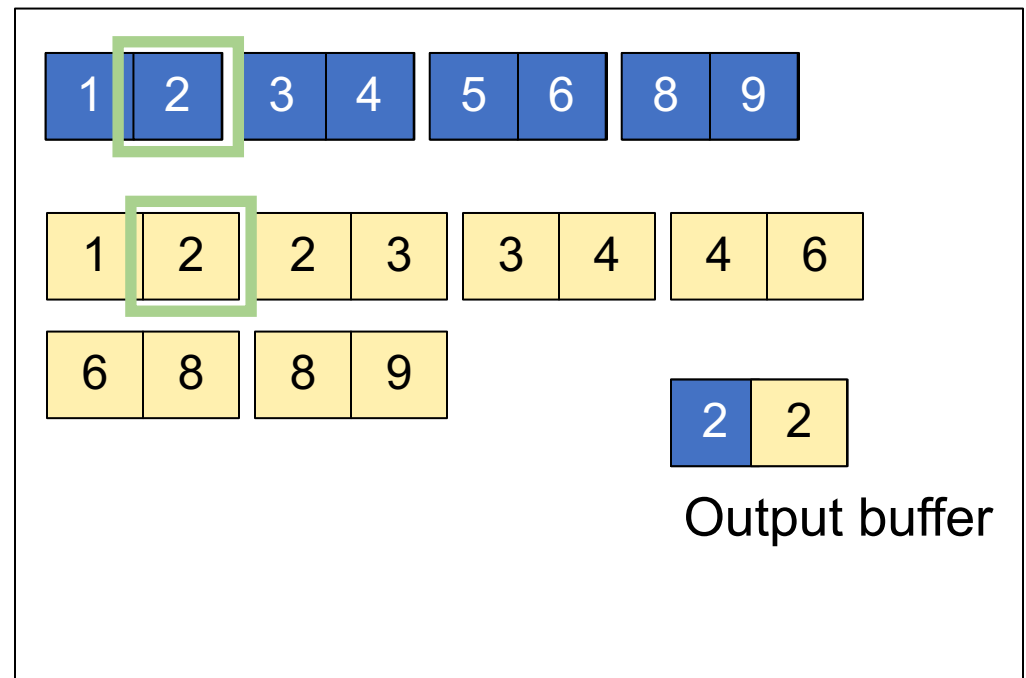
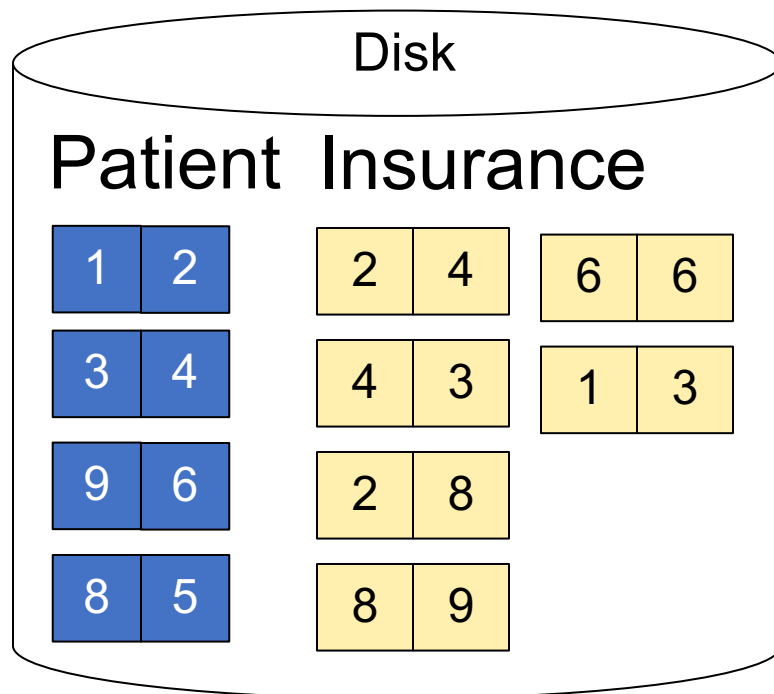

Sort-Merge Join Example

Step 3: Merge Patient and Insurance

Memory M = 21 pages

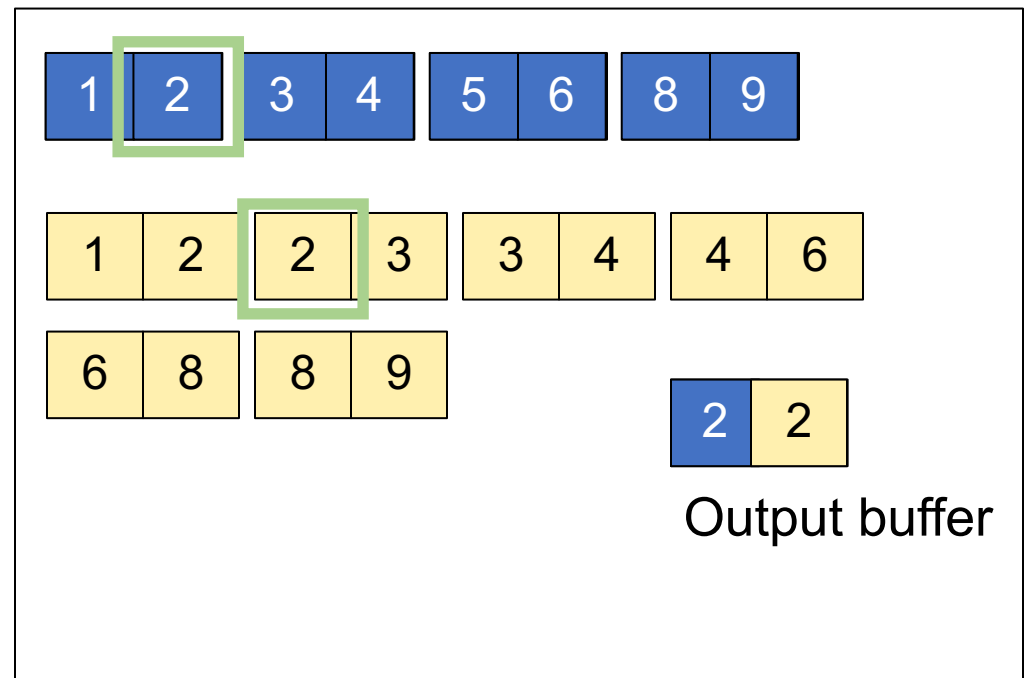
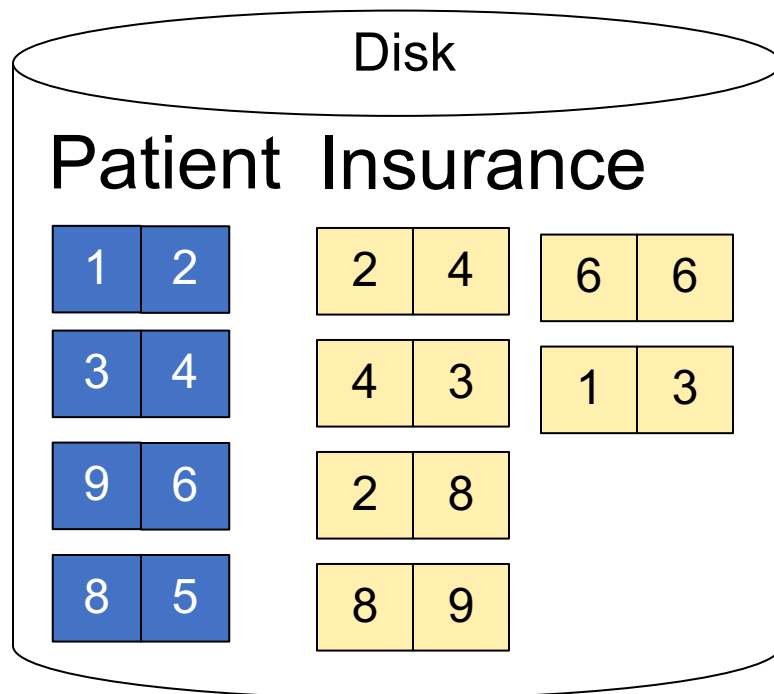

Sort-Merge Join Example

Step 3: Merge Patient and Insurance

Memory M = 21 pages

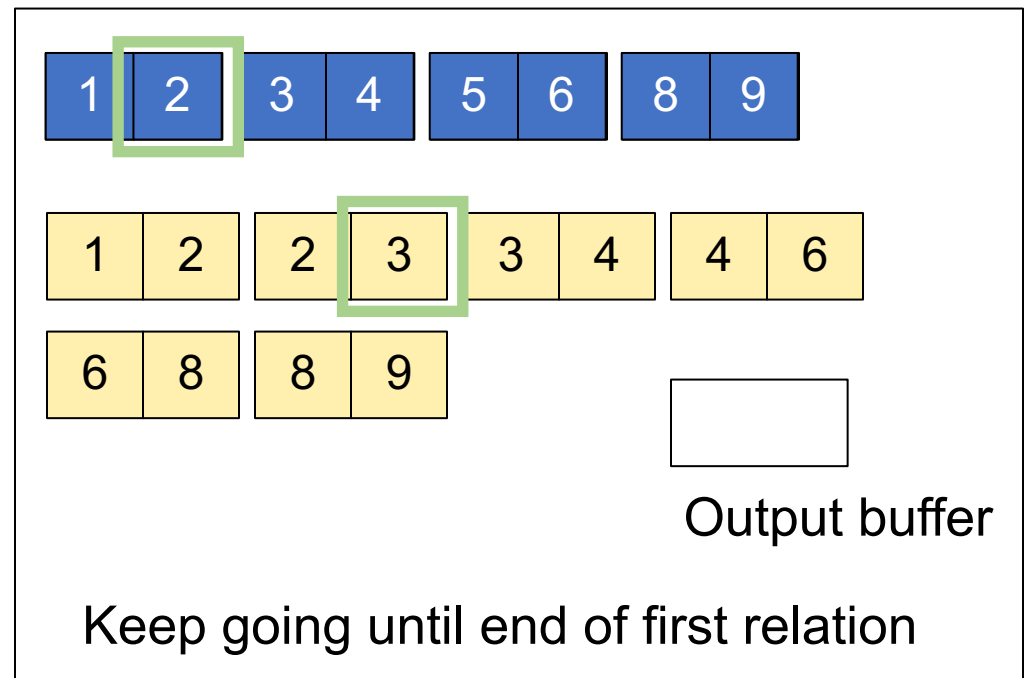
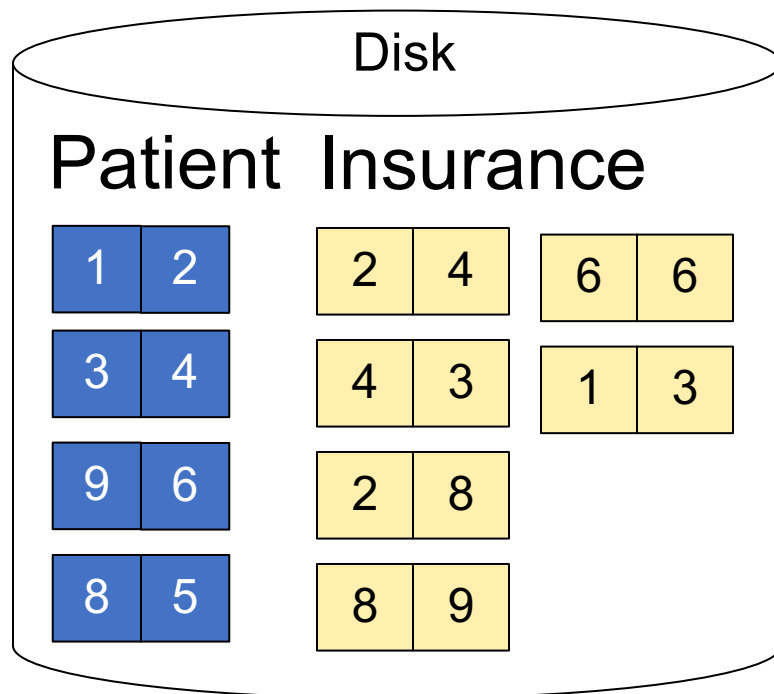

Outline

- **Join operator algorithms**
 - One-pass algorithms (Sec. 15.2 and 15.3)
 - **Index-based algorithms (Sec 15.6)**
 - Two-pass algorithms (Sec 15.4 and 15.5)

Index Based Selection

Selection on equality: $\sigma_{a=v}(R)$

- $B(R)$ = size of R in blocks
- $T(R)$ = number of tuples in R
- $V(R, a)$ = # of distinct values of attribute a

Note: we ignore I/O cost for index pages

Index Based Selection

Selection on equality: $\sigma_{a=v}(R)$

- $B(R)$ = size of R in blocks
- $T(R)$ = number of tuples in R
- $V(R, a)$ = # of distinct values of attribute a

What is the cost in each case?

- Clustered index on a :
- Unclustered index on a :

Note: we ignore I/O cost for index pages

Index Based Selection

Selection on equality: $\sigma_{a=v}(R)$

- $B(R)$ = size of R in blocks
- $T(R)$ = number of tuples in R
- $V(R, a)$ = # of distinct values of attribute a

What is the cost in each case?

- Clustered index on a : $B(R)/V(R, a)$
- Unclustered index on a :

Note: we ignore I/O cost for index pages

Index Based Selection

Selection on equality: $\sigma_{a=v}(R)$

- $B(R)$ = size of R in blocks
- $T(R)$ = number of tuples in R
- $V(R, a)$ = # of distinct values of attribute a

What is the cost in each case?

- Clustered index on a : $B(R)/V(R, a)$
- Unclustered index on a : $T(R)/V(R, a)$

Note: we ignore I/O cost for index pages

Index Based Selection

- **Example:**

$$\begin{aligned} B(R) &= 2000 \\ T(R) &= 100,000 \\ V(R, a) &= 20 \end{aligned}$$

$$\text{cost of } \sigma_{a=v}(R) = ?$$

- **Table scan:**
- **Index based selection:**

Index Based Selection

- **Example:**

$$\begin{aligned} B(R) &= 2000 \\ T(R) &= 100,000 \\ V(R, a) &= 20 \end{aligned}$$

$$\text{cost of } \sigma_{a=v}(R) = ?$$

- Table scan: $B(R) = 2,000$ I/Os
- Index based selection:

Index Based Selection

- **Example:**

$B(R) = 2000$
 $T(R) = 100,000$
 $V(R, a) = 20$

cost of $\sigma_{a=v}(R) = ?$

- **Table scan:** $B(R) = 2,000$ I/Os
- **Index based selection:**
 - If index is clustered:
 - If index is unclustered:

Index Based Selection

- **Example:**

$$\begin{aligned} B(R) &= 2000 \\ T(R) &= 100,000 \\ V(R, a) &= 20 \end{aligned}$$

$$\text{cost of } \sigma_{a=v}(R) = ?$$

- **Table scan:** $B(R) = 2,000$ I/Os
- **Index based selection:**
 - If index is clustered: $B(R)/V(R,a) = 100$ I/Os
 - If index is unclustered:

Index Based Selection

- **Example:**

$$\begin{aligned} B(R) &= 2000 \\ T(R) &= 100,000 \\ V(R, a) &= 20 \end{aligned}$$

$$\text{cost of } \sigma_{a=v}(R) = ?$$

- **Table scan:** $B(R) = 2,000$ I/Os
- **Index based selection:**
 - If index is clustered: $B(R)/V(R,a) = 100$ I/Os
 - If index is unclustered: $T(R)/V(R,a) = 5,000$ I/Os

Index Based Selection

- **Example:**

$$\begin{aligned} B(R) &= 2000 \\ T(R) &= 100,000 \\ V(R, a) &= 20 \end{aligned}$$

$$\text{cost of } \sigma_{a=v}(R) = ?$$

- **Table scan:** $B(R) = 2,000$ I/Os!
- **Index based selection:**
 - If index is clustered: $B(R)/V(R,a) = 100$ I/Os
 - If index is unclustered: $T(R)/V(R,a) = 5,000$ I/Os!

Index Based Selection

- **Example:**

$$\begin{aligned} B(R) &= 2000 \\ T(R) &= 100,000 \\ V(R, a) &= 20 \end{aligned}$$

$$\text{cost of } \sigma_{a=v}(R) = ?$$

- **Table scan:** $B(R) = 2,000$ I/Os!
- **Index based selection:**
 - If index is clustered: $B(R)/V(R,a) = 100$ I/Os
 - If index is unclustered: $T(R)/V(R,a) = 5,000$ I/Os!

Lesson: Don't build unclustered indexes when $V(R,a)$ is small !

Index Based Selection

- **Example:**

$$\begin{aligned} B(R) &= 2000 \\ T(R) &= 100,000 \\ V(R, a) &= 20 \end{aligned}$$

$$\text{cost of } \sigma_{a=v}(R) = ?$$

- **Table scan:** $B(R) = 2,000$ I/Os
- **Index based selection:**
 - If index is clustered: $B(R)/V(R,a) = 100$ I/Os
 - If index is unclustered: $T(R)/V(R,a) = 5,000$ I/Os

Lesson: Don't build unclustered indexes when $V(R,a)$ is small !

Index Nested Loop Join

$R \bowtie S$

- Assume S has an index on the join attribute
- Iterate over R , for each tuple fetch corresponding tuple(s) from S

- Previous nested loop join: cost
 - $B(R) + T(R) * B(S)$
- **Index Nested Loop Join Cost:**
 - If index on S is clustered: $B(R) + T(R)B(S)/V(S,a)$
 - If index on S is unclustered: $B(R) + T(R)T(S)/V(S,a)$

Outline

- **Join operator algorithms**
 - One-pass algorithms (Sec. 15.2 and 15.3)
 - Index-based algorithms (Sec 15.6)
 - Two-pass algorithms (Sec 15.4 and 15.5)

Two-Pass Algorithms

- Fastest algorithm seen so far is one-pass hash join
What if data does not fit in memory?
- Need to process it in multiple passes

- Two key techniques
 - **Sorting**
 - **Hashing**

Basic Terminology

- A run in a sequence is an increasing subsequence
- What are the runs?

2, 4, 99, 103, 88, 77, 3, 79, 100, 2, 50

Basic Terminology

- A run in a sequence is an increasing subsequence
- What are the runs?

2, 4, 99, 103, | 88, | 77, | 3, 79, 100, | 2, 50

External Merge-Sort: Step 1

Phase one: load M blocks in memory, sort, send to disk, repeat

External Merge-Sort: Step 1

Phase one: load M blocks in memory, sort, send to disk, repeat

Q: How long are the runs?

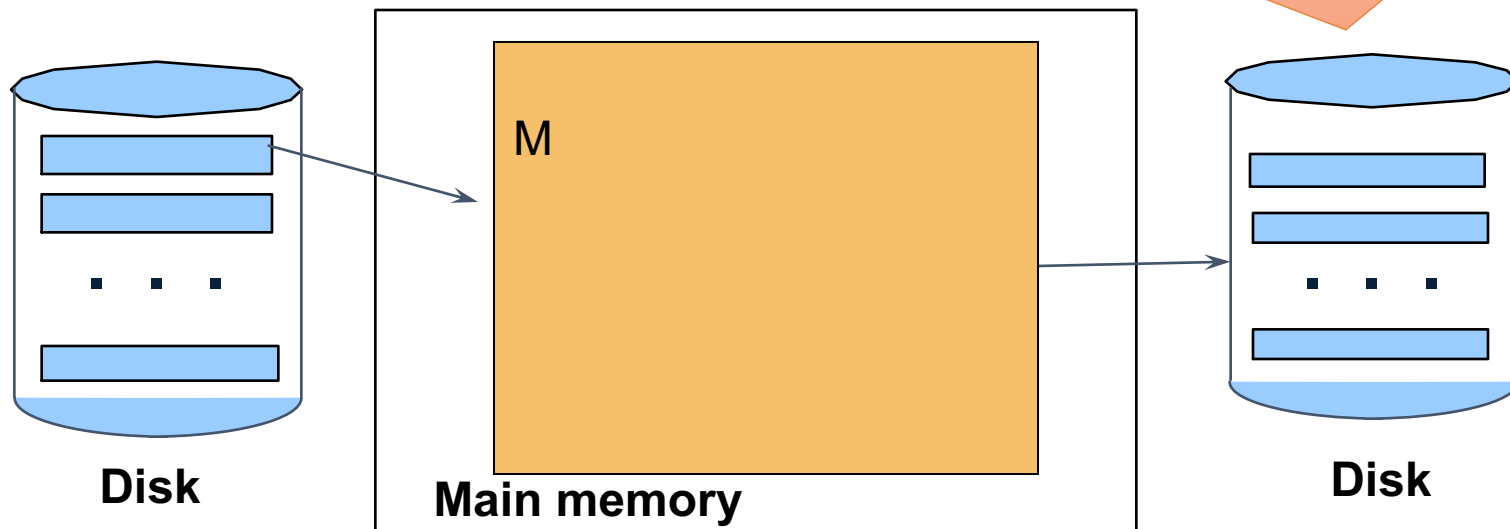

External Merge-Sort: Step 1

Phase one: load M blocks in memory, sort, send to disk, repeat

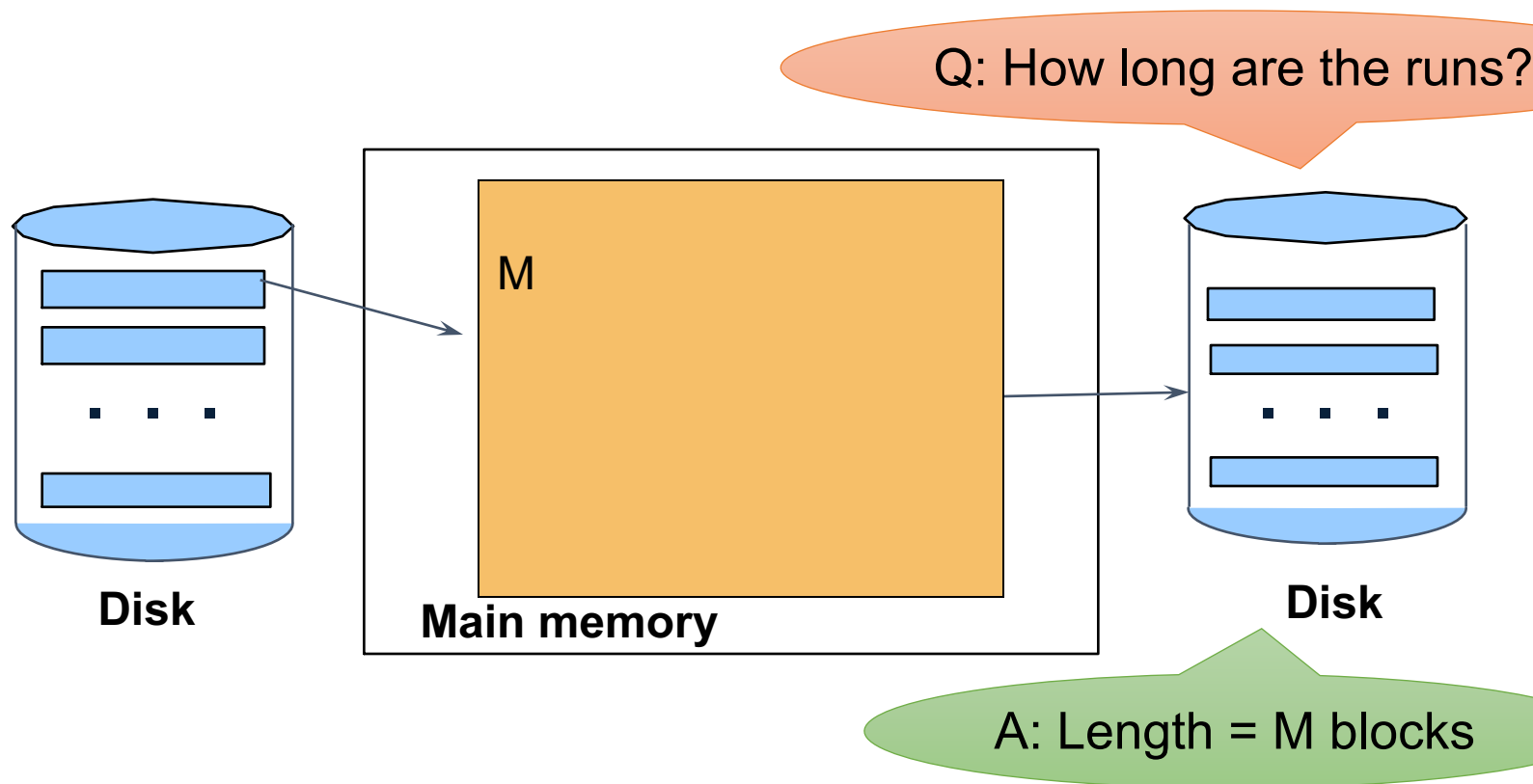

Phase two: merge M runs into a bigger run

- Merge $M - 1$ runs into a new run
- Result: runs of length $M(M - 1) \approx M^2$

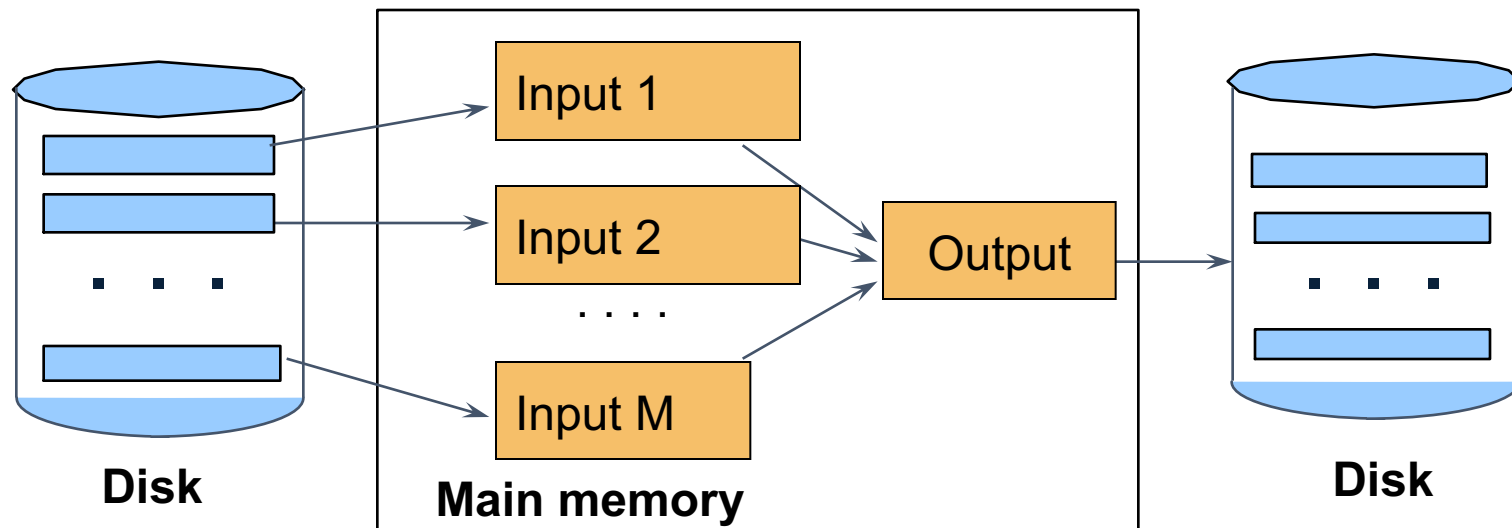

Example

- Merging three runs to produce a longer run:

0, 14, 33, 88, 92, 192, 322

2, 4, 7, 43, 78, 103, 523

1, 6, 9, 12, 33, 52, 88, 320

Output:

0

Example

- Merging three runs to produce a longer run:

0, **14**, **33**, **88**, **92**, **192**, **322**

2, **4**, **7**, **43**, **78**, **103**, **523**

1, **6**, **9**, **12**, **33**, **52**, **88**, **320**

Output:

0, **?**

Example

- Merging three runs to produce a longer run:

0, **14**, 33, 88, 92, 192, 322

2, 4, 7, 43, 78, 103, 523

1, **6**, 9, 12, 33, 52, 88, 320

Output:

0, 1, **?**

Example

- Merging three runs to produce a longer run:

0, **14**, 33, 88, 92, 192, 322

2, 4, 7, **43**, 78, 103, 523

1, 6, **9**, 12, 33, 52, 88, 320

Output:

0, 1, 2, 4, 6, 7, **?**

External Merge-Sort: Step 2

Phase two: merge M runs into a bigger run

- Merge $M - 1$ runs into a new run
- Result: runs of length $M(M - 1) \approx M^2$

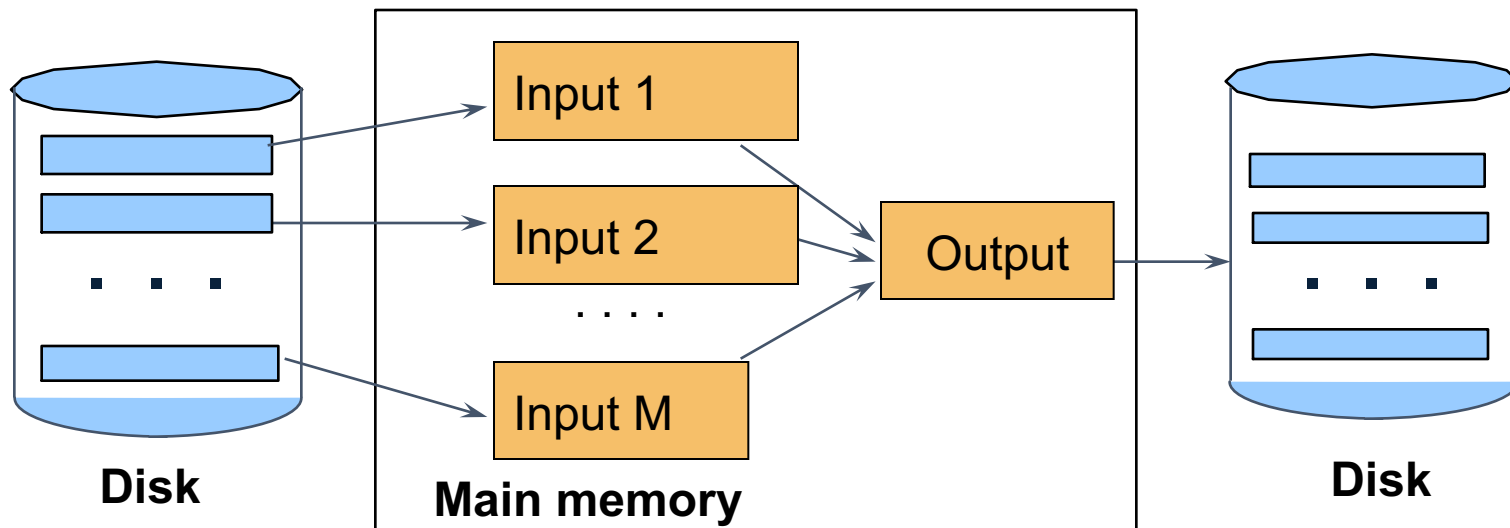

If approx. $B \leq M^2$ then we are done

Cost of External Merge Sort

- Assumption: $B(R) \leq M^2$
- Read+write+read = $3B(R)$

Discussion

- What does $B(R) \leq M^2$ mean?
- How large can R be?

Discussion

- What does $B(R) \leq M^2$ mean?
- How large can R be?

- Example:
 - Page size = 32KB
 - Memory size 32GB: $M = 10^6$ -pages

Discussion

- What does $B(R) \leq M^2$ mean?
- How large can R be?

- Example:
 - Page size = 32KB
 - Memory size 32GB: $M = 10^6$ pages

- R can be as large as 10^{12} pages
 - 32×10^{15} Bytes = 32 PB

Merge-Join

Join $R \bowtie S$

- How?.....

Merge-Join

Join $R \bowtie S$

- Step 1a: generate initial runs for R
- Step 1b: generate initial runs for S
- Step 2: merge and join
 - Either merge first and then join
 - Or merge & join at the same time

Merge-Join Example

Setup: Want to join R and S

Relation R has 10 pages with 2 tuples per page

Relation S has 8 pages with 2 tuples per page

Values shown are values of join attribute for each given tuple

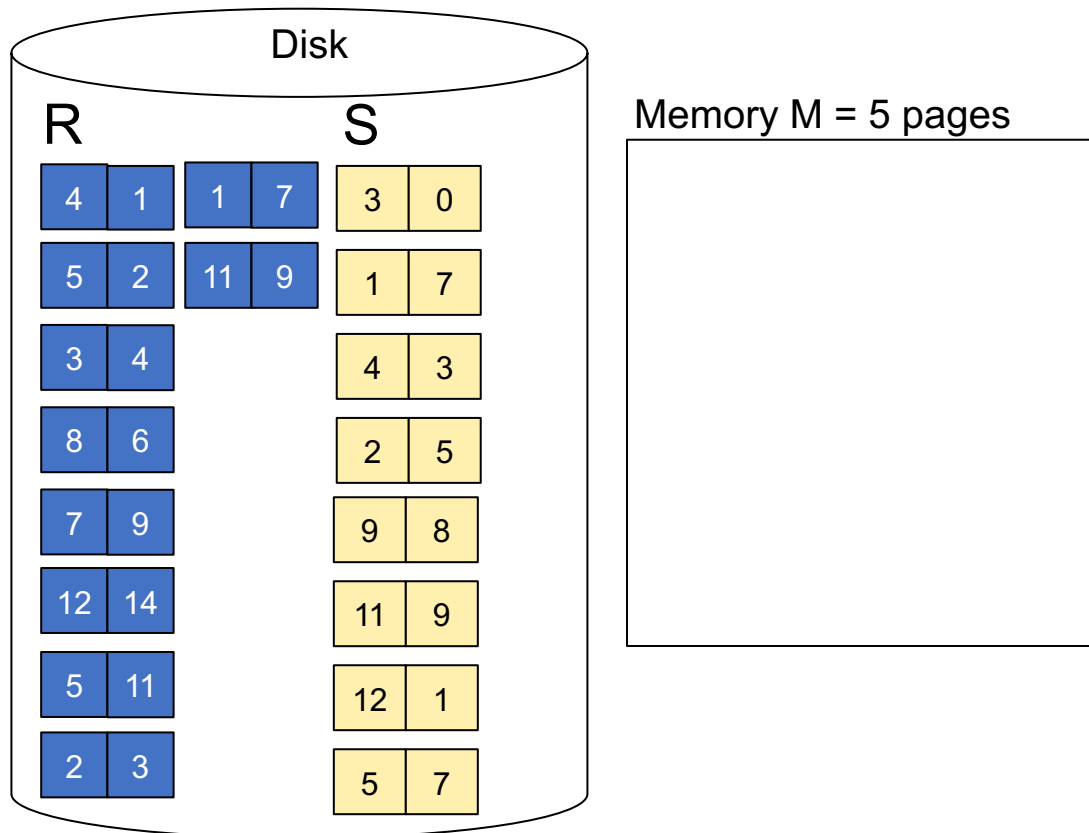

Merge-Join Example

Step 1: Read M pages of R and sort in memory

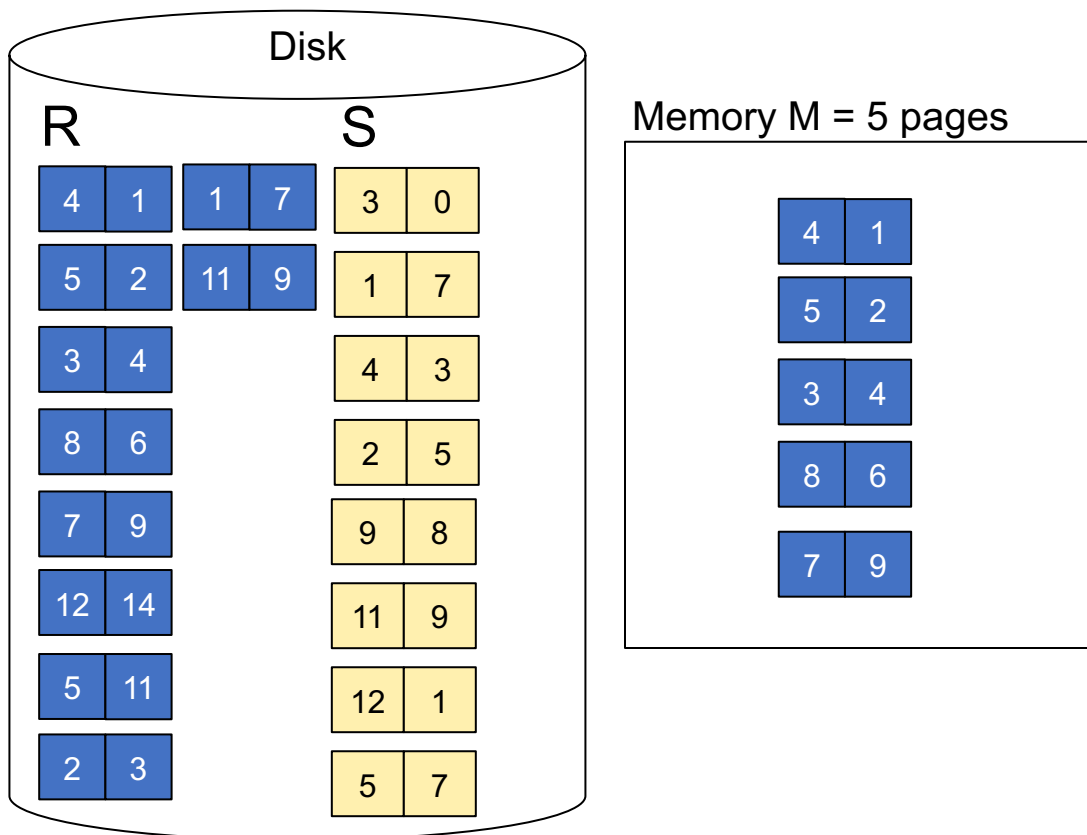

Merge-Join Example

Step 1: Read M pages of R and sort in memory, then write to disk

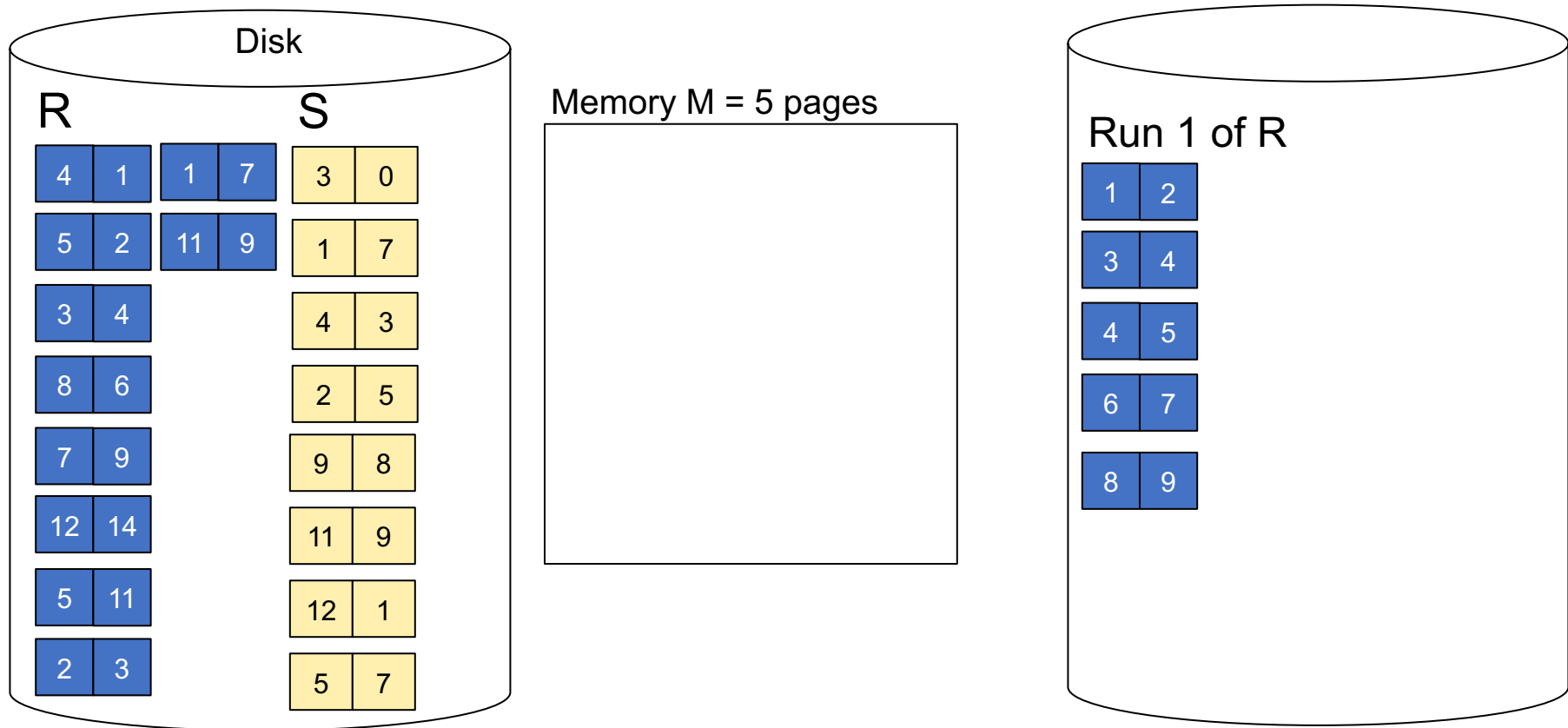

Merge-Join Example

Step 1: Repeat for next M pages until all R is processed

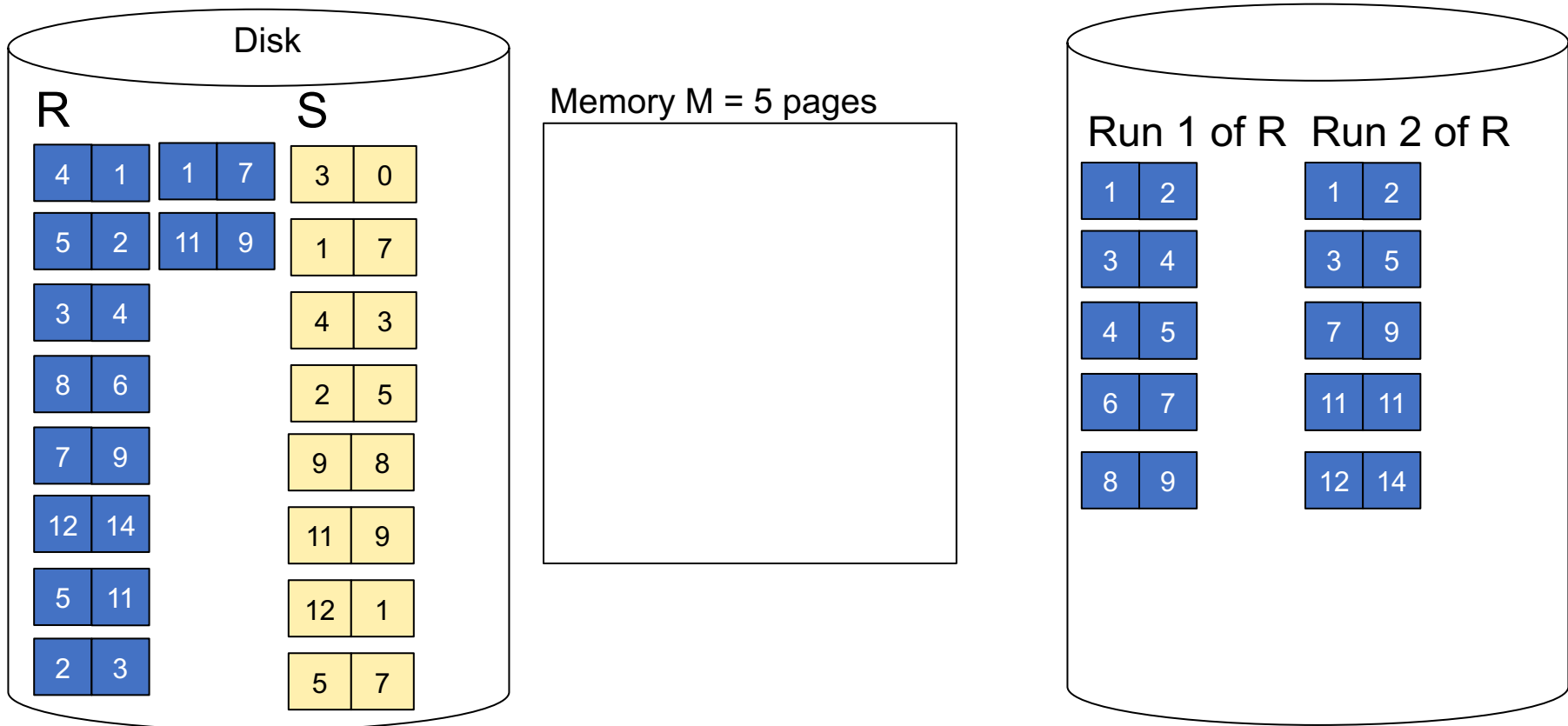

Merge-Join Example

Step 1: Do the same with S

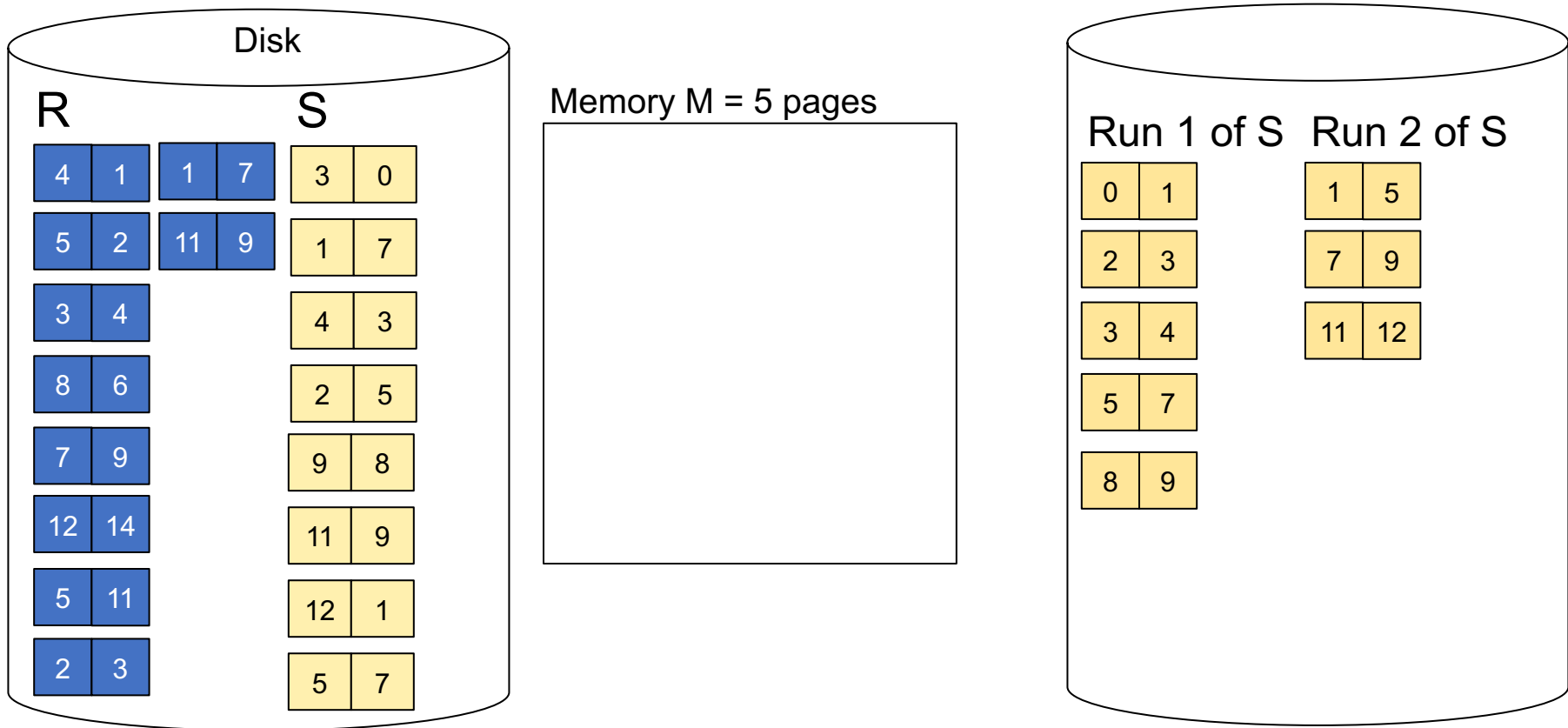

Merge-Join Example

Step 2: Join while merging sorted runs

Total cost: $3B(R) + 3B(S)$

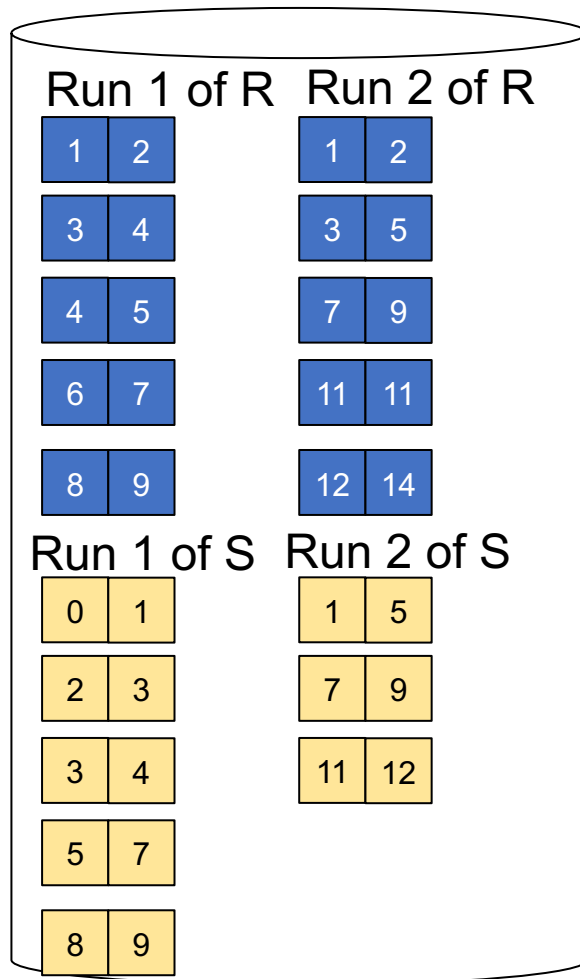

Memory M = 5 pages

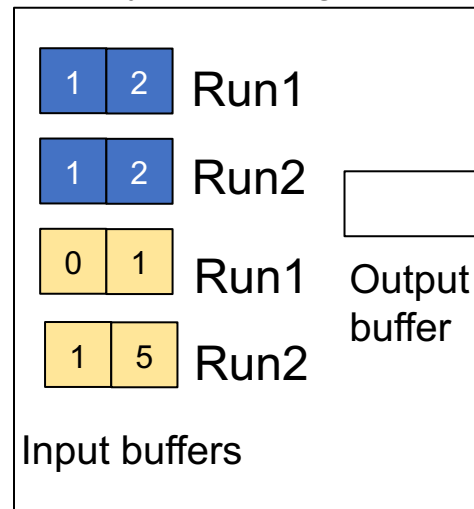

Step 2: Join while merging
Output tuples

Merge-Join Example

Step 2: Join while merging sorted runs

Total cost: $3B(R) + 3B(S)$

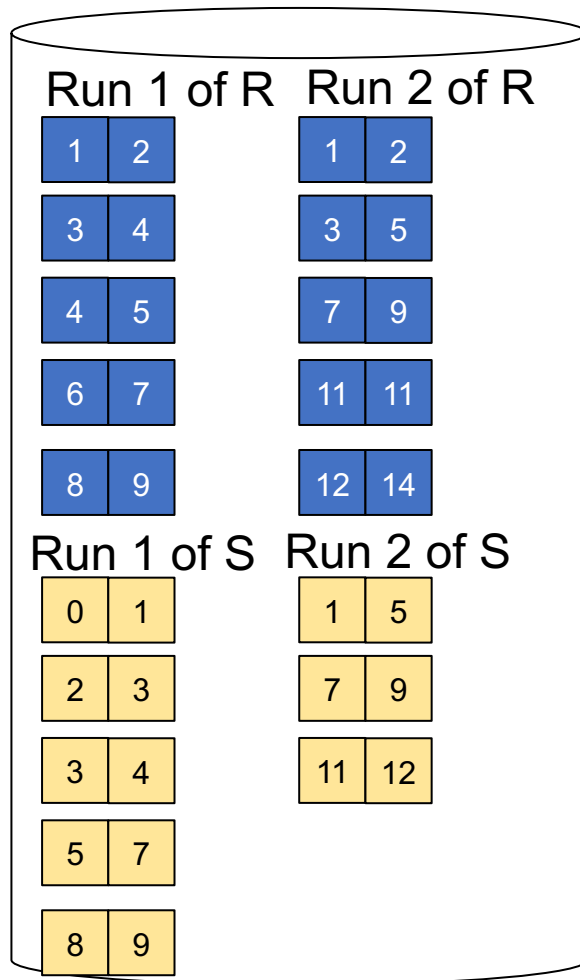

Memory M = 5 pages

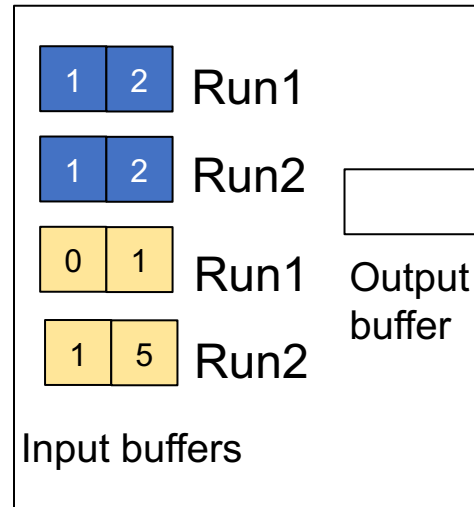

Step 2: Join while merging
Output tuples

Merge-Join Example

Step 2: Join while merging sorted runs

Total cost: $3B(R) + 3B(S)$

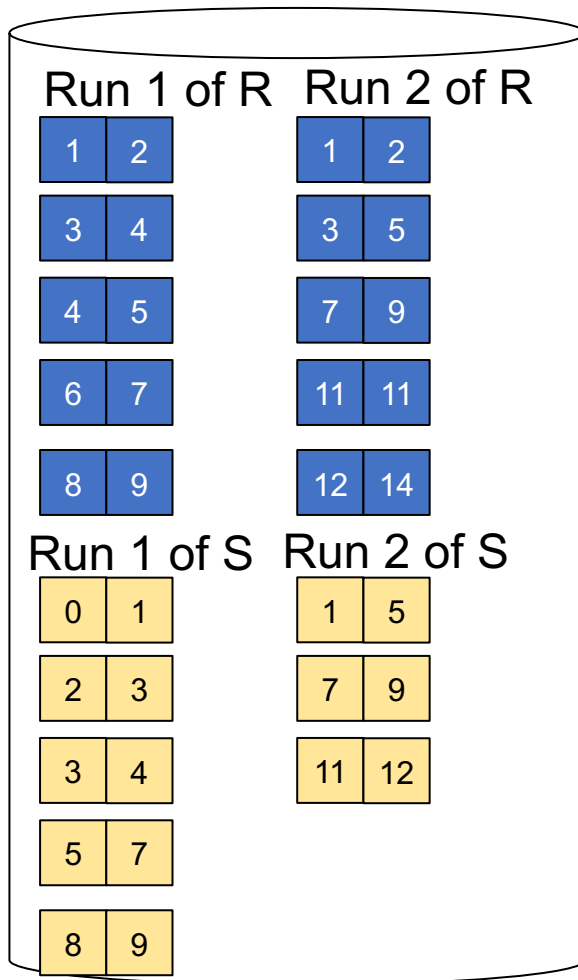

Memory M = 5 pages

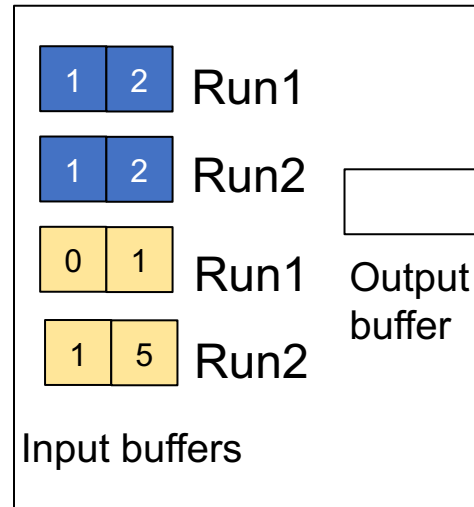

Step 2: Join while merging

Output tuples

- (1,1)
- (1,1)
- (1,1)
- (1,1)

Merge-Join Example

Step 2: Join while merging sorted runs

Total cost: $3B(R) + 3B(S)$

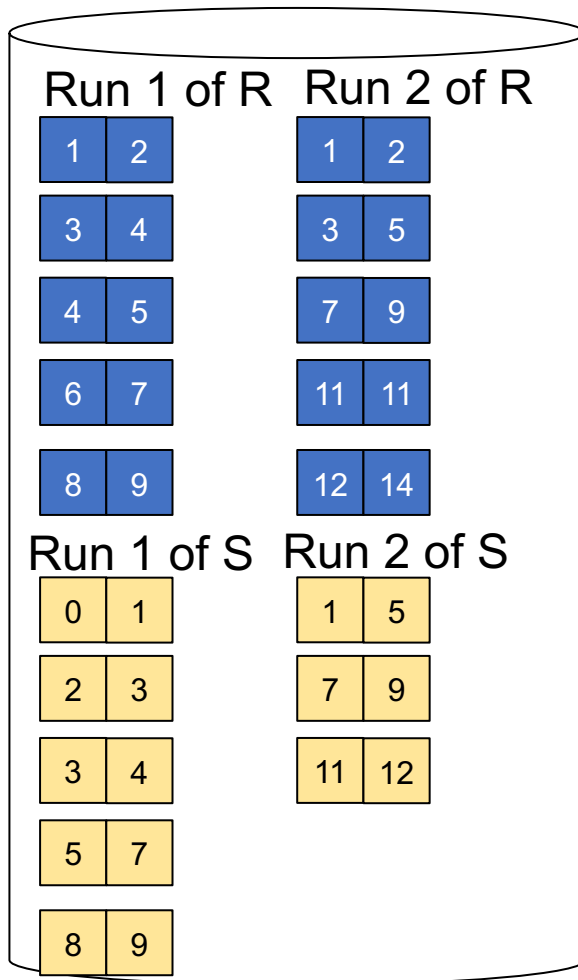

Memory M = 5 pages

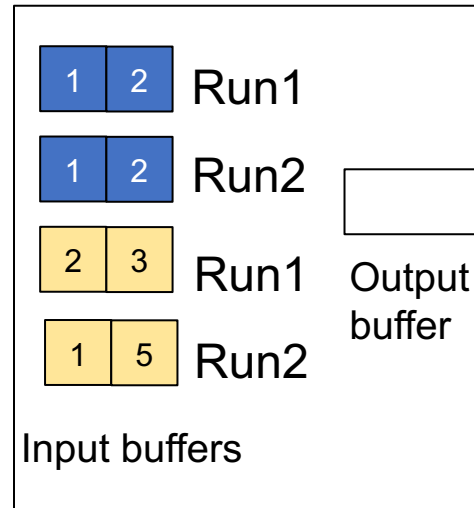

Step 2: Join while merging
Output tuples

- (1,1)
- (1,1)
- (1,1)
- (1,1)

Merge-Join Example

Step 2: Join while merging sorted runs

Total cost: $3B(R) + 3B(S)$

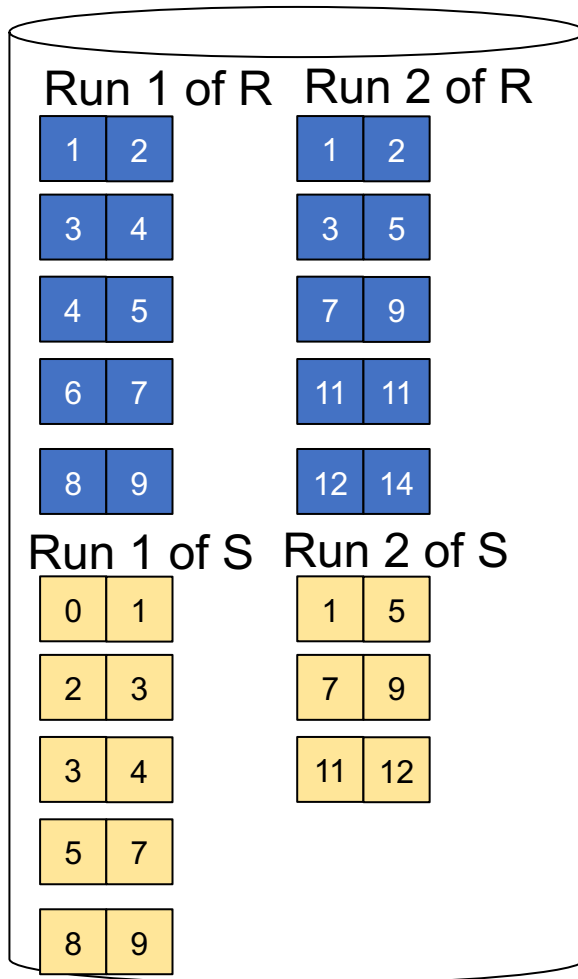

Memory M = 5 pages

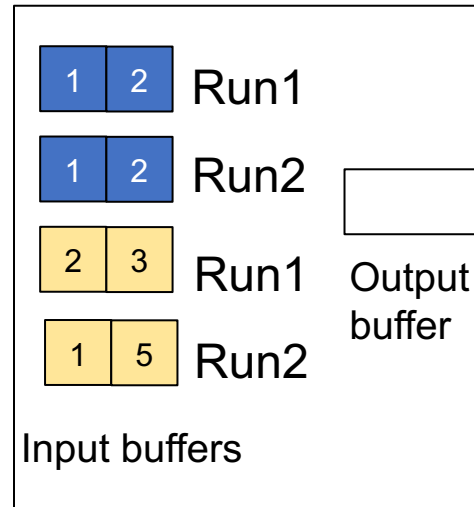

Step 2: Join while merging

Output tuples

- (1,1)
- (1,1)
- (1,1)
- (1,1)
- (2,2)
- (2,2)

Merge-Join Example

Step 2: Join while merging sorted runs

Total cost: $3B(R) + 3B(S)$

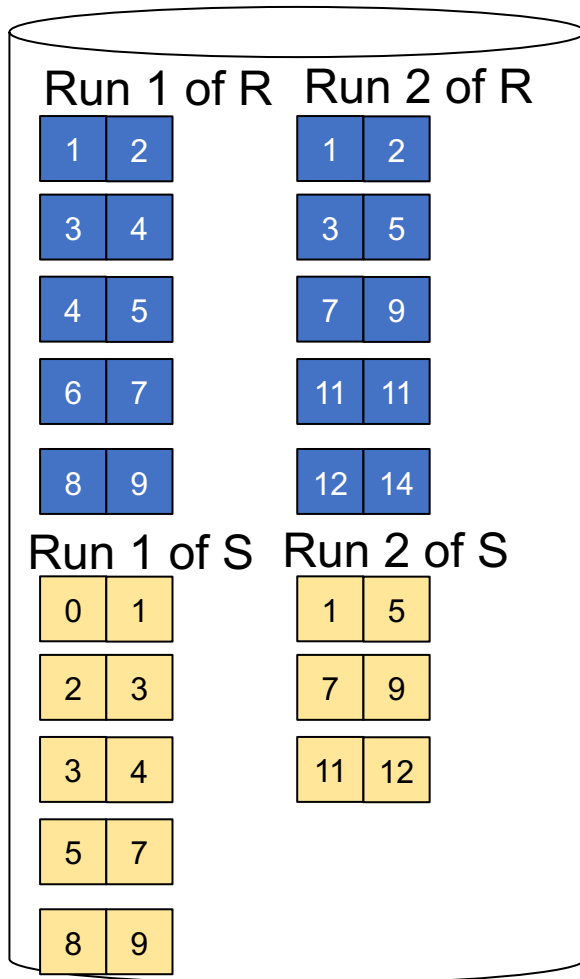

Memory M = 5 pages

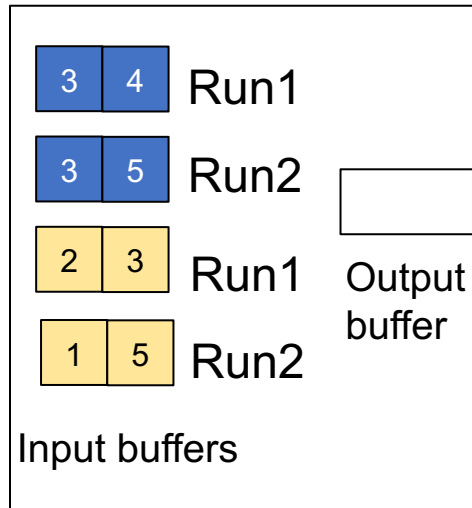

Step 2: Join while merging

Output tuples

- (1,1)
- (1,1)
- (1,1)
- (1,1)
- (2,2)
- (2,2)
- (3,3)
- (3,3)
- ...

Merge-Join

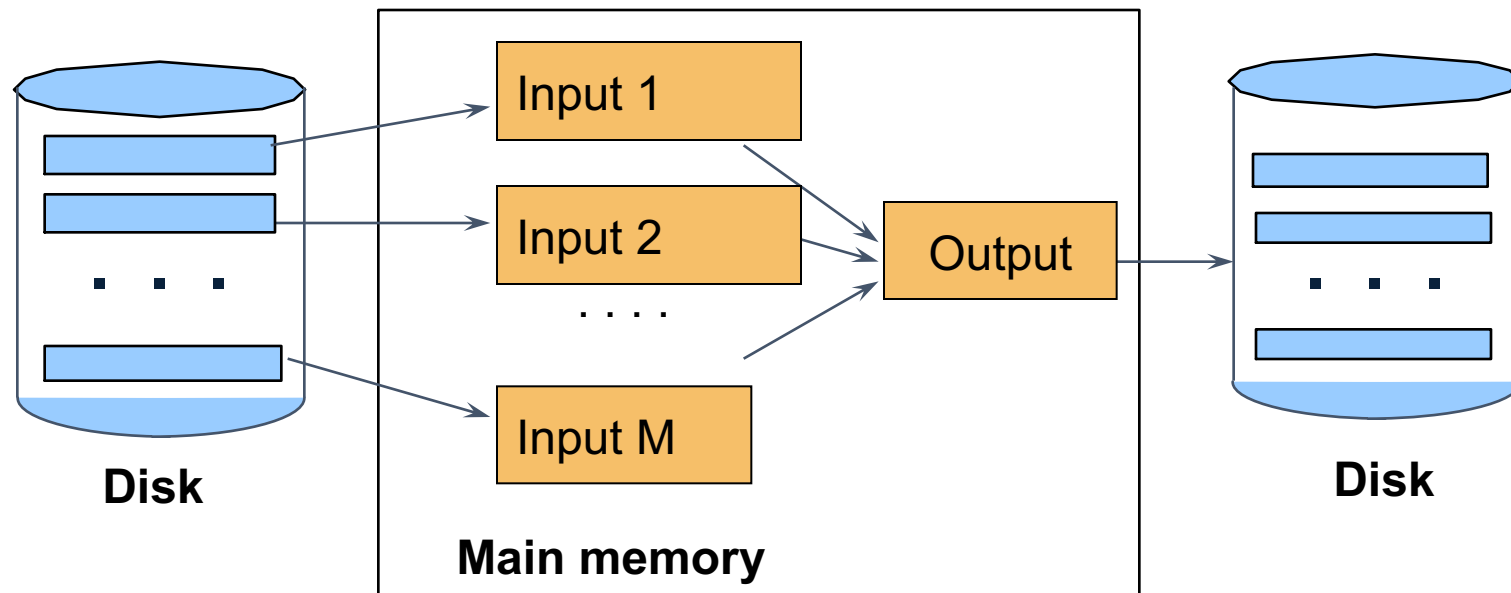

$M_1 = B(R)/M$ runs for R

$M_2 = B(S)/M$ runs for S

Merge-join $M_1 + M_2$ runs;

need $M_1 + M_2 \leq M$ to process all runs

i.e. $B(R) + B(S) \leq M^2$

$B(R)/M \leq M$