

# Database System Internals

## Query Optimization (part 2)

Paul G. Allen School of Computer Science and Engineering  
University of Washington, Seattle

# Announcements

HW 2 due today, late deadline Wednesday

HW 3 out tonight: Query Optimization

Afterwards we cover transactions in class and the next lab!

# Where We Are

Three components:

- Cost/cardinality estimation
- Search space
  - Algebraic laws
  - Restricting the query plans ← ...finishing this
- Search algorithm ← then we'll discuss this

# Two Types of Plan Enumeration Algorithms

- Dynamic programming (in class)
  - Based on System R (aka Selinger) style optimizer[1979]
  - Limited to joins: *join reordering algorithm*
  - Bottom-up
- Rule-based algorithm (will not discuss)
  - Database of rules (=algebraic laws)
  - Usually: dynamic programming
  - Usually: top-down

# Two Types of Optimizers

- **Rule-based (heuristic) optimizers:**
  - Apply greedily rules that always improve plan
    - Typically: push selections down
  - Very limited: no longer used today
- **Cost-based optimizers:**
  - Use a cost model to estimate the cost of each plan
  - Select the “cheapest” plan
  - We focus on cost-based optimizers

# Three Approaches to Search Space

- Complete plans
- Bottom-up plans
- Top-down plans

# Complete Plans

R(A,B)  
S(B,C)  
T(C,D)

```
SELECT *  
FROM R, S, T  
WHERE R.B=S.B and S.C=T.C and R.A<40
```

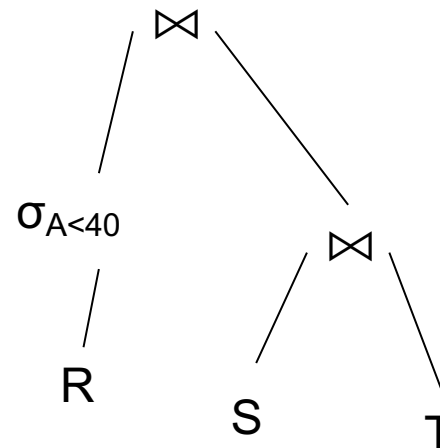
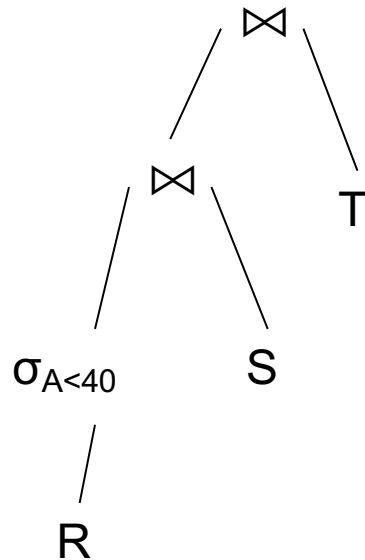

Why is this search space inefficient ?

Answer: No way to do early pruning

# Top-down Partial Plans

R(A,B)  
S(B,C)  
T(C,D)

```
SELECT *  
FROM R, S, T  
WHERE R.B=S.B and S.C=T.C and R.A<40
```

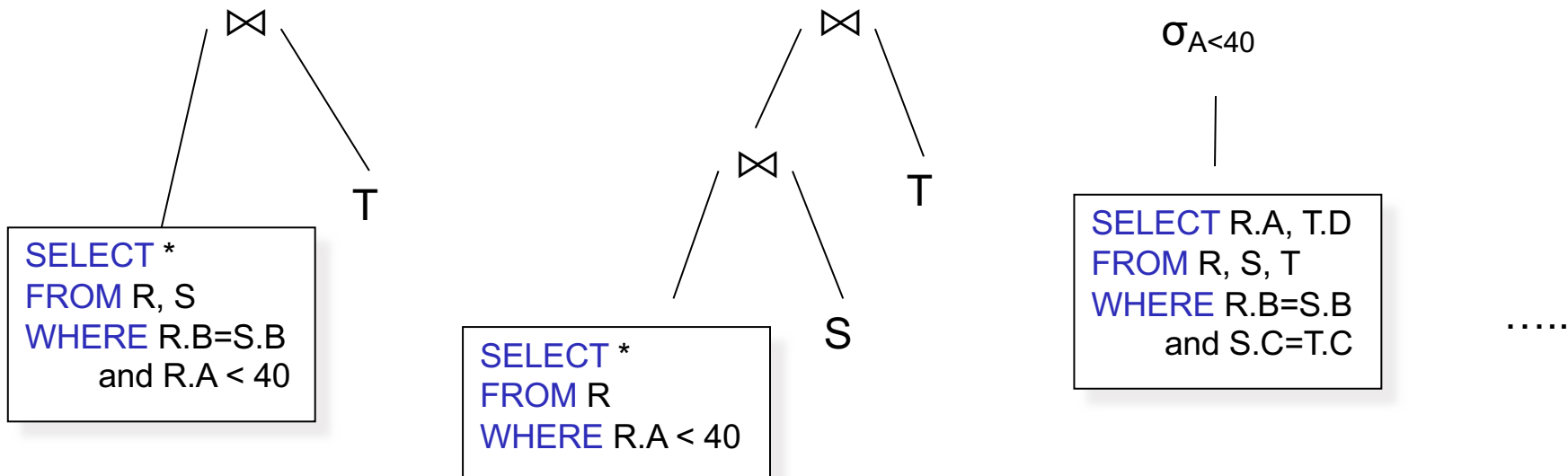

# Bottom-up Partial Plans

R(A,B)  
S(B,C)  
T(C,D)

```
SELECT *  
FROM R, S, T  
WHERE R.B=S.B and S.C=T.C and R.A<40
```

Why is this better ?

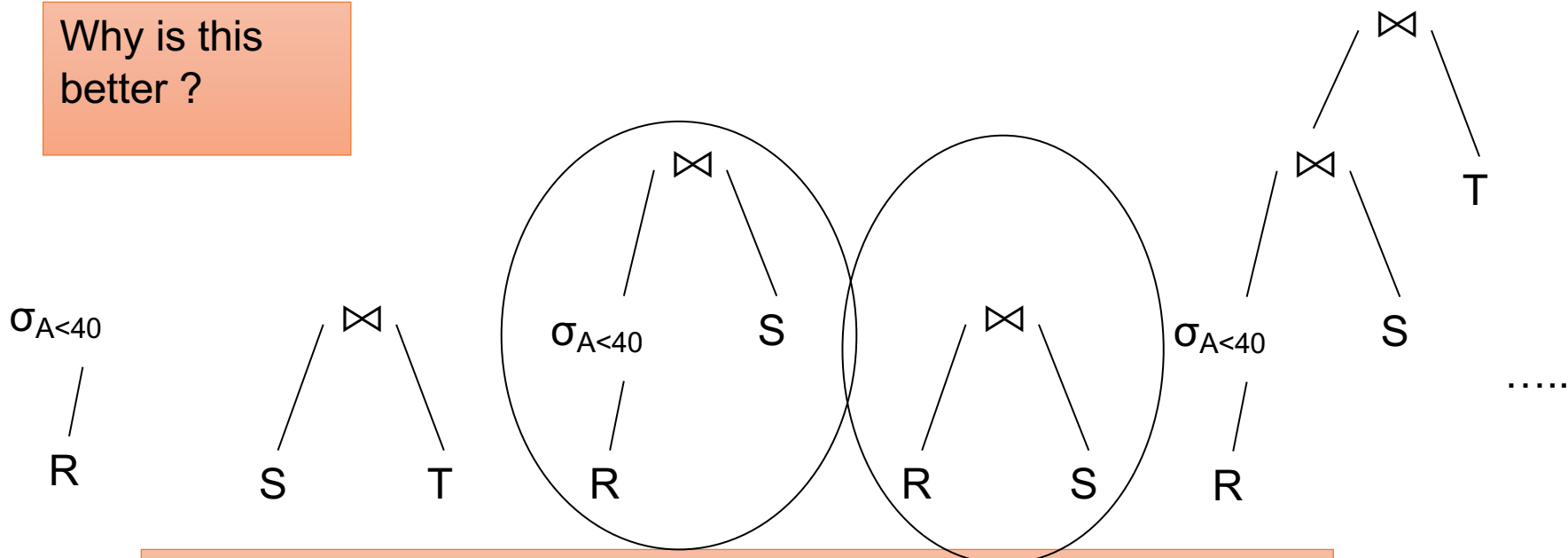

We will prune bad plans for sub-expressions

# Query Optimizer Overview

- **Input:** A logical query plan
- **Output:** A good physical query plan
- **Basic query optimization algorithm**
  - Enumerate alternative plans (logical and physical)
  - Compute estimated cost of each plan
    - Compute number of I/Os
    - Optionally take into account other resources
  - Choose plan with lowest cost
  - This is called cost-based optimization

# Search Algorithm

- Dynamic programming (in class)
  - Based on System R (aka Selinger) style optimizer[1979]
  - Limited to joins: *join reordering algorithm*
  - Bottom-up
- Rule-based algorithm (will not discuss)
  - Database of rules (=algebraic laws)
  - Usually: dynamic programming
  - Usually: top-down

# Dynamic Programming

Originally proposed in System R [1979]

- Only handles single block queries:

```
SELECT list  
FROM R1, ..., Rn  
WHERE cond1 AND cond2 AND . . . AND condk
```

- Some heuristics for search space enumeration:
  - Selections down
  - Projections up
  - Avoid cartesian products

# Dynamic Programming

```
SELECT list  
FROM R1, ..., Rn  
WHERE cond1 AND cond2 AND . . . AND condk
```

- For each subquery  $Q \subseteq \{R_1, \dots, R_n\}$  compute the following:
  - $T(Q)$  = the estimated size of  $Q$
  - $\text{Plan}(Q)$  = a best plan for  $Q$
  - $\text{Cost}(Q)$  = the estimated cost of that plan

# Dynamic Programming

```
SELECT list  
FROM R1, ..., Rn  
WHERE cond1 AND cond2 AND . . . AND condk
```

- **Step 1:** For each  $\{R_i\}$  do:
  - $T(\{R_i\}) = T(R_i)$
  - $\text{Plan}(\{R_i\}) =$  access method for  $R_i$
  - $\text{Cost}(\{R_i\}) =$  cost of access method for  $R_i$

- **Step 2:** For each  $Q \subseteq \{R_1, \dots, R_n\}$  of size  $k$  do:
  - $T(Q)$  = use estimator
  - Consider all partitions  $Q = Q' \cup Q''$   
compute  $\text{cost}(\text{Plan}(Q') \bowtie \text{Plan}(Q''))$
  - $\text{Cost}(Q)$  = the smallest such cost
  - $\text{Plan}(Q)$  = the corresponding plan
  
- **Note**
  - If we restrict to left-linear trees:  $Q''$  = single relation
  - May want to avoid cartesian products

```
SELECT list  
FROM R1, ..., Rn  
WHERE cond1 AND cond2 AND . . . AND condk
```

- **Step 3:** Return Plan( $\{R_1, \dots, R_n\}$ )

# Example

```
SELECT *  
FROM R, S, T, U  
WHERE cond1 AND cond2 AND . . .
```

- $R \bowtie S \bowtie T \bowtie U$
- Assumptions:

```
T(R) = 2000  
T(S) = 5000  
T(T) = 3000  
T(U) = 1000
```

- Every join selectivity is 0.001

# Example

$T(R) = 2000$   
 $T(S) = 5000$   
 $T(T) = 3000$   
 $T(U) = 1000$

Assume  
 $B(..) = T(..)/10$

Join selectivity  
is 0.001

Subquery	T	Plan	Cost
R	2000		
S	5000		
T	3000		
U	1000		
RS			
RT			
RU			
ST			
SU			
TU			
RST			
RSU			
RTU			
STU			
RSTU			

# Example

$T(R) = 2000$   
 $T(S) = 5000$   
 $T(T) = 3000$   
 $T(U) = 1000$

Assume  
 $B(..) = T(..)/10$

Join selectivity  
is 0.001

Subquery	T	Plan	Cost
R	2000		
S	5000		
T	3000		
U	1000		
RS	10000		
RT	6000		
RU	2000		
ST	15000		
SU	5000		
TU	3000		
RST	30000		
RSU	10000		
RTU	6000		
STU	15000		
RSTU	30000		

# Example

$T(R) = 2000$   
 $T(S) = 5000$   
 $T(T) = 3000$   
 $T(U) = 1000$

Assume  
 $B(..) = T(..)/10$

Join selectivity  
 is 0.001

Subquery	T	Plan	Cost
R	2000	Clustered index scan R.A	200
S	5000		
T	3000		
U	1000		
RS	10000		
RT	6000		
RU	2000		
ST	15000		
SU	5000		
TU	3000		
RST	30000		
RSU	10000		
RTU	6000		
STU	15000		
RSTU	30000		

# Example

$T(R) = 2000$   
 $T(S) = 5000$   
 $T(T) = 3000$   
 $T(U) = 1000$

Assume  
 $B(..) = T(..)/10$

Join selectivity  
is 0.001

Subquery	T	Plan	Cost
R	2000	Clustered index scan R.A	200
S	5000	Table scan	500
T	3000		
U	1000		
RS	10000		
RT	6000		
RU	2000		
ST	15000		
SU	5000		
TU	3000		
RST	30000		
RSU	10000		
RTU	6000		
STU	15000		
RSTU	30000		

# Example

$T(R) = 2000$   
 $T(S) = 5000$   
 $T(T) = 3000$   
 $T(U) = 1000$

Assume  
 $B(..) = T(..)/10$

Join selectivity  
 is 0.001

Subquery	T	Plan	Cost
R	2000	Clustered index scan R.A	200
S	5000	Table scan	500
T	3000	Table scan	300
U	1000	Clustered index scan U.F	100
RS	10000		
RT	6000		
RU	2000		
ST	15000		
SU	5000		
TU	3000		
RST	30000		
RSU	10000		
RTU	6000		
STU	15000		
RSTU	30000		

# Example

$T(R) = 2000$   
 $T(S) = 5000$   
 $T(T) = 3000$   
 $T(U) = 1000$

Assume  
 $B(..) = T(..)/10$

Join selectivity  
 is 0.001

Subquery	T	Plan	Cost
R	2000	Clustered index scan R.A	200
S	5000	Table scan	500
T	3000	Table scan	300
U	1000	Clustered index scan U.F	100
RS	10000	$R \bowtie S$ nested loop join	...
RT	6000		
RU	2000		
ST	15000		
SU	5000		
TU	3000		
RST	30000		
RSU	10000		
RTU	6000		
STU	15000		
RSTU	30000		

# Example

$T(R) = 2000$   
 $T(S) = 5000$   
 $T(T) = 3000$   
 $T(U) = 1000$

Assume  
 $B(..) = T(..)/10$

Join selectivity  
 is 0.001

Subquery	T	Plan	Cost
R	2000	Clustered index scan R.A	200
S	5000	Table scan	500
T	3000	Table scan	300
U	1000	Clustered index scan U.F	100
RS	10000	R $\bowtie$ S nested loop join	...
RT	6000	R $\bowtie$ T index join	...
RU	2000		
ST	15000		
SU	5000		
TU	3000		
RST	30000		
RSU	10000		
RTU	6000		
STU	15000		
RSTU	30000		

# Example

$T(R) = 2000$   
 $T(S) = 5000$   
 $T(T) = 3000$   
 $T(U) = 1000$

Assume  
 $B(..) = T(..)/10$

Join selectivity  
 is 0.001

Subquery	T	Plan	Cost
R	2000	Clustered index scan R.A	200
S	5000	Table scan	500
T	3000	Table scan	300
U	1000	Clustered index scan U.F	100
RS	10000	R ⋈ S nested loop join	...
RT	6000	R ⋈ T index join	...
RU	2000	R ⋈ U index join	
ST	15000	S ⋈ T hash join	
SU	5000	...	
TU	3000	...	
RST	30000		
RSU	10000		
RTU	6000		
STU	15000		
RSTU	30000		

# Example

$T(R) = 2000$   
 $T(S) = 5000$   
 $T(T) = 3000$   
 $T(U) = 1000$

Assume  
 $B(..) = T(..)/10$

Join selectivity  
 is 0.001

Subquery	T	Plan	Cost
R	2000	Clustered index scan R.A	200
S	5000	Table scan	500
T	3000	Table scan	300
U	1000	Clustered index scan U.F	100
RS	10000	$R \bowtie S$ nested loop join	...
RT	6000	$R \bowtie T$ index join	...
RU	2000	$R \bowtie U$ index join	
ST	15000	$S \bowtie T$ hash join	
SU	5000	...	
TU	3000	...	
RST	30000	$(RT) \bowtie S$ hash join	...
RSU	10000	$(SU) \bowtie R$ merge join	
RTU	6000	...	
STU	15000		
RSTU	30000		

# Example

$T(R) = 2000$   
 $T(S) = 5000$   
 $T(T) = 3000$   
 $T(U) = 1000$

Assume  
 $B(..) = T(..)/10$

Join selectivity  
 is 0.001

Subquery	T	Plan	Cost
R	2000	Clustered index scan R.A	200
S	5000	Table scan	500
T	3000	Table scan	300
U	1000	Clustered index scan U.F	100
RS	10000	R $\bowtie$ S nested loop join	...
RT	6000	R $\bowtie$ T index join	...
RU	2000	R $\bowtie$ U index join	
ST	15000	S $\bowtie$ T hash join	
SU	5000	...	
TU	3000	...	
RST	30000	(RT) $\bowtie$ S hash join	...
RSU	10000	(SU) $\bowtie$ R merge join	
RTU	6000	...	
STU	15000		
RSTU	30000	(RT) $\bowtie$ (SU) hash join	...

# Discussion

- For the subset  $\{RS\}$ , need to consider both  $R \bowtie S$  and  $S \bowtie R$ 
  - Because the cost may be different!
- When computing the cheapest plan for  $(Q) \bowtie R$ , we may consider new access methods for  $R$ , e.g. an index look-up that makes sense only in the context of the join

# Discussion

```
SELECT list  
FROM R1, ..., Rn  
WHERE cond1 AND cond2 AND . . . AND condk
```

Given a query with  $n$  relations  $R_1, \dots, R_n$

- How many entries do we have in the dynamic programming table?
- For each entry, how many alternative plans do we need to inspect?

# Discussion

```
SELECT list  
FROM R1, ..., Rn  
WHERE cond1 AND cond2 AND . . . AND condk
```

Given a query with  $n$  relations  $R_1, \dots, R_n$

- How many entries do we have in the dynamic programming table?
  - A:  $2^n - 1$
- For each entry, how many alternative plans do we need to inspect?
  - A: for each entry with  $k$  tables, examine  $2^k - 2$  plans

# Reducing the Search Space

- Left-linear trees
- No cartesian products

# Join Trees

- $R_1 \bowtie R_2 \bowtie \dots \bowtie R_n$
- Join tree:

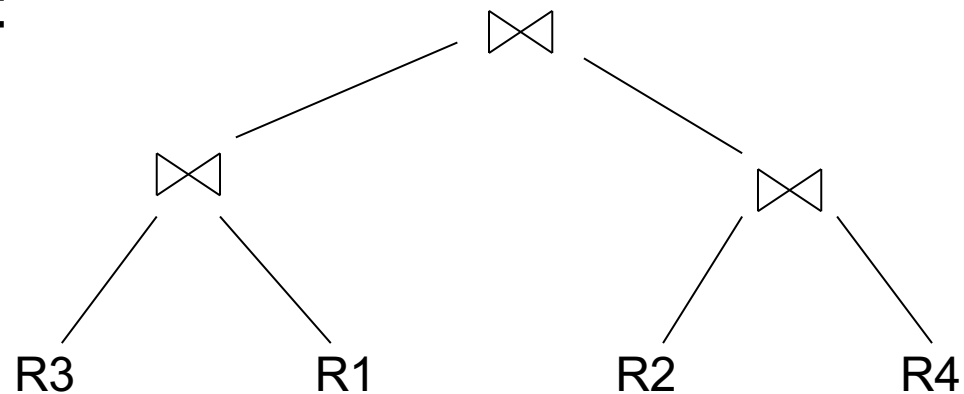

- A plan = a join tree
- A partial plan = a subtree of a join tree

# Types of Join Trees

- Bushy:

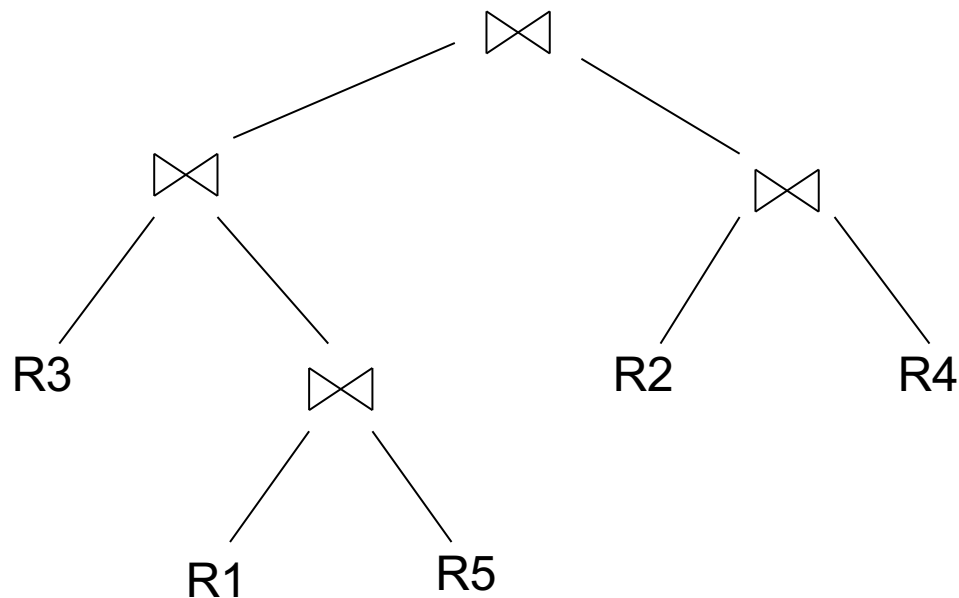

# Types of Join Trees

- Linear :

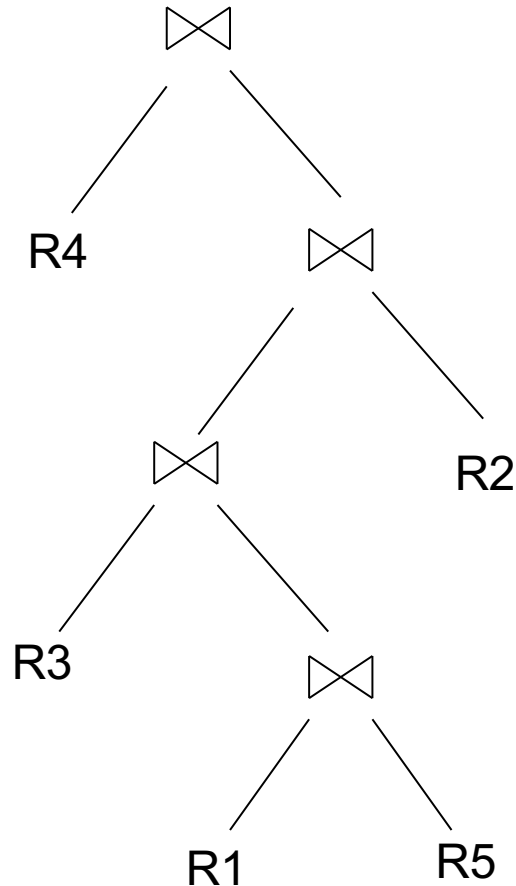

# Types of Join Trees

- Right deep:

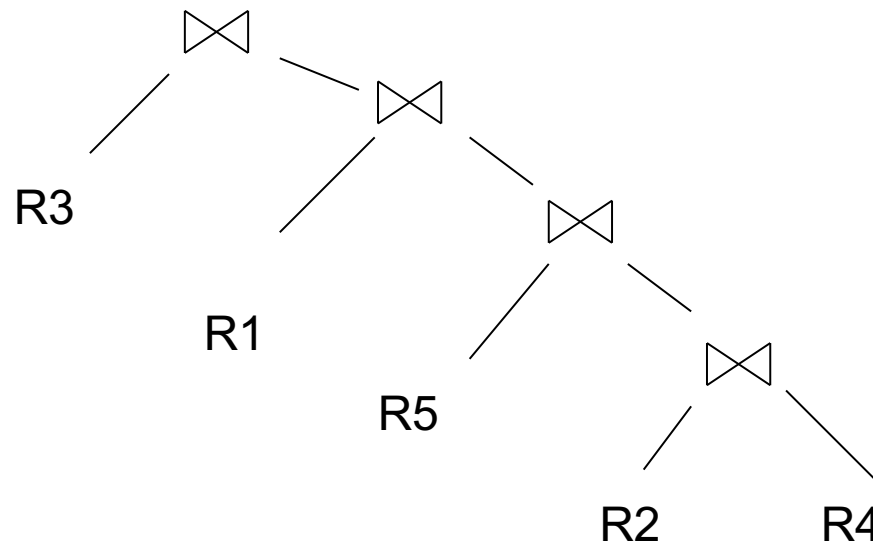

# Types of Join Trees

- Left deep:

- Work well with existing join algos
  - Nested-loop and hash-join
- Facilitate pipelining

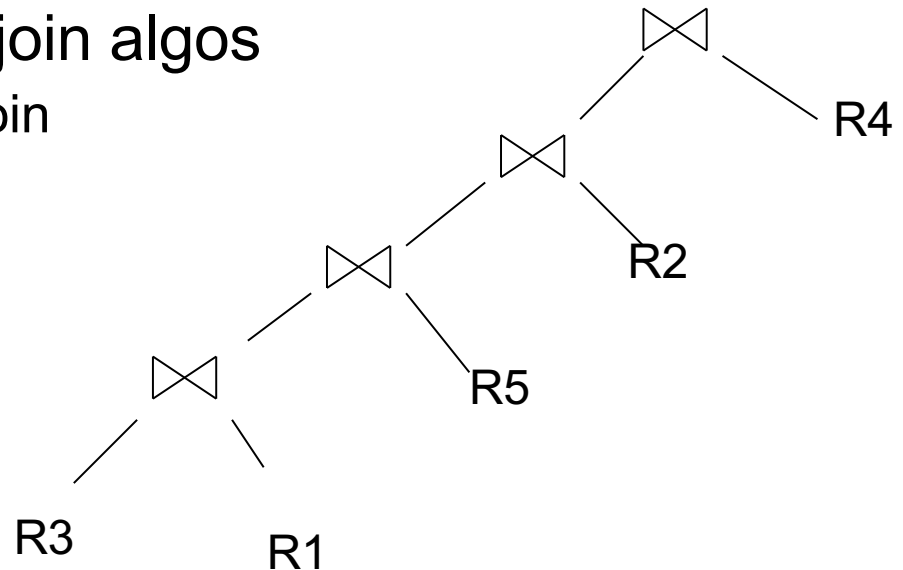

- Dynamic programming can be used with all trees

# No Cartesian Products

$$R(A,B) \bowtie S(B,C) \bowtie T(C,D)$$

Plan:  $(R(A,B) \bowtie T(C,D)) \bowtie S(B,C)$

has a cartesian product.

Most query optimizers will not consider it

# Avoid Cartesian Products

Supplier(sid, name, discount, city)  
Supply(sid, pno)  
Part(pno, pname, price)

```
select *  
from Supplier x, Supply y, Part z  
where x.sid = y.sid and y.pno = z.pno  
and x.city='Seattle' and z.price=100;
```

# Avoid Cartesian Products

Supplier(sid, name, discount, city)  
Supply(sid, pno)  
Part(pno, pname, price)

```
select *  
from Supplier x, Supply y, Part z  
where x.sid = y.sid and y.pno = z.pno  
and x.city='Seattle' and z.price=100;
```

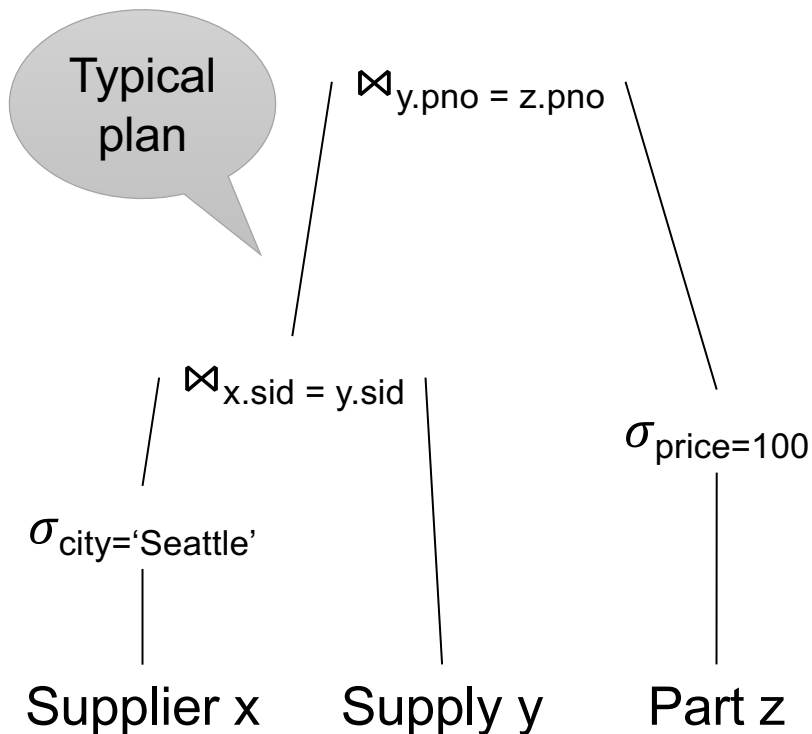

# Avoid Cartesian Products

Supplier(sid, name, discount, city)  
Supply(sid, pno)  
Part(pno, pname, price)

```
select *  
from Supplier x, Supply y, Part z  
where x.sid = y.sid and y.pno = z.pno  
and x.city='Seattle' and z.price=100;
```

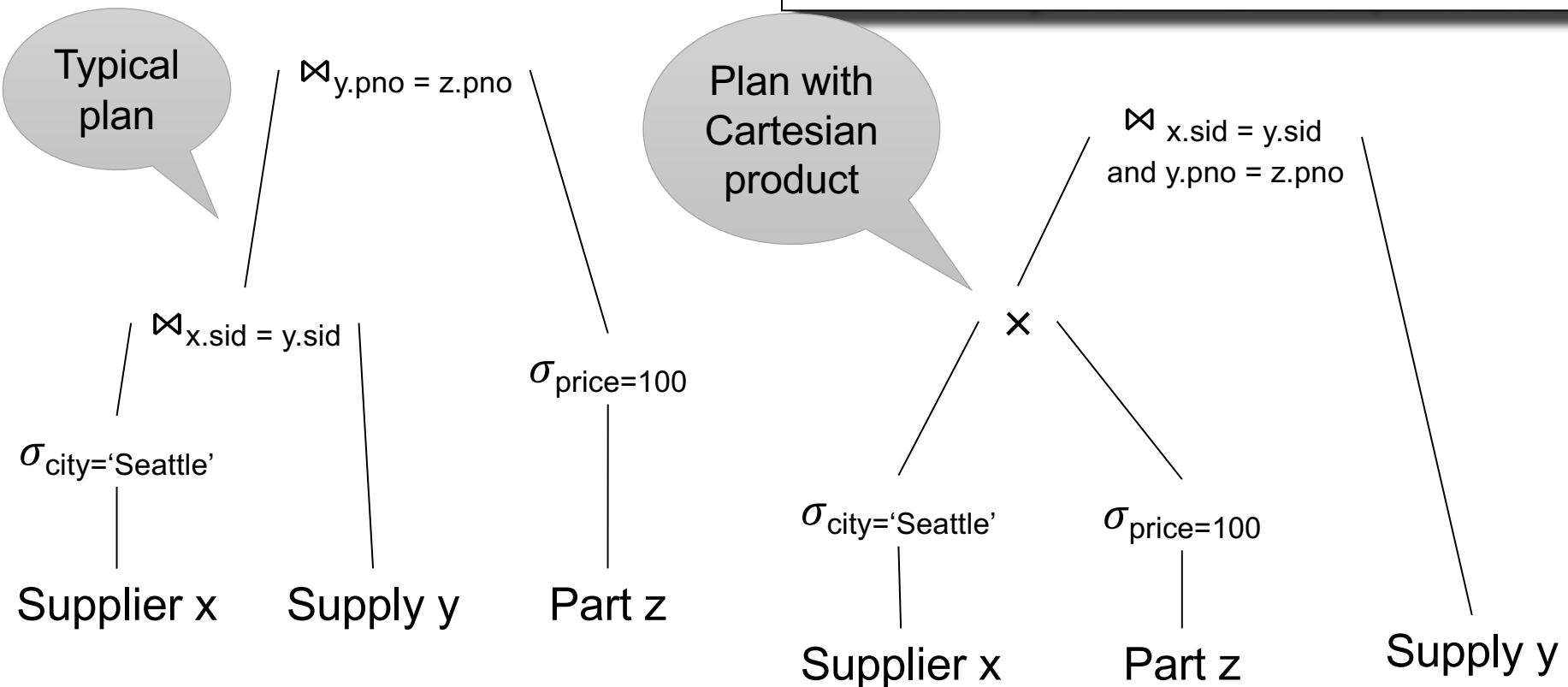

Most optimizers will not consider this plan