

Five Problems

CSE 421

Richard Anderson

Autumn 2016, Lecture 3

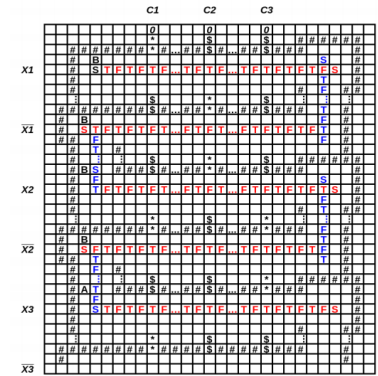

Announcements

Lecture Schedule, CSE 421, Autumn 2016

| Lecture | Date | Topic | Reading | Lecturer | Slides |
|-----------|-------------------------|--------------------------------------|-------------------------------|------------------|---|
| Lecture 1 | Wednesday, September 28 | Course Introduction, Stable Marriage | Kleinberg-Tardos, Section 1.1 | Richard Anderson | (PPTX) (PDF) (PDF Handouts) (HTML with iuk) |
| Lecture 2 | Friday, September 30 | Stable Matching | Kleinberg-Tardos, Section 1.1 | Richard Anderson | (PPTX) (PDF) (PDF Handouts) (HTML with iuk) |
| Lecture 3 | Monday, October 3 | Five Problems | Kleinberg-Tardos, Section 1.2 | Richard Anderson | |

- Course website

[//courses.cs.washington.edu/courses/cse421/16au/](http://courses.cs.washington.edu/courses/cse421/16au/)

- Office hours
 - Richard Anderson
 - Monday, 2:30 pm - 3:30 pm, CSE 582
 - Wednesday, 2:30 pm - 3:30 pm, CSE 582
 - Deepali Aneja
 - Monday, 5:30 pm - 6:30 pm, CSE 220
 - Max Horton
 - Monday, 4:30 pm – 5:30 pm, CSE 220
 - Tuesday, 2:00 pm – 3:00 pm, CSE 218
 - Ben Jones
 - Tuesday, 1:00 pm – 2:00 pm, CSE 218
 - Friday, 2:30 pm – 3:30 pm, CSE 220

Theory of Algorithms

- What is expertise?
- How do experts differ from novices?

Introduction of five problems

- Show the types of problems we will be considering in the class
- Examples of important types of problems
- Similar looking problems with very different characteristics
- Problems
 - Scheduling
 - Weighted Scheduling
 - Bipartite Matching
 - Maximum Independent Set
 - Competitive Facility Location

What is a problem?

- Instance
- Solution
- Constraints on solution
- Measure of value

Problem: Scheduling

- Suppose that you own a banquet hall
- You have a series of requests for use of the hall:
 $(s_1, f_1), (s_2, f_2), \dots$

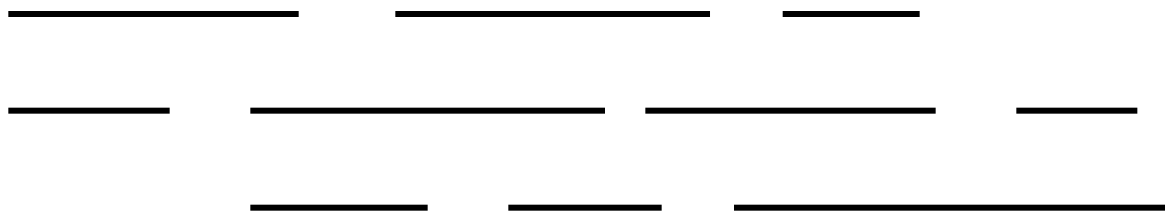

- Find a set of requests as large as possible with no overlap

What is the largest solution?

Greedy Algorithm

- Test elements one at a time if they can be members of the solution
- If an element is not ruled out by earlier choices, add it to the solution
- Many possible choices for ordering (length, start time, end time)
- For this problem, considering the jobs by increasing end time works

Suppose we add values?

- (s_i, f_i, v_i) , start time, finish time, payment
- Maximize value of elements in the solution

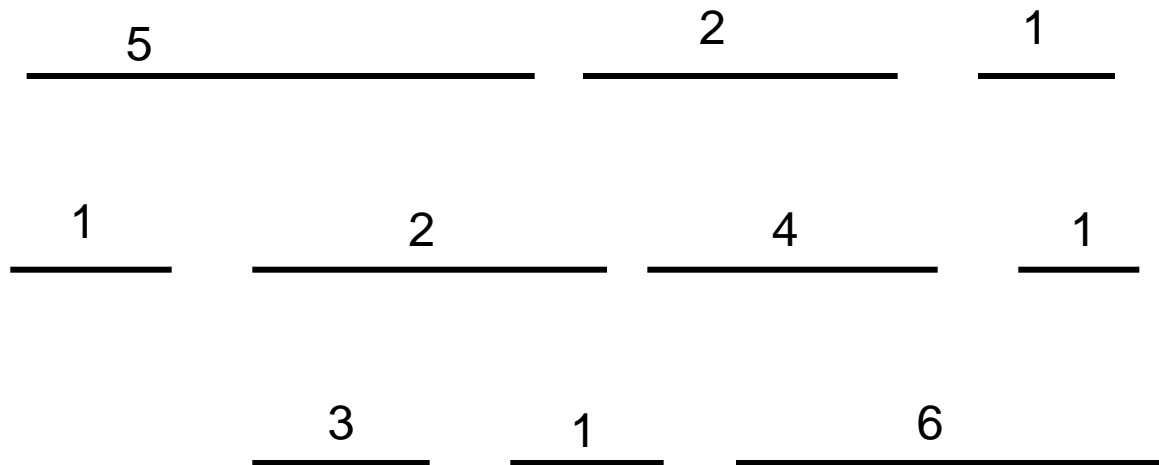

Greedy Algorithms

- Earliest finish time
- Maximum value
- Give counter examples to show these algorithms don't find the maximum value solution

Dynamic Programming

- Requests R_1, R_2, R_3, \dots
- Assume requests are in increasing order of finish time ($f_1 < f_2 < f_3 \dots$)
- Opt_i is the maximum value solution of $\{R_1, R_2, \dots, R_i\}$ containing R_i
- $Opt_i = \text{Max}\{ j \mid f_j < s_i \}[Opt_j + v_i]$

Matching

- Given a bipartite graph $G=(U,V,E)$, find a subset of the edges M of maximum size with no common endpoints.
- Application:
 - U : Professors
 - V : Courses
 - (u,v) in E if Prof. u can teach course v

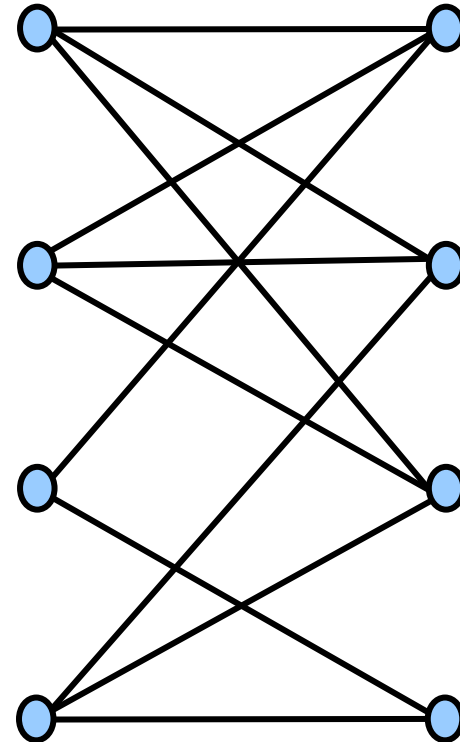

Find a maximum matching

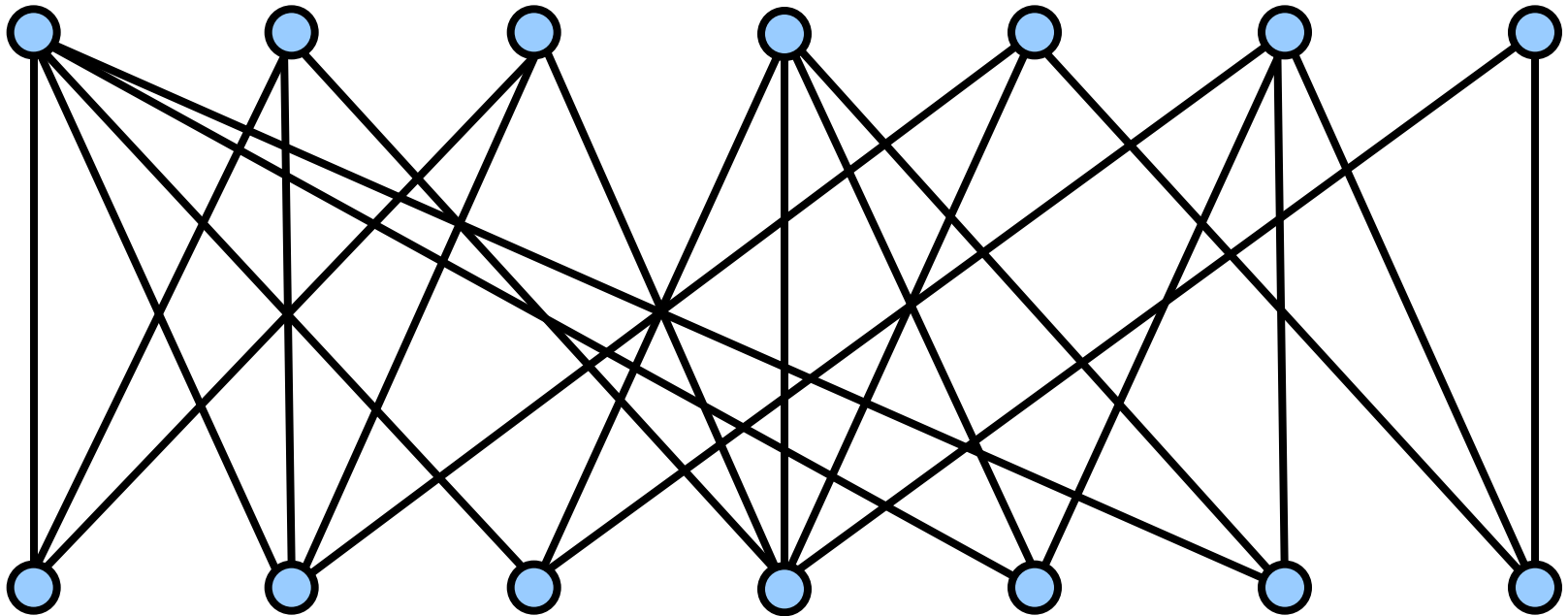

Augmenting Path Algorithm

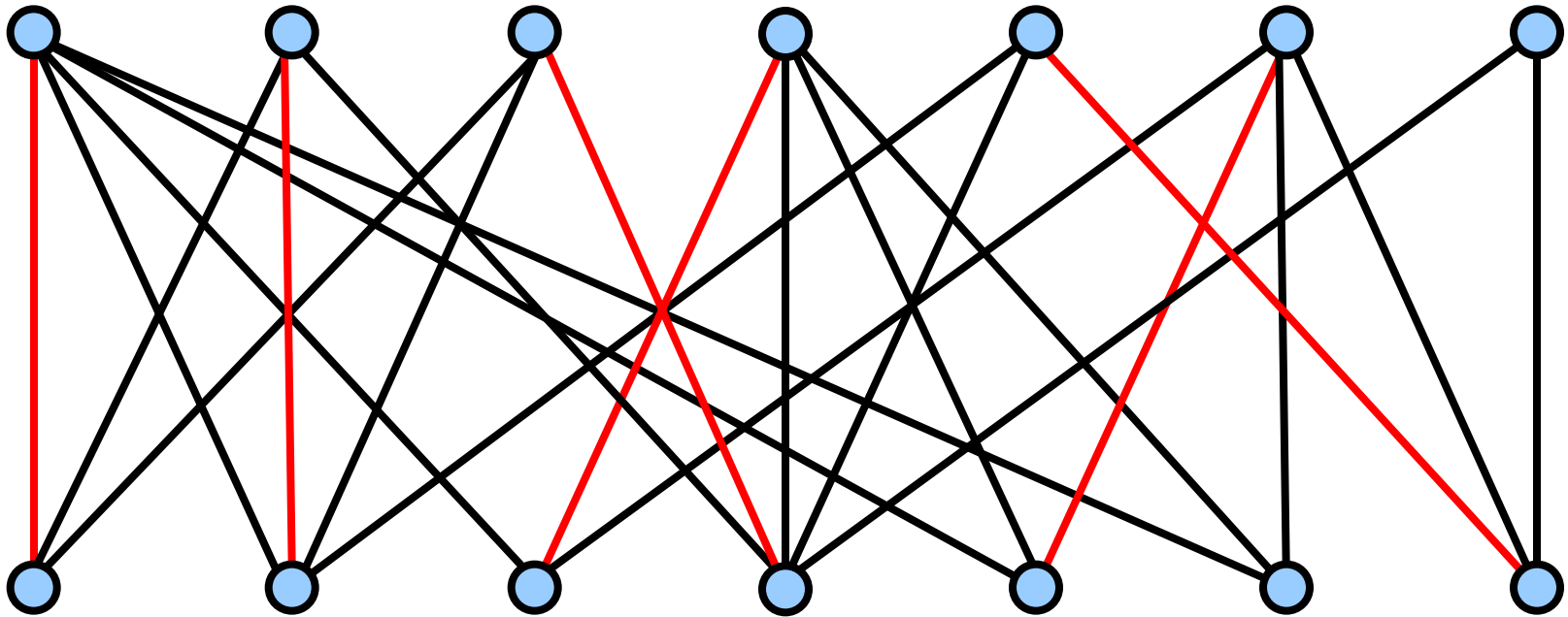

Reduction to network flow

- More general problem
- Send flow from source to sink
- Flow subject to capacities at edges
- Flow conserved at vertices
- Can solve matching as a flow problem

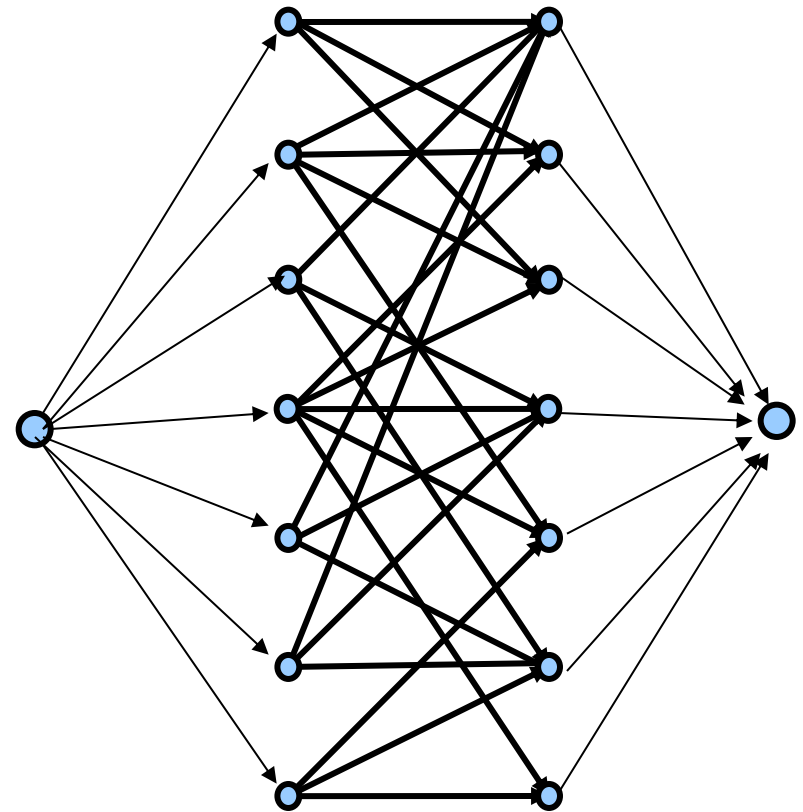

Maximum Independent Set

- Given an undirected graph $G=(V,E)$, find a set I of vertices such that there are no edges between vertices of I
- Find a set I as large as possible

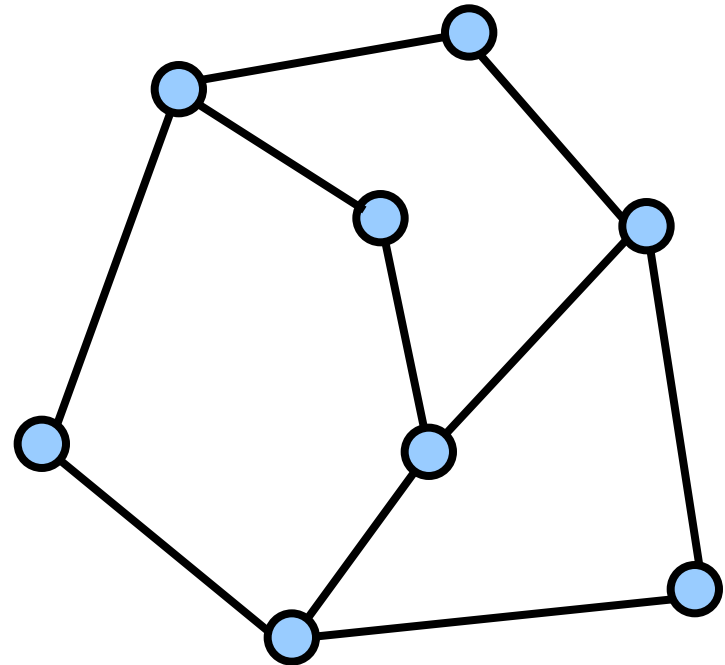

Find a Maximum Independent Set

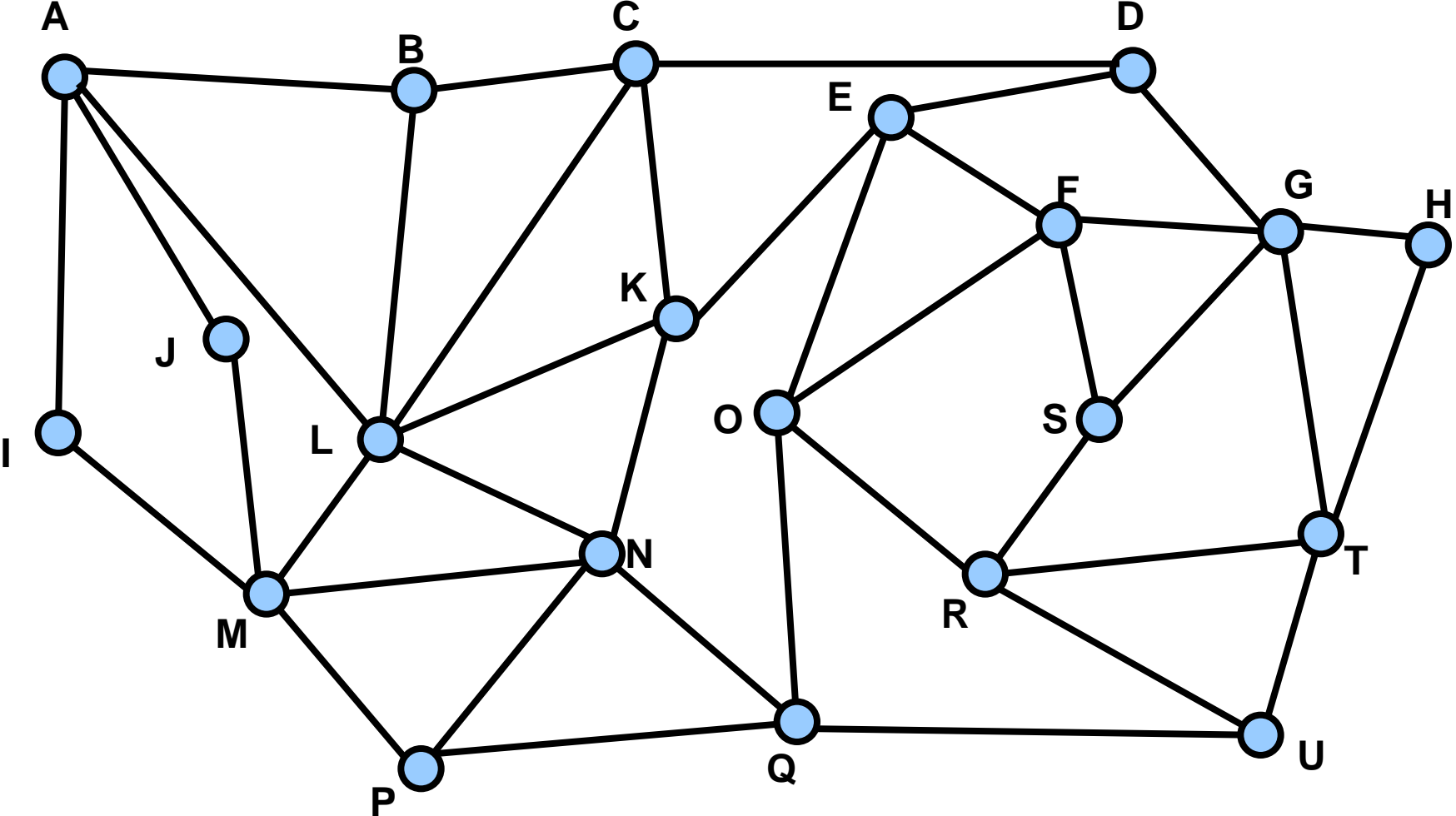

Key characteristic

- Hard to find a solution
- Easy to verify a solution once you have one
- Other problems like this
 - Hamiltonian circuit
 - Clique
 - Subset sum
 - Graph coloring

NP-Completeness

- Theory of Hard Problems
- A large number of problems are known to be equivalent
- Very elegant theory

Are there even harder problems?

- Simple game:
 - Players alternating selecting nodes in a graph
 - Score points associated with node
 - Remove nodes neighbors
 - When neither can move, player with most points wins

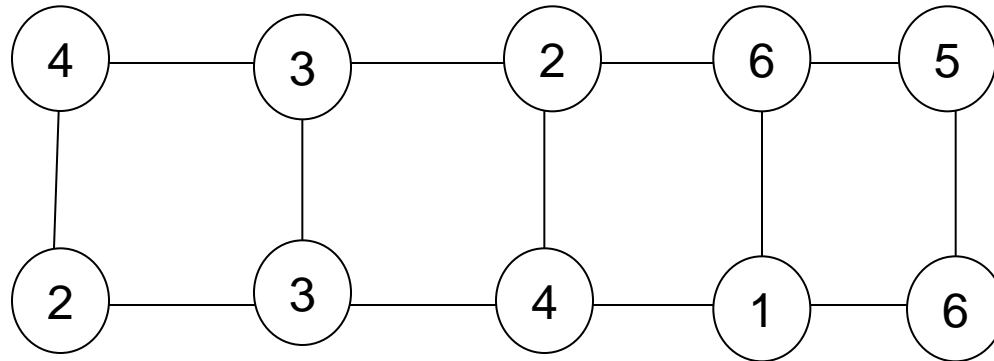

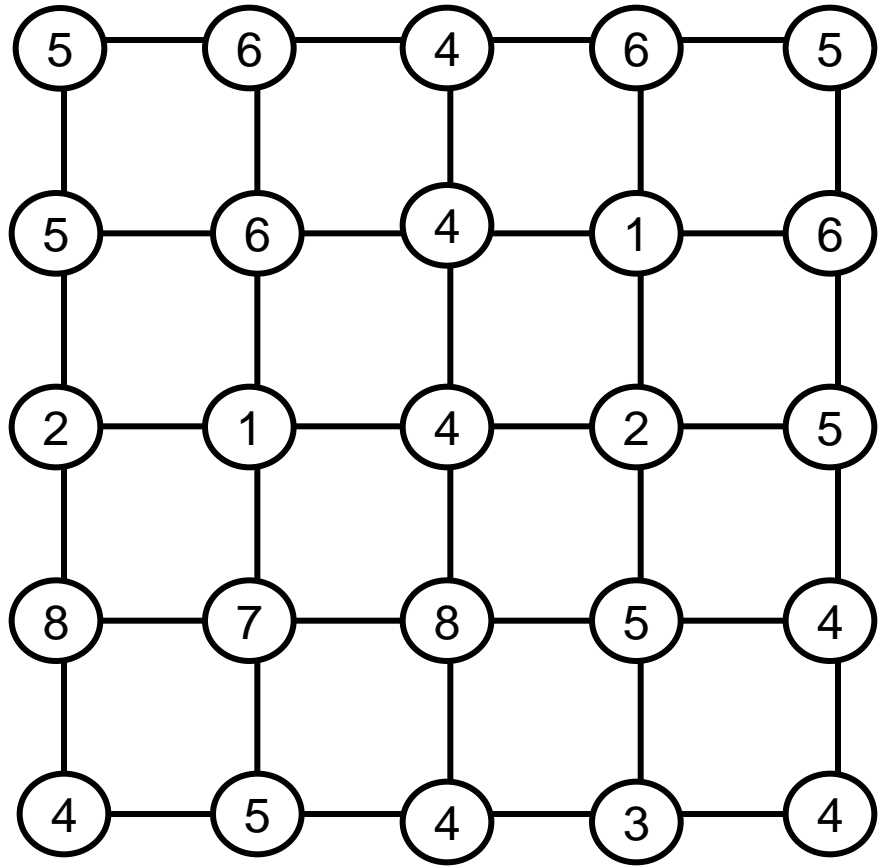

Competitive Facility Location

- Choose location for a facility
 - Value associated with placement
 - Restriction on placing facilities too close together
- Competitive
 - Different companies place facilities
 - E.g., KFC and McDonald's

Complexity theory

- These problems are P-Space complete instead of NP-Complete
 - Appear to be much harder
 - No obvious certificate
 - G has a Maximum Independent Set of size 10
 - Player 1 wins by at least 10 points

Summary

- Scheduling
- Weighted Scheduling
- Bipartite Matching
- Maximum Independent Set
- Competitive Scheduling