

CSE 401/M501 – Compilers

Languages, Automata, Regular Expressions
& Scanners

Hal Perkins

Autumn 2020

Administrivia

- Read: textbook ch. 1 and sec. 2.1-2.4
- First homework out by end of week, due next Thur.
 - Written problems on regexps/DFAs
 - We'll cover most everything needed on Thur. & Fri.
 - You'll email from gradescope when accounts are set up – submit hw1 there.
- Office hours on Canvas calander
- If you haven't already, pick a project partner
 - We'll post a form for ONE of you to send in partner info by the beginning of next week (worth 1 point for both of you *if* done right). Watch for email.

More Administrivia (added Fri. 10/2)

- HW1 assigned today. Due next Thursday, 11 pm. See links on the course calendars.
- Gradescope accounts were created earlier today for written hw turnin (hw1). You should get email at your UW mailing address
- Project partner information form posted before class and linked on the calendar) Please submit by 11 pm Tuesday night
- Send email to cse401-staff if any logistics things need fixing (gradescope accounts, ...)

Agenda

- Quick review of basic concepts of formal grammars
- Regular expressions
- Lexical specification of programming languages
- Using finite automata to recognize regular expressions
- Scanners and Tokens

Programming Language Specs

- Since the 1960s, the syntax of every significant programming language has been specified by a formal grammar
 - First done in 1959 with BNF (Backus-Naur Form), used to specify ALGOL 60 syntax
 - Borrowed from the linguistics community (Chomsky)

Formal Languages & Automata Theory

(a review on one slide)

- Alphabet: a finite set of symbols and characters
- String: a finite, possibly empty sequence of symbols from an alphabet
- Language: a set of strings (possibly empty or infinite)
- Finite specifications of (possibly infinite) languages
 - Automaton – a recognizer; a machine that accepts all strings in a language (and rejects all other strings)
 - Grammar – a generator; a system for producing all strings in the language (and no other strings)
- A particular language may be specified by many different grammars and automata
- A grammar or automaton specifies only one language

Language (Chomsky) hierarchy: quick reminder

- Regular (Type-3) languages are specified by regular expressions/grammars and finite automata (FSAs)
 - Specs and implementation of scanners
- Context-free (Type-2) languages are specified by context-free grammars and pushdown automata (PDAs)
 - Specs and implementation of parsers
- Context-sensitive (Type-1) languages ... aren't too important (at least for us)
- Recursively-enumerable (Type-0) languages are specified by general grammars and Turing machines

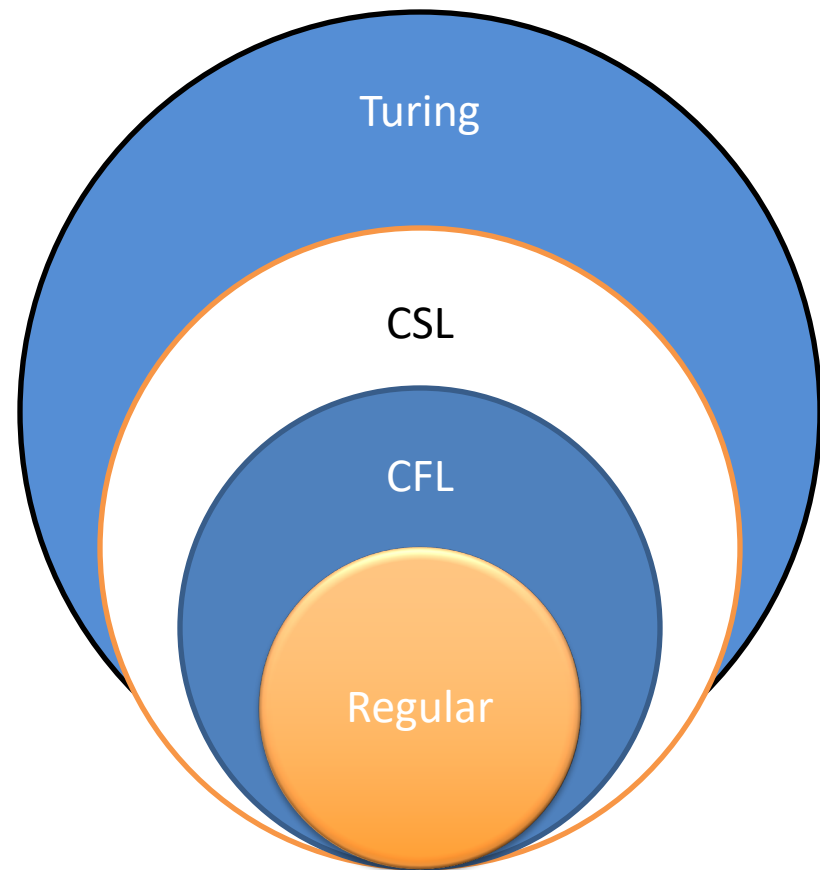

Example:

Grammar for a Tiny Language

program ::= statement | program statement

statement ::= assignStmt | ifStmt

assignStmt ::= id = expr ;

ifStmt ::= if (expr) statement

expr ::= id | int | expr + expr

id ::= a | b | c | i | j | k | n | x | y | z

int ::= 0 | 1 | 2 | 3 | 4 | 5 | 6 | 7 | 8 | 9

Exercise: Derive a simple program

```
program ::= statement | program statement  
statement ::= assignStmt | ifStmt  
assignStmt ::= id = expr ;  
ifStmt ::= if ( expr ) statement  
expr ::= id | int | expr + expr  
id ::= a | b | c | i | j | k | n | x | y | z  
int ::= 0 | 1 | 2 | 3 | 4 | 5 | 6 | 7 | 8 | 9
```

a = 1 ; if (a + 1) b = 2 ;

Exercise: Derive a simple program

```
program ::= statement | program statement
statement ::= assignStmt | ifStmt
assignStmt ::= id = expr ;
ifStmt ::= if ( expr ) statement
expr ::= id | int | expr + expr
id ::= a | b | c | i | j | k | n | x | y | z
int ::= 0 | 1 | 2 | 3 | 4 | 5 | 6 | 7 | 8 | 9
```

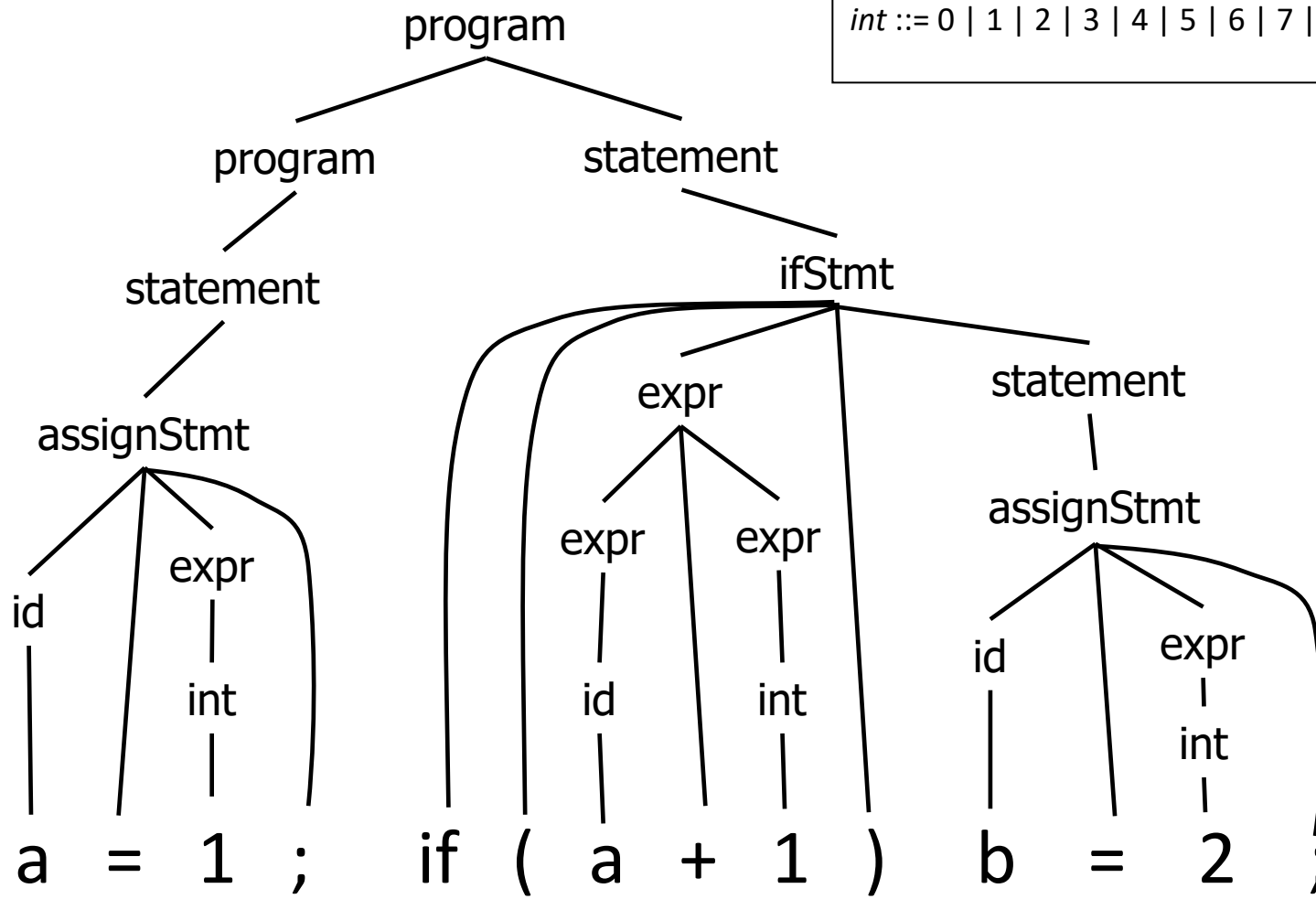

Productions

- The rules of a grammar are called productions
- Rules contain:
 - Nonterminal symbols: grammar variables (program, statement, id, etc.)
 - Terminal symbols: concrete syntax that appears in programs (a, b, c, 0, 1, if, =, (,), ...)
- Meaning of
nonterminal ::= <sequence of terminals and nonterminals>
is: in a derivation an instance of nonterminal can be replaced by the sequence of terminals and nonterminals on the right of the production
- Often there are several productions for a nonterminal – can choose any rule for nonterminal in different parts of derivation

Alternative Notations

- There are several notations for productions in common use; all mean the same thing

ifStmt ::= if (expr) statement

ifStmt → if (expr) statement

<ifStmt> ::= if (<expr>) <statement>

Parsing

- Parsing: reconstruct the derivation (syntactic structure) of a program
- In principle, a single recognizer could work directly from a concrete, character-by-character grammar
- In practice this is never done

Parsing & Scanning

- In real compilers the recognizer is split into two phases
 - Scanner: translate input characters to tokens
 - Also, report lexical errors like illegal characters and illegal symbols
 - Parser: read token stream and reconstruct the derivation

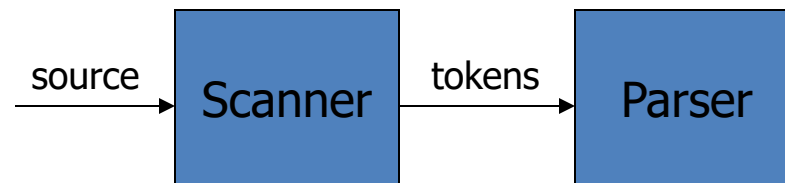

Why Separate the Scanner and Parser?

- **Simplicity & Separation of Concerns**
 - Scanner hides details from parser (comments, whitespace, input files, etc.)
 - Parser is easier to build; has simpler input stream (tokens) and simpler interface for input
- **Efficiency**
 - Scanner recognizes regular expressions – proper subset of context free grammars
 - (But still often consumes a surprising amount of the compiler's total execution time)

But ...

- Not always possible to separate cleanly
- Example: C/C++/Java *type vs identifier*
 - Parser would like to know which names are types and which are identifiers, but...
 - Scanner doesn't know how things are declared
- So we hack around it somehow...
 - Either use simpler grammar and disambiguate later, or communicate between scanner & parser
 - Engineering issue: try to keep interfaces as simple & clean as possible

Scanner Example

- Input text

```
// this statement does very little  
if (x >= y) y = 42;
```

- Token Stream

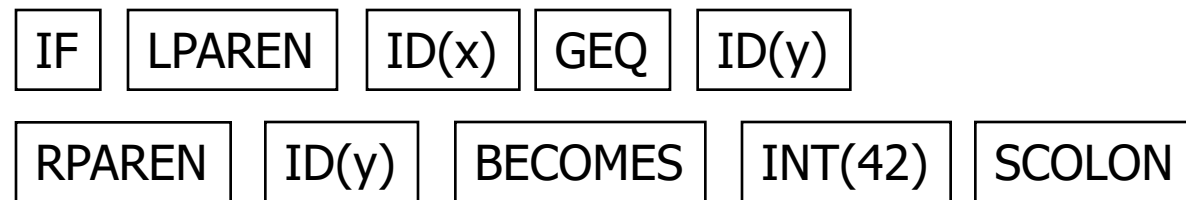

- Notes: tokens are atomic items, not character strings; comments & whitespace are *not* tokens (in most languages – counterexamples: Python indenting, Ruby and JavaScript newlines)
 - Token objects sometimes carry associated data (e.g., numeric value, variable name)

Typical Tokens in Programming Languages

- Operators & Punctuation
 - + - * / () { } [] ; : :: < <= == != ! ...
 - Each of these is a distinct lexical class
- Keywords
 - if while for goto return switch void ...
 - Each of these is also a distinct lexical class (*not* a string)
- Identifiers
 - A single ID lexical class, but parameterized by actual id
- Integer constants
 - A single INT lexical class, but parameterized by int value
- Other constants, etc.

Principle of Longest Match

- In most languages, the scanner should pick the longest possible string to make up the next token if there is a choice
- Example

return maybe != iffy;

should be recognized as 5 tokens

RETURN	ID(maybe)	NEQ	ID(iffy)	SCOLON
--------	-----------	-----	----------	--------

i.e., != is one token, not two; “iffy” is an ID, not IF followed by ID(fy)

Lexical Complications

- Most modern languages are free-form
 - Layout doesn't matter
 - Whitespace separates tokens
- Alternatives
 - Fortran – line oriented
 - Haskell, Python – indentation and layout can imply grouping
- And other confusions
 - In C++ or Java, is >> a shift operator or the end of two nested templates or generic classes?

Regular Expressions and FAs

- The lexical grammar (structure) of most programming languages can be specified with regular expressions
 - (Sometimes a little cheating is needed)
- Tokens can be recognized by a deterministic finite automaton
 - Can be either table-driven or built by hand based on lexical grammar

Regular Expressions

- Defined over some alphabet Σ
 - For programming languages, alphabet is usually ASCII or Unicode
- If re is a regular expression, $L(re)$ is the language (set of strings) generated by re

Fundamental REs

re	$L(re)$	Notes
a	$\{ a \}$	Singleton set, for each a in Σ
ε	$\{ \varepsilon \}$	Empty string
\emptyset	$\{ \}$	Empty language

Operations on REs

re	$L(re)$	Notes
rs	$L(r)L(s)$	Concatenation
$r s$	$L(r) \cup L(s)$	Combination (union)
r^*	$L(r)^*$	0 or more occurrences (Kleene closure)

- Precedence: * (highest), concatenation, | (lowest)
- Parentheses can be used to group REs as needed
- In “real” regular expression computer tools, need some way to “escape” literal ‘*’ or ‘|’ characters vs. operators – but don’t worry, or use different fonts, for math regexps.

Examples

<i>re</i>	Meaning
+	single + character
!	single ! character
=	single = character
!=	2 character sequence "!="
xyzyz	5 character sequence "xyzyz"
(1 0)*	0 or more binary digits
(1 0)(1 0)*	1 or more binary digits
0 1(0 1)*	sequence of binary digits with no leading 0's, except for 0 itself

Abbreviations

- The basic operations generate all possible regular expressions, but there are common abbreviations used for convenience. Some examples:

Abbr.	Meaning	Notes
r^+	(rr^*)	1 or more occurrences
$r?$	$(r \mid \epsilon)$	0 or 1 occurrence
$[a-z]$	$(a \mid b \mid \dots \mid z)$	1 character in given range
$[abxyz]$	$(a \mid b \mid x \mid y \mid z)$	1 of the given characters

More Examples

<i>re</i>	Meaning
[abc]+	
[abc]*	
[0-9]+	
[1-9][0-9]*	
[a-zA-Z][a-zA-Z0-9_]*	

More Examples

<i>re</i>	Meaning
[abc]+	Sequence of 1 or more a's, b's, c's
[abc]*	Sequence of 0 or more a's, b's, c's
[0-9]+	Sequence of 1 or more decimal digits
[1-9][0-9]*	Sequence of 1 or more decimal digits without a leading 0
[a-zA-Z][a-zA-Z0-9_]*	Identifiers in <i>Your Favorite Programming Language</i> TM

Abbreviations

- Many systems allow abbreviations to make writing and reading definitions or specifications easier

name ::= *re*

- Restriction: abbreviations must not be circular (recursive) either directly or indirectly (else would be non-regular)

Example

- Possible syntax for numeric constants

digit ::= [0-9]

digits ::= *digit*⁺

number ::= *digits* (. *digits*)?

([eE] (+ | -)? *digits*) ?

- How would you describe this set in English?
- What are some examples of legal constants (strings) generated by *number* ?
 - What are the differences between these and numeric constants in YFPL? (Your Favorite Programming Language)

Recognizing REs

- Finite automata can be used to recognize strings generated by regular expressions
- Can build by hand or automatically
 - Reasonably straightforward, and can be done systematically
 - Tools like Lex, Flex, JFlex et al do this automatically, given a set of REs
 - Same techniques used in grep, sed, other regular expression packages/tools

Finite State Automaton

(a review on one slide)

- A finite set of states
 - One marked as initial state
 - One or more marked as final states
 - States sometimes labeled or numbered
- A set of transitions from state to state
 - Each labeled with symbol from Σ , or ϵ
 - Common to allow multiple labels (symbols) on one edge to simplify diagrams
- Operate by reading input symbols (usually characters for scanners)
 - Transition can be taken if labeled with current symbol
 - ϵ -transition can be taken at any time
- Accept when final state reached & no more input
 - Slightly different in a scanner where the FSA is a subroutine that accepts the longest input string matching a token regular expression, starting at the current location in the input
- Reject if no transition possible, or no more input and not in final state (DFA)
 - Some versions (including textbook) have an explicit “error” state and transitions to it on all “no legal transition possible” input. OK to omit that for CSE 401

Example: FSA for “cat”

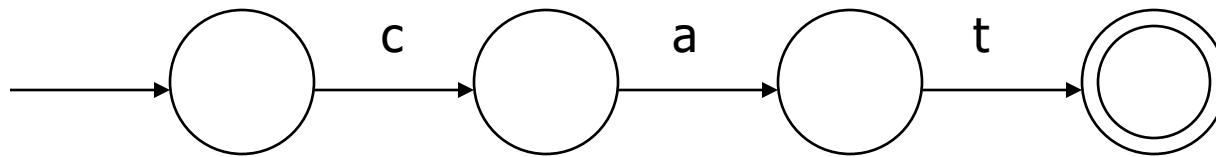

DFA vs NFA

- Deterministic Finite Automata (DFA)
 - No choice of which transition to take under any condition
 - No ϵ transitions (arcs)
- Non-deterministic Finite Automata (NFA)
 - Choice of transition in at least one case
 - Accept if some way to reach a final state on given input
 - Reject if no possible way to final state
 - i.e., may need to guess right path or backtrack

FAs in Scanners

- Want DFA for speed (no backtracking)
- But conversion from regular expressions to NFA is easy
- Fortunately, there is a well-defined procedure for converting a NFA to an equivalent DFA (subset construction)

From RE to NFA: base cases

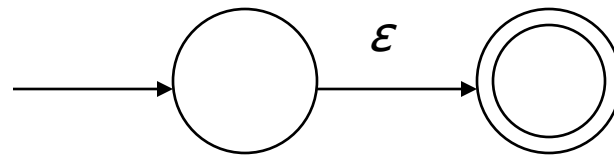
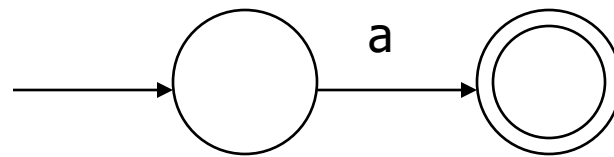

rs

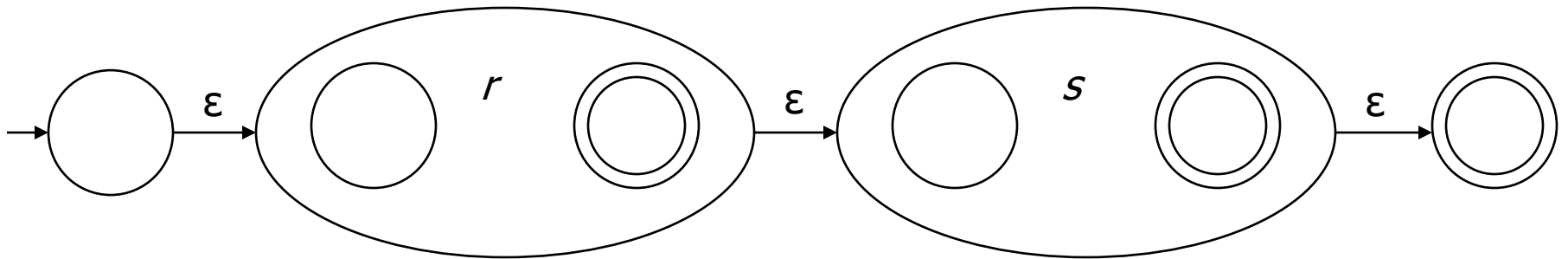

$r \mid s$

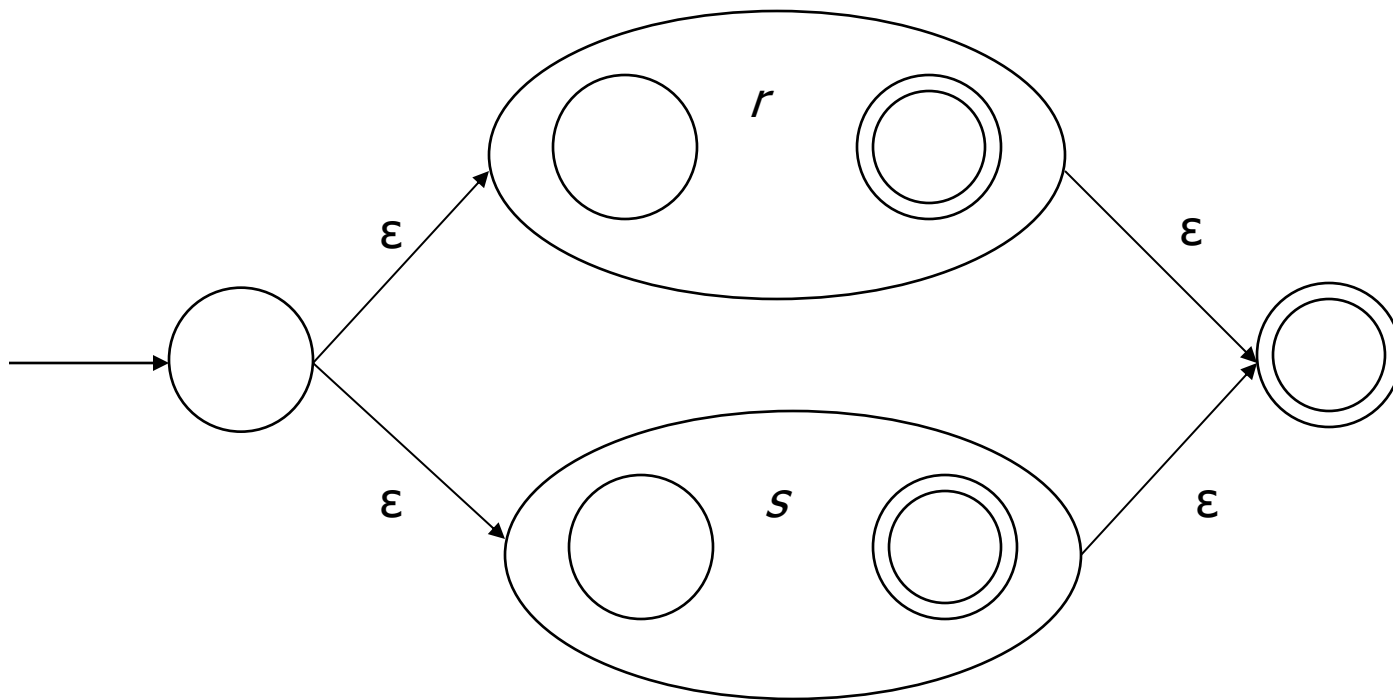

r^*

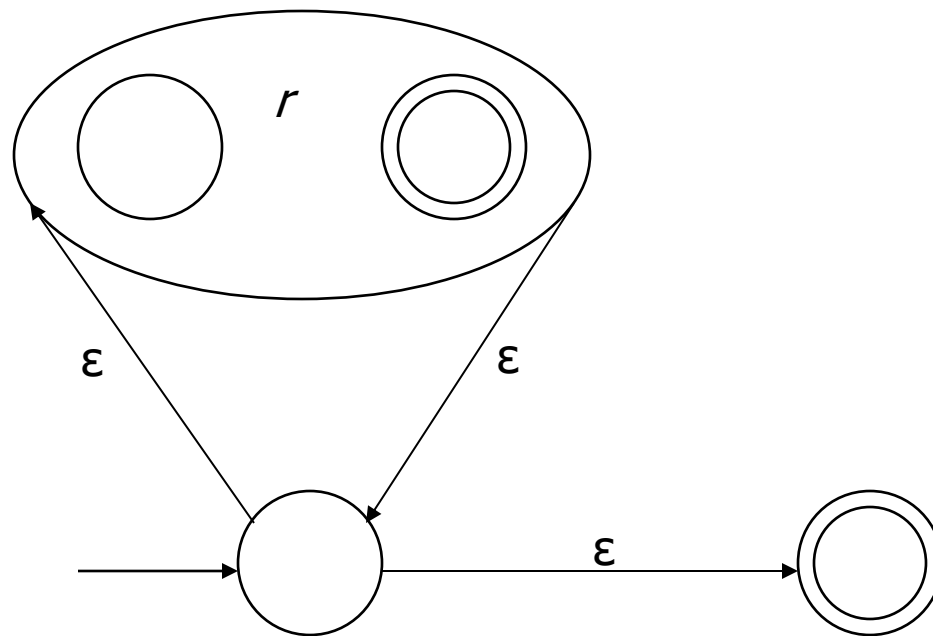

Exercise

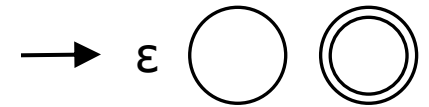

- Draw the NFA for: $b(at|ag) | bug$

Exercise

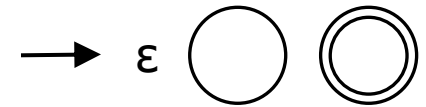

- Draw the NFA for: $b(at|ag) | bug$

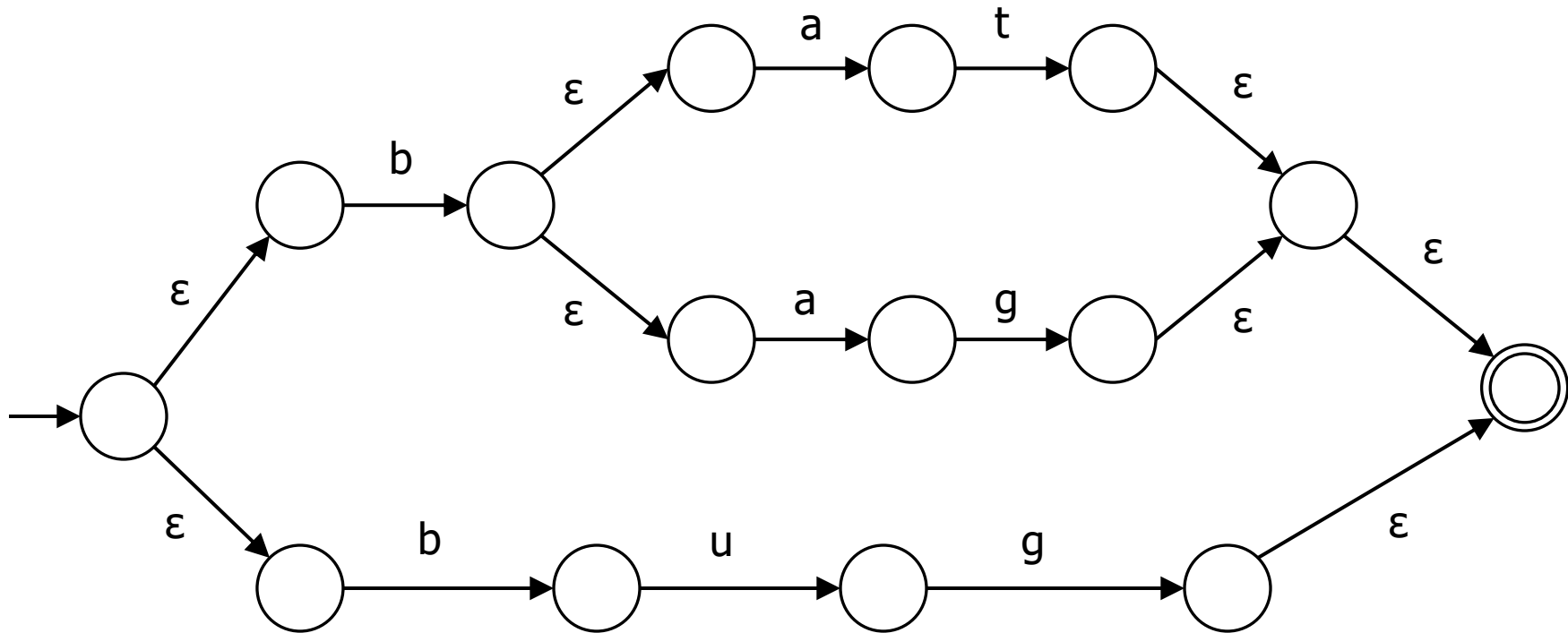

From NFA to DFA

- Subset construction
 - Construct a DFA from the NFA, where each DFA state represents a set of NFA states
- Key idea
 - State of the DFA after reading some input is the set of all NFA states that could be reached after reading the same input
- Algorithm: example of a fixed-point computation
- If NFA has n states, DFA has at most 2^n states
 - => DFA is finite, can construct in finite # steps
- Resulting DFA may have more states than needed
 - See books for construction and minimization details

Exercise

- Build DFA for $b(at|ag)|bug$, given the NFA

Exercise

- Build DFA for $b(at|ag)|bug$, given the NFA

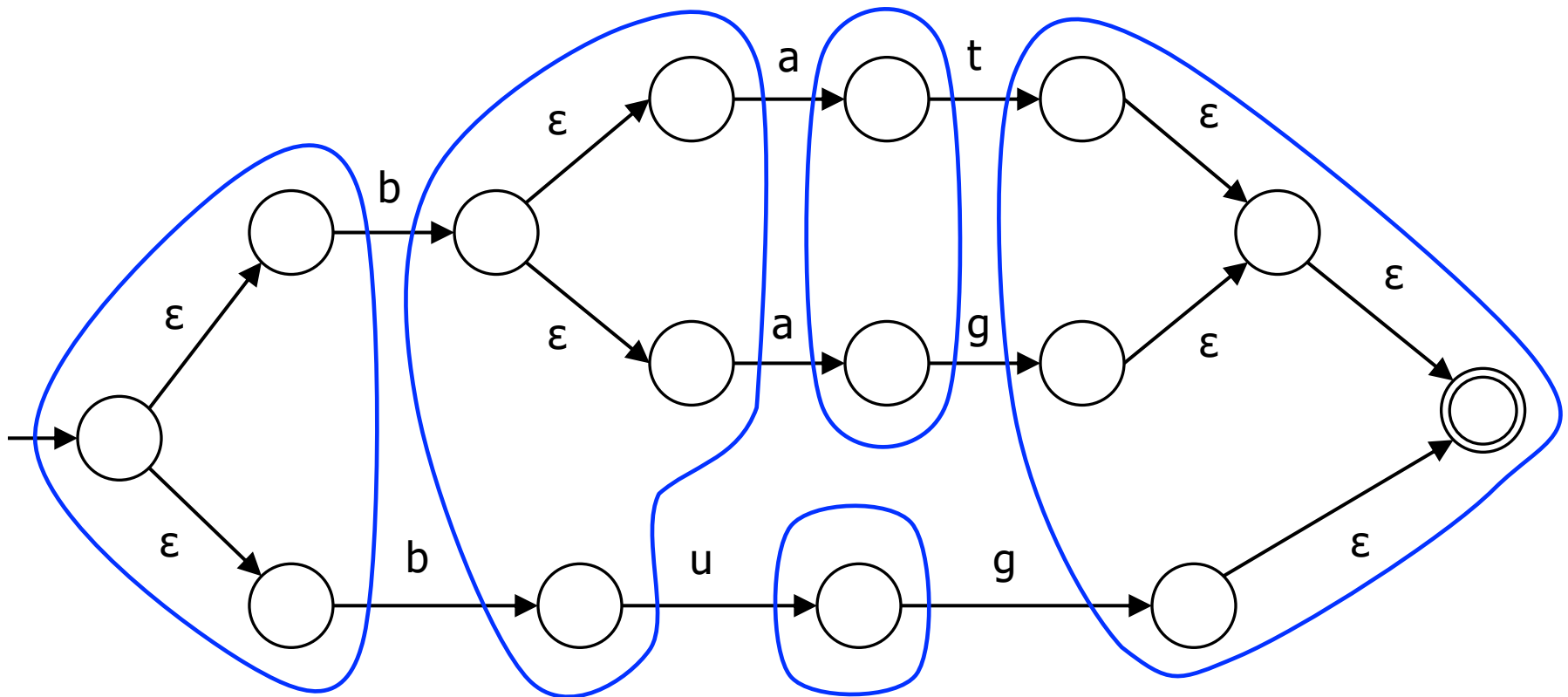

To Tokens

- A scanner is a DFA that finds the next token each time it is called
- Every “final” state of scanner DFA emits (returns) a token
- Tokens are the internal compiler names for the lexemes
 - == becomes EQUAL
 - (becomes LPAREN
 - while becomes WHILE
 - xyzy becomes ID(xyzy)
- You choose the names
- Also, there may be additional data ... \r\n might count lines; token data structure might include source line numbers

DFA => Code

- Option 1: Implement by hand using procedures
 - one procedure for each token
 - each procedure reads one character
 - choices implemented using if and switch statements
- Pros
 - straightforward to write
 - fast
- Cons
 - a lot of tedious work
 - may have subtle differences from the language specification

DFA => Code [continued]

- Option 1a: Like option 1, but structured as a single procedure with multiple return points
 - choices implemented using if and switch statements
- Pros
 - also straightforward to write
 - faster
- Cons
 - a lot of tedious work
 - may have subtle differences from the language specification

DFA => code [continued]

- Option 2: use tool to generate table driven scanner
 - Rows: states of DFA
 - Columns: input characters
 - Entries: action
 - Go to next state
 - Accept token, go to start state
 - Error
- Pros
 - Convenient
 - Exactly matches specification, if tool generated
- Cons
 - “Magic”

DFA => code [continued]

- Option 2a: use tool to generate scanner
 - Transitions embedded in the code
 - Choices use conditional statements, loops
- Pros
 - Convenient
 - Exactly matches specification, if tool generated
- Cons
 - “Magic”
 - Lots of code – big but potentially quite fast
 - Would never write something like this by hand, but can generate it easily enough

Example: DFA for hand-written scanner

- Idea: show a hand-written DFA for some typical programming language constructs
 - Then use to outline a hand-written scanner
- Setting: Scanner is called when the parser needs a new token
 - Scanner knows (saves) current position in input
 - From there, use a DFA to recognize the longest possible input sequence that makes up a token and return that token; save updated position for next time
- Disclaimer: Example for illustration only – you'll use tools for the course project
 - & we're abusing the DFA notation a little – not all arrows in the diagram correspond to consuming an input character, but meaning should be pretty obvious

Scanner DFA Example (1)

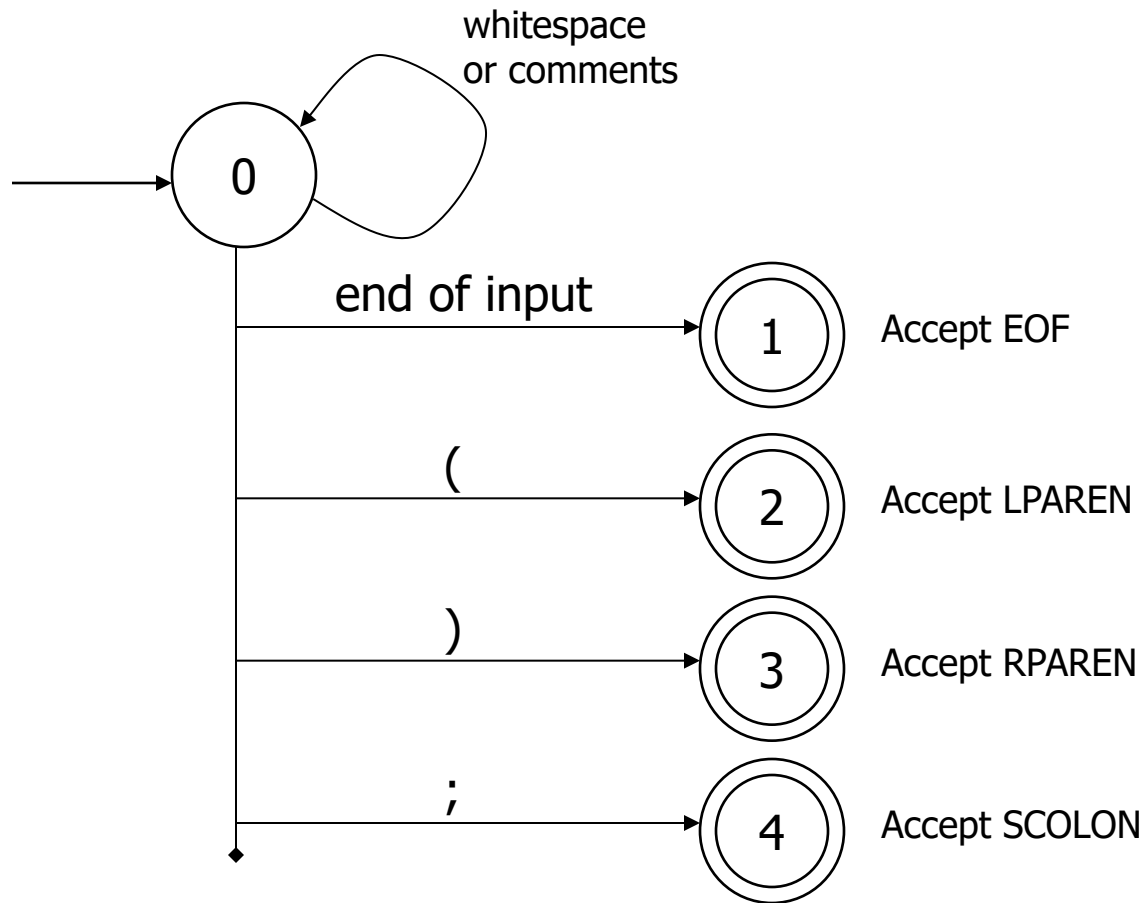

Scanner DFA Example (2)

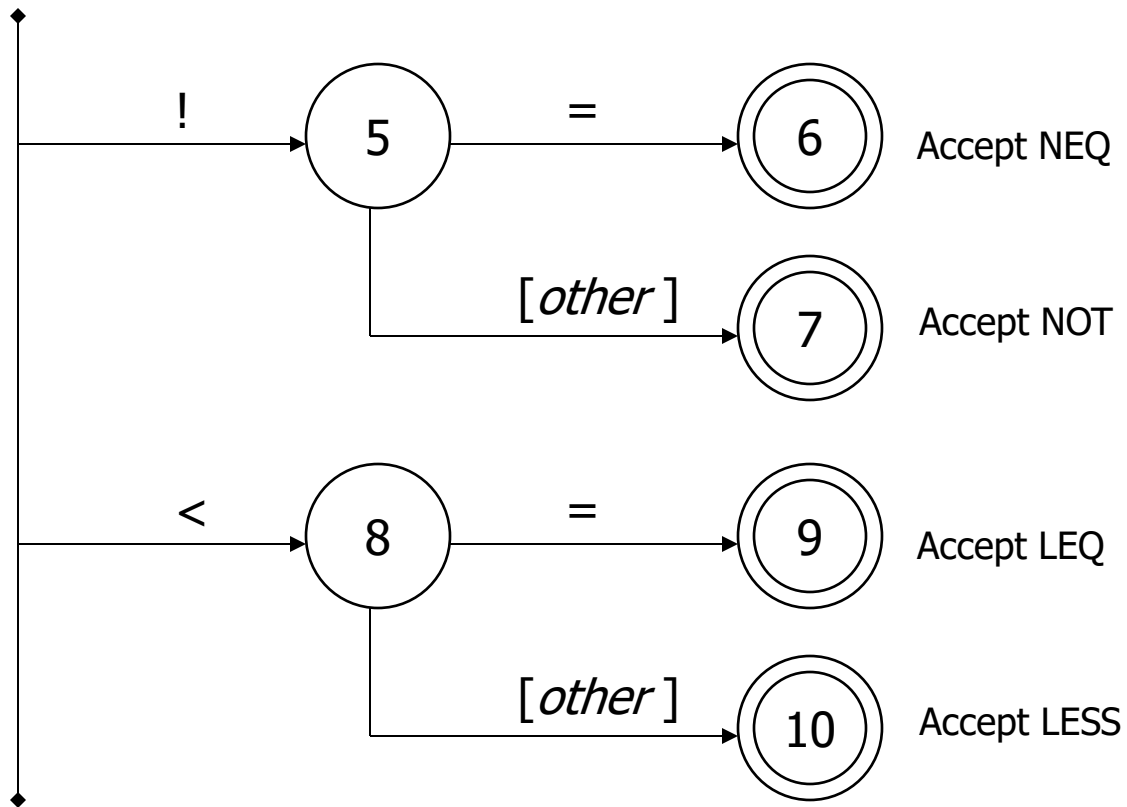

Scanner DFA Example (3)

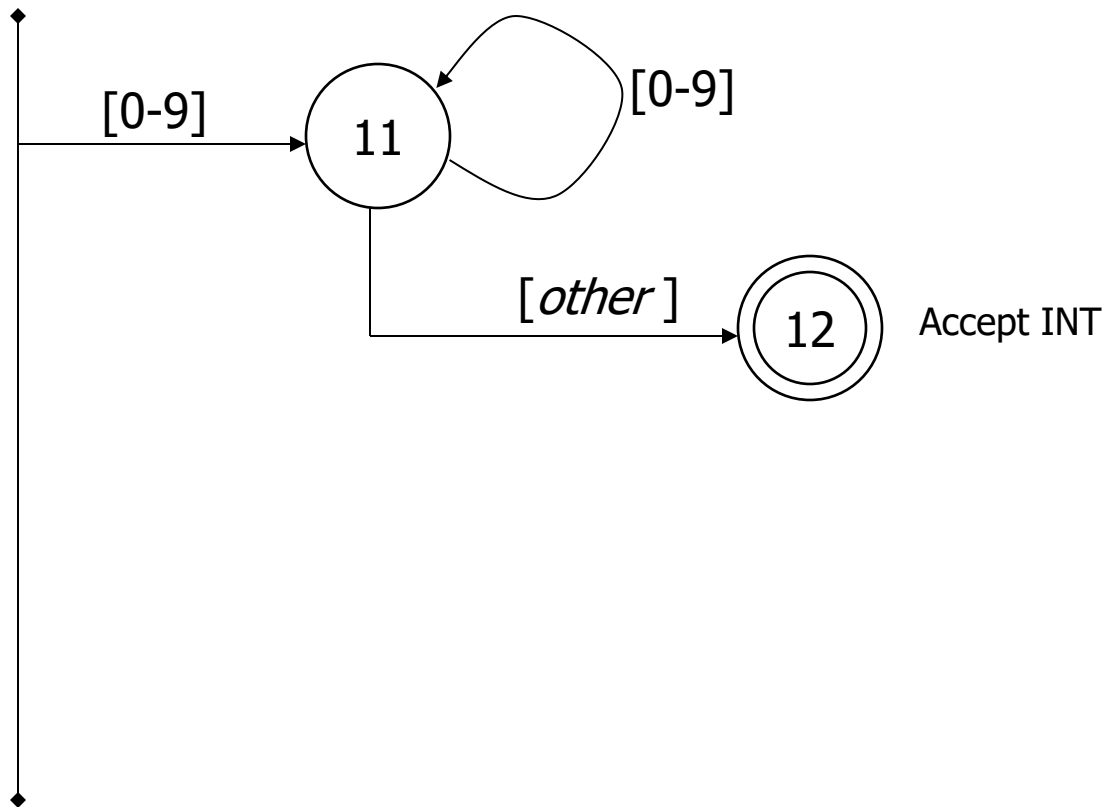

Scanner DFA Example (4)

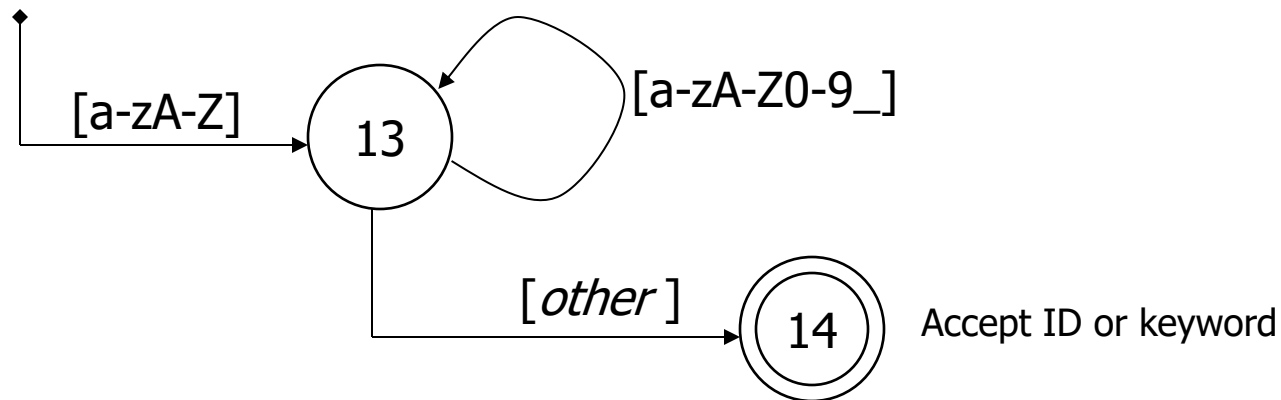

- Strategies for handling identifiers vs keywords
 - Hand-written scanner: look up identifier-like things in table of keywords to classify (good application of perfect hashing)
 - Machine-generated scanner: generate DFA with appropriate transitions to recognize keywords
 - Lots 'o states, but efficient (no extra lookup step)

Implementing a Scanner by Hand – Token Representation

- A token is a simple, tagged structure

```
public class Token {
    public Kind kind;        // token's lexical class
    public int intVal;      // integer value if class = INT
    public String id;       // actual identifier if class = ID
    // useful extra information for debugging / diagnostics:
    public int line;
    public int column;
    public enum Kind {      // lexical classes:
        EOF,                // "end of file" token
        ID,                 // identifier, not keyword
        INT,                // integer
        LPAREN,             // punctuation ...
        SCOLN,
        WHILE,              // keywords ...
        // etc. etc. etc. ...
    }
}
```

Simple Scanner Example

```
// global state and methods
```

```
static char nextch;    // next unprocessed input character
```

```
// advance to next input char
```

```
void getch() { ... }
```

```
// skip whitespace and comments
```

```
void skipWhitespace() { ... }
```

Scanner getToken() method

```
// return next input token
public Token getToken() {
    Token result;

    skipWhitespace();

    if (no more input) {
        result = new Token(Token.Kind.EOF); return result;
    }

    switch(nextch) {
        case '(': result = new Token(Token.Kind.LPAREN); getch(); return result;
        case ')': result = new Token(Token.Kind.RPAREN); getch(); return result;
        case ';': result = new Token(Token.Kind.SCOLON); getch(); return result;

        // etc. ...
    }
}
```

getToken() (2)

```
case '!': // ! or !=
    getch();
    if (nextch == '=') {
        result = new Token(Token.Kind.NEQ); getch(); return result;
    } else {
        result = new Token(Token.Kind.NOT); return result;
    }
```

```
case '<': // < or <=
    getch();
    if (nextch == '=') {
        result = new Token(Token.Kind.LEQ); getch(); return result;
    } else {
        result = new Token(Token.Kind.LESS); return result;
    }
// etc. ...
```

getToken() (3)

```
case '0': case '1': case '2': case '3': case '4':  
case '5': case '6': case '7': case '8': case '9':  
    // integer constant  
    String num = nextch;  
    getch();  
    while (nextch is a digit) {  
        num = num + nextch; getch();  
    }  
    result = new Token(Token.Kind.INT, Integer.parseInt(num));  
    return result;  
...
```

getToken() (4)

```
case 'a': ... case 'z':
case 'A': ... case 'Z': // id or keyword
  string s = nextch; getch();
  while (nextch is a letter, digit, or underscore) {
    s = s + nextch; getch();
  }
  if (s is a keyword) {
    result = new Token(keywordTable.getKind(s));
  } else {
    result = new Token(Token.Kind.ID, s);
  }
  return result;
```

MiniJava Scanner Generation

- We'll use the jflex tool to automatically create a scanner from a specification file
- We'll use the CUP tool to automatically create a parser from a specification file
- Token class defs. are shared by jflex and CUP. Lexical classes are listed in CUP's input file and it generates the token class definition.
- Details in ~~next~~ this week's sections

Coming Attractions

- First homework: paper exercises on regular expressions, automata, etc.
- Then: first part of the compiler assignment – the scanner
- Next topic: grammars and parsing
 - Will do LR parsing first – we need this for the project – then LL (recursive-descent) parsing, which you should also know.
 - Good time to start reading ahead.