



Lecture 14: BFS, DFS, Graph problems intro

CSE 373: Data Structures and
Algorithms

Administrivia

Due date reminders

- Project 3 due Wednesday May 6th
- Exercise 3 out tonight, due Friday May 8th

Project 2 hit a little hard

- Reminder – 7 late days
- Need a partner? Fill out the partner interest form on piazza
- Please don't struggle alone for too long, we're here to help
- Fill out the project feedback form on canvas

Midterm grades coming next week

Post-CSE 373 pathways session – fill out your time availability (google form on piazza) so we can try to choose a time that works for the most people

Roadmap for today

- review Wednesday intro to graphs key points
- s-t path problem
- BFS/DFS
 - visually
 - pseudocode
 - modifications to solve problems
- shortest path problem (for unweighted graphs)

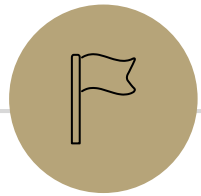

Introduction to Graphs

Inter-data Relationships

Arrays

Categorically associated

Sometimes ordered

Typically independent

Elements only store pure data, no connection info

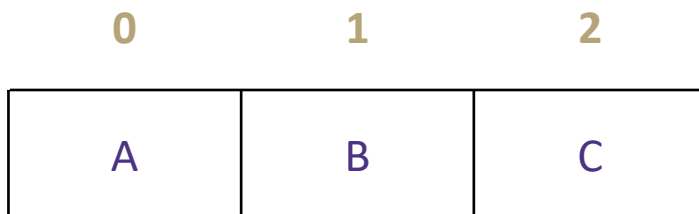

Trees

Directional Relationships

Ordered for easy access

Limited connections

Elements store data and connection info

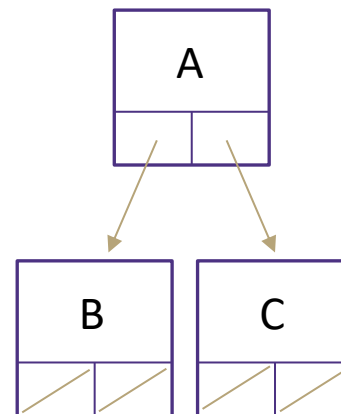

Graphs

Multiple relationship connections

Relationships dictate structure

Connection freedom!

Both elements and connections can store data

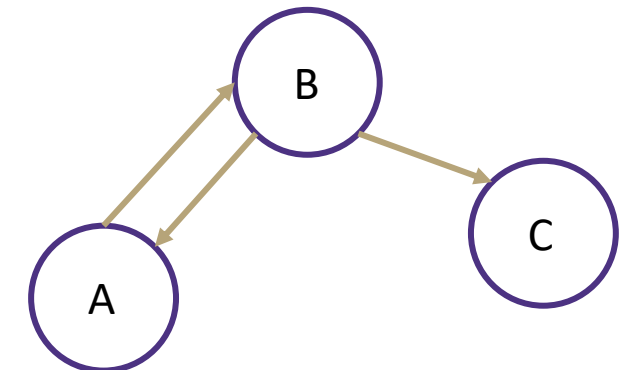

Graphs

Everything is graphs.

Most things we've studied this quarter can be represented by graphs.

- BSTs are graphs
- Linked lists? Graphs.
- Heaps? Also can be represented as graphs.
- Those trees we drew in the tree method? Graphs.

But it's not just data structures that we've discussed...

- Google Maps database? Graph.
- Facebook? They have a "graph search" team. Because it's a graph
- Gitlab's history of a repository? Graph.
- Those pictures of prerequisites in your program? Graphs.
- Family tree? That's a graph

Applications

Physical Maps

- Airline maps
 - Vertices are airports, edges are flight paths
- Traffic
 - Vertices are addresses, edges are streets

Relationships

- Social media graphs
 - Vertices are accounts, edges are follower relationships
- Code bases
 - Vertices are classes, edges are usage

Influence

- Biology
 - Vertices are cancer cell destinations, edges are migration paths

Related topics

- Web Page Ranking
 - Vertices are web pages, edges are hyperlinks
- Wikipedia
 - Vertices are articles, edges are links

SO MANY MORREEEE

www.allthingsgraphed.com

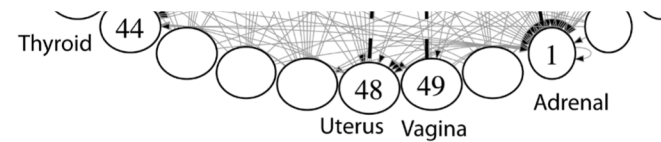
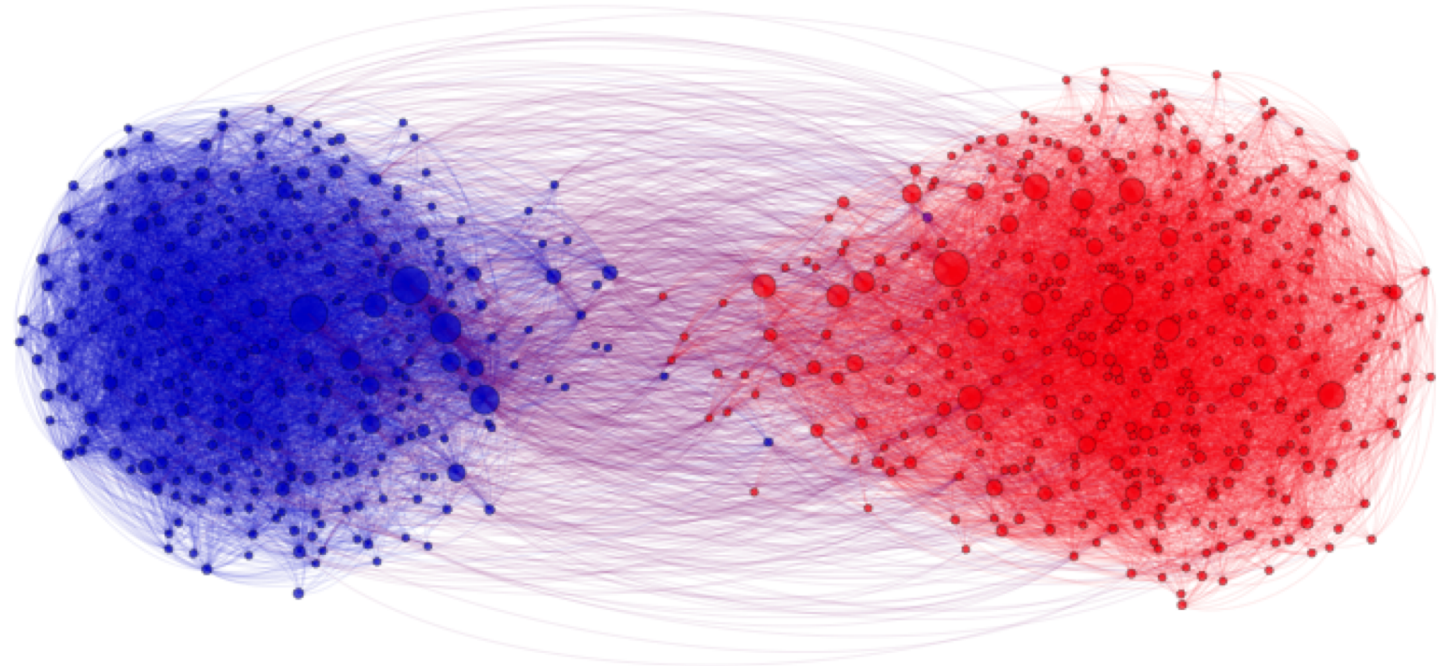
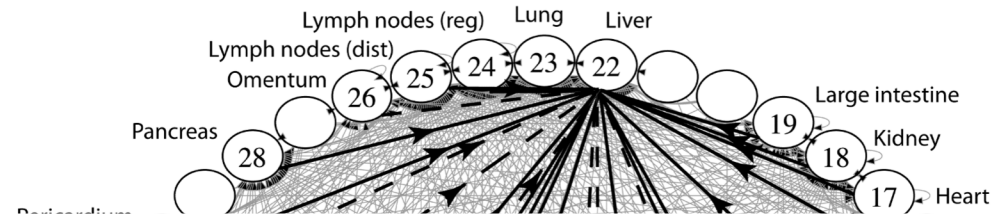

Graph: Formal Definition

A **graph** is defined by a pair of sets $G = (V, E)$ where...

- V is a set of **vertices**

- A vertex or “node” is a data entity

$V = \{ A, B, C, D, E, F, G, H \}$

- E is a set of **edges**

- An edge is a connection between two vertices

$E = \{ (A, B), (A, C), (A, D), (A, H),$
 $(C, B), (B, D), (D, E), (D, F),$
 $(F, G), (G, H) \}$

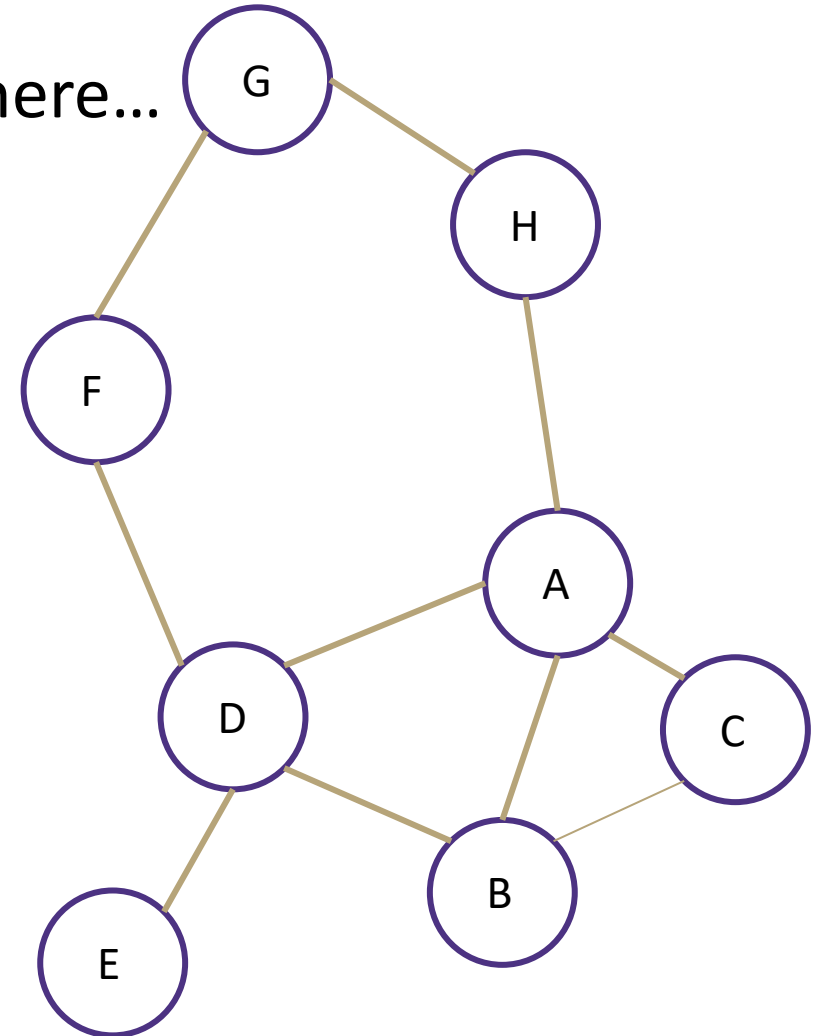

Graph Vocabulary

Graph Direction

- **Undirected graph** – edges have no direction and are two-way

$V = \{ \text{Karen, Jim, Pam} \}$

$E = \{ (\text{Jim, Pam}), (\text{Jim, Karen}) \}$ *inferred (Karen, Jim) and (Pam, Jim)*

- **Directed graphs** – edges have direction and are thus one-way

$V = \{ \text{Gunther, Rachel, Ross} \}$

$E = \{ (\text{Gunther, Rachel}), (\text{Rachel, Ross}), (\text{Ross, Rachel}) \}$

Degree of a Vertex

- **Degree** – the number of edges connected to that vertex

Karen : 1, Jim : 1, Pam : 1

- **In-degree** – the number of directed edges that point to a vertex

Gunther : 0, Rachel : 2, Ross : 1

- **Out-degree** – the number of directed edges that start at a vertex

Gunther : 1, Rachel : 1, Ross : 1

Undirected Graph:

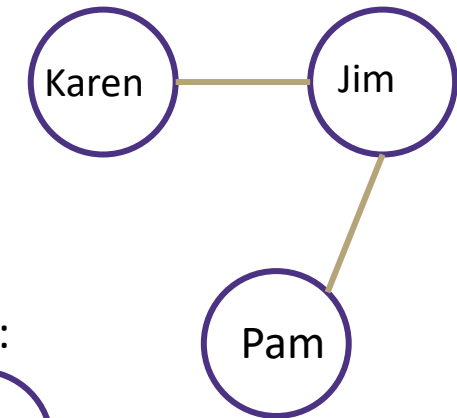

Directed Graph:

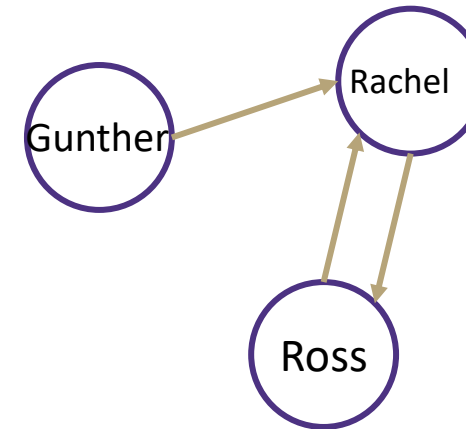

Some examples

For each of the following think about what you should choose for vertices and edges.

The internet

- **Vertices:** webpages. **Edges** from a to b if a has a hyperlink to b.

Family tree

- **Vertices:** people. **Edges:** from parent to child, maybe for marriages too?

Input data for the “6 Degrees of Kevin Bacon” game

- **Vertices:** actors. **Edges:** if two people appeared in the same movie
- Or: **Vertices** for actors and movies, **edge** from actors to movies they appeared in.

Course Prerequisites

- **Vertices:** courses. **Edge:** from a to b if a is a prereq for b.

Adjacency Matrix

In an adjacency matrix $a[u][v]$ is 1 if there is an edge (u,v) , and 0 otherwise.

Worst-case Time Complexity

($|V| = n$, $|E| = m$):

Add Edge: $\Theta(1)$

Remove Edge: $\Theta(1)$

Check edge exists from (u,v) : $\Theta(1)$

Get outneighbors of u : $\Theta(n)$

Get inneighbors of u : $\Theta(n)$

Space Complexity: $\Theta(n^2)$

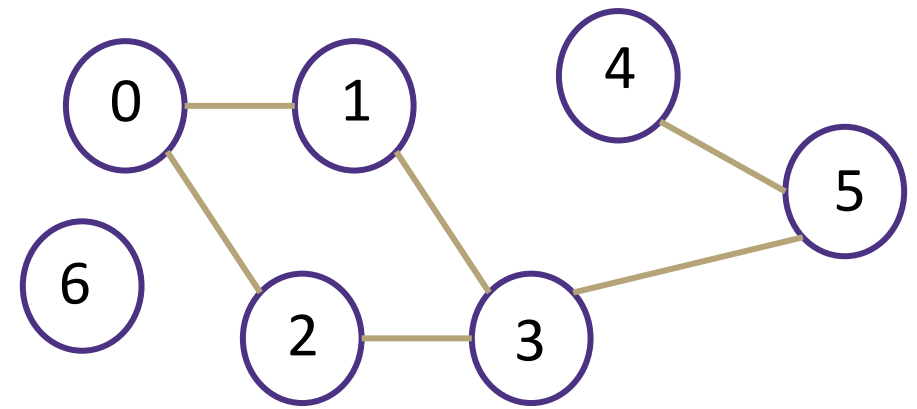

	0	1	2	3	4	5	6
0	0	1	1	0	0	0	0
1	1	0	0	1	0	0	0
2	1	0	0	1	0	0	0
3	0	1	1	0	0	1	0
4	0	0	0	0	0	1	0
5	0	0	0	1	1	0	0
6	0	0	0	0	0	0	0

Adjacency List

Create a Dictionary of size V from type V to Collection of E

If $(x,y) \in E$ then add y to the set associated with the key x

An array where the u^{th} element contains a list of neighbors of u .

Directed graphs: list of out-neighbors (a[u] has v for all $(u,v) \in E$)

Time Complexity ($|V| = n, |E| = m$):

Add Edge: $\Theta(1)$

Remove Edge (u,v) : $\Theta(\text{deg}(u))$

Check edge exists from (u,v) : $\Theta(\text{deg}(u))$

Get neighbors of u (out): $\Theta(\text{deg}(u))$

Get neighbors of u (in): $\Theta(n + m)$

Space Complexity: $\Theta(n + m)$

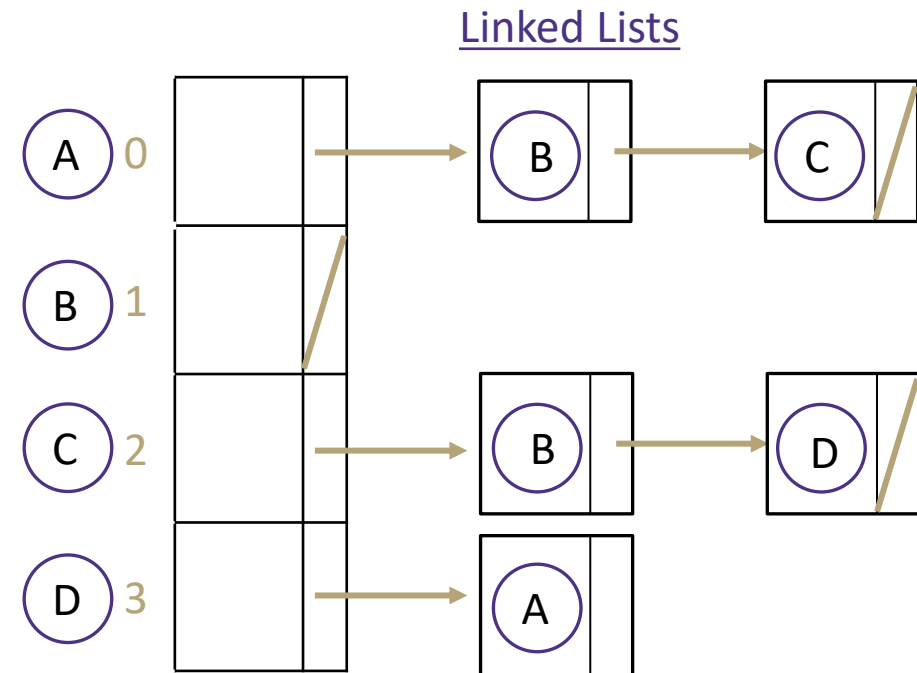
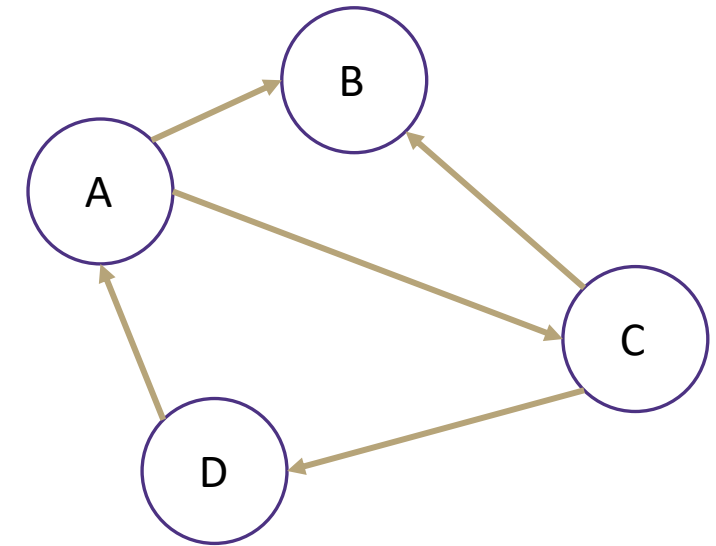

Adjacency List

Create a Dictionary of size V from type V to Collection of E

If $(x,y) \in E$ then add y to the set associated with the key x

An array where the u^{th} element contains a list of neighbors of u .

Directed graphs: list of out-neighbors (a[u] has v for all $(u,v) \in E$)

Time Complexity ($|V| = n, |E| = m$):

Add Edge: $\Theta(1)$

Remove Edge (u,v) : $\Theta(1)$

Check edge exists from (u,v) : $\Theta(1)$

Get neighbors of u (out): $\Theta(\text{deg}(u))$

Get neighbors of u (in): $\Theta(n)$

Space Complexity: $\Theta(n + m)$

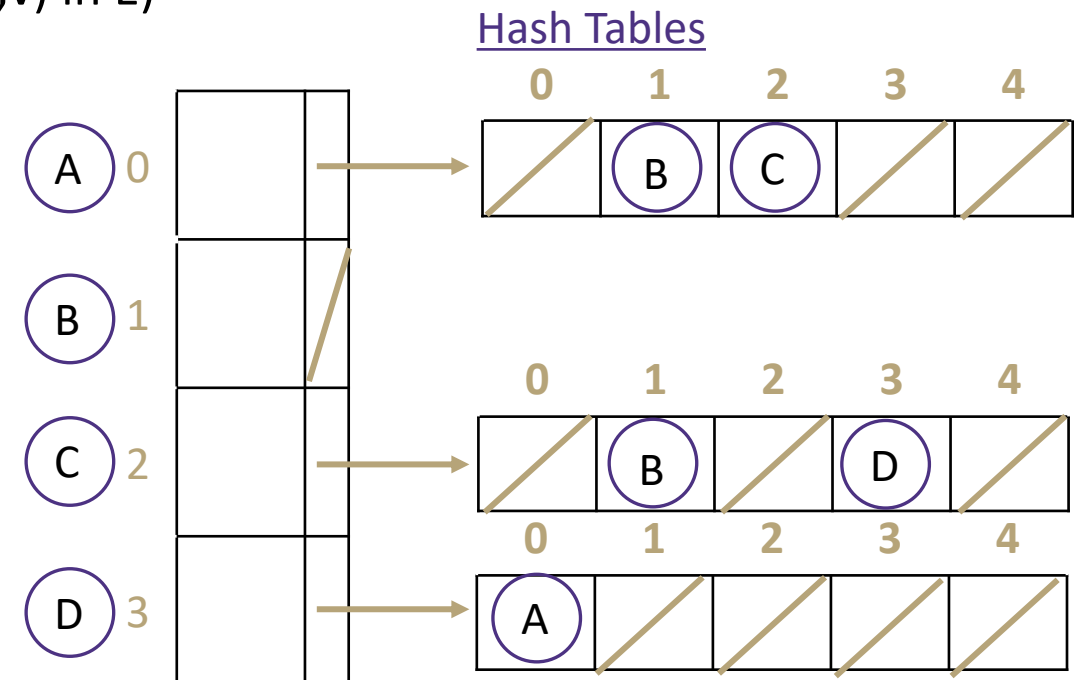
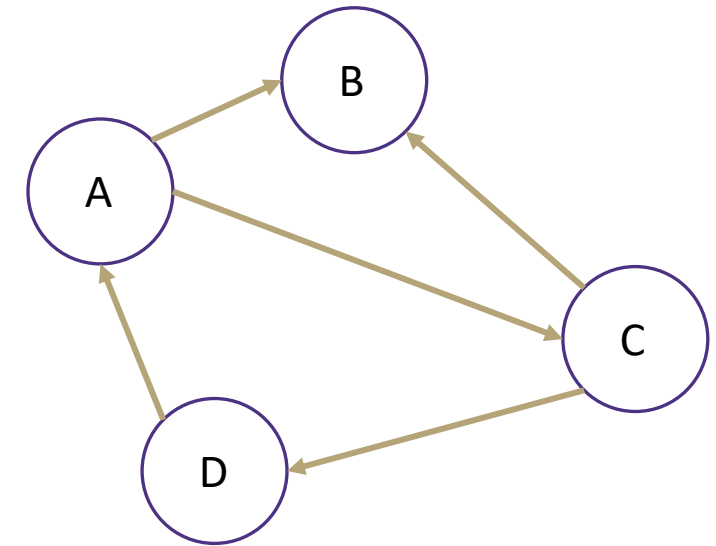

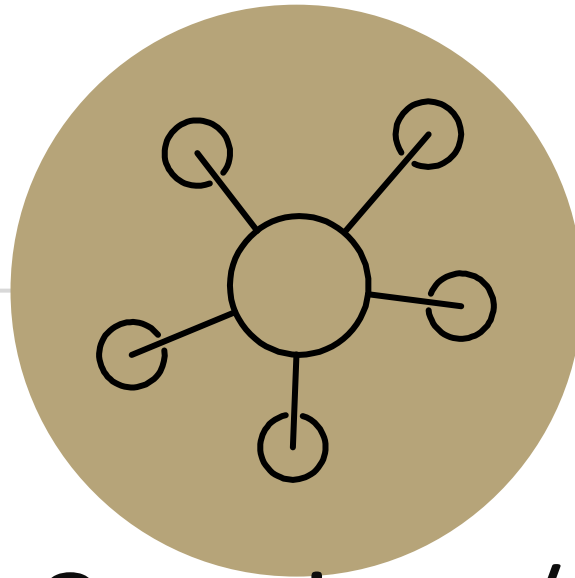

Questions / clarifications on anything?

relevant ideas for today

- vertices, edges, definitions
- graphs model relationships between real data (you can choose your vertices and edges to)
- different graph implementations exist

Roadmap for today

- review Wednesday intro to graphs key points
- graph problems
- s-t path problem
- detour: BFS/DFS
 - visually
 - pseudocode
 - modifications to solve problems (circling back to s-t path)
- shortest path problem (for unweighted graphs)

Graph problems

There are lots of interesting questions we can ask about a graph:

- What is the shortest route from S to T?
- What is the longest without cycles?
- Are there cycles?
- Is there a tour (cycle) you can take that only uses each node (station) exactly once?
- Is there a tour (cycle) that uses each edge exactly once?

Graph problems

Some well known graph problems and their common names:

- s-t Path. Is there a path between vertices s and t ?
- Connectivity. Is the graph connected?
- Biconnectivity. Is there a vertex whose removal disconnects the graph?
- Shortest s-t Path. What is the shortest path between vertices s and t ?
- Cycle Detection. Does the graph contain any cycles?
- Euler Tour. Is there a cycle that uses every edge exactly once?
- Hamilton Tour. Is there a cycle that uses every vertex exactly once?
- Planarity. Can you draw the graph on paper with no crossing edges?
- Isomorphism. Are two graphs the same graph (in disguise)?

Graph problems are among the most mathematically rich areas of CS theory!

s-t path Problem

s-t path problem

- Given source vertex **s** and a target vertex **t**, does there exist a path between **s** and **t**?

Why does this problem matter? Some possible context:

- real life maps and trip planning – can we get from one location (vertex) to another location (vertex) given the current available roads (edges)
- family trees and checking ancestry – are two people (vertices) related by some common ancestor (edges for direct parent/child relationships)
- game states (Artificial Intelligence) can you win the game from the current vertex (think: current board position)? Are there moves (edges) you can take to get to the vertex that represents an already won game?

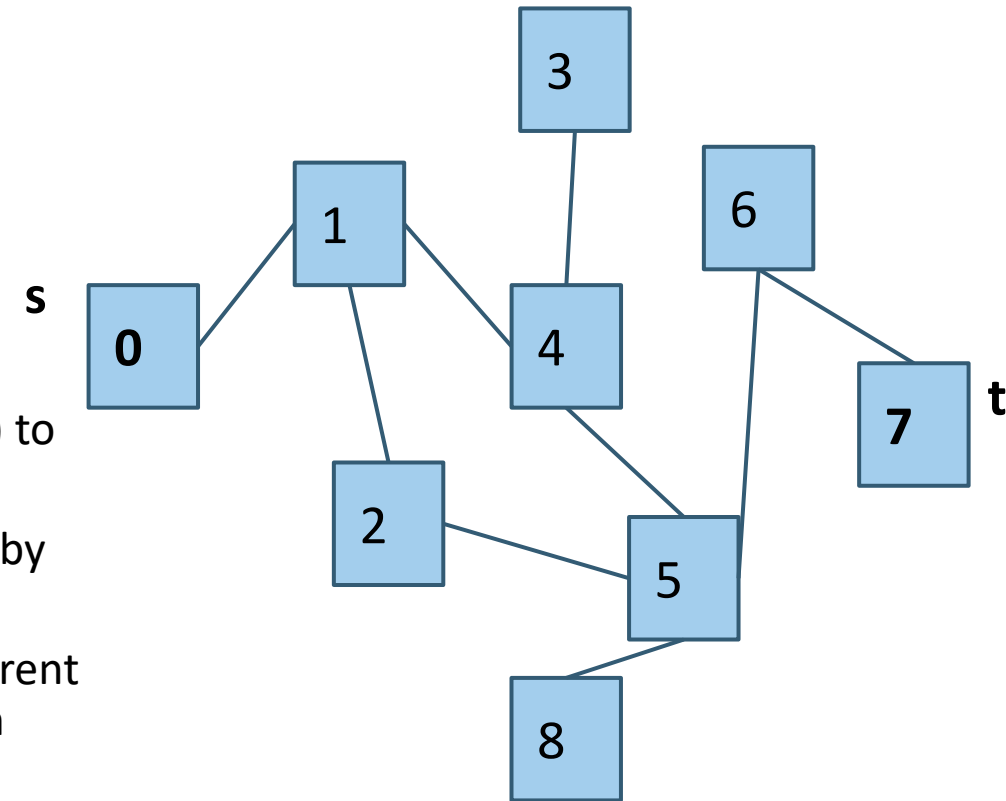

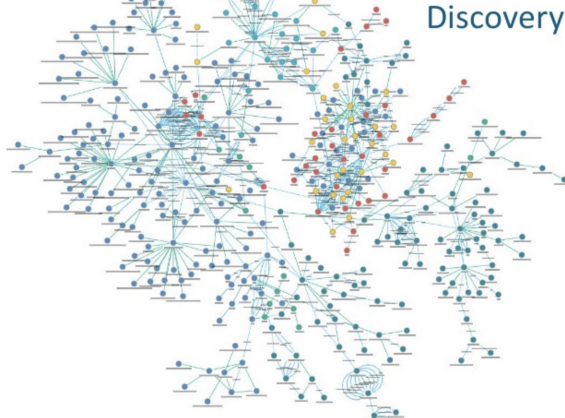

s-t path Problem

s-t path problem

- Given source vertex **s** and a target vertex **t**, does there exist a path between **s** and **t**?

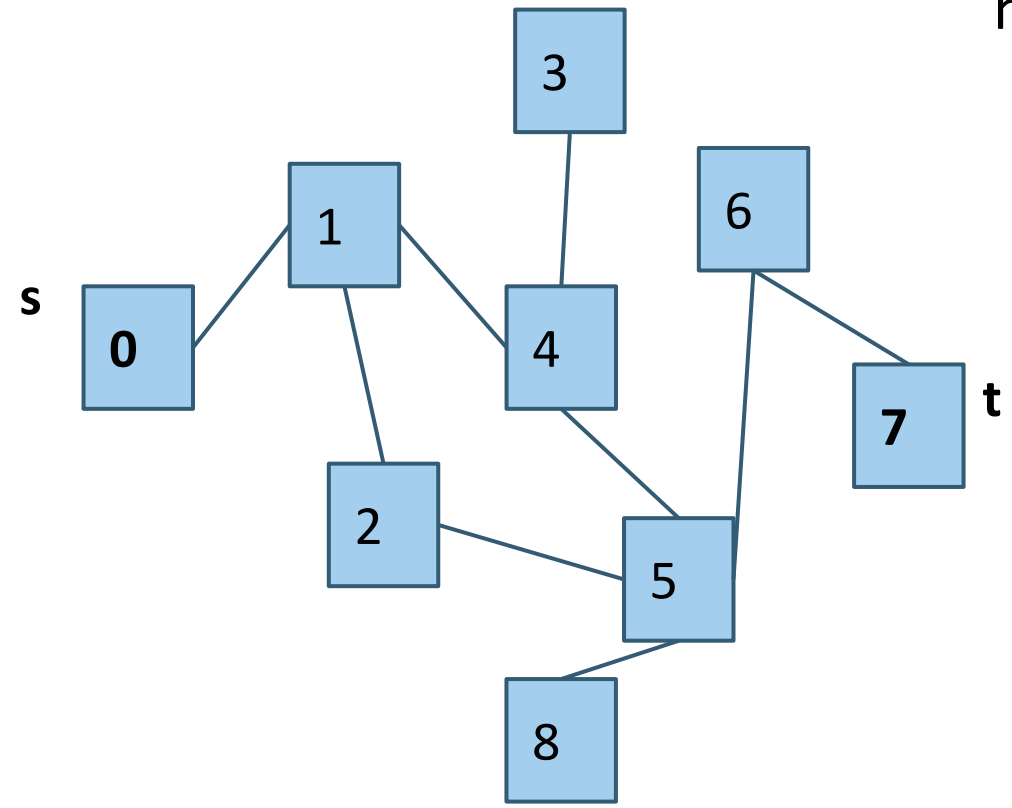

❖ What's the answer for this graph on the left, and how did we get that answer as humans?

- ❖ We can see there's edges that are visually in between **s** and **t**, and we can try out an example path and make sure that by traversing that path you can get from **s** to **t**.
- ❖ We know that doesn't scale that well though, so now let's try to define a more algorithmic (comprehensive) way to find these paths. The main idea is: starting from the specified **s**, try traversing through every single possible path possible that's not redundant to see if it could lead to **t**.

traversals are really important to solving this problem / problems in general, so slight detour to talk about them, we'll come back to this though

Graph traversals: DFS (should feel similar to 143 in the tree context)

Depth First Search - a traversal on graphs (or on trees since those are also graphs) where you traverse “deep nodes” before all the shallow ones

High-level DFS: you go as far as you can down one path till you hit a dead end (no neighbors are still undiscovered or you have no neighbors). Once you hit a dead end, you backtrack / undo until you find some options/edges that you haven't actually tried yet.

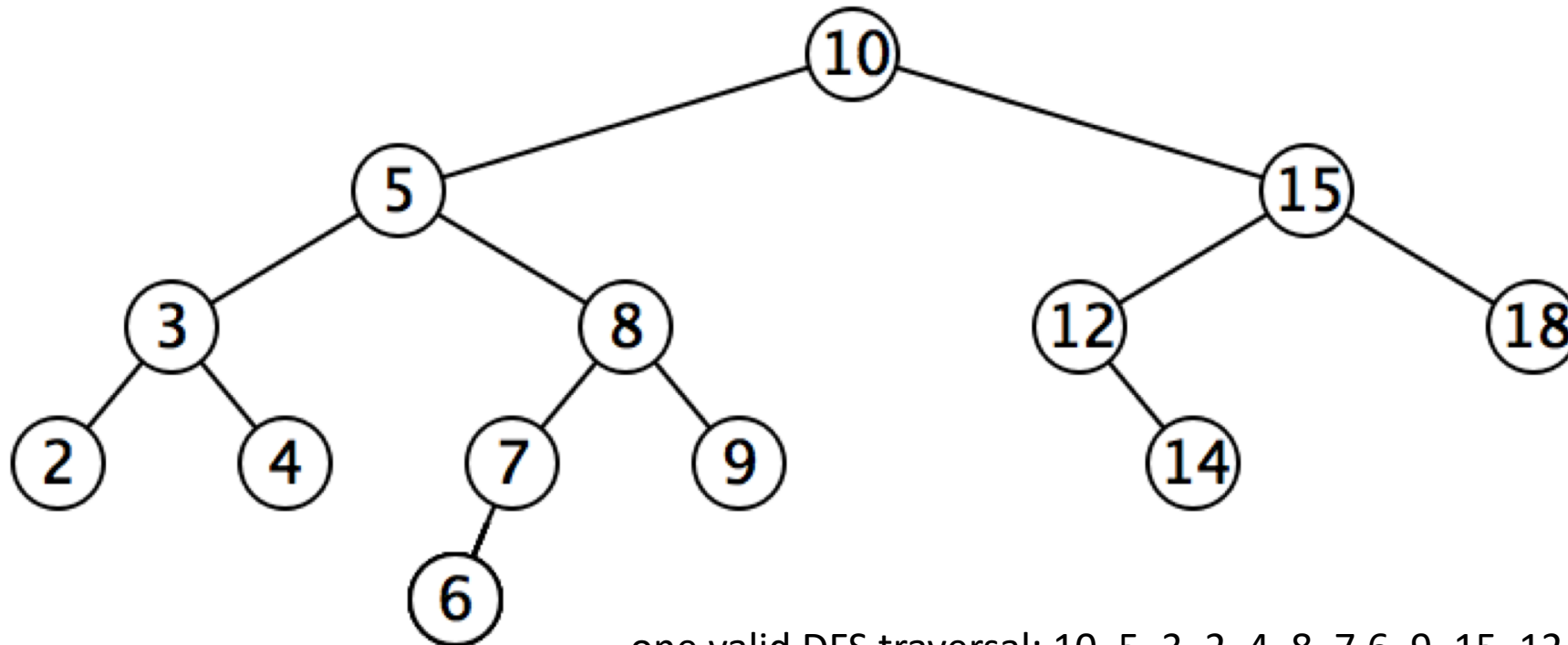

Kind of like wandering a maze – if you get stuck at a dead end (since you physically have to go and try it out to know it's a dead end), trace your steps backwards towards your last decision and when you get back there, choose a different option than you did before.

one valid DFS traversal: 10, 5, 3, 2, 4, 8, 7, 6, 9, 15, 12, 14, 18

Graph traversals: BFS

Breadth First Search - a traversal on graphs (or on trees since those are also graphs) where you traverse level by level. So in this one we'll get to all the shallow nodes before any "deep nodes".

Intuitive ways to think about BFS:

- opposite way of traversing compared to DFS
- a sound wave spreading from a starting point, going outwards in all directions possible.
- mold on a piece of food spreading outwards so that it eventually covers the whole surface

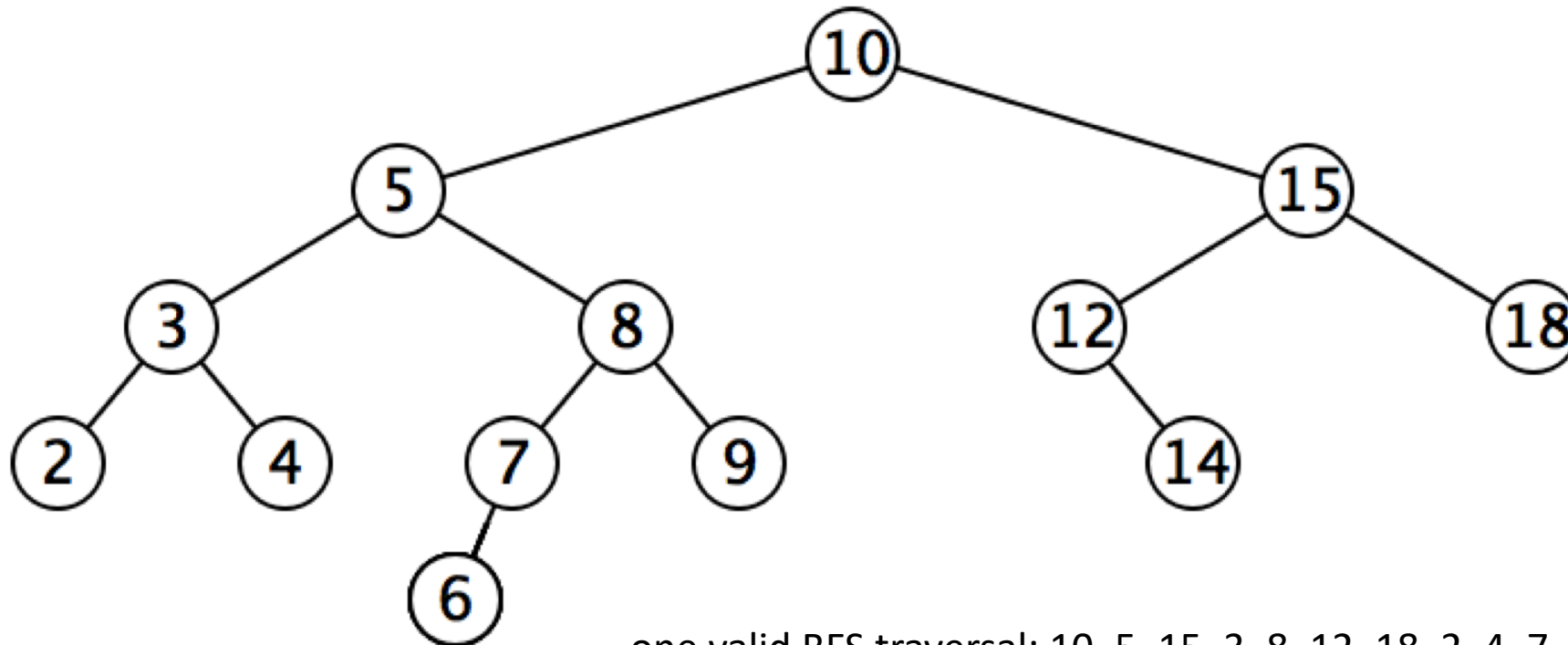

one valid BFS traversal: 10, 5, 15, 3, 8, 12, 18, 2, 4, 7, 9, 14, 6

Graph traversals: BFS and DFS on more graphs

In DFS, you go as far as you can down one path till you hit a dead end (no neighbors are still undiscovered or you have no neighbors).

Once you hit a dead end, you backtrack / undo until you find some options/edges that you haven't actually tried yet.

In BFS, you traverse level by level

Take 2 minutes and try to come up with two possible traversal orderings **starting with the 0 node:**

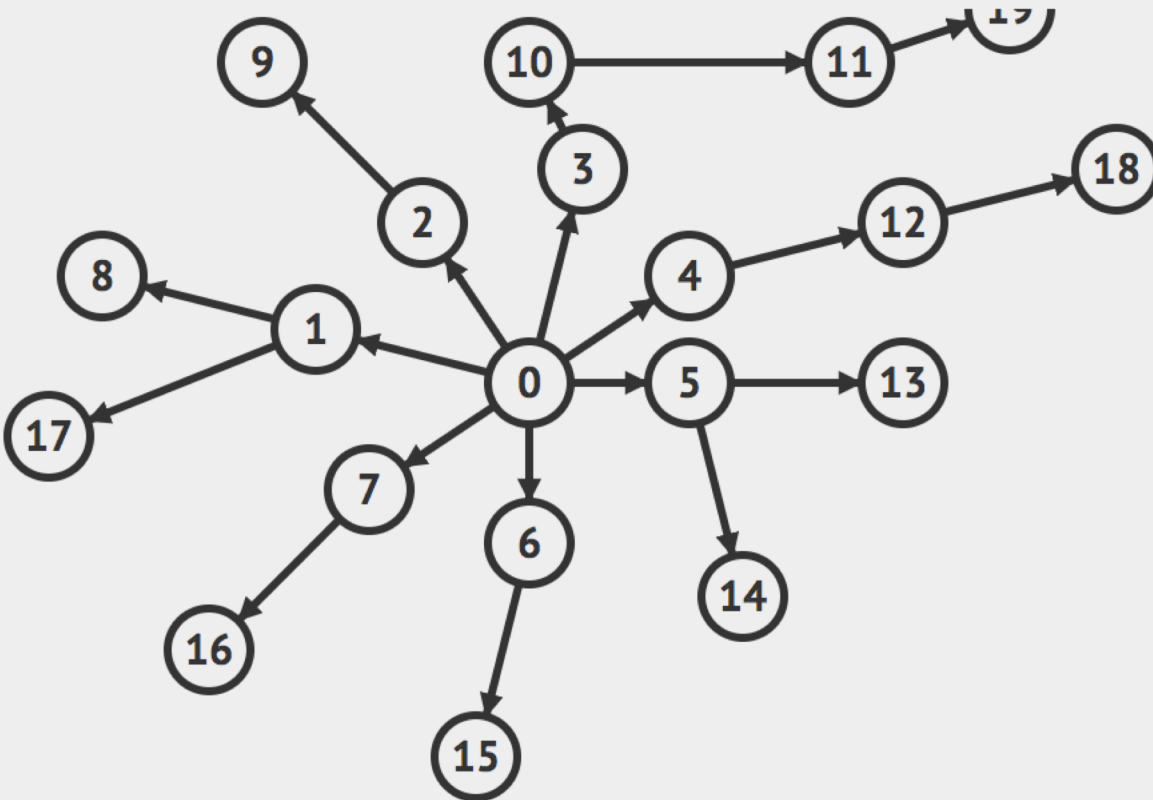

-a BFS ordering (ordering within each layer doesn't matter / any ordering is valid)

-a DFS ordering (ordering which path you choose next at any point doesn't matter / any is valid as long as you haven't explored it before)

@ordering choices will be more stable when we have code in front of us, but not the focus / point of the traversals so don't worry about it

Graph traversals: BFS and DFS on more graphs

In DFS, you go as far as you can down one path till you hit a dead end (no neighbors are still undiscovered or you have no neighbors).

Once you hit a dead end, you backtrack / undo until you find some options/edges that you haven't actually tried yet.

In BFS, you traverse level by level

Take a minute and try to come up with two possible traversal orderings **starting with the 0 node**:

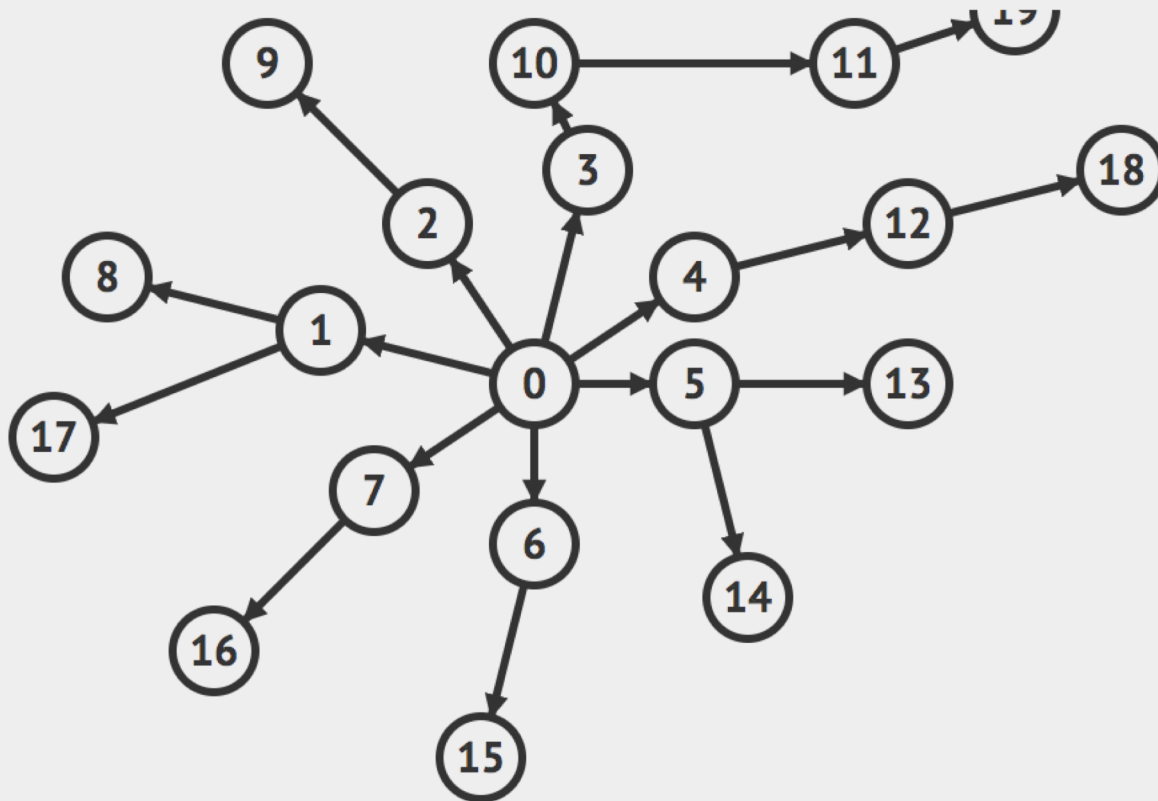

- a BFS ordering (ordering within each layer doesn't really matter / any ordering is valid)
 - 0, [1, 2, 3, 4, 5, 6, 7], [8, 9, 10, 12, 13, 14, 15, 16, 17], [11, 18], [19]
- a DFS ordering (ordering which path you choose next at any point doesn't matter / any is valid as long as you haven't explored it before)
 - 0, 2, 9, 3, 10, 11, 19, 4, 12, 18, 5, 13, 14, 6, 15, 7, 16, 1, 17, 8

Graph traversals: BFS and DFS on more graphs

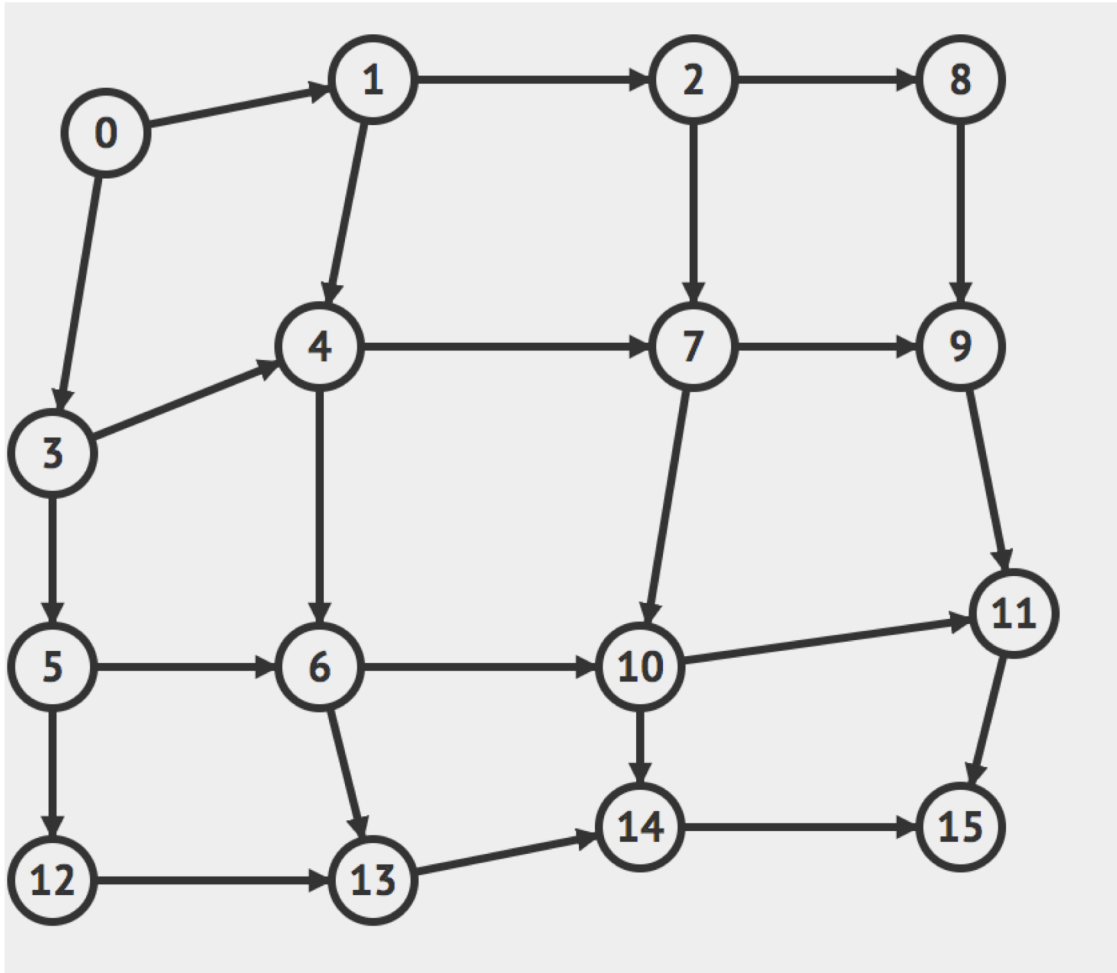

<https://visualgo.net/en/dfsdfs>

- click on draw graph to create your own graphs and run BFS/DFS on them!
- check out visualgo.net for more really cool interactive visualizations
- or do your own googling – there are a lot of cool visualizations out there 😊!

BFS pseudocode (some details not Java specific)

```
bfs(Graph graph, Vertex start) {  
    // stores the remaining vertices to visit in the BFS  
    Queue<Vertex> perimeter = new Queue<>();  
  
    // stores the set of discovered vertices so we don't revisit them multiple times  
    Set<Vertex> discovered = new Set<>();  
  
    // kicking off our starting point by adding it to the perimeter  
    perimeter.add(start);  
    discovered.add(start);  
  
    while (!perimeter.isEmpty()) {  
        Vertex from = perimeter.remove();  
        for (E edge : graph.outgoingEdgesFrom(from)) {  
            Vertex to = edge.to();  
            if (!discovered.contains(to)) {  
                perimeter.add(to);  
                discovered.add(to);  
            }  
        }  
    }  
}
```

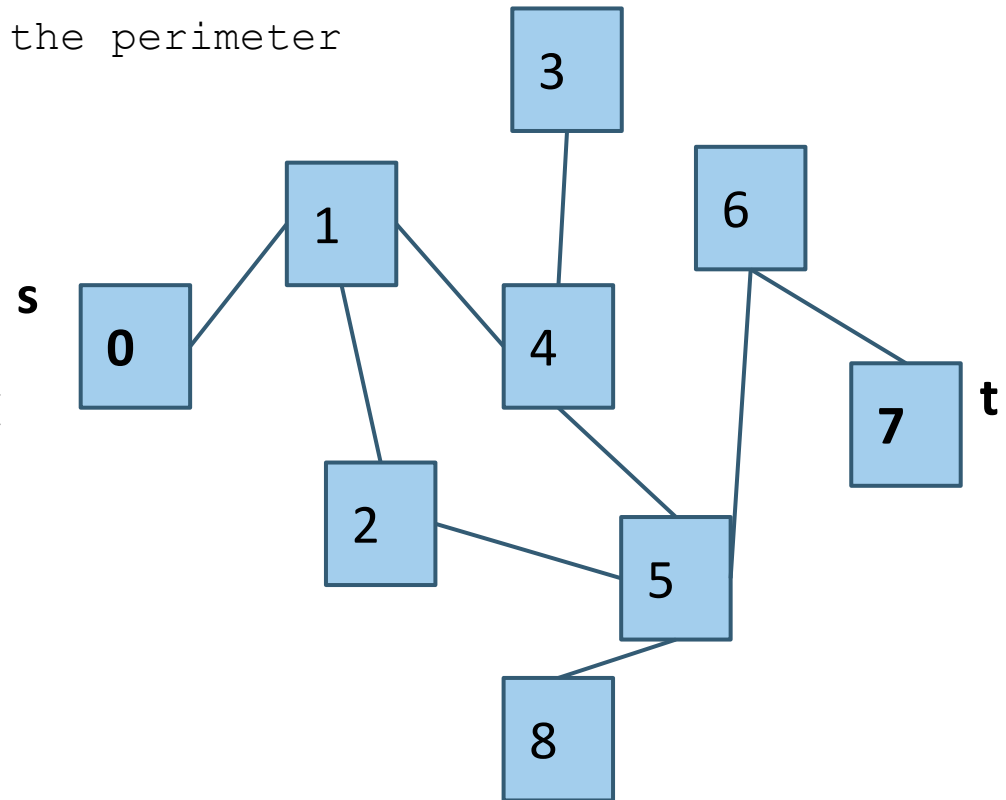

BFS pseudocode (some details not Java specific)

```
//. . . this is the main loop/code for BFS
while (!perimeter.isEmpty()) {
    Vertex from = perimeter.remove();
    for (E edge : graph.outgoingEdgesFrom(from)) {
        Vertex to = edge.to();
        if (!discovered.contains(to)) {
            perimeter.add(to);
            discovered.add(to)
        }
    }
}
```

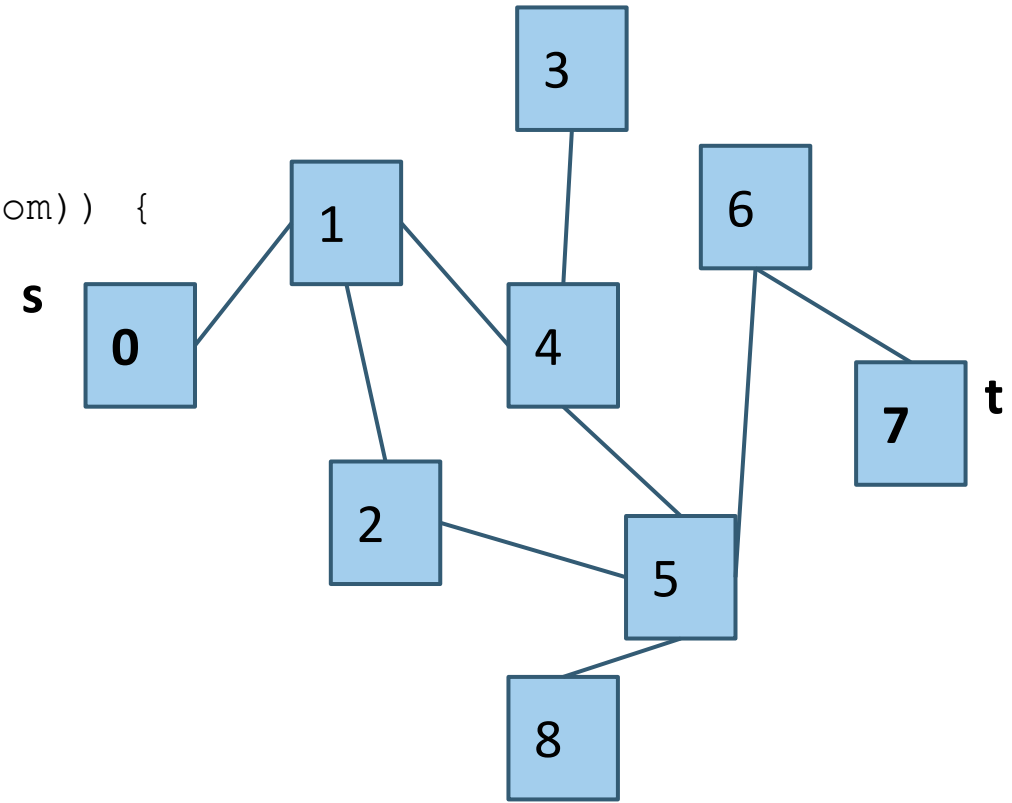

Perimeter queue:

Discovered set:

Expected levels starting the BFS from 0:

- 0
- 1
- 2 4
- 3 5
- 6 8
- 7

DFS pseudocode (some details not Java specific)

```
dfs(Graph graph, Vertex start) {  
    // stores the remaining vertices to visit in the DFS  
    Stack<Vertex> perimeter = new Stack<>(); //the only change you need to make to do DFS!  
  
    // stores the set of discovered vertices so we don't revisit them multiple times  
    Set<Vertex> discovered = new Set<>();  
  
    // kicking off our starting point by adding it to the perimeter  
    perimeter.add(start);  
    discovered.add(start);  
  
    while (!perimeter.isEmpty()) {  
        Vertex from = perimeter.remove();  
        for (E edge : graph.outgoingEdgesFrom(from)) {  
            Vertex to = edge.to();  
            if (!discovered.contains(to)) {  
                perimeter.add(to);  
                discovered.add(to)  
            }  
        }  
    }  
}
```

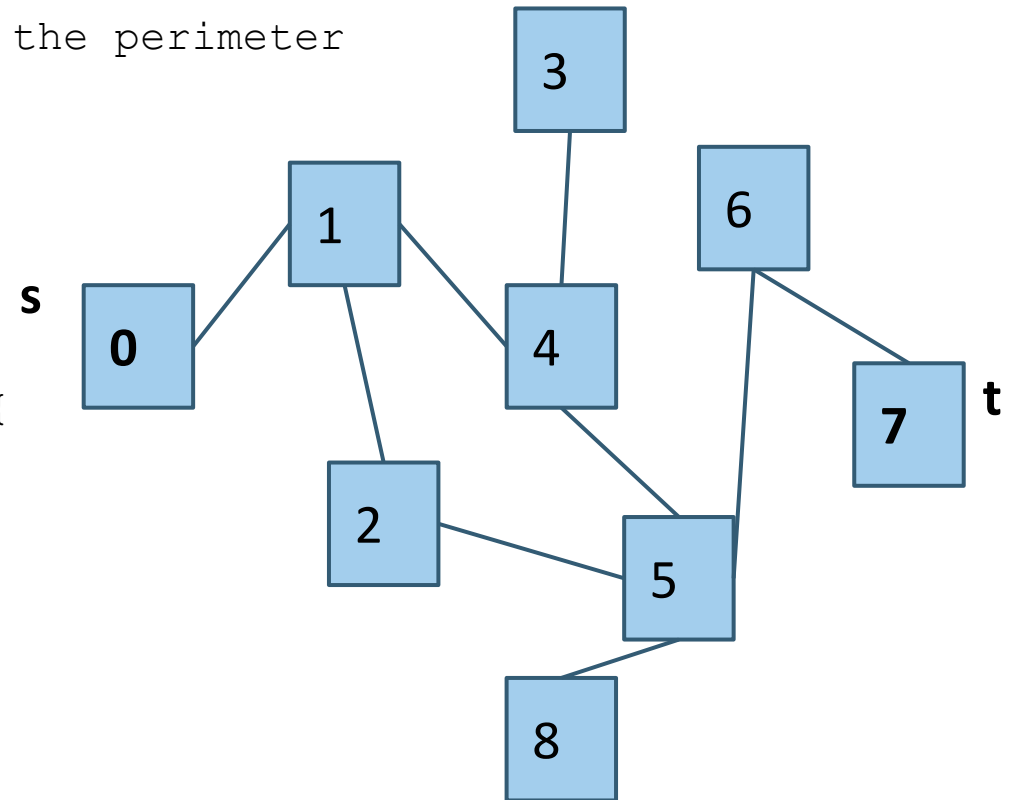

Modifying BFS and DFS

BFS and DFS are like the for loops over arrays for graphs. They're super fundamental to so many ideas, but when they're by themselves they don't do anything. Consider the following code:

```
for (int i = 0; i < n; i++) {  
    int x = arr[i];  
}  
  
while (!perimeter.isEmpty()) {  
    Vertex from = perimeter.remove();  
    for (E edge : graph.outgoingEdgesFrom(from)) {  
        Vertex to = edge.to();  
        if (!discovered.contains(to)) {  
            perimeter.add(to, newDist);  
            discovered.add(to)  
        }  
    }  
}
```

We actually need to do something with the data for it to be useful!

A lot of times to solve basic graph problems (which show up in technical interviews at this level), and often the answer is that you just need to describe / implement BFS/DFS with a small modification for your specific problem.

Now back to the s-t path problem...

Modifying BFS for the s-t path problem

```
//. . . this is the main loop/code for BFS
while (!perimeter.isEmpty()) {
    Vertex from = perimeter.remove();
    for (E edge : graph.outgoingEdgesFrom(from)) {
        Vertex to = edge.to();
        if (!discovered.contains(to)) {
            perimeter.add(to);
            discovered.add(to)
        }
    }
}
```

```
// with modifications to return true if
// there is a path where s can reach t
while (!perimeter.isEmpty()) {
    Vertex from = perimeter.remove();
    if (from == t) {
        return true;
    }
    for (E edge : graph.outgoingEdgesFrom(from))
        Vertex to = edge.to();
        if (!discovered.contains(to)) {
            perimeter.add(to);
            discovered.add(to)
        }
    }
}
return false;
```

Small note: for this s-t problem, we didn't really need the power of BFS in particular, just some way of looping through the graph starting at a particular point and seeing everything it was connected to. So we could have just as easily used DFS.

There are plenty of unique applications of both, however, and we'll cover some of them in this course – for a more comprehensive list, feel free to google or check out resources like:

- <https://www.geeksforgeeks.org/applications-of-breadth-first-traversal/>
- <https://www.geeksforgeeks.org/applications-of-depth-first-search/>

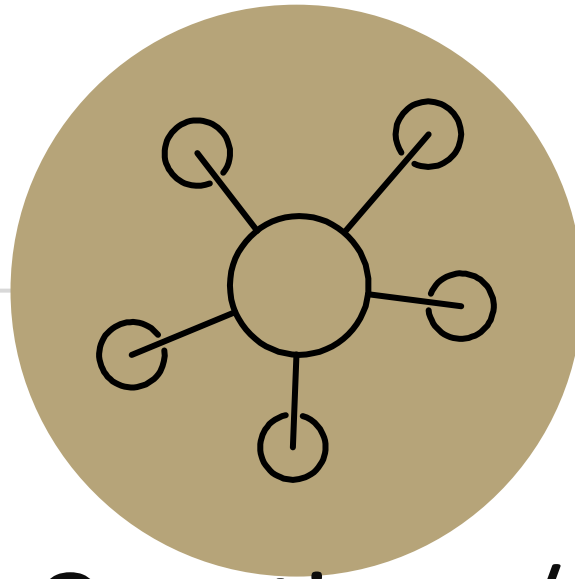

Questions / clarifications on anything?

we covered:

- s-t path problem
- BFS/DFS visually + high-level
- BFS/DFS pseudocode
- modifying BFS/DFS to solve s-t path problem

Roadmap for today

- review Wednesday intro to graphs key points
- graph problems
- s-t path problem
- detour: BFS/DFS
 - visually
 - pseudocode
 - modifications to solve problems (circling back to s-t path)
- shortest path problem (for unweighted graphs)

Shortest Path problem (unweighted graph)

- For the graph on the right, find **the shortest path (the path that has the fewest number of edges)** between the 0 node and the 5 node. Describe the path by describing each edge (i.e. (0, 1) edge).
- What's the answer? How did we get that as humans? How do we want to do it comprehensively defined in an algorithm?

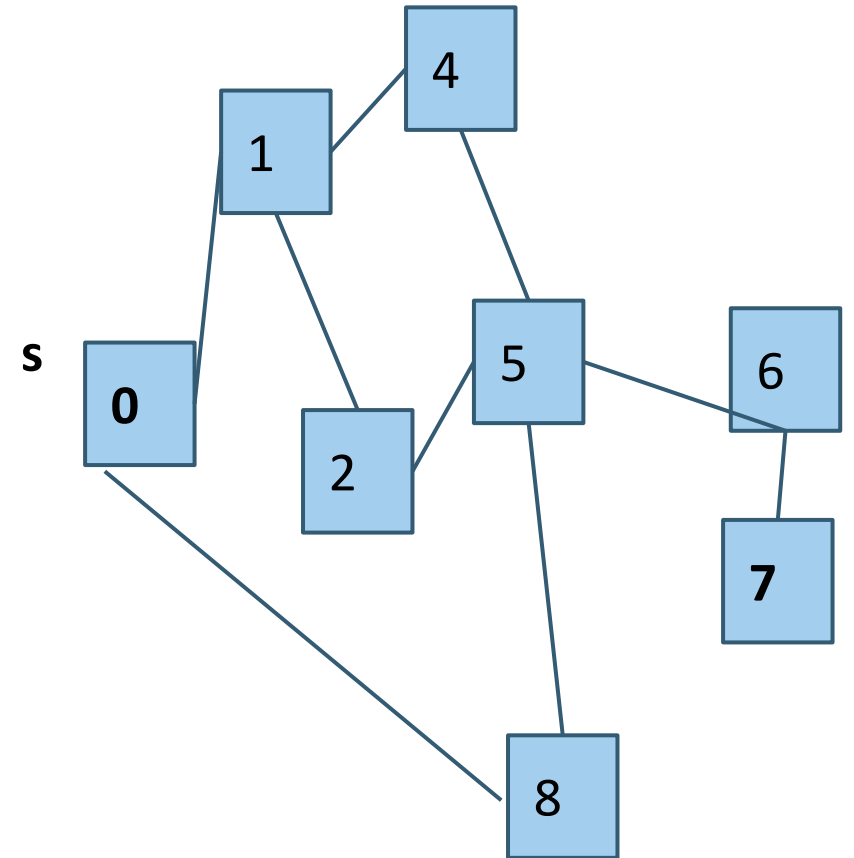

Shortest Path problem (unweighted graph)

how do we find a shortest paths?

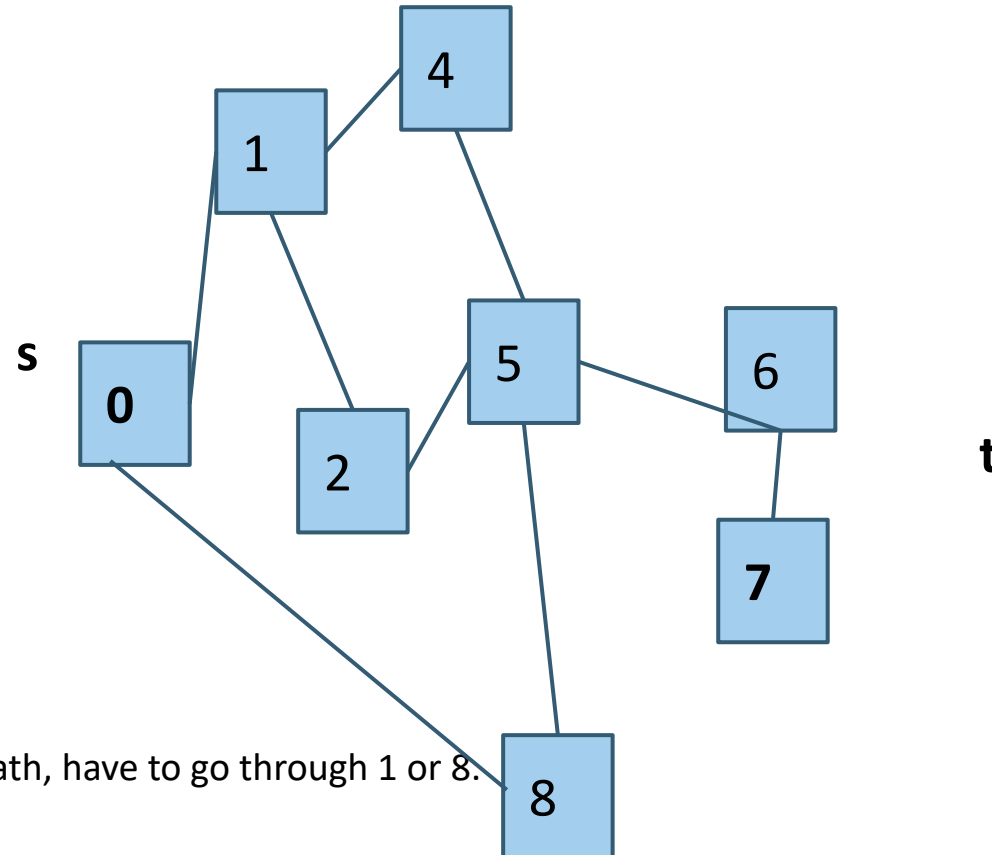

What's the shortest path from 0 to 0?

- Well....we're already there.

What's the shortest path from 0 to 1 or 8?

- Just go on the edge from 0

From 0 to 4 or 2 or 5?

- Can't get there directly from 0, if we want a length 2 path, have to go through 1 or 8.

From 0 to 6?

- Can't get there directly from 0, if we want a length 3 path, have to go through 5.

Shortest Path problem (unweighted graph) key idea

To find the set of vertices at distance k , just find the set of vertices at distance $k-1$, and see if any of them have an outgoing edge to an undiscovered vertex. Basically, if we traverse level by level and we're checking all the nodes that show up at each level comprehensively (and only recording the earliest time they show up), when we find our target at level k , we can keep using the edge that led to it from the previous level to justify the shortest path.

Do we already know an algorithm that can help us traverse the graph level by level?

Yes! BFS! Let's modify it to fit our needs.

Changes from traversal BFS:

- Every node now will have an associated distance (for convenience)
- Every node V now will have an associated predecessor edge that is the edge that connects V on the shortest path from S to V . The edges that each of the nodes store are the final result.

```
perimeter.add(start);
discovered.add(start);
start.distance = 0;
while (!perimeter.isEmpty()) {
    Vertex from = perimeter.remove();
    for (E edge : graph.outgoingEdgesFrom(from)) {
        Vertex to = edge.to();
        if (!discovered.contains(to)) {
            to.distance = from.distance + 1;
            to.predecessorEdge = edge;
            perimeter.add(to);
            discovered.add(to)
        }
    }
}
```

Unweighted Graphs

Use BFS to find shortest paths in this graph.

```
perimeter.add(start);
discovered.add(start);
start.distance = 0;
while (!perimeter.isEmpty()) {
    Vertex from = perimeter.remove();
    for (E edge : graph.outgoingEdgesFrom(from)) {
        Vertex to = edge.to();
        if (!discovered.contains(to)) {
            to.distance = from.distance + 1;
            to.predecessorEdge = edge;
            perimeter.add(to);
            discovered.add(to)
        }
    }
}
```

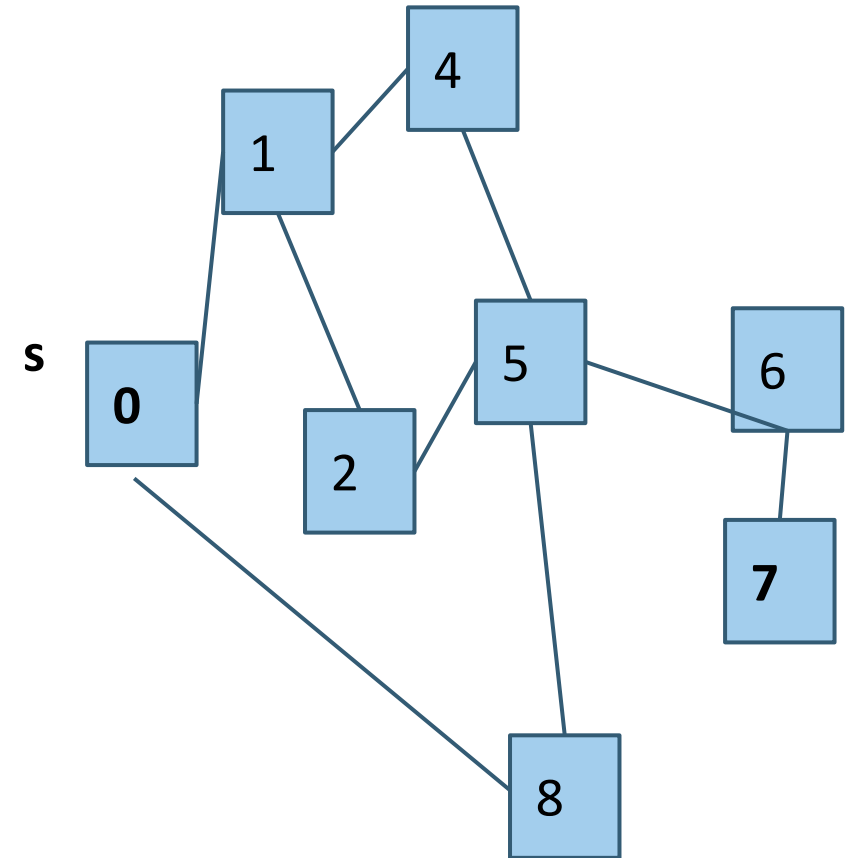

Unweighted Graphs

Use BFS to find shortest paths in this graph.

```
perimeter.add(start);
discovered.add(start);
start.distance = 0;
while (!perimeter.isEmpty()) {
    Vertex from = perimeter.remove();
    for (E edge : graph.outgoingEdgesFrom(from)) {
        Vertex to = edge.to();
        if (!discovered.contains(to)) {
            to.distance = from.distance + 1;
            to.predecessorEdge = edge;
            perimeter.add(to);
            discovered.add(to)
        }
    }
}
```

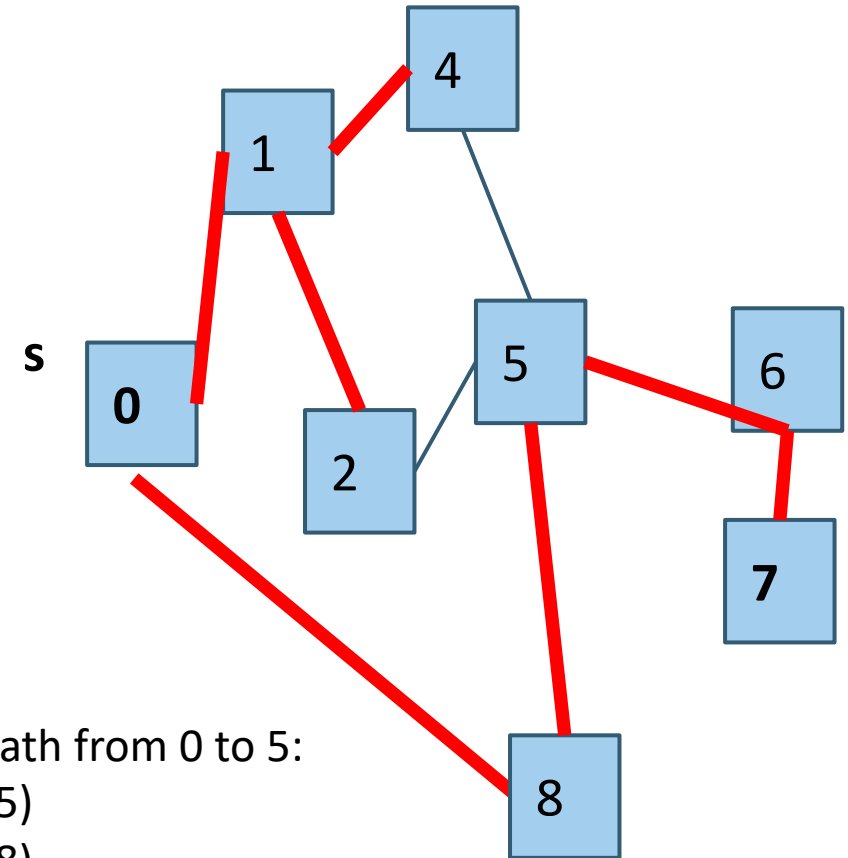

If trying to recall the best path from 0 to 5:
5's predecessor edge is (8, 5)
8's predecessor edge is (0, 8)
0 was the start vertex

Note: this BFS modification produces these edges, but there's extra work to figure out a specific path from a start / target

What about the target vertex?

Shortest Path Problem

Given: a directed graph G and vertices s, t

Find: the shortest path from s to t .

BFS didn't mention a target vertex...

It actually finds the distance from s to **every** other vertex. The resulting edges are called **the shortest path tree**.

All our shortest path algorithms have this property.

If you only care about one target, you can sometimes stop early (in `bfsShortestPaths`, when the target pops off the queue)

```

Map<V, E> bfsFindShortestPathsEdges(G graph, V start) {
    // stores the edge `E` that connects `V` in the shortest path from s to V
    Map<V, E> edgeToV = empty map

    // stores the shortest path length from `start` to `V`
    Map<V, Double> distToV = empty map

    Queue<V> perimeter = new Queue<>();
    Set<V> discovered = new Set<>();

    // setting up the shortest distance from start to start is just 0 with
    // no edge leading to it
    edgeTo.put(start, null);
    distTo.put(start, 0.0);

    perimeter.add(start);

    while (!perimeter.isEmpty()) {
        V from = perimeter.remove();
        for (E e : graph.outgoingEdgesFrom(from)) {
            V to = e.to();
            if (!discovered.contains(to)) {
                edgeTo.put(to, e);
                distTo.put(to, distTo(from) + 1);
                perimeter.add(to, newDist);
                discovered.add(to)
            }
        }
    }
    return edgeToV;
}

```

This is an alternative way to implement bfsShortestPaths that has an easier time accessing the actual paths / distances by using Maps

