

DESIGN OF DIGITAL CIRCUITS AND SYSTEMS

Communication

Instructor: Justin Hsia

Teaching Assistants:

Colton Carroll

Hemil Patel

Rasya Fawwaz

Grace Zhou

Quinlyn Donohue

Rose Maresh

Relevant Course Information

- ❖ Homework 5 due tomorrow

- ❖ Lab 5 due next week (5/22)
 - Hardest/longest lab
 - You will need to use the VGA interface on LabsLand

- ❖ Quiz 4 next Thursday (5/21)
 - Algorithm to Hardware – ASMD and datapath drawing
 - 40 minutes

Mid-Quarter Survey Feedback

- ❖ Workload distribution centered around 14-15 hr
- ❖ Bigger, neater handwriting on slides, please
- ❖ Lectures can feel fast at times
- ❖ Wish for some later OHs, more flexibility with demo times
- ❖ Lab demos are conversational, not intimidating
- ❖ More transparency from the autograders would be appreciated
- ❖ Wish we could have physical FPGAs

Disclaimers

- ❖ This topic (communication) won't be used on any assignment this quarter
- ❖ It encompasses both FPGAs and computers and some analog considerations, but is definitely relevant to digital design
 - Could test/build communication drivers on FPGAs, but often included in microcontrollers
 - For more, take EE/CSE 474: Embedded Systems

Communication

- ❖ “The transmission, reception, and processing of information between two or more locations with the use of electronic circuits.”
 - Includes a lot more than what we’ve discussed so far
 - Want this to be *general* so you don’t have to build custom circuits (like the CDC ones we saw) for every use
 - However, many communication schemes are/were created for specific applications

- ❖ The goal for today is to introduce you to communication considerations via examples

Aside: LabsLand

- ❖ Made possible by communication between the DE1-SoC, a Raspberry Pi Pico, and a Raspberry Pi Server:

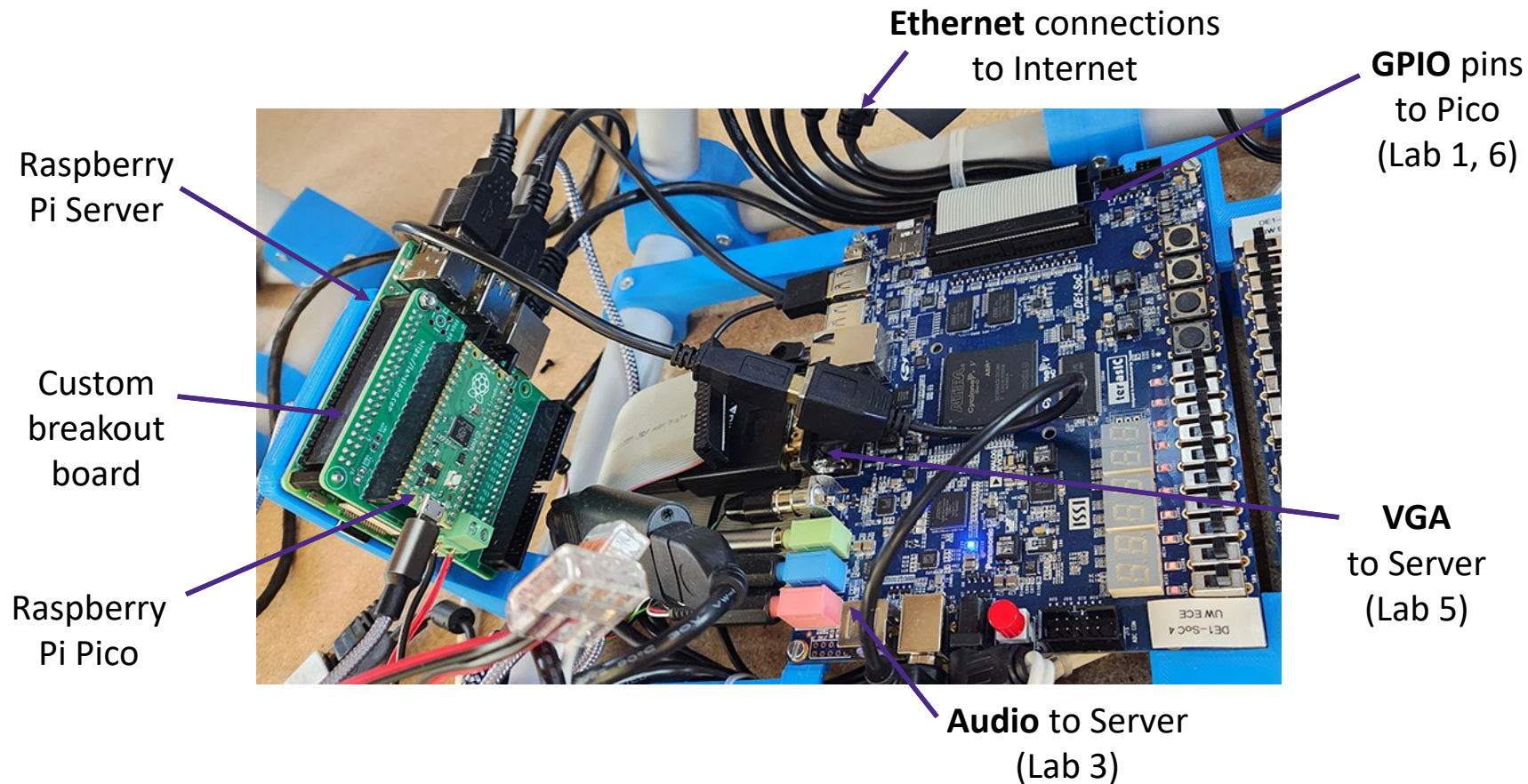

Communication Considerations

- ❖ **Bandwidth:** Number of wires and what mix of serial/parallel
- ❖ **Speed:** Bits/bytes/words per second
 - Baud (Bd) is the unit for symbol changes per second
- ❖ **Timing methodology:** Synchronous or asynchronous
- ❖ **Number of devices:** Sources and destinations
 - **Arbitration scheme:** Daisy-chain, centralized, distributed
- ❖ **Protocols:** Provide some guarantees as to correctness, may include error detection or correction

Serial vs. Parallel Communication (1/2)

- ❖ **Serial communication** involves sending *data* over a single wire, separated in time
 - Often includes other wires for *control signals*

- ❖ **Parallel communication** involves sending multiple bits of data simultaneously over multiple wires

- ❖ Discuss with your neighbor(s):
 - Which type do you think is more prevalent in computer systems and why (pros/cons)?

Serial vs. Parallel Communication (2/2)

- ❖ **Serial** is actually more common in modern systems!
 - **Fewer wires** required → less costly, less power, less space, no clock skew



- High switching speeds leads to **crosstalk in parallel data bits** → serial can do longer distances and higher transmission speeds (*i.e.*, clock rate, not necessarily data rate)
 - However, serial requires more **processing** to convert between serial and parallel form
- ❖ **Parallel** found within ICs and computer systems (system, memory, and hard drive busses) or specialized devices (*e.g.*, older printer ports)

Timing Methodology

- ❖ Analogous to our clock domain crossing discussion!
- ❖ **Synchronous:** Clock signal is sent along one of the communication wires
 - Recall: *Known* relationship between clock signals
- ❖ **Asynchronous:** Clock signal is not sent
 - Recall: *Unknown* relationship between clock signals
 - Open-loop solutions typically involves oversampling by the receiver
 - Closed-loop solutions include the various synchronizers previously discussed

Number of Devices

- ❖ Single source – single destination
 - Easy and cheap (point-to-point, no tri-stating necessary)

- ❖ Single source – multiple destination
 - Physical fanout limitations
 - Need an addressing scheme to direct data to particular destination

- ❖ Multiple source – multiple destination
 - With multiple potential drivers, need tri-stating as well as collision detection
 - Fairness considerations (*e.g.*, priority scheme, arbitration between senders)

Some Serial Communication Schemes

- ❖ UART
 - Usually asynchronous, point-to-point
- ❖ SPI
 - Synchronous, single source – single destination
- ❖ I2C
 - Synchronous, single source – multiple destination
- ~~❖ USB~~
- ~~❖ Ethernet~~
 - Multiple source – multiple destination

UART

❖ Universal Asynchronous Receiver-Transmitter

- Hardware device that implements this asynchronous serial communication *interface* (electrical details missing)
 - UART is usually part of a microcontroller chip alongside an external driver circuit that converts the UART output to a specific standard (*e.g.*, RS-232)
- Configurable *serial frame*:
 - Transmission speed (*e.g.*, 9600 baud)
 - Data format:

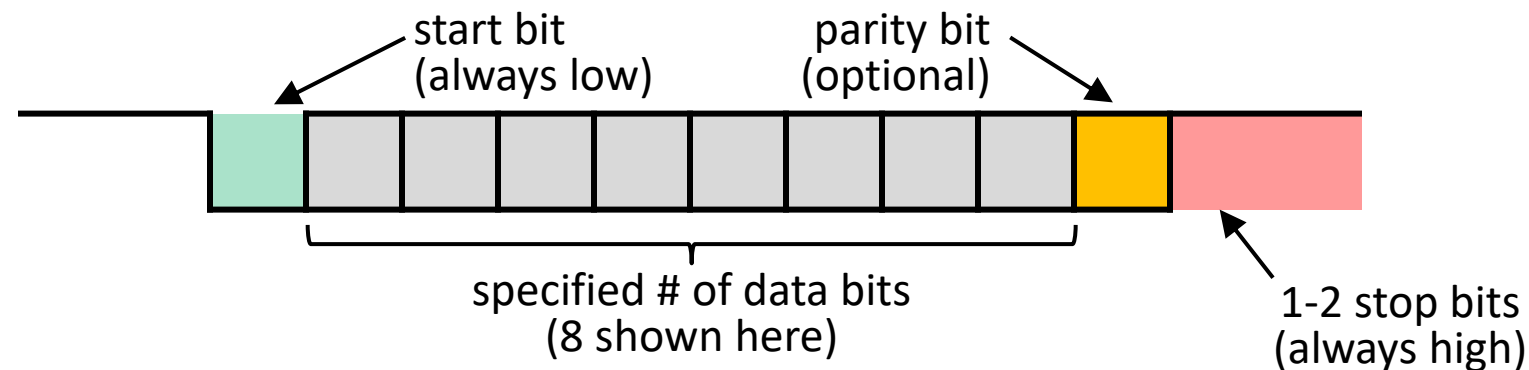

UART Details

- ❖ TX and RX signals, possibly used simultaneously
 - Simplex, half duplex, full duplex
- ❖ Internal clock must run faster than baud rate
 - Typically 8–16x
 - Data bits are sampled at expected “middle”:

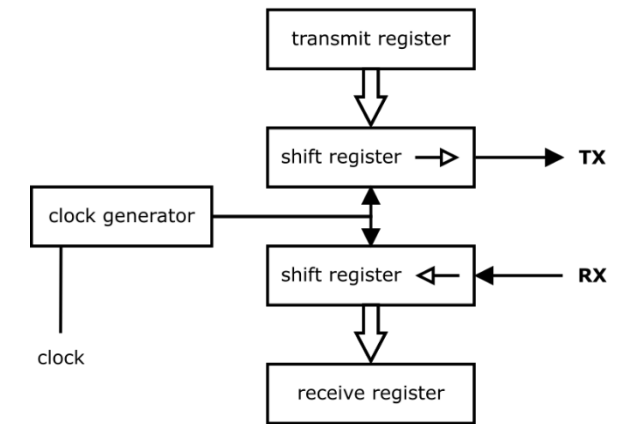
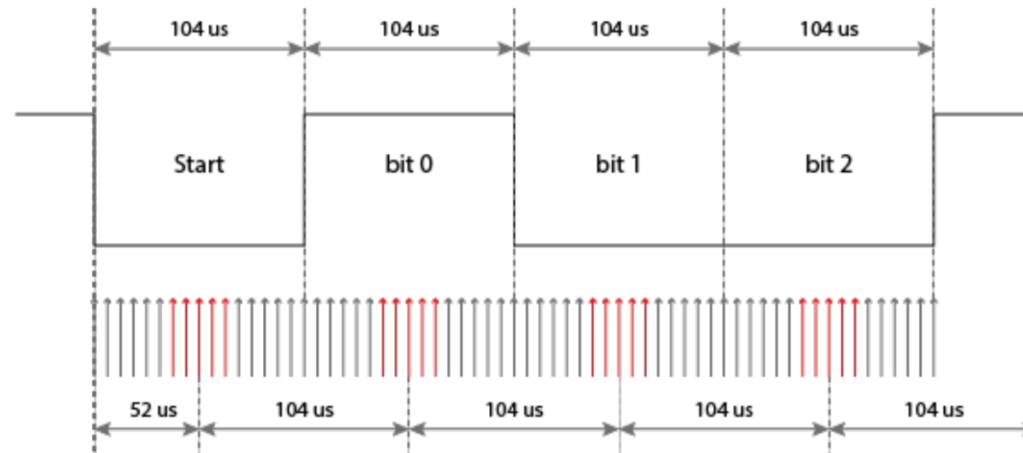

- ❖ Receiver and transmitter must have the same settings to avoid errors

DE1-SoC UART Receiver Design

❖ Design notes:

- Data: input is serial, output is parallel (assume 8 bits/frame)
- DE1 running on CLOCK_50, but the UART receiver must account for variable baud rate
- Want to sample in the *middle* of each data bit

❖ Design questions (datapath):

- What digital component will help us *convert from serial to parallel*?
- If the desired transmission rate is X Hz, which digital components can help us decide when to sample?

DE1-SoC UART Receiver Block Diagram

- ❖ Assume we are oversampling by 8x
- ❖ Inputs: `clk`, `reset`, `data_in`
- ❖ Outputs: `data_out`

DE1-SoC UART Receiver State Diagram

- ❖ Assume 8 data bits, no parity bit, 1 stop bit
- ❖ Inputs: reset, sampled_bit
- ❖ Outputs: in_frame

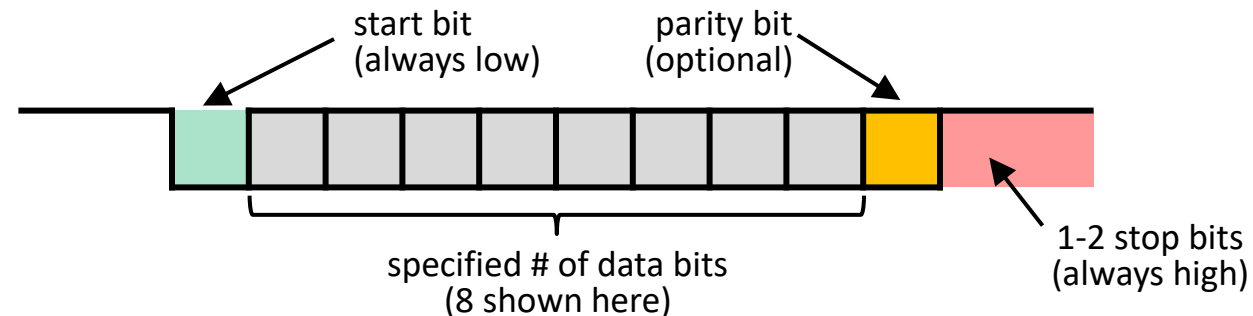

Aside: LabsLand UART

- ❖ In Lab 6, you have the option of using two serial UART peripherals in LabsLand: N8 controller and joystick
 - Uses provided `serial_driver.sv` on one of the GPIO pins to talk to the Pico

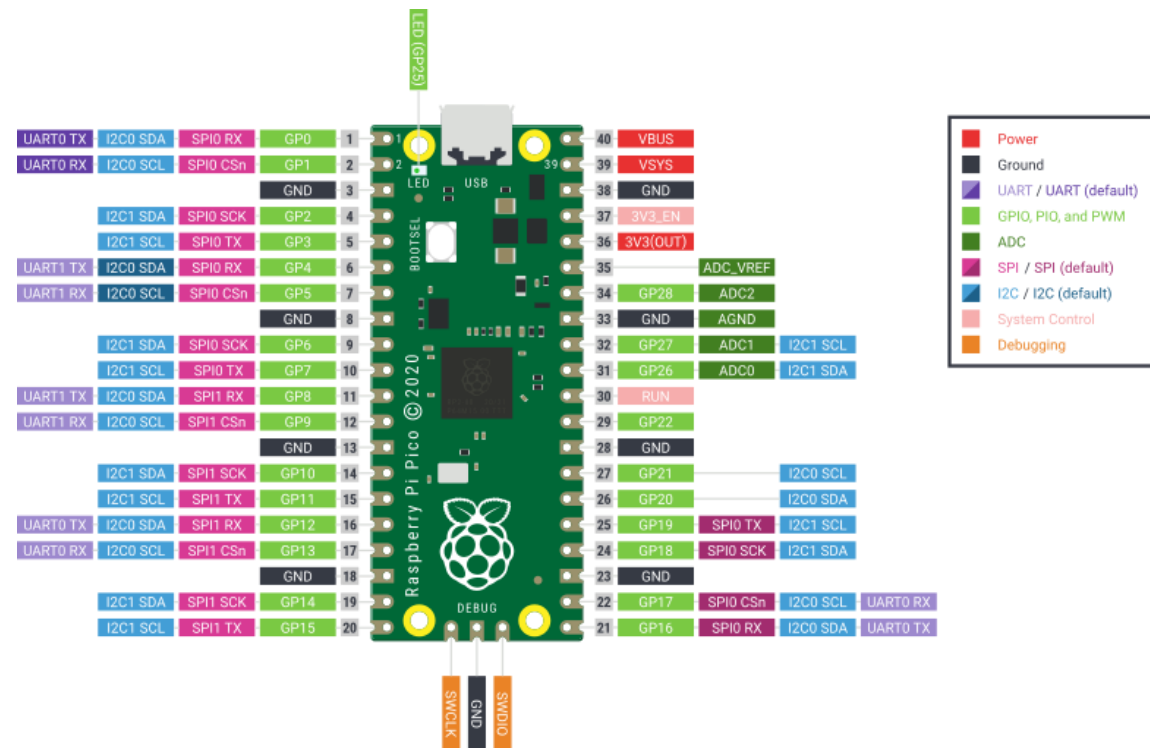

serial_driver.sv Notes

- ❖ SPEED is related to baud/transmission rate
 - count/counter form the slow clock
 - Constantly receiving data – arbitrary wait before next read
- ❖ MAX_STEPS accounts for serial frame configuration
 - latch triggers request to Pico
 - pulse, latch are used to sample/shift
 - save is when save data (end of frame)

count	0	1	2	3	4	5	6	7	8	9	10	11	12	13	14	15	16	17	18	19
latch	0	1	1	0	0	0	0	0	0	0	0	0	0	0	0	0	0	0	0	0
pulse	0	0	0	0	1	0	1	0	1	0	1	0	1	0	1	0	1	0	1	0
save	0	0	0	0	0	0	0	0	0	0	0	0	0	0	0	0	0	0	0	1

TECHNOLOGY

BREAK

Communication Terminology Note

- ❖ The following communication schemes have historically used the term “master” to describe a device that controls one or more “slaves”
 - This can be a problematic metaphor, particularly in the context of historical race relations in the United States
 - It can also be an inaccurate metaphor, as often the “master” device does not actually have a real control relationship over the “slave” device(s) or they may be swappable
 - More info: <https://muse.jhu.edu/article/215390/>
- ❖ Here, we will use proposed replacement names
 - Not uniformly accepted – there is plenty of current debate around naming

SPI

Serial Peripheral Interface

- A synchronous serial interface between one *controller* and one (of possibly many) *peripherals*
 - Requires ≥ 4 wires (as opposed to UART's 2)
 - SCK = serial clock, PICO = peripheral in/controller out, POCI = peripheral out/controller in, \overline{CS} = chip select (active low)

- Full duplex data transfer initiated by controller on a negative edge of the peripheral's chip select
 - Occurs one *word* (e.g., 8 bits) at a time, even if one party isn't sending that much

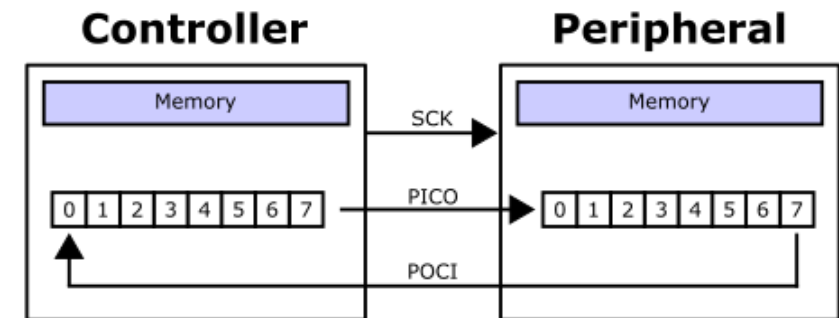
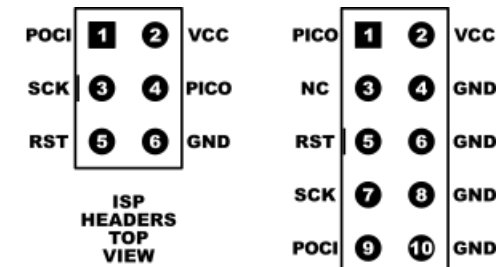
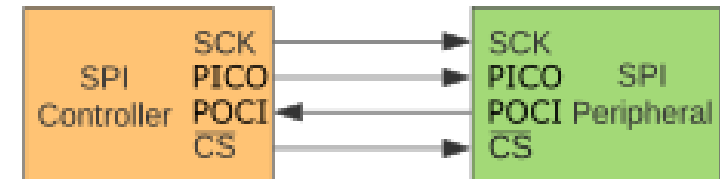

SPI Details

- ❖ We don't need to oversample values, but still want to read them in the middle
 - Defined modes based on **clock polarity** (CPOL) and **clock phase** (CPHA)
 - CPOL determines the “idling” state of the clock and which edges are considered *leading vs. trailing*
 - CPHA determines which edges are for data changes and which edges are for data capture
 - This means that we can typically run SPI at a faster rate than UART!

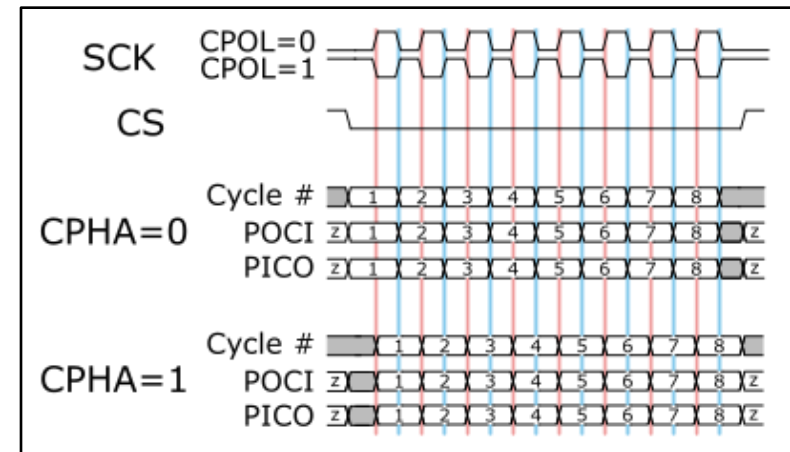

SPI Configurations

- ❖ Not great for communicating with multiple peripherals:

Independent Selection

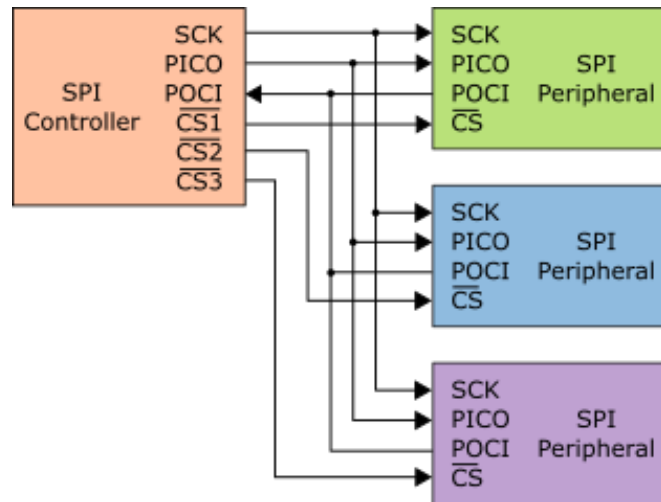

- Requires one chip select per peripheral
- Requires tri-stating
- Non-selected must ignore PICO and POCI signals

Daisy Chain

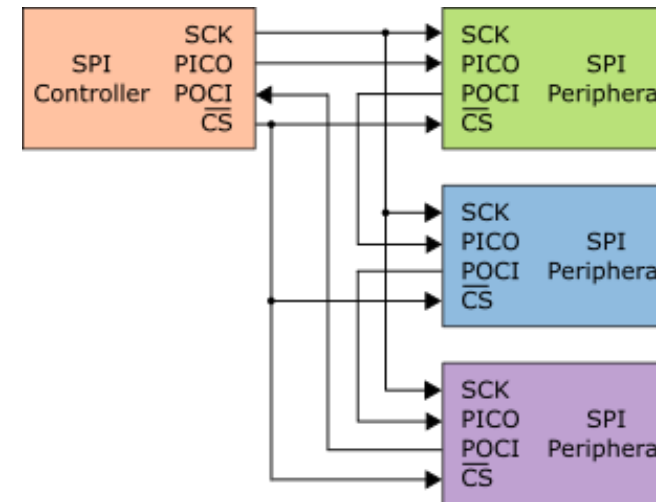

- Single chip select line needed
- Whole chain acts as a communication shift register
- A less common configuration

I²C/I2C

❖ Inter-Integrated Circuit Bus

- A synchronous serial interface between one *controller* and many *targets*
 - Only requires 2 lines (same as UART), but bidirectional and half duplex
 - SDA = serial data line, SCL = serial clock line
 - Pull-up resistors create “open drain” bidirectional I/O:
- Can be used with many types of devices/targets
 - *e.g.*, μ controllers, sensors, ADCs/DACs, memory modules, LCD drivers, real-time clocks
- Communications always initiated by controller, but both controller and target can send and receive data on SDA
 - More difficult to manage (more on this next)
 - Communications include *acknowledgement*

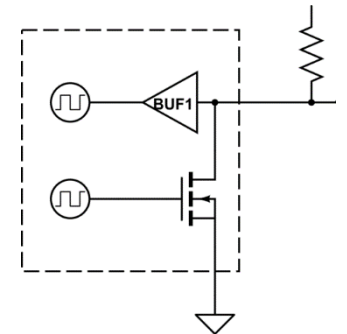
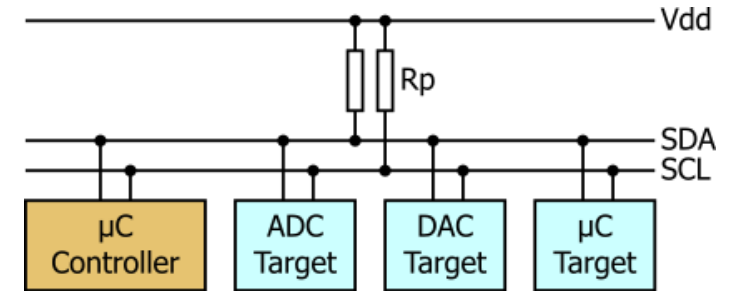
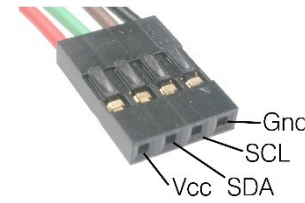

I²C/I2C Details (1/2)

- ❖ Communications bookended by special (2-wire) **START** and **STOP** signals:
 - While SCL is high: START is SDA to low; STOP is SDA to high
 - Other “START” signals are ignored until STOP is seen
- ❖ SDA values changed on **leading edges of clock** and read on **trailing edges of clock** (like SPI)
- ❖ Every N bits (usually 8) is followed by an ACK (0) or NACK (1) sent by the *receiver*
 - Communications on SDA switches directions for this bit

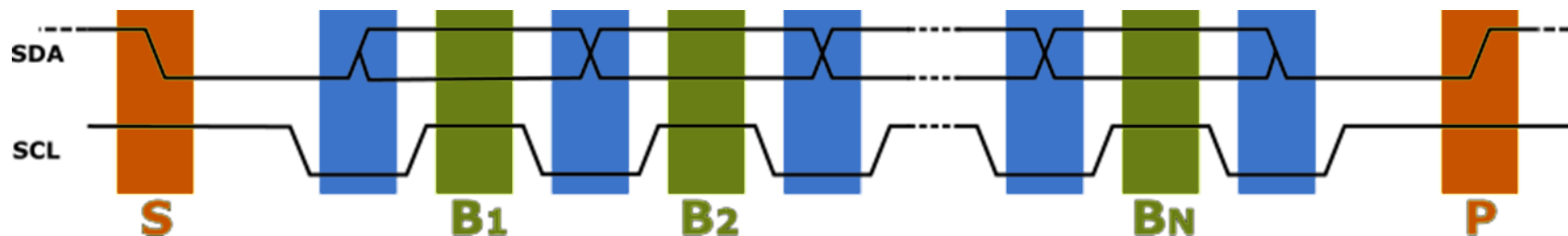

I²C/I2C Details (2/2)

- ❖ Everything is listening on the same SDA, so how to differentiate?
 - First byte contains **7-bit address** followed by R/W bit; targets with different addresses will ignore this communication
 - 16 reserved addresses, so max of 112 targets
 - Actually possible to have multiple controllers on the same SDA line, so need an *arbitration scheme* in case multiple controllers start a communication at the same time
 - First controller to notice ground when trying to send a “1” stops

- ❖ Limited range because of bus capacitance and need for a common ground potential

Serial Communication Review Questions

❖ Which serial communication scheme(s):

- Has the most limited communication range?

UART SPI I²C

- Is not fully duplex?

UART SPI I²C

- Works best with multiple destinations?

UART SPI I²C

- Can have the fastest transmission rate?

UART SPI I²C

VGA

❖ Video Graphics Array

- Developed for cathode ray tube (CRT) displays, which scan across the monitor left-to-right and top-to-bottom
 - Data sent sequentially pixel-by-pixel, but this is **parallel communication** because each pixel contains red, green, and blue (RGB) data simultaneously
 - The electron guns need to reposition at the end of each row and frame
- Is a very confusing graphics standard, as it allows for different resolution, color, and timing specifications (with varying amounts of forgiveness on different monitors)

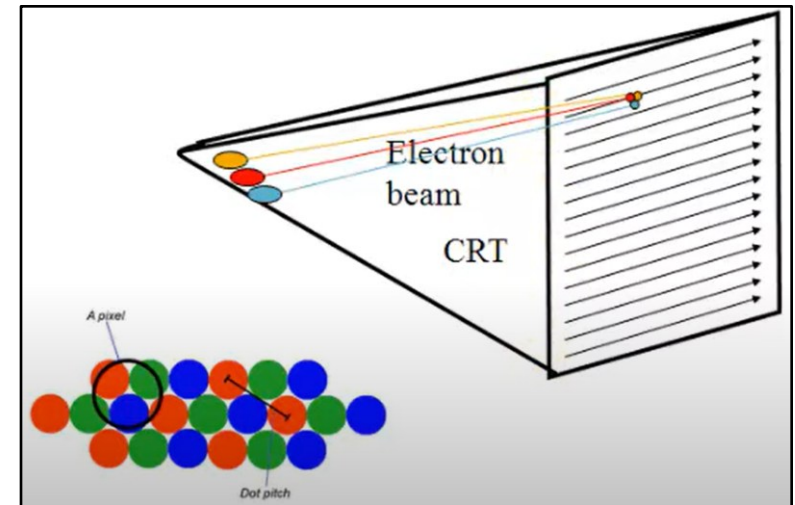

VGA Screen

- ❖ The screen is not what you think!
 - Up to 640 x 480 pixels in drawing area, but surrounded by front and back porches
 - Pixel clock cycles through different pixel data during drawing area
 - Horizontal and vertical sync signals pulse to trigger reset at end of row and frame, respectively

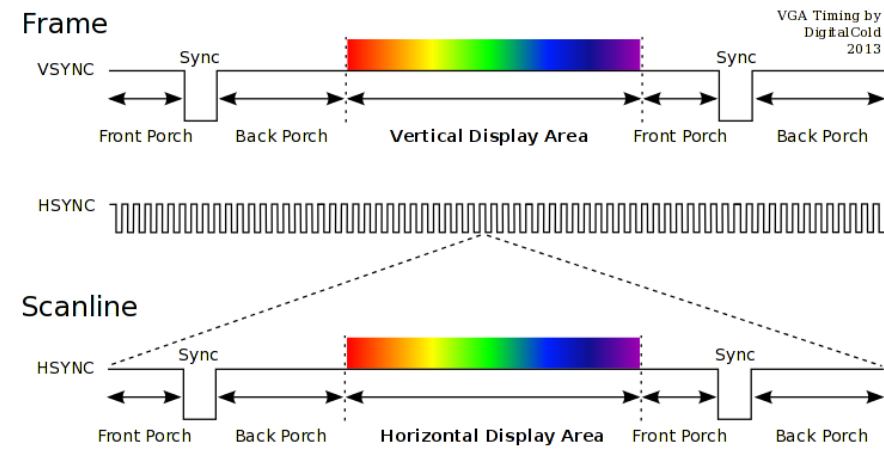
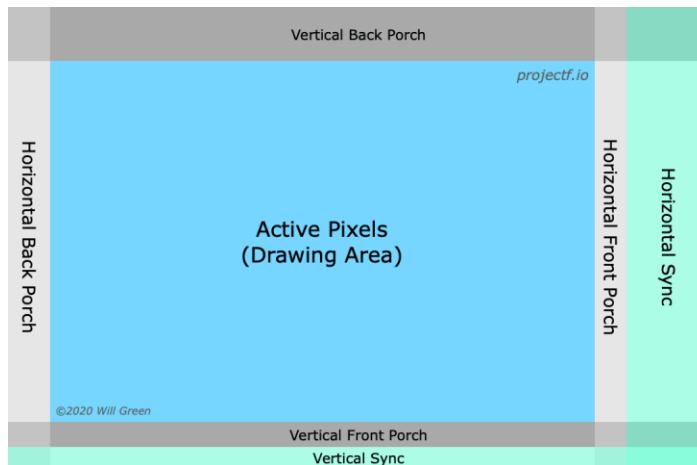

VGA Details

- ❖ The pinout is analog:

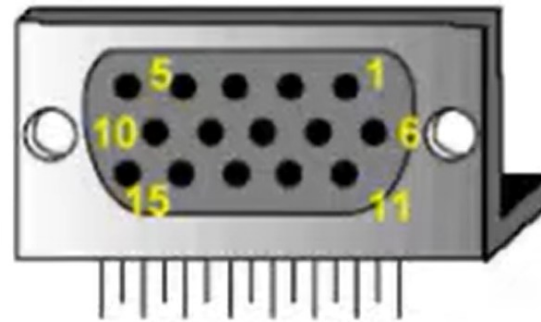

Pin 1: Red	Pin 5: GND
Pin 2: Grn	Pin 6: Red GND
Pin 3: Blue	Pin 7: Grn GND
Pin 13: HS	Pin 8: Blu GND
Pin 14: VS	Pin 10: Sync GND

- Lines up mostly with the outputs of the VGA_framebuffer module:

* VGA_R	- Red data of the VGA connection
* VGA_G	- Green data of the VGA connection
* VGA_B	- Blue data of the VGA connection
* VGA_CLK	- VGA's clock signal
* VGA_HS	- Horizontal Sync of the VGA connection
* VGA_VS	- Vertical Sync of the VGA connection
* VGA_BLANK_n	- Blanking interval of the VGA connection
* VGA_SYNC_n	- Enable signal for the sync of the VGA connection