

DESIGN OF DIGITAL CIRCUITS AND SYSTEMS

Algorithms to Hardware I

Instructor: Justin Hsia

Teaching Assistants:

Colton Carroll

Grace Zhou

Hemil Patel

Quinlyn Donohue

Rasya Fawwaz

Rose Maresh

Relevant Course Information

- ❖ Lab 3 reports due Friday (5/1)
- ❖ Lab 4 due next Friday (5/8)
- ❖ Homework 4 due on Monday (5/4)
- ❖ Anonymous mid-quarter survey on Canvas (due 5/4)
- ❖ Quiz 3 (ASM, ASMD) next Thursday (5/7)

Arithmetic Mean: Pseudocode

- ❖ Design a sequential circuit that computes the mean M of k n -bit numbers stored in registers
 - *e.g.*, accessing a RAM or register file with k addresses
 - To save on hardware, only use one n -bit adder and have a single read port RAM
- ❖ Algorithm Pseudocode:

Arithmetic Mean: Specification

❖ Datapath

- A k -address *register file* (only using `r_addr` and `r_data`)
- Reg file address stored in $\lceil \log_2(k) \rceil$ *down-counter* A
- Sum stored in register S
- An n -bit *divider* circuit, as discussed last lecture

❖ Control

- Inputs *Start* and *Reset*, outputs *Ready* and *Done*
- Status signals:
- Control signals:

Arithmetic Mean: Initial ASMD Chart

- ❖ For now, ignore the details of the divider circuit (assume it takes 1 cycle)

Arithmetic Mean: Modified ASMD Chart

- ❖ Fix your ASMD chart based on the divider circuit:

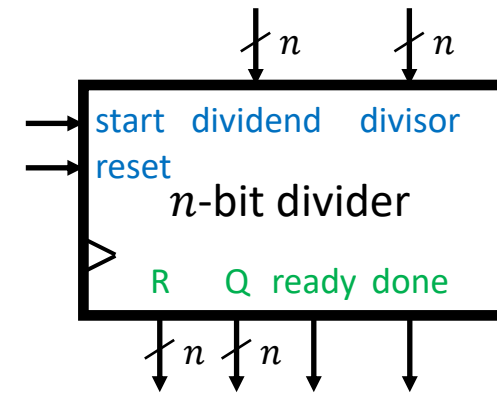

Arithmetic Mean: Datapath

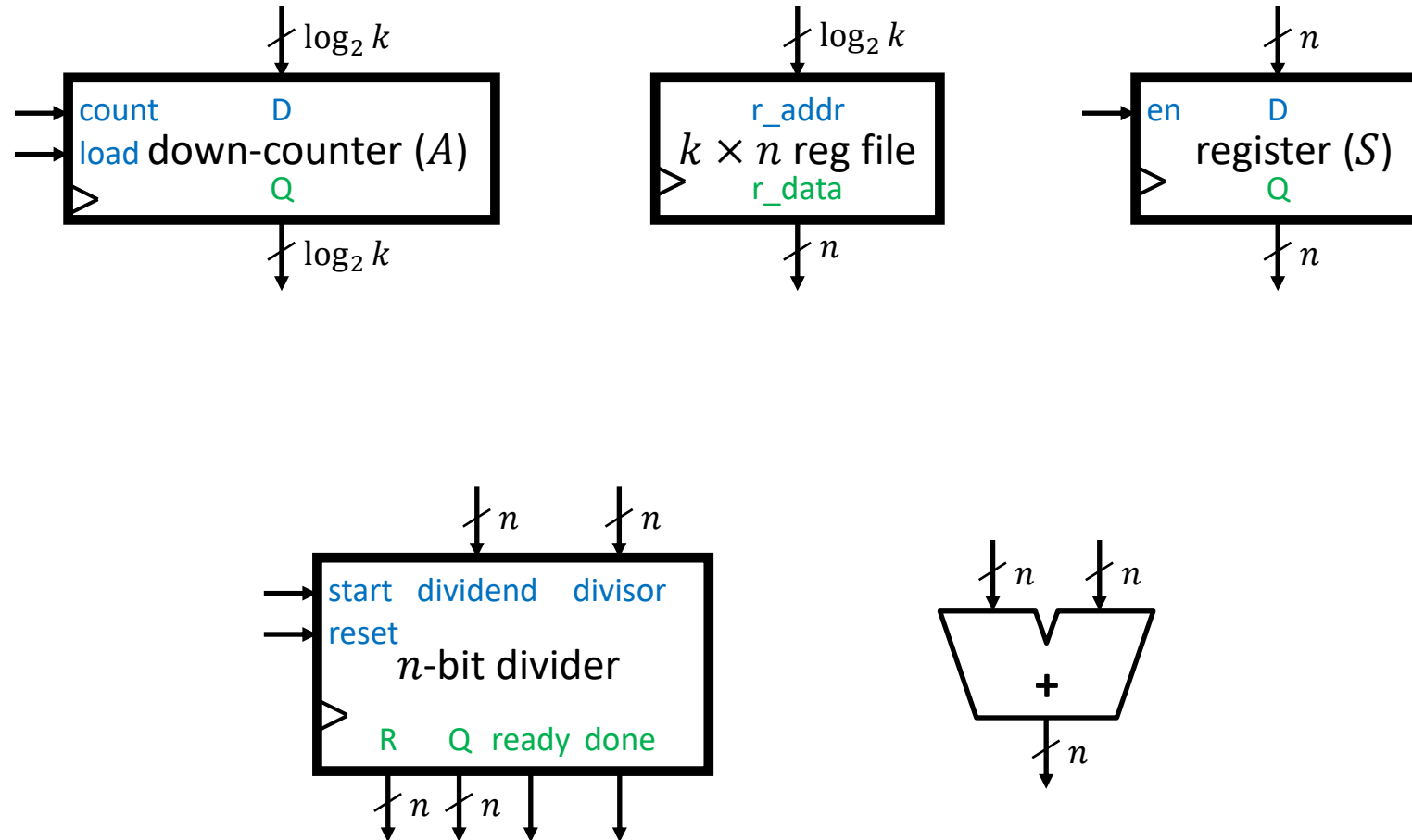

TECHNOLOGY

BREAK

Aside: Load Loops

- ❖ For *some* initialization operations, you can get equivalent behavior from either the (1) outgoing edge or the (2) looping edge:

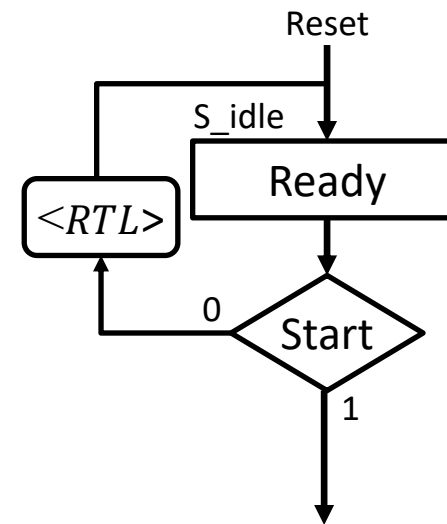
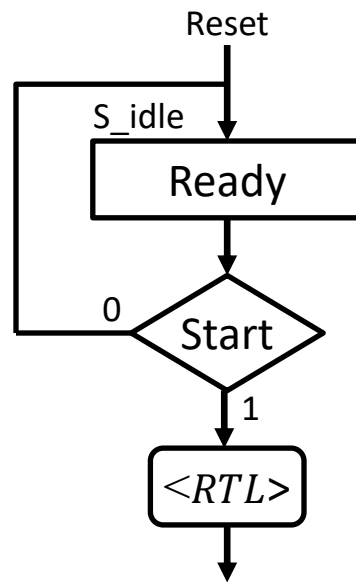

Aside: Start Loops

- ❖ What happens if we forget to de-assert *Start*?

- ❖ Fix:

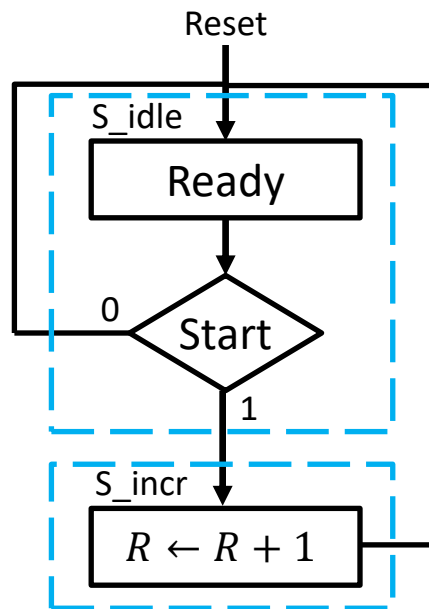

Sorting Algorithm

- ❖ Design a circuit to sort k n -bit numbers stored in a set of registers in ascending order

Algorithm:

```
for i = 0 to k-2 do
  A = Reg[i]
  for j = i+1 to k-1 do
    B = Reg[j]
    if B < A then
      Reg[i] = B
      Reg[j] = A
      A = Reg[i]
    endif
  endfor
endfor
```

Example ($k = 4$):

i	j	A	B	R[0]	R[1]	R[2]	R[3]
0	1	3	7	3	7	1	0

Sorting Algorithm: Specification

❖ Datapath

- A k -address *register file* (assume only 1 port)
- Two $\lceil \log_2(k) \rceil$ *up-counters* i and j
- Two registers A and B
- An n -bit *comparator* circuit to check for $B < A$

❖ Control

- Inputs *Start* and *Reset*, outputs *Ready* and *Done*
- Status signals:
- Control signals:

Sorting Algorithm: Timing Notes

❖ Datapath

- A k -address *register file* (assume only 1 port)
- Two $\lceil \log_2(k) \rceil$ *up-counters* i and j
- Two registers A and B
- An n -bit *comparator* circuit to check for $B < A$

❖ Timing Notes:

- RTL operations in a state occur on the *next* clock trigger
- Can $i \leftarrow x$ and $A \leftarrow \text{Reg}[i]$ be done simultaneously?
- Can $\text{Reg}[i] \leftarrow B$ and $\text{Reg}[j] \leftarrow A$ be done simultaneously?
- Swap operations *must* be done sequentially

Sorting Algorithm: ASMD Chart

Sorting Algorithm Datapath

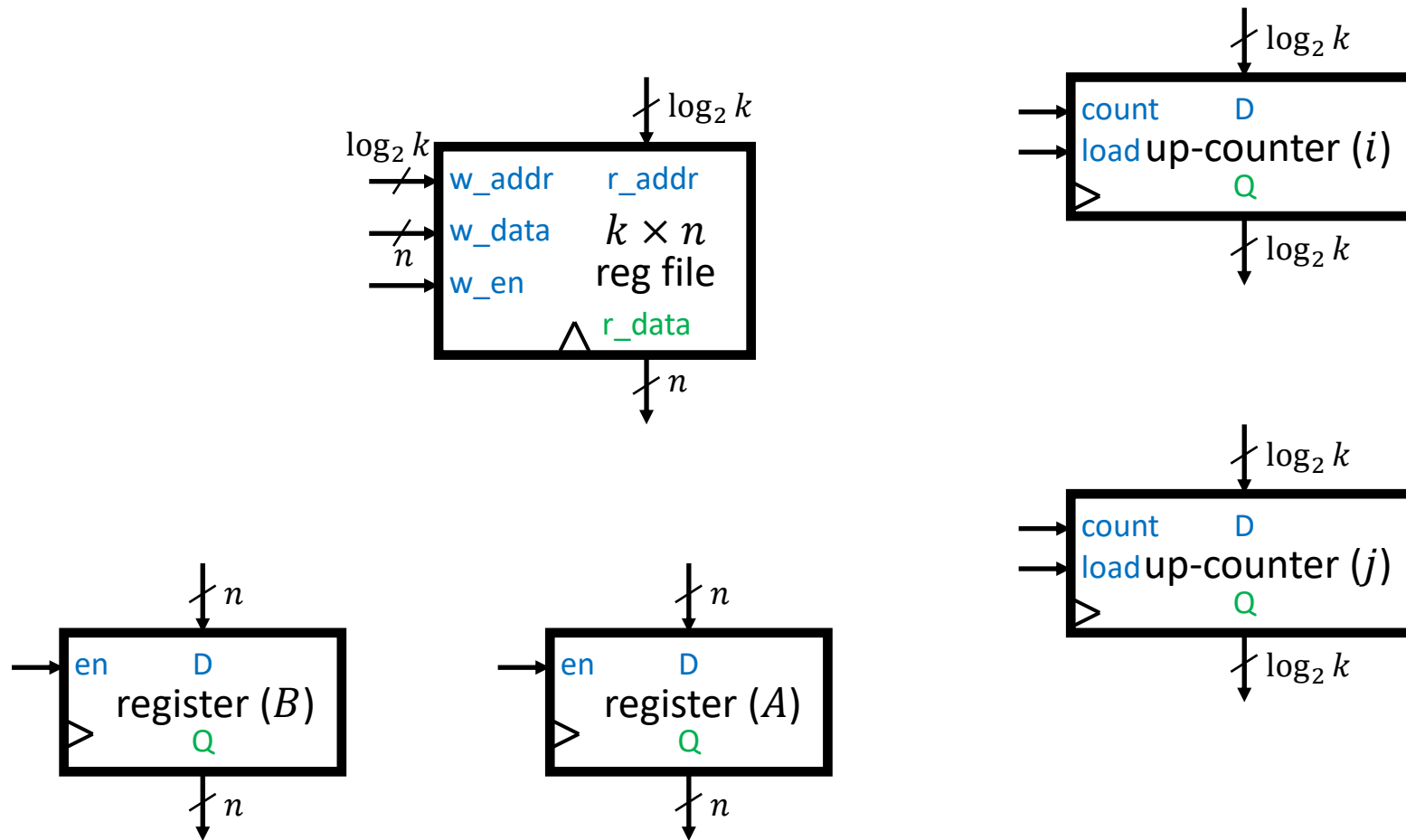

Alternate Sort Algorithm Datapath

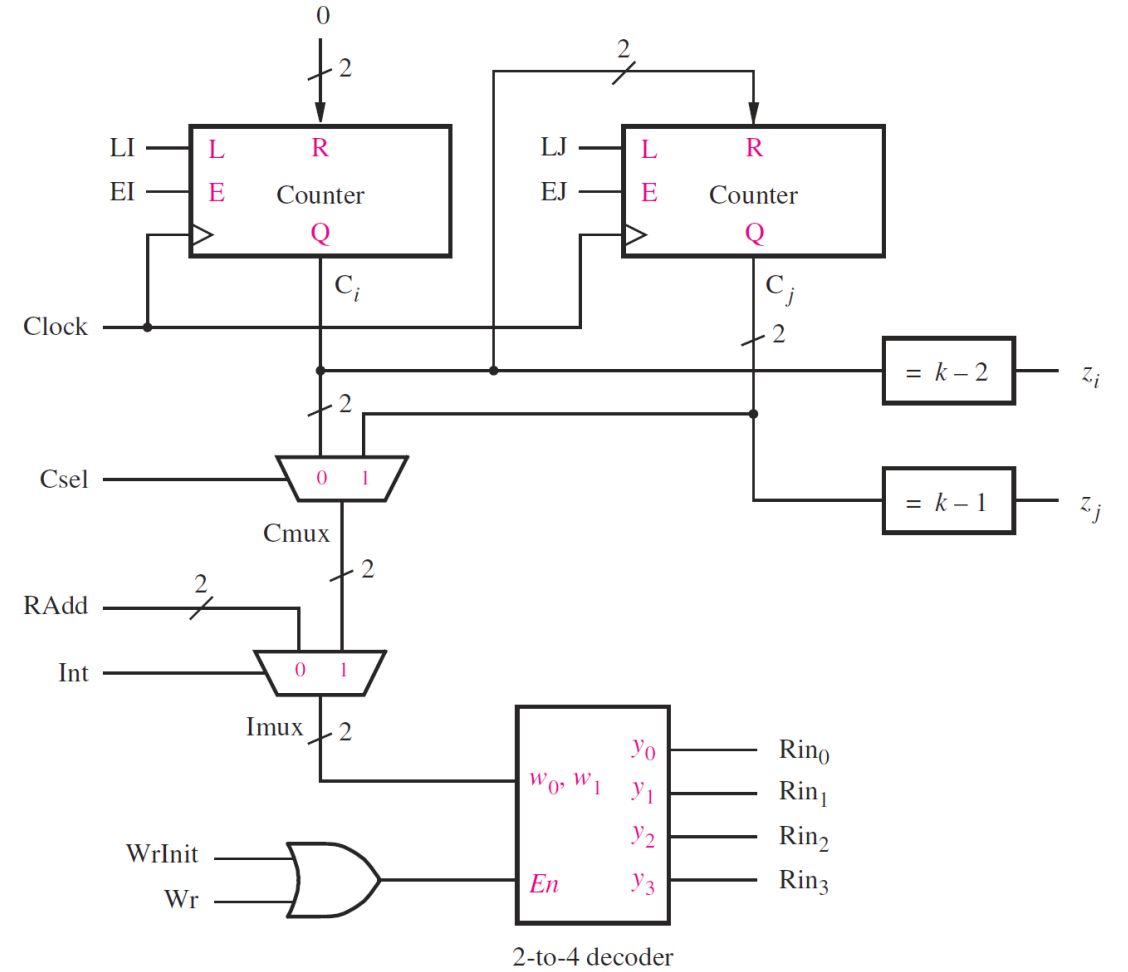
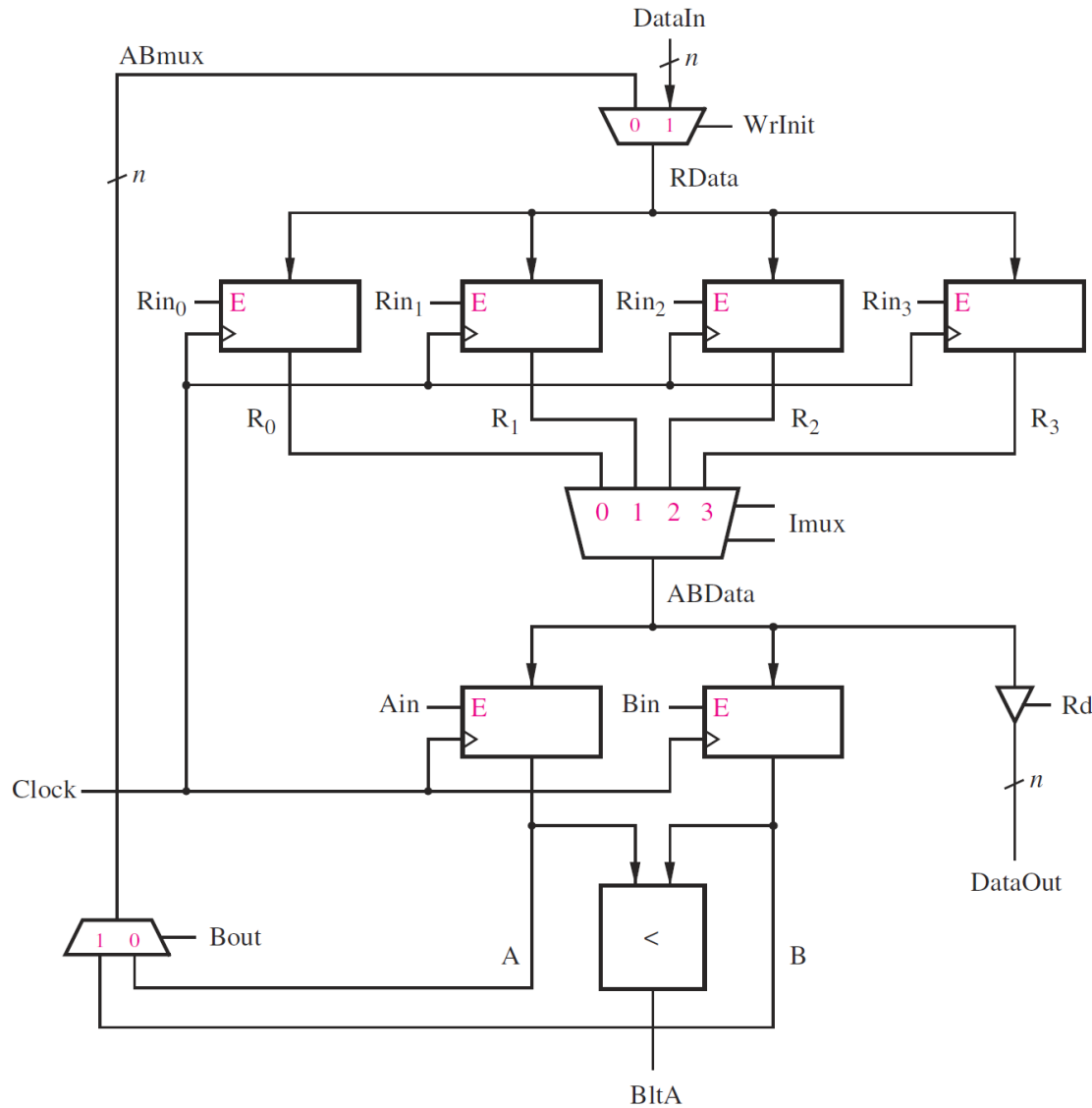

Lab 4 Preview: Binary Search

- ❖ Design a circuit that searches a *sorted* array for a given value by checking the middle element of the remaining portion of the array we would expect to find the given number:

```
L = 0
R = n - 1
while L <= R do
  m = floor((L + R)/2)
  if A[m] < T then
    L = m + 1
  else if A[m] > T then
    R = m - 1
  else
    return m
  endif
endwhile
return unsuccessful
```