

# DESIGN OF DIGITAL CIRCUITS AND SYSTEMS

## Algorithmic State Machines

**Instructor:** Justin Hsia

**Teaching Assistants:**

Colton Carroll

Hemil Patel

Rasya Fawwaz

Grace Zhou

Quinlyn Donohue

Rose Maresh

# Relevant Course Information

- ❖ Homework 2 due Wednesday (4/15)
- ❖ Homework 3 released today, due next Friday (4/24)
  
- ❖ Lab 2 reports due 4/17, demos 4/20-24
- ❖ Lab 3 released today, due in two weeks (5/1)
  - Lab 3 + 4 are really ~1.5 weeks long, so don't wait!
  
- ❖ Quiz 2 not until *next* Thursday (4/23)
  - Spacing between material and quiz will get longer and longer; make sure to give time to review

# Lab 3 Notes (1/2)

- ❖ More practical **applications of memory** on the DE1-SoC using **audio generation and filtering**
  - Task 2: ROM with MIF file to generate audio
  - Task 3: Use a FIFO buffer to implement a noise filter
- ❖ See the [Audio Guide page](#) for how to use the LabsLand Audio Interface to send audio input and record audio output:

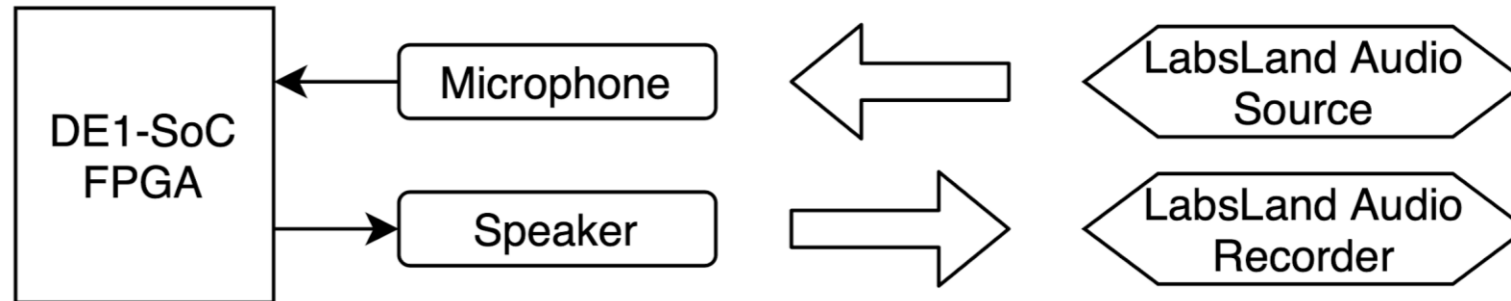

## Lab 3 Notes (2/2)

### ❖ Example of *communication* as you interface with an audio CODEC (coder/decoder)

■ Inputs: read,  
write,  
writedata\_left,  
writedata\_right

■ Outputs: read\_ready,  
write\_ready,  
readdata\_left,  
readdata\_right

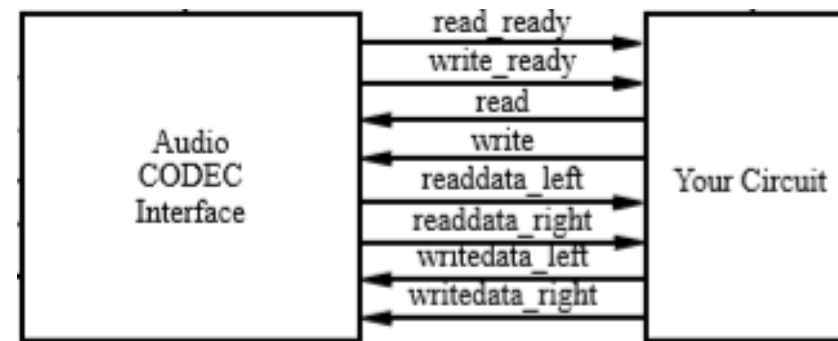

■ **Must wait for both sides (CODEC + your circuit) to be ready for data transmission in either direction!**

- Data is ready/generated AND receiver is ready to accept

# Review Question: Memory Implementation

- ❖ Below is an implementation of a 1-port, 2×8 regfile
  - Currently, when we write to the address we are reading from,  $r\_data$  reflects the current/old data in the register (*i.e.*,  $r\_data \leftarrow regfile[w\_addr]$ )
- ❖ Modify the implementation so that  $r\_data \leftarrow w\_data$  (the new data) in this edge case instead
  - Hint: It may help to write out the Verilog logic before converting to hardware

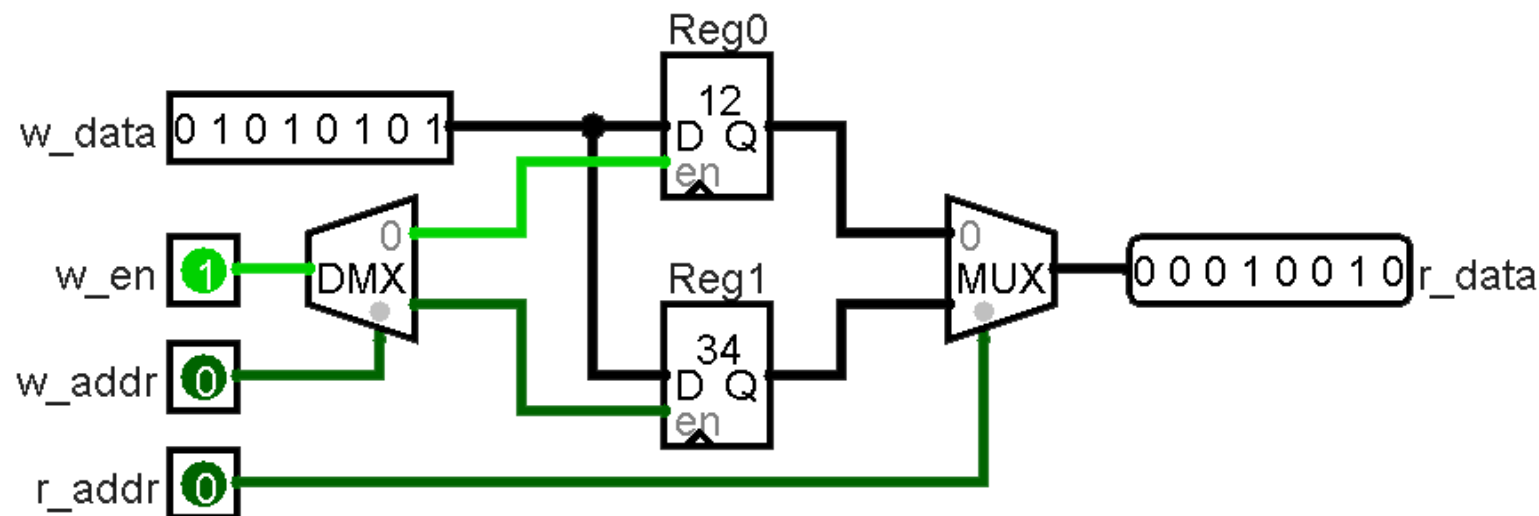

# Memory Implementation Solution

*assign r\_data = ((r\_addr == w\_addr) & w\_en) ? w\_data : (r\_addr ? Reg1 : Reg0);*

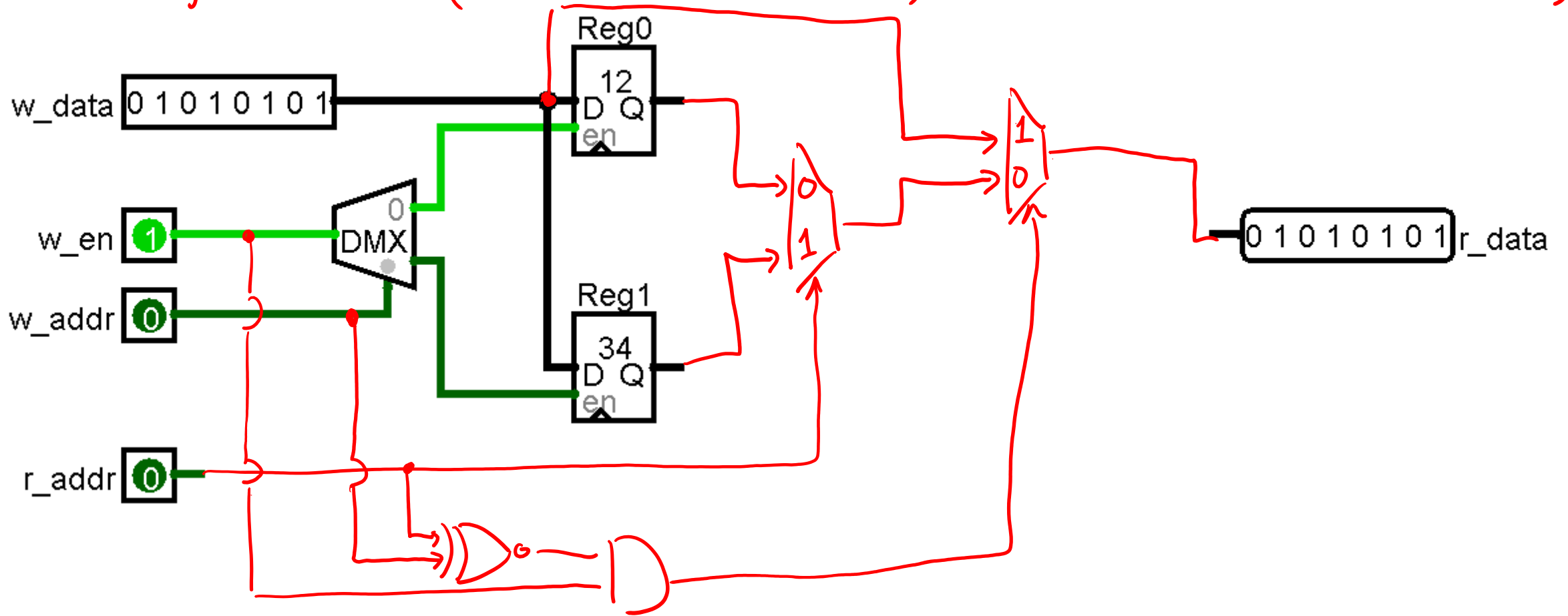

# Specifying Synchronous Digital Systems (SDS)

## ❖ So far:

- SystemVerilog
- Block diagrams
- Finite State Machines
- Circuit/gate diagrams

## ❖ Issues:

- SV is a specified language (rigid syntax) and can be very abstract (behavioral)
- Block diagrams can be vague or unspecified
- FSMs don't scale well (# of states + transitions)
- Gate-level is too detailed and specific

# Algorithmic State Machine (ASM)

- ❖ ASM charts are a method for designing and depicting synchronous digital systems
  - Use more generic syntax (RTL) than SystemVerilog
  - Contain more structured information than FSM state diagrams
- ★ Can more easily design your system from a *hardware algorithm*

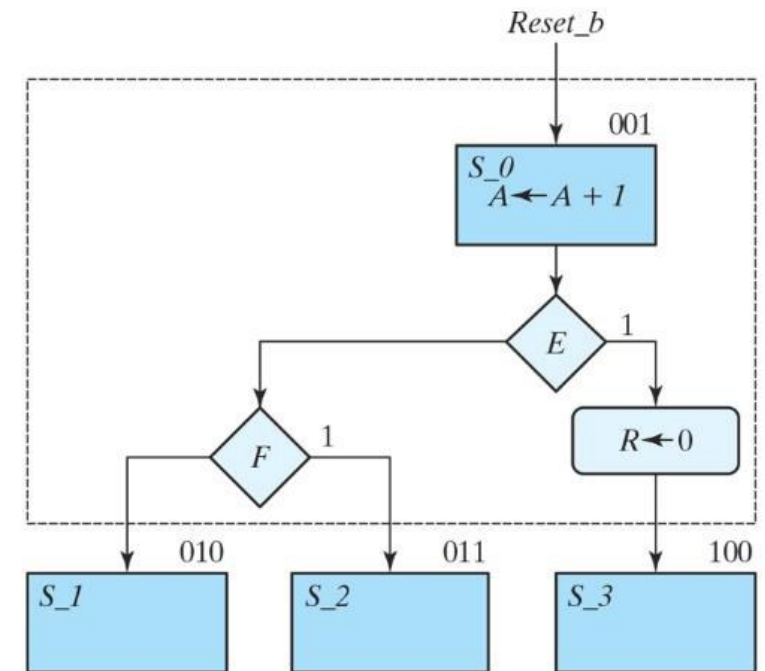

# ASM Chart Components

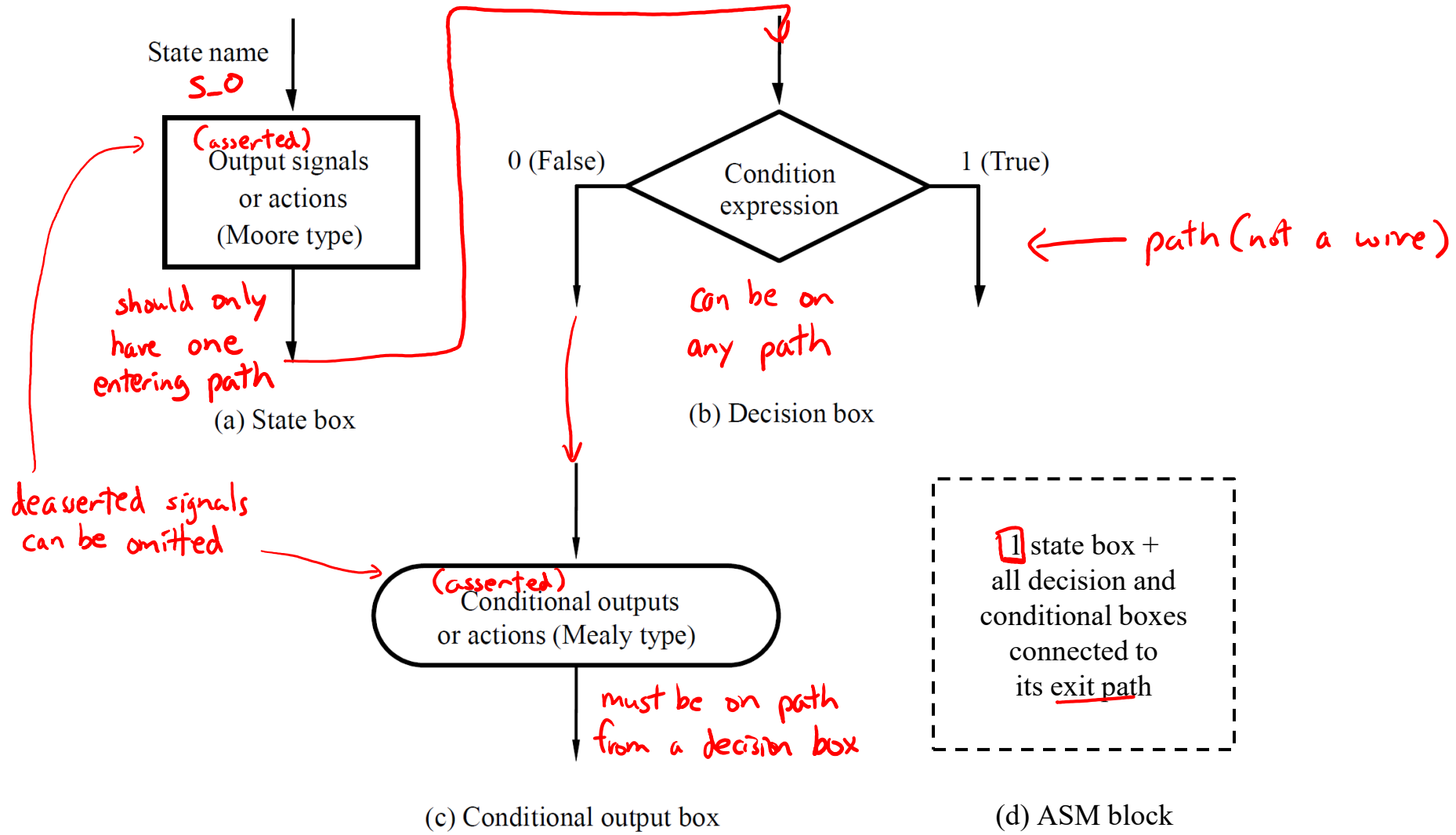

# ASM Blocks

- ❖ Each block describes the state machine operation in a given state
  - For every valid combination of inputs, there must be **exactly one** exit path
  - There should be **no internal feedback**

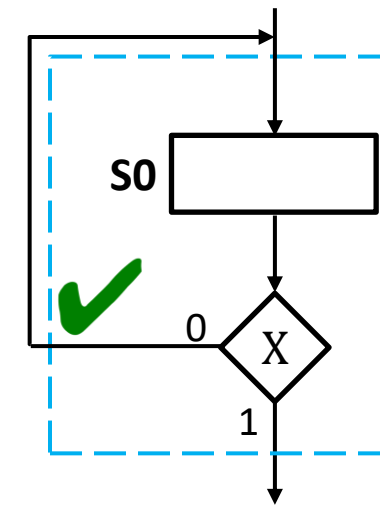
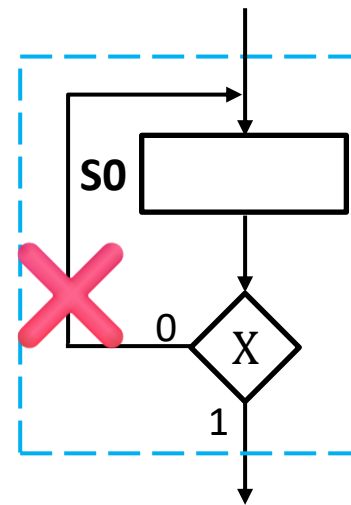
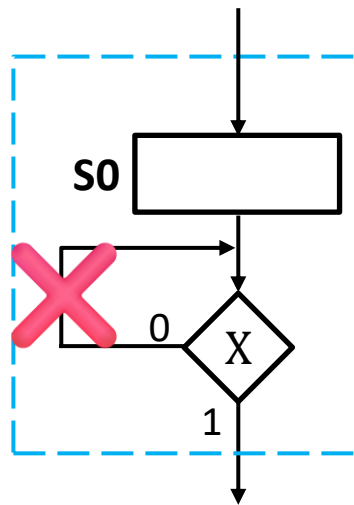

# Worked Example #1

❖ Convert this state machine to an ASM chart:

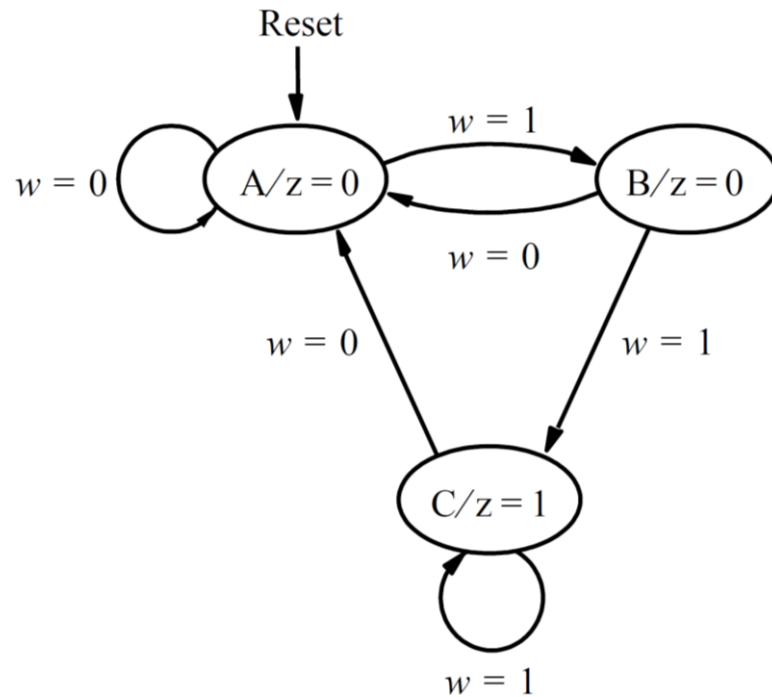

Moore Machine  
 ↳ no conditional output boxes

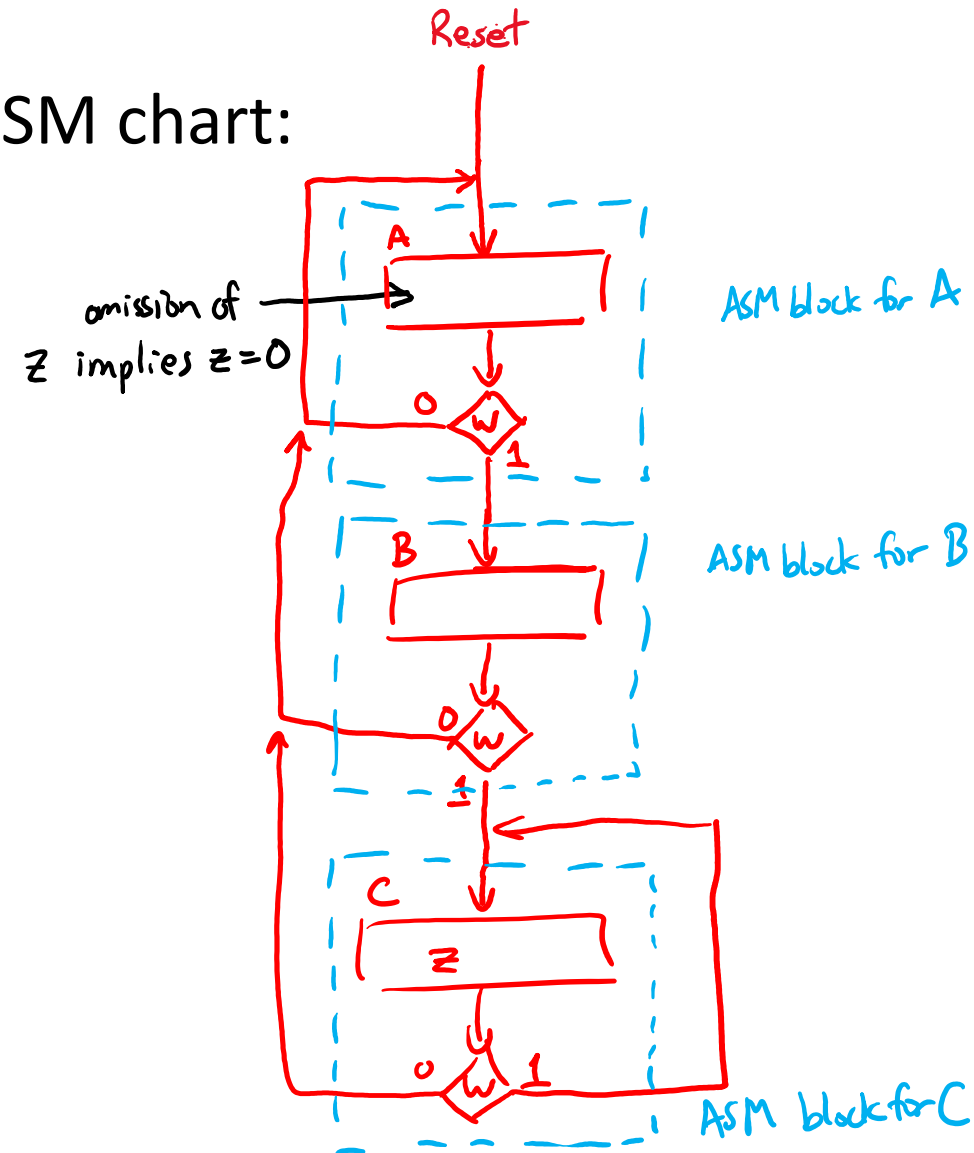

# Worked Example #2

❖ Convert this state machine to an ASM chart:

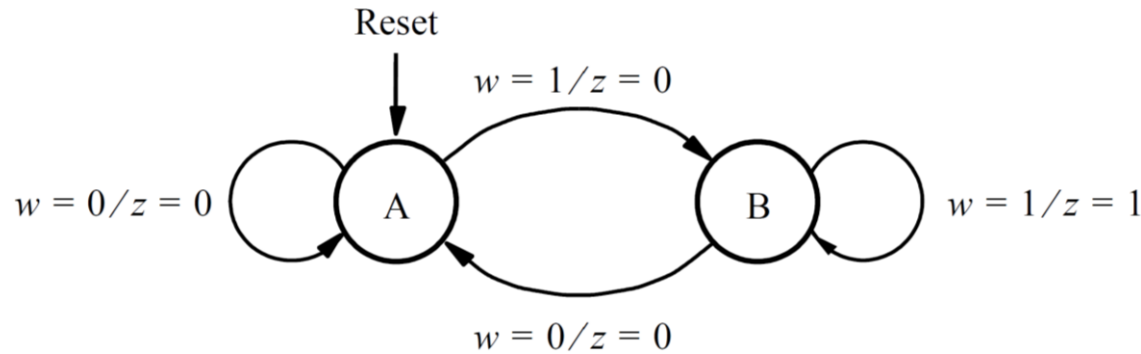

Mealy Machine  
 ↳ no output signals in state boxes

omission of conditional output box implies  $z=0$

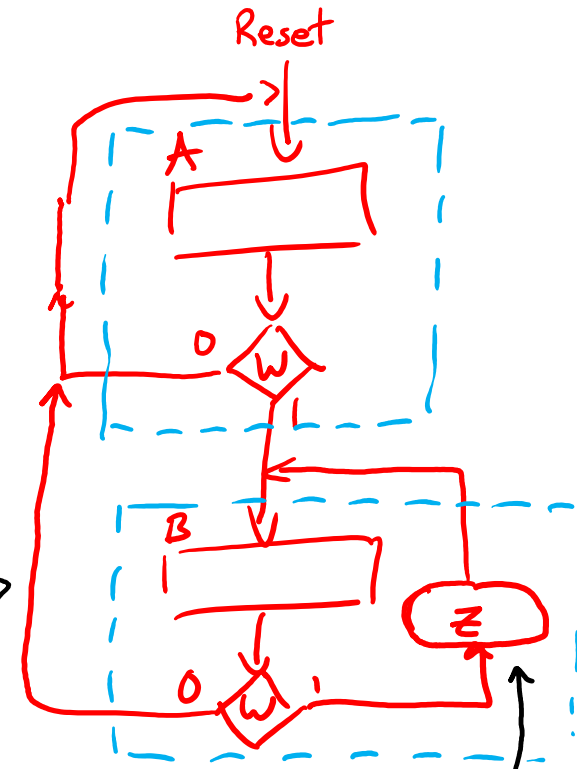

ASM block includes conditional output boxes

TECHNOLOGY

BREAK

# Example #3

- ❖ Draw an ASM chart for threeOnes – asserts out iff last 3 values of in were all 1's.

Moore machine  
Mealy machine

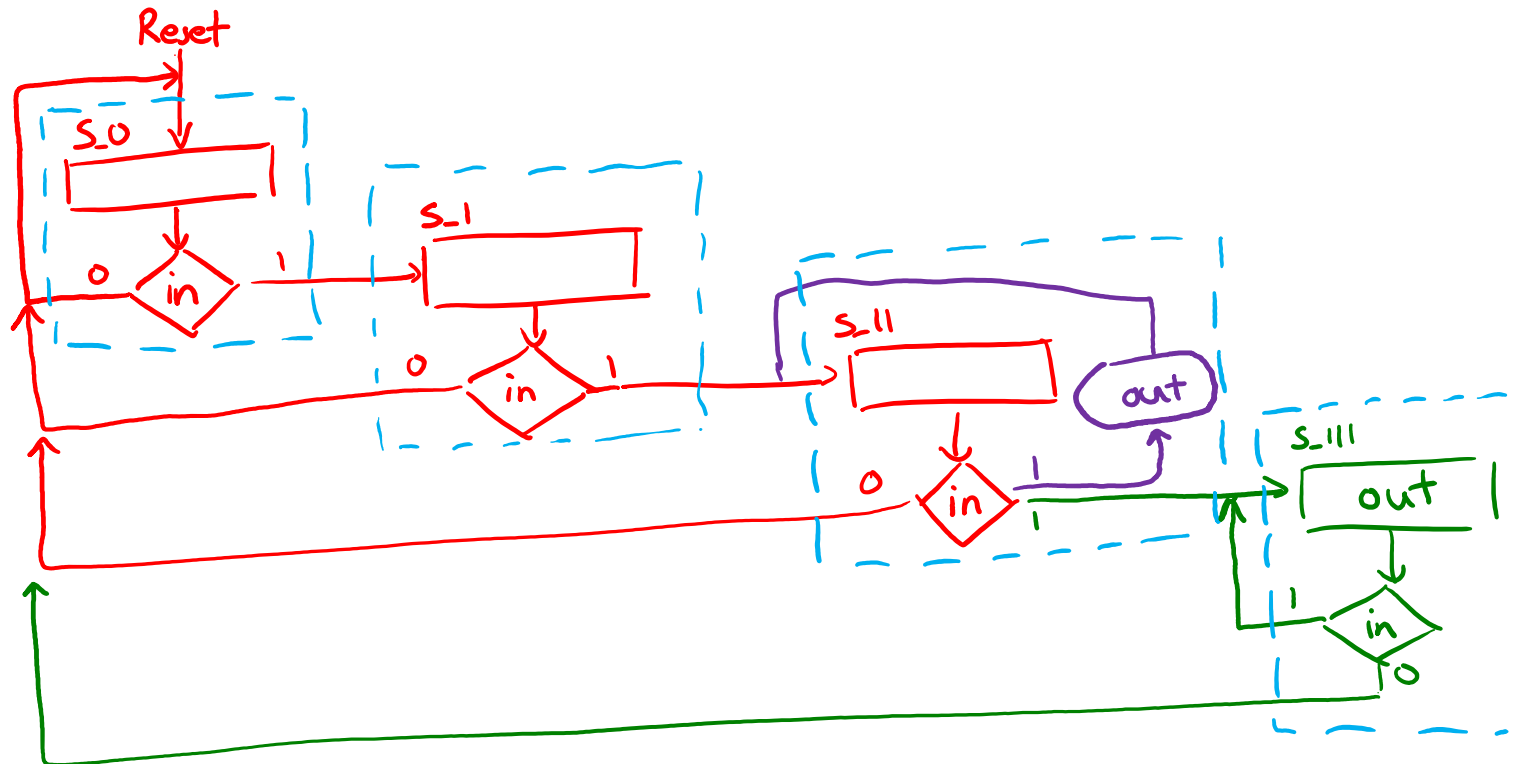

# Example #4

❖ Convert this state machine to an ASM chart:

- 1 input:  $X$ , 5 outputs:  $Y_a, Y_b, Y_c$  (Moore),  $Z_1, Z_2$  (Mealy)

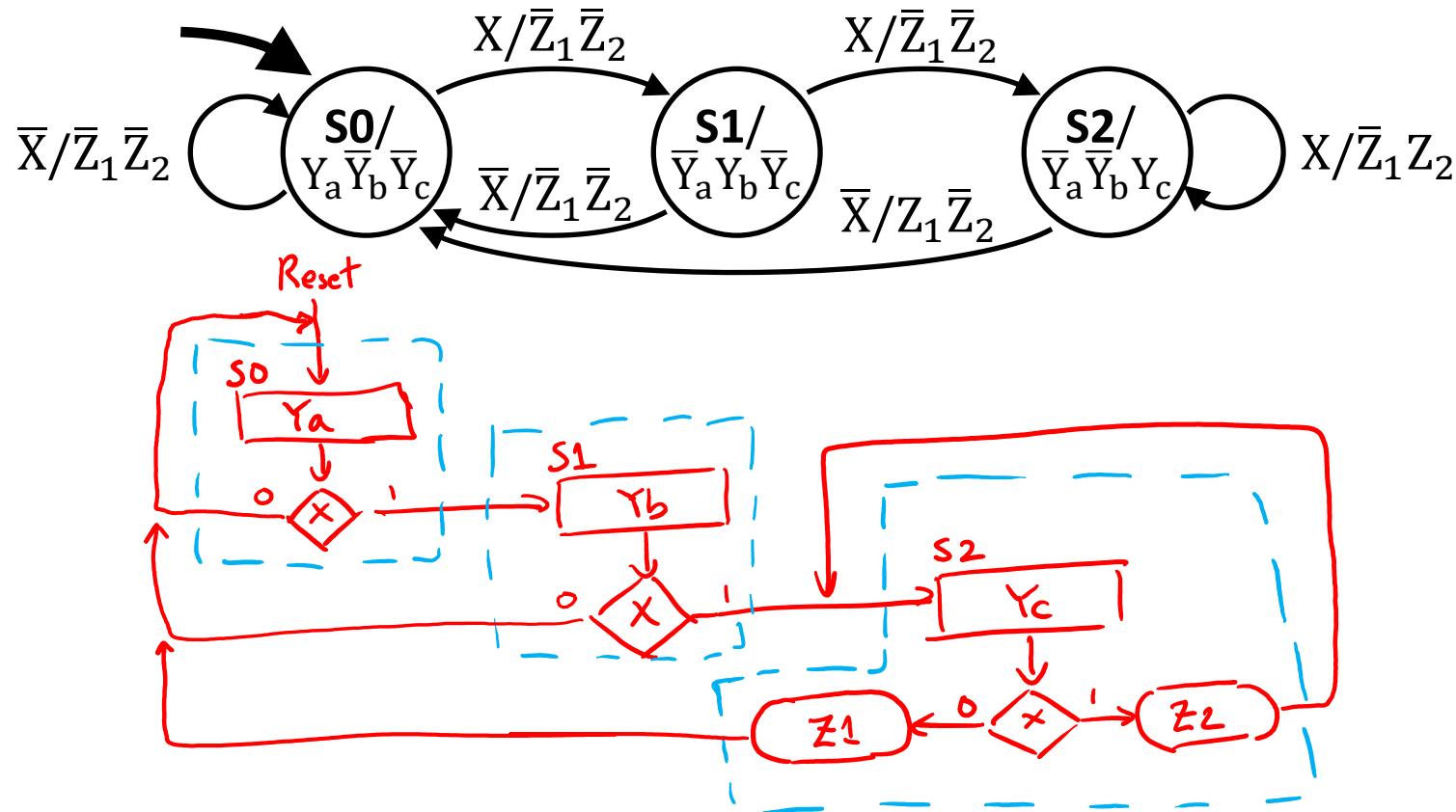

# Algorithms for Hardware

- ❖ *Sequential* algorithms:
  - Variables used as symbolic memory locations
  - Sequential execution dictates the ordering of operations
  
- ❖ Hardware implementation:
  - Registers store intermediate data (variables)
  - Datapath implements all necessary register operations (computations attached to register inputs)
  - A control path FSM specifies the ordering of register operations
  
- ❖ This design scheme sometimes referred to as **register-transfer level (RTL)** design

# Control and Datapath

- ❖ Signal classification in an SDS:
  - *Data*: Information manipulated/processed by the system
  - *Control*: Signals that coordinate and execute the system operations
- ❖ We can logically separate an SDS into two distinct parts/circuits:
  - **Datapath**: Parts needed for data manipulation (“the brawn”)
  - **Control**: Logic that tells the datapath what needs to be done (“the brain”)

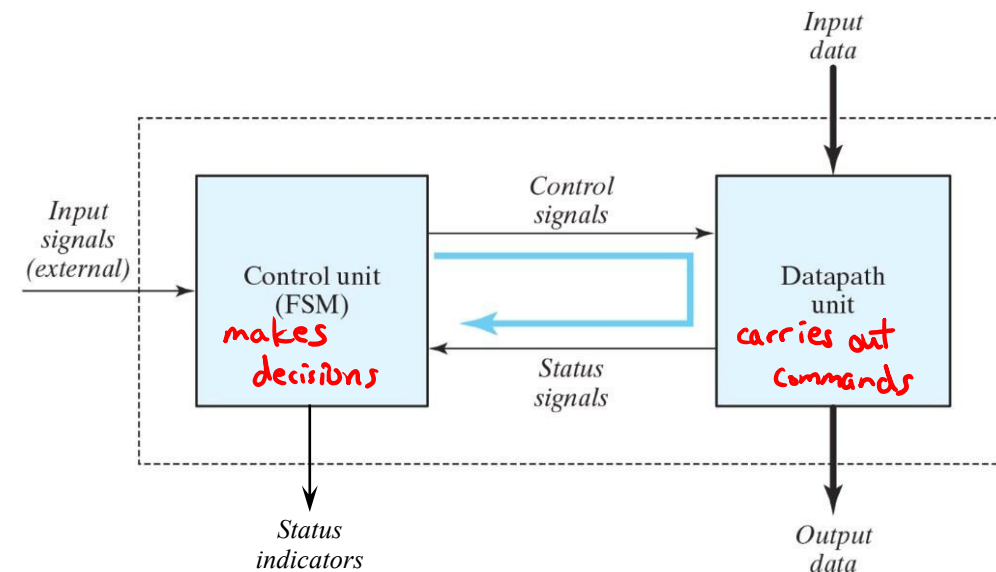

# Control and Datapath: FIFO Buffer

- ❖ Circular queue implementation from last lecture:
  - Datapath and control split?

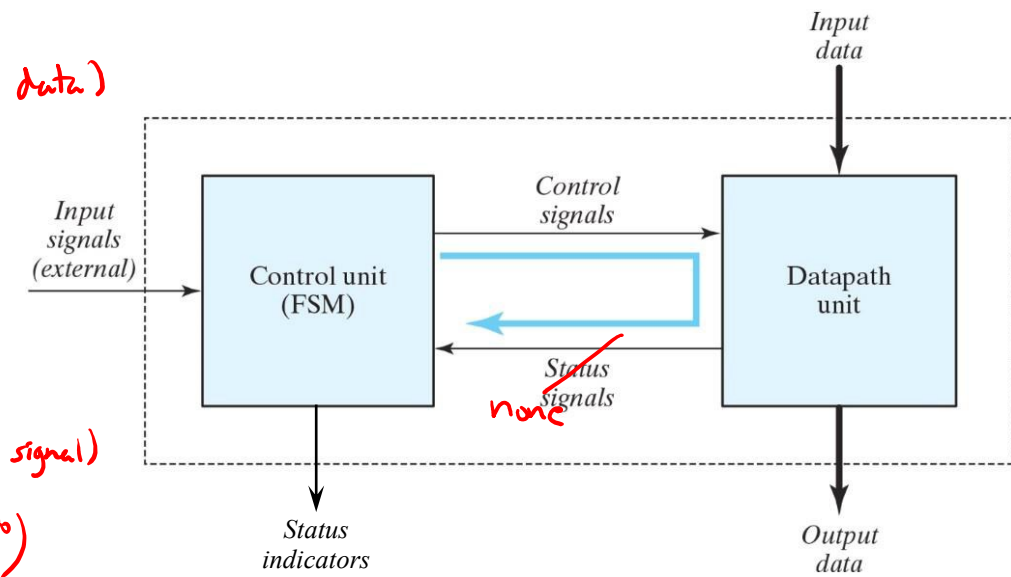
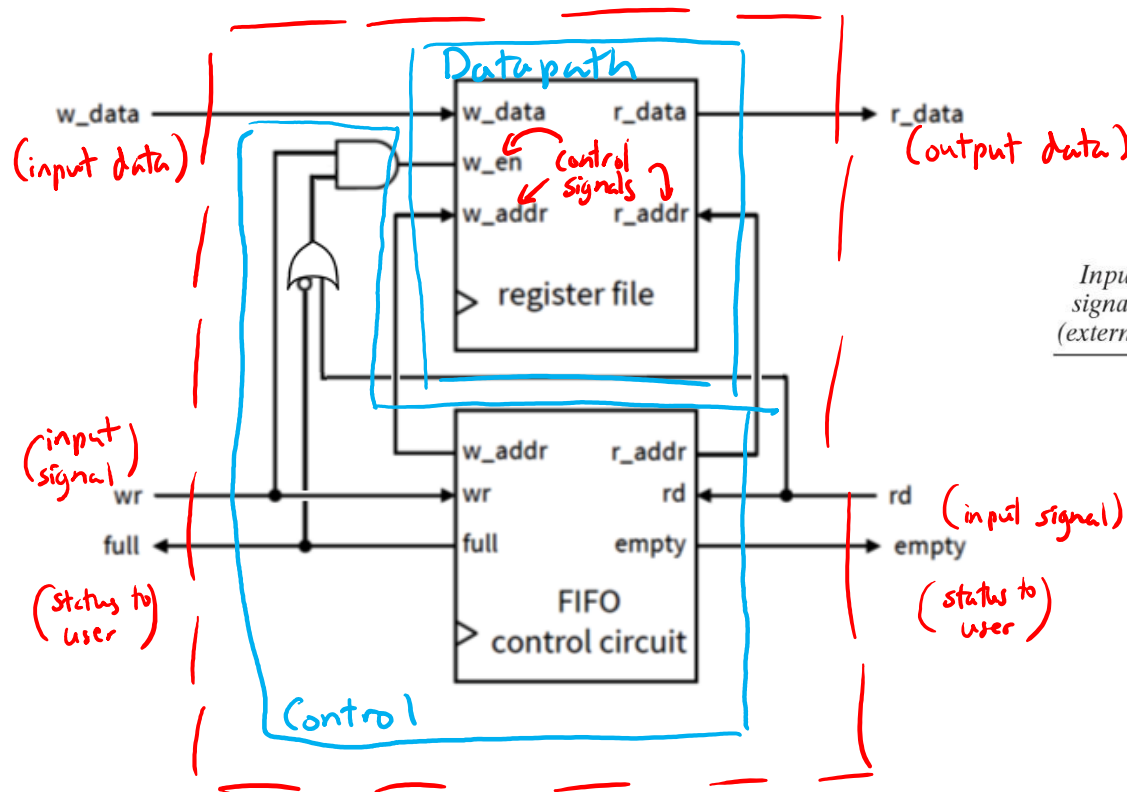

# Algorithms for Hardware: Schematic

*CL = combinational logic*  
*SL = sequential logic*

- ❖ The resulting system is called an algorithmic state machine (ASM) or FSM with a datapath (FSMD):

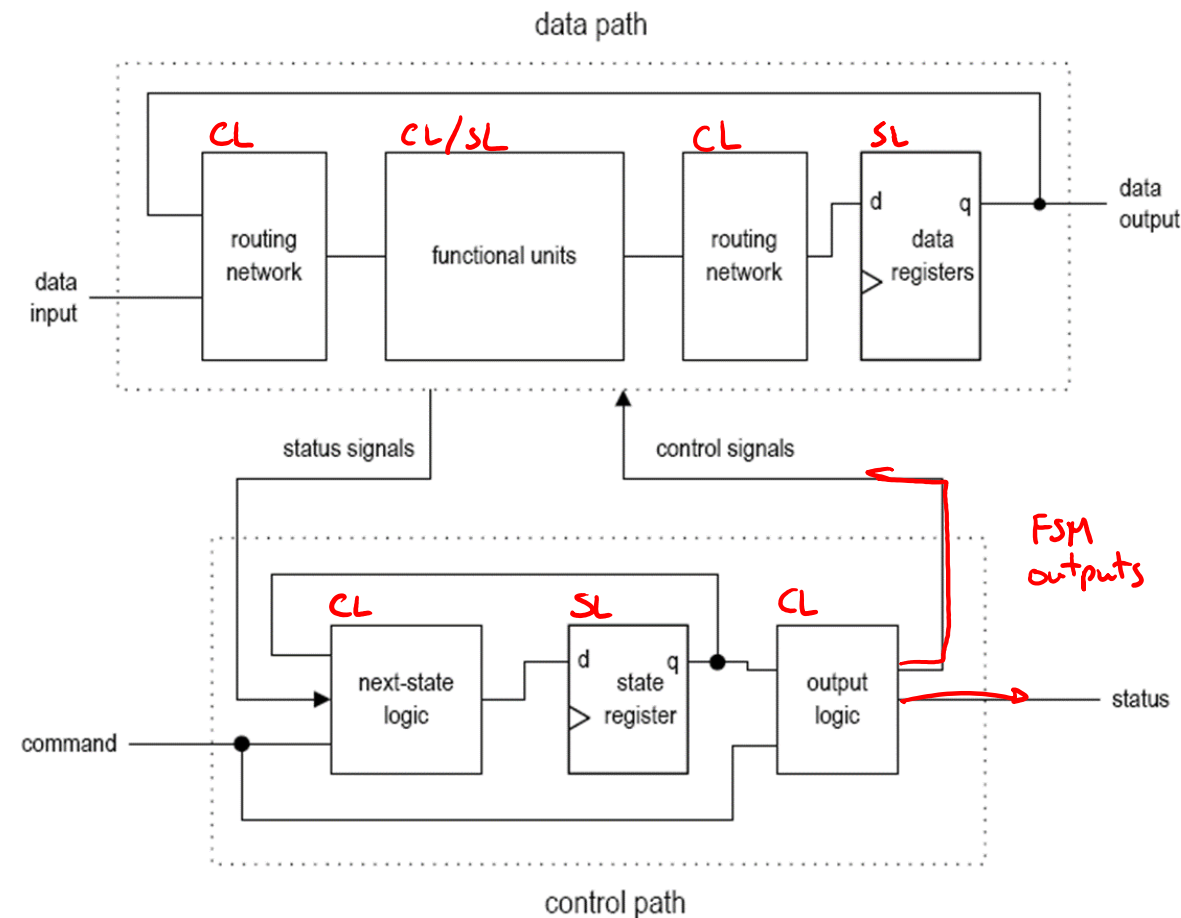

# RTL Operations

❖ Basic form:

$$r_{\text{dest}} \leftarrow f(r_{\text{src1}}, r_{\text{src2}}, \dots, r_{\text{srcn}})$$

*replacement operator*

- $r_i$  represent registers and  $f()$  represents some combinational function

❖ Examples:

- $r_1 \leftarrow 0$
- $r_2 \leftarrow r_1$
- $r_2 \leftarrow r_2 \gg 3$
- $i \leftarrow i + 1$
- $d \leftarrow s_1 + s_2 + s_3$
- $y \leftarrow a * a$

*"clear  $r_1$ "*

*"replace  $r_2$  with the value in  $r_1$ "*

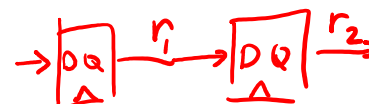
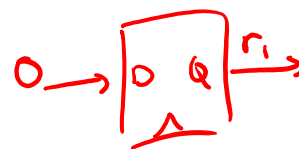

# RTL Operations: Timing

## ❖ Basic form:

$$r_{\text{dest}} \leftarrow f(r_{\text{src1}}, r_{\text{src2}}, \dots, r_{\text{srcn}})$$

- $r_i$  represent registers and  $f()$  represents some combinational function

## ❖ Timing Interpretation:

- After the start of a clock cycle, the outputs of all registers update
- During the rest of the clock cycle, these outputs propagate through the combinational circuit that performs  $f()$
- At the *next* clock trigger/cycle, the result is stored into  $r_{\text{dest}}$

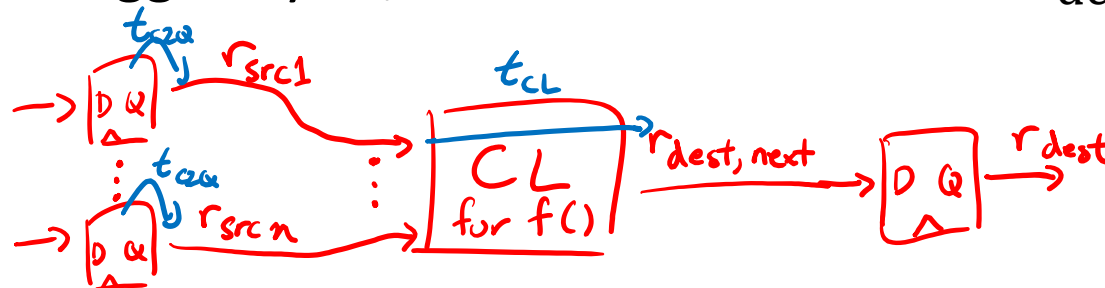

# RTL Operations: Example

❖ Basic form:

$$r_{\text{dest}} \leftarrow f(r_{\text{src1}}, r_{\text{src2}}, \dots, r_{\text{srcn}})$$

■  $r_i$  represent registers and  $f()$  represents some combinational function

❖ Implementation Example:  $a \leftarrow a - b + 1$

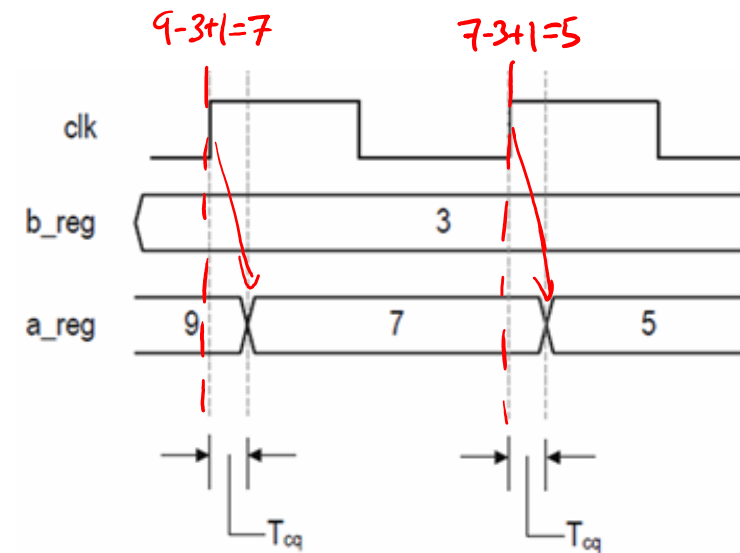
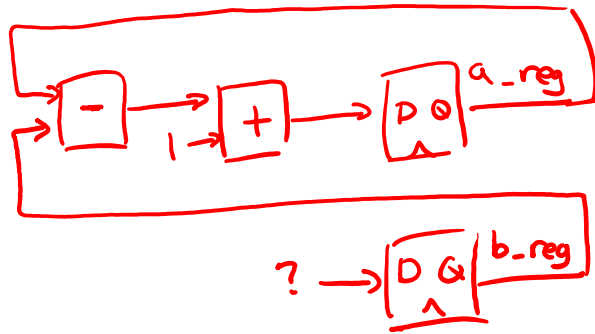

# Worked Example #5 (Preview)

- ❖ Convert the ASM chart for a control circuit shown in figure (b) to a state diagram:

