

DESIGN OF DIGITAL CIRCUITS AND SYSTEMS

Memory I

Instructor: Justin Hsia

Teaching Assistants:

Colton Carroll

Hemil Patel

Rasya Fawwaz

Grace Zhou

Quinlyn Donohue

Rose Maresh

Relevant Course Information

- ❖ HW1 can still be submitted tonight (1 late day)
 - Solution outline will be posted tomorrow (UW login)
- ❖ HW2 released today, due next Wednesday (4/15)
- ❖ Lab 1 reports due Friday (4/10), demos 4/12-17
- ❖ Lab 2 released today, due next Friday (4/17)
- ❖ Quiz 1 is Thursday, 4/9 in last 25 min of lecture
 - FSM design – state diagram, explain design decisions
 - Some past Quiz 1's available for practice on course website

Review Question

- ❖ Design an FSM with 1-bit input and 1-bit output that will output two consecutive 1's any time it sees the string "010" and outputs 0 otherwise
 - Example inputs: 0 0 1 0 0 1 1 0 1 0 1 0 1 1 ...
 outputs: 0 0 0 1 1 0 0 0 0 1 1 1 1 0 ...
 - How many state bits do we need?
 - Which state should be your initial/reset state?
- ❖ If you have time, design both a **Moore** machine and **Mealy** machine "from scratch" (*i.e.*, don't convert between the two)
 - Which seems easier to implement? Can you name specific ways that the SystemVerilog implementation will be "easier"?

Review Solution

- ❖ Design an FSM with 1-bit input and 1-bit output that will output two consecutive 1's any time it sees the string "010" and outputs 0 otherwise

Aside: Powers of 2 and Prefixes

- ❖ Here focusing on large numbers (*i.e.*, exponents > 0)
- ❖ SI prefixes are *ambiguous* if base 10 or 2
 - Note that $10^3 \approx 2^{10}$
- ❖ IEC prefixes are *unambiguously* base 2

SIZE PREFIXES (10^x for Disk, Communication; 2^x for Memory)

SI Size	Prefix	Symbol	IEC Size	Prefix	Symbol
10^3	Kilo-	K	2^{10}	Kibi-	Ki
10^6	Mega-	M	2^{20}	Mebi-	Mi
10^9	Giga-	G	2^{30}	Gibi-	Gi
10^{12}	Tera-	T	2^{40}	Tebi-	Ti
10^{15}	Peta-	P	2^{50}	Pebi-	Pi
10^{18}	Exa-	E	2^{60}	Exbi-	Ei
10^{21}	Zetta-	Z	2^{70}	Zebi-	Zi
10^{24}	Yotta-	Y	2^{80}	Yobi-	Yi

$2^0 = 1$
$2^1 = 2$
$2^2 = 4$
$2^3 = 8$
$2^4 = 16$
$2^5 = 32$
$2^6 = 64$
$2^7 = 128$
$2^8 = 256$
$2^9 = 512$
$2^{10} = 1024$

Large Powers of 2 and Units

- ❖ Because IEC prefixes are powers of 2^{10} , we can convert any large power of 2 as follows:
 - Note that we are only changing the *quantity* and the *units* remain the same

$$2^{XY} \text{ "things"} = \left[\begin{array}{l} Y=0 \rightarrow 1 \\ Y=1 \rightarrow 2 \\ Y=2 \rightarrow 4 \\ Y=3 \rightarrow 8 \\ Y=4 \rightarrow 16 \\ Y=5 \rightarrow 32 \\ Y=6 \rightarrow 64 \\ Y=7 \rightarrow 128 \\ Y=8 \rightarrow 256 \\ Y=9 \rightarrow 512 \end{array} \right] + \left[\begin{array}{l} X=0 \rightarrow \\ X=1 \rightarrow \text{Kibi-} \\ X=2 \rightarrow \text{Mebi-} \\ X=3 \rightarrow \text{Gibi-} \\ X=4 \rightarrow \text{Tebi-} \\ X=5 \rightarrow \text{Pebi-} \\ X=6 \rightarrow \text{Exbi-} \\ X=7 \rightarrow \text{Zebi-} \\ X=8 \rightarrow \text{Yobi-} \end{array} \right] + \text{"things"}$$

- ❖ Examples:
 - 2 GiB of memory?
 - 2^{47} things into IEC:

Memory

- ❖ Several forms of memory are available, which include:
 - ~~Secondary memory (e.g., hard disk, flash drive)~~
 - Read-only memory (ROM)
 - Random-access memory (RAM)
 - Register files
 - Small, fast, fixed-sized memory that hold CPU data state
 - First in, first out (FIFO) buffers

Embedded FPGA Memory

- ❖ An FPGA contains prefabricated memory modules
 - Intended for small or intermediate-sized storage
 - Contents of memory blocks can be configured via memory initialization files (*.mif*)

- ❖ The DE1-SoC's Cyclone V FPGA (Cyclone V SE A5) has:
 - 31k Adaptive Logic Modules (ALMs)
 - 4.45 Mbits of memory organized as 397 memory blocks, each with 10 kbits of storage (M10K)
 - Flexible, configurable memory storage available to the designer
 - Each M10K can act as single-port memory, dual-port RAM, shift register, ROM, or a FIFO buffer
 - More info on website: DE1-SoC → Cyclone V Handbook

DE1-SoC Memory

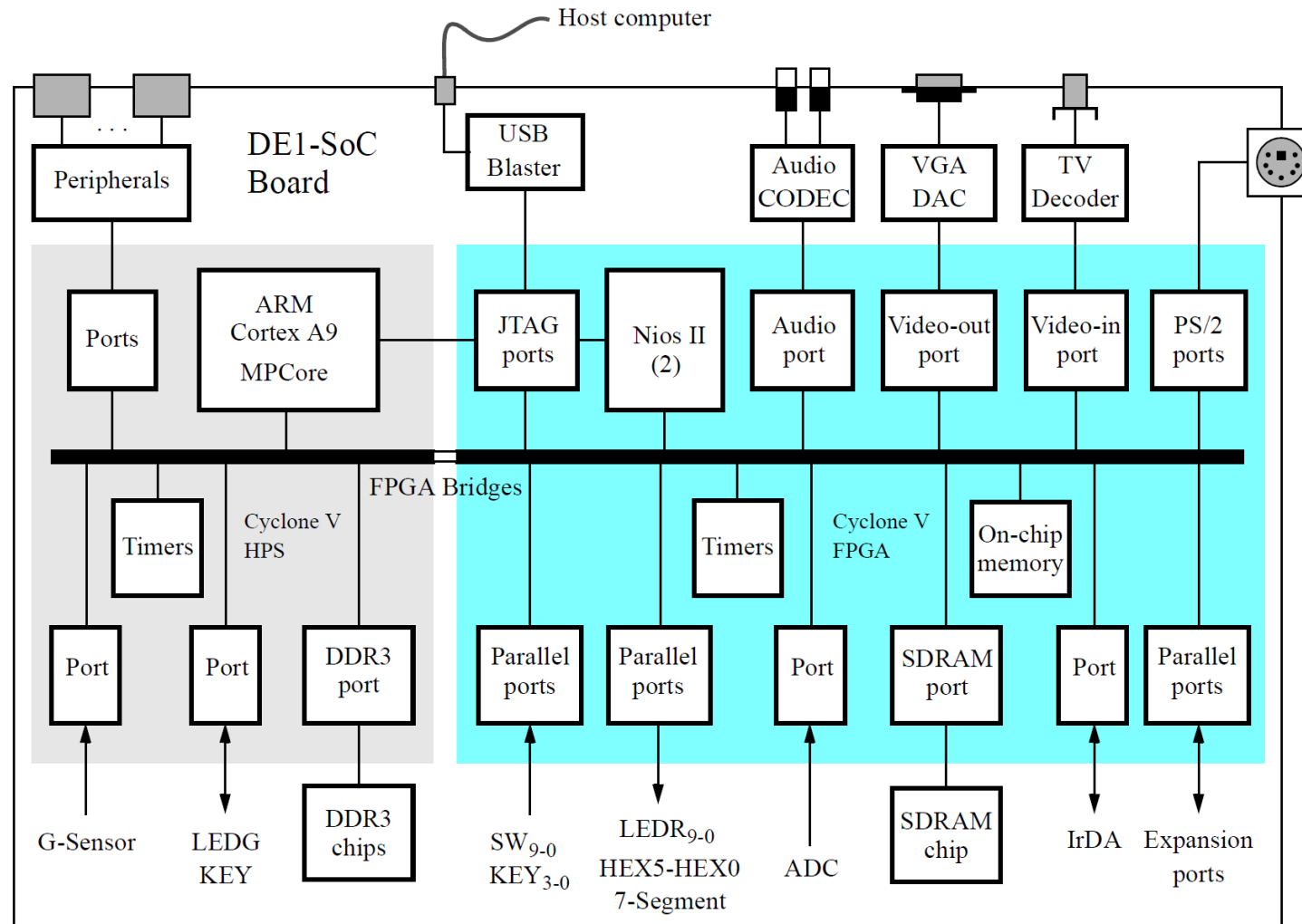
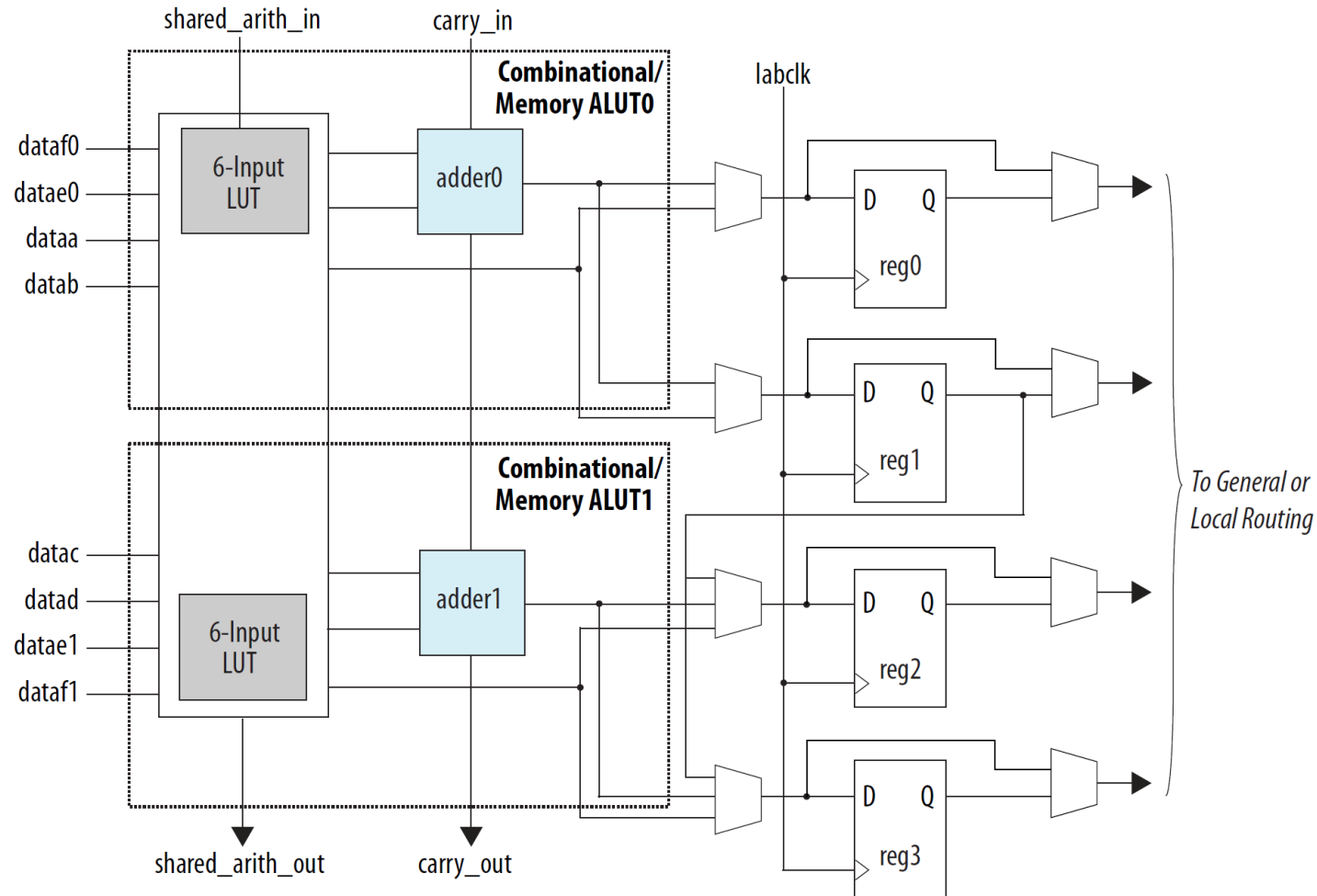

Figure 1. Block diagram of the DE1-SoC Computer.

Cyclone V Adaptive Logic Modules

Figure 1-5: ALM High-Level Block Diagram for Cyclone V Devices



Memory Modules

- ❖ Key characteristics of a simple memory module:
 - Width – the number of **bits** in a word
 - Depth – the number **words** in the module
 - Number of ports
 - Synchronicity of port access – whether or not accesses are controlled by a clock signal
 - Simultaneous address access – can the same address be used for both read and write operations

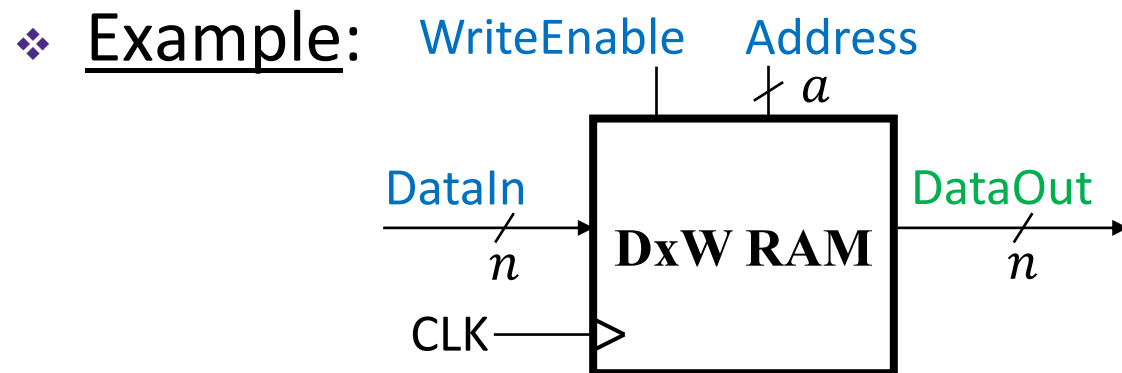

Memory Characteristics

- ❖ Memory units are specified as **depth** \times **width**.
- ❖ For the following memory units, answer:
 - 1) Memory capacity (in bits and bytes using IEC prefixes)
 - 2) Width of address bus (a)
 - 3) Width of data output bus (n)
- ❖ Memory 1: $8\text{Ki} \times 32$
- ❖ Memory 2: $2\text{Gi} \times 8$

TECHNOLOGY

BREAK

Memory Type #1: ROM

❖ Read-Only Memory

- A purely *combinational* circuit (no internal state)
- Output is determined solely by address input

❖ In an FPGA:

- No actual embedded ROM, but can be emulated by a combinational circuit or a RAM with the write operation disabled
- Only practical for small tables

❖ In SystemVerilog:

- Define the ROM content as a 2-dimensional constant
- Oftentimes a selected assignment or case statement

Example ROM

❖ Hex-to-7seg LED decoder:

- Segments:
 - Active low

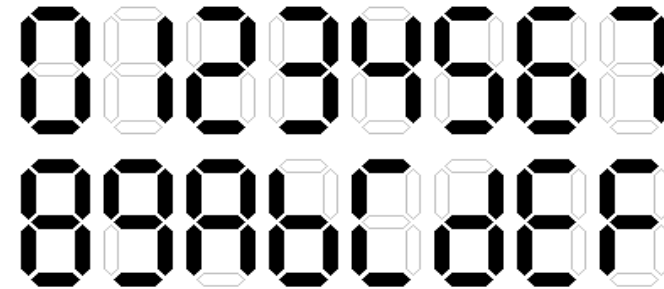
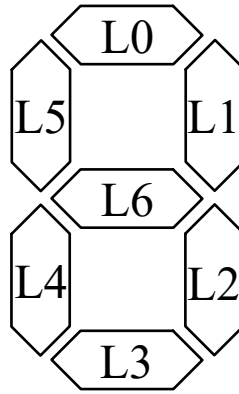

❖ ROM size?

B3	B2	B1	B0	L0	L1	L2	L3	L4	L5	L6
0	0	0	0	0	0	0	0	0	0	1
0	0	0	1	1	0	0	1	1	1	1
0	0	1	0	0	0	1	0	0	1	0
		⋮					⋮			
1	1	0	1	1	0	0	0	0	1	0
1	1	1	0	0	1	1	0	0	0	0
1	1	1	1	0	1	1	1	0	0	0

Example ROM: Case Implementation

```
module ROM_case(addr, data);  
  
    input  logic [3:0] addr;  
    output logic [6:0] data;  
  
    always_comb  
        case (addr)  
            //                L6543210  
            4'h0: data = 7'b1000000;  
            4'h1: data = 7'b1111001;  
            4'h2: data = 7'b0100100;  
            // ...  
            4'hD: data = 7'b0100001;  
            4'hE: data = 7'b0000110;  
            4'hF: data = 7'b0001110;  
        endcase  
  
endmodule // ROM_case
```

Reading Data from a File

- ❖ Hard-coded values in your SV files can be tedious to format, debug, and swap out!
- ❖ Verilog provides *system tasks* to read data from a text file into an array: `$readmemb()` and `$readmemh()`
 - Basic usage: `$readmemb("file.txt", my_array);`
 - Reads in numerals (in **binary** or **hex**) from file separated by *whitespace* (*i.e.*, spaces, tabs, newlines)
 - Can avoid some recompilation
 - File can have any extension
 - Be very careful with dimensions of array and ordering of data in file!

Example ROM: File Implementation

```
module ROM_file(addr, data);  
    input logic [3:0] addr;  
    output logic [6:0] data;  
  
    logic [6:0] ROM [0:15]; // (!) unpacked dimension  
  
    initial  
        // reads binary values from file into array  
        $readmemb("seg7decode.txt", ROM);  
  
    assign data = ROM[addr];  
endmodule // ROM_file
```

seg7decode.txt:

1000000	1111001	0100100	0110000
0011001	0010010	0000010	1111000
0000000	0010000	0001000	0000011
1000110	0100001	0000110	0001110

Dynamic Array Indexing Operation

- ❖ A signal can be used as an index to access an element in the array:

```
assign data = ROM[addr];
```

equivalent to

```
always_comb
case (addr)
  4'h0: data = ROM[0];
  4'h1: data = ROM[1];
  // ...
  4'hE: data = ROM[14];
  4'hF: data = ROM[15];
endcase
```

Synchronicity Revisited

- ❖ To synchronize either the address input or ROM output, we can add a register as appropriate
 - Sometimes called “registering” the input or output to make your module “synchronous”
 - In SystemVerilog, can be done inside or outside of the module:

```
initial
    $readmemb("seg7decode.txt", ROM);

// internally-registered ROM module
always_ff @(posedge clk)
    data <= ROM[addr];
```

Memory Type #2: RAM

- ❖ **Random-Access Memory**
 - Can read and write to any address instead of having to read in sequence (*e.g.*, a magnetic disk)
- ❖ Can be implemented using different semiconductor technologies:
 - Static RAM (SRAM): Uses flip-flops to store data
 - Dynamic RAM (DRAM): Uses capacitors and transistors to store data that need to be periodically refreshed
 - SRAM is faster but more expensive than DRAM
- ❖ In a typical home computer:
 - CPU registers and caches are SRAM
 - “Memory” is *synchronous* DRAM (SDRAM)

Example RAM Hardware

- ❖ Internal structure of an 8×4 static RAM:
 - Figure 15.18 from Wakerly

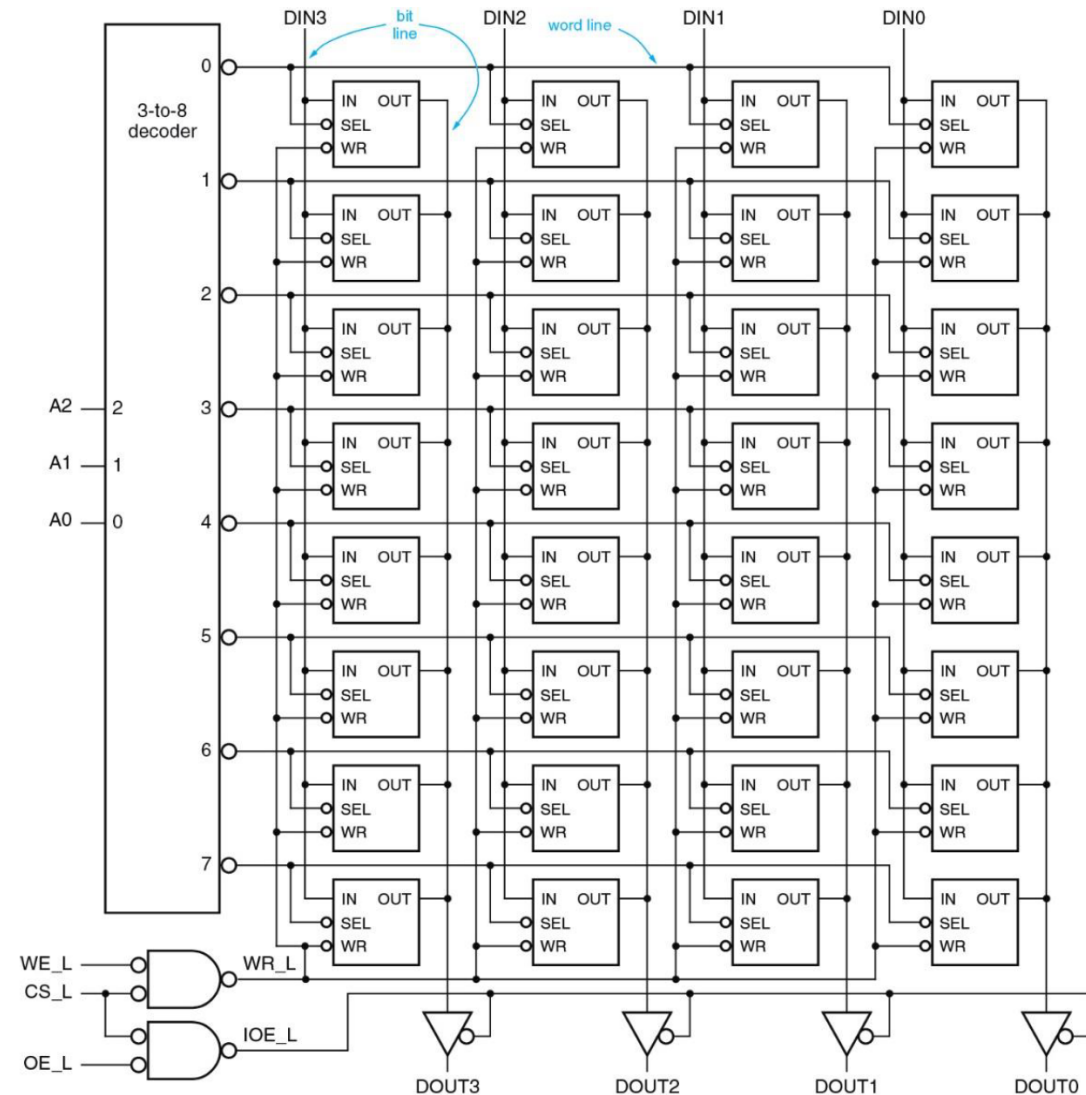

RAM Variants

❖ Note that not all of the terminology used here is standardized:

1) Synchronicity

- Are the operations controlled by the clock?
- Can be applied to reading and writing independently

2) Number of ports

- Not in the same sense as number of SV module ports
- Can roughly think of as “channels” (set of addr in, data in, write enable, and data out ports) – how many reads and writes can occur simultaneously?

3) Address independence

- Are the port's read and write operation based on the same or independent addr in buses?

Synchronous Single-Port RAM

❖ Synchronous Inputs:

- wren (1 = write, 0 = read)
- addr (A -bit address)
- din (D -bit data)

❖ Synchronous Output:

- dout (D -bit data)

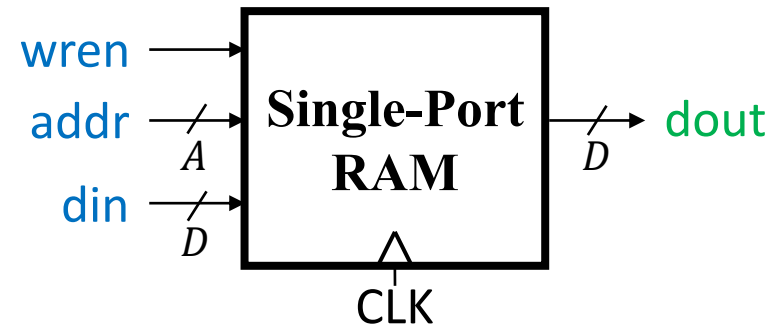

❖ Implementation hints:

- Will need an internal RAM array of what size?
- To synchronize, should update on clock triggers
- What should dout do when wren = 1?

Synchronous Single-Port RAM: Implementation (1/2)

```
module RAM_single #(parameter A, D)
    (clk, wren, addr, din, dout);
```

```
endmodule // RAM_single
```