

Welcome to CSE370: Introduction to Digital Design

- Course staff
 - Gaetano Borriello, Sorin Lerner, Valdis Riekstins
- Course web
 - www.cs.washington.edu/education/courses/370/00sp/
- This week
 - What is logic design?
 - What is digital hardware?
 - What will we be doing in this class?

 - Class administration, overview of course web, and logistics

CSE 370 - Spring 2000 - Introduction - 1

Why are we here?

- Obvious reasons
 - this course is part of the CS/CompE requirements
 - it is the implementation basis for all modern computing devices
 - building large things from small components
 - provide another model of what a computer is
- More important reasons
 - the inherent parallelism in hardware is often our first exposure to parallel computation
 - it offers an interesting counterpoint to software design and is therefore useful in furthering our understanding of computation, in general

CSE 370 - Spring 2000 - Introduction - 2

What will we learn in CSE370?

- The language of logic design
 - ┆ Boolean algebra, logic minimization, state, timing, CAD tools
- The concept of state in digital systems
 - ┆ analogous to variables and program counters in software systems
- How to specify/simulate/compile our designs
 - ┆ hardware description languages
 - ┆ tools to simulate the workings of our designs
 - ┆ logic compilers to synthesize the hardware blocks of our designs
 - ┆ mapping onto programmable hardware (code generation)
- Contrast with software design
 - ┆ both map well-posed problems to physical devices
 - ┆ both must be flawless...this is the price we pay for using discrete math

Applications of logic design

- Conventional computer design
 - ┆ CPUs, busses, peripherals
- Networking and communications
 - ┆ phones, modems, routers
- Embedded products
 - ┆ in cars, toys, appliances, entertainment devices
- Scientific equipment
 - ┆ testing, sensing, reporting
- The world of computing is much much bigger than just PCs!

A quick history lesson

- 1850: George Boole invents Boolean algebra
 - maps logical propositions to symbols
 - permits manipulation of logic statements using mathematics
- 1938: Claude Shannon links Boolean algebra to switches
 - his Masters' thesis
- 1945: John von Neumann develops the first stored program computer
 - its switching elements are vacuum tubes (a big advance from relays)
- 1946: ENIAC . . . The world's first completely electronic computer
 - 18,000 vacuum tubes
 - several hundred multiplications per minute
- 1947: Shockley, Brittain, and Bardeen invent the transistor
 - replaces vacuum tubes
 - enable integration of multiple devices into one package
 - gateway to modern electronics

CSE 370 - Spring 2000 - Introduction - 5

What is logic design?

- What is design?
 - given a specification of a problem, come up with a way of solving it choosing appropriately from a collection of available components
 - while meeting some criteria for size, cost, power, beauty, elegance, etc.
- What is logic design?
 - determining the collection of digital logic components to perform a specified control and/or data manipulation and/or communication function and the interconnections between them
 - which logic components to choose? – there are many implementation technologies (e.g., off-the-shelf fixed-function components, programmable devices, transistors on a chip, etc.)
 - the design may need to be optimized and/or transformed to meet design constraints

CSE 370 - Spring 2000 - Introduction - 6

What is digital hardware?

- Collection of devices that sense and/or control wires that carry a digital value (i.e., a physical quantity that can be interpreted as a "0" or "1")
 - ┆ example: digital logic where voltage < 0.8v is a "0" and > 2.0v is a "1"
 - ┆ example: pair of transmission wires where a "0" or "1" is distinguished by which wire has a higher voltage (differential)
 - ┆ example: orientation of magnetization signifies a "0" or a "1"
- Primitive digital hardware devices
 - ┆ logic computation devices (sense and drive)
 - ┆ are two wires both "1" - make another be "1" (AND)
 - ┆ is at least one of two wires "1" - make another be "1" (OR)
 - ┆ is a wire "1" - then make another be "0" (NOT)
 - ┆ memory devices (store)
 - ┆ store a value
 - ┆ recall a value previously stored

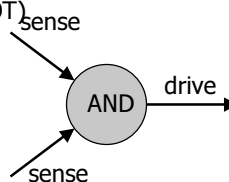

CSE 370 - Spring 2000 - Introduction - 7

Source: Microsoft Encarta

What is happening now in digital design?

- Big change in the way industry does hardware design over last few years
 - ┆ larger and larger designs
 - ┆ shorter and shorter time to market
 - ┆ cheaper and cheaper products
- Scale
 - ┆ pervasive use of computer-aided design tools over hand methods
 - ┆ multiple levels of design representation
- Time
 - ┆ emphasis on abstract design representations
 - ┆ programmable rather than fixed function components
 - ┆ automatic synthesis techniques
 - ┆ importance of sound design methodologies
- Cost
 - ┆ higher levels of integration
 - ┆ use of simulation to debug designs

CSE 370 - Spring 2000 - Introduction - 8

CSE 370: concepts/skills/abilities

- Understanding the basics of logic design (concepts)
- Understanding sound design methodologies (concepts)
- Modern specification methods (concepts)
- Familiarity with a full set of CAD tools (skills)
- Appreciation for the differences and similarities (abilities) in hardware and software design

New ability: to accomplish the logic design task with the aid of computer-aided design tools and map a problem description into an implementation with programmable logic devices after validation via simulation and understanding of the advantages/disadvantages as compared to a software implementation

Computation: abstract vs. implementation

- Up to now, computation has been a mental exercise (paper, programs)
- This class is about physically implementing computation using physical devices that use voltages to represent logical values
- Basic units of computation are:
 - representation: "0", "1" on a wire
set of wires (e.g., for binary integers)
 - assignment: $x = y$
 - data operations: $x + y - 5$
 - control:
 - sequential statements: A; B; C
 - conditionals: if $x == 1$ then y
 - loops: for ($i = 1$; $i == 10$, $i++$)
 - procedures: A; proc(...); B;
- We will study how each of these are implemented in hardware and composed into computational structures

Switches: basic element of physical implementations

- Implementing a simple circuit (arrow shows action if wire changes to "1"):

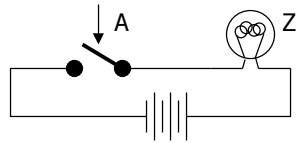

close switch (if A is "1" or asserted)
and turn on light bulb (Z)

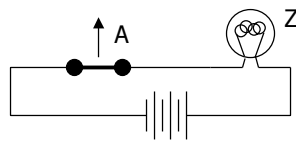

open switch (if A is "0" or unasserted)
and turn off light bulb (Z)

$$Z \equiv A$$

Switches (cont'd)

- Compose switches into more complex ones (Boolean functions):

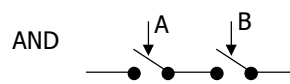

$$Z \equiv A \text{ and } B$$

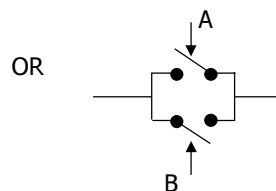

$$Z \equiv A \text{ or } B$$

Switching networks

- Switch settings
 - determine whether or not a conducting path exists to light the light bulb
- To build larger computations
 - use a light bulb (output of the network) to set other switches (inputs to another network).
- Connect together switching networks
 - to construct larger switching networks, i.e., there is a way to connect outputs of one network to the inputs of the next.

CSE 370 - Spring 2000 - Introduction - 13

Relay networks

- A simple way to convert between conducting paths and switch settings is to use (electro-mechanical) relays.
- What is a relay?

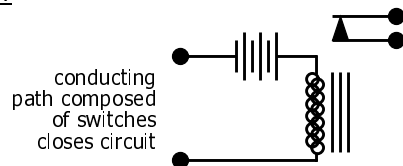

current flowing through coil magnetizes core and causes normally closed (nc) contact to be pulled open

when no current flows, the spring of the contact returns it to its normal position

- What determines the switching speed of a relay network?

CSE 370 - Spring 2000 - Introduction - 14

Transistor networks

- Relays aren't used much anymore
 - ▮ some traffic light controllers are still electro-mechanical
- Modern digital systems are designed in CMOS technology
 - ▮ MOS stands for Metal-Oxide on Semiconductor
 - ▮ C is for complementary because there are both normally-open and normally-closed switches
- MOS transistors act as voltage-controlled switches
 - ▮ similar, though easier to work with than relays.

CSE 370 - Spring 2000 - Introduction - 15

MOS transistors

- MOS transistors have three terminals: drain, gate, and source
 - ▮ they act as switches in the following way:
 - if the voltage on the gate terminal is (some amount) higher/lower than the source terminal then a conducting path will be established between the drain and source terminals

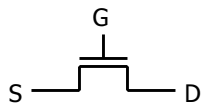

n-channel
open when voltage at G is low
closes when:
 $\text{voltage}(G) > \text{voltage}(S) + \epsilon$

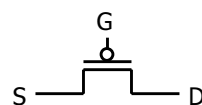

p-channel
closed when voltage at G is low
opens when:
 $\text{voltage}(G) < \text{voltage}(S) - \epsilon$

CSE 370 - Spring 2000 - Introduction - 16

MOS networks

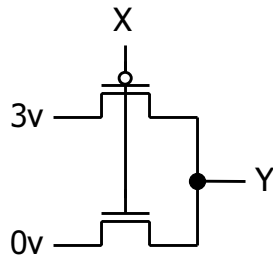

what is the relationship between x and y?

x	y
0 volts	
3 volts	

CSE 370 - Spring 2000 - Introduction - 17

Two input networks

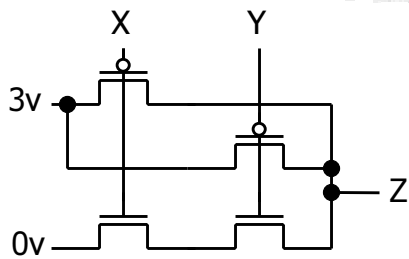

what is the relationship between x, y and z?

x	y	z
0 volts	0 volts	
0 volts	3 volts	
3 volts	0 volts	
3 volts	3 volts	

CSE 370 - Spring 2000 - Introduction - 18

Speed of MOS networks

- What influences the speed of CMOS networks?
 - charging and discharging of voltages on wires and gates of transistors

Representation of digital designs

- Physical devices (transistors, relays)
 - Switches
 - Truth tables
 - Boolean algebra
 - Gates
 - Waveforms
 - Finite state behavior
 - Register-transfer behavior
 - Concurrent abstract specifications
- scope of CSE 370
-

Digital vs. analog

- It is convenient to think of digital systems as having only discrete, digital, input/output values
- In reality, real electronic components exhibit continuous, analog, behavior
- Why do we make this abstraction?
 -
 -
- Why does it work?
 -

Mapping from physical world to binary world

Technology	State 0	State 1
Relay logic	Circuit Open	Circuit Closed
CMOS logic	0.0-1.0 volts	2.0-3.0 volts
Transistor transistor logic (TTL)	0.0-0.8 volts	2.0-5.0 volts
Fiber Optics	Light off	Light on
Dynamic RAM	Discharged capacitor	Charged capacitor
Nonvolatile memory (erasable)	Trapped electrons	No trapped electrons
Programmable ROM	Fuse blown	Fuse intact
Bubble memory	No magnetic bubble	Bubble present
Magnetic disk	No flux reversal	Flux reversal
Compact disc	No pit	Pit

Combinational vs. sequential digital circuits

- A simple model of a digital system is a unit with inputs and outputs:

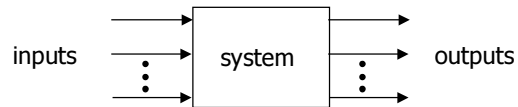

- Combinational means "memory-less"
 - a digital circuit is combinational if its output values only depend on its input values

Combinational logic symbols

- Common combinational logic systems have standard symbols called logic gates

- Buffer, NOT



- AND, NAND

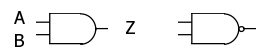

- OR, NOR

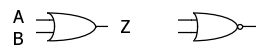

easy to implement
with CMOS transistors
(the switches we have
available and use most)

Sequential logic

- Sequential systems
 - ┆ exhibit behaviors (output values) that depend not only on the current input values, but also on previous input values
- In reality, all real circuits are sequential
 - ┆ because the outputs do not change instantaneously after an input change
 - ┆ why not, and why is it then sequential?
- A fundamental abstraction of digital design is to reason (mostly) about steady-state behaviors
 - ┆ look at the outputs only after sufficient time has elapsed for the system to make its required changes and settle down

Synchronous sequential digital systems

- Outputs of a combinational circuit depend only on current inputs
 - ┆ after sufficient time has elapsed
- Sequential circuits have memory
 - ┆ even after waiting for the transient activity to finish
- The steady-state abstraction is so useful that most designers use a form of it when constructing sequential circuits:
 - ┆ the memory of a system is represented as its state
 - ┆ changes in system state are only allowed to occur at specific times controlled by an external periodic clock
 - ┆ the clock period is the time that elapses between state changes it must be sufficiently long so that the system reaches a steady-state before the next state change at the end of the period

Example of combinational and sequential logic

■ Combinational:

- input A, B
- wait for clock edge
- observe C
- wait for another clock edge
- observe C again: will stay the same

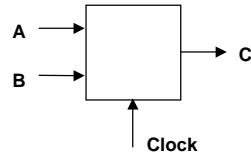

■ Sequential:

- input A, B
- wait for clock edge
- observe C
- wait for another clock edge
- observe C again: may be different

Abstractions

■ Some we've seen already

- digital interpretation of analog values
- transistors as switches
- switches as logic gates
- use of a clock to realize a synchronous sequential circuit

■ Some others we will see

- truth tables and Boolean algebra to represent combinational logic
- encoding of signals with more than two logical values into binary form
- state diagrams to represent sequential logic
- hardware description languages to represent digital logic
- waveforms to represent temporal behavior

An example

- Calendar subsystem: number of days in a month (to control watch display)
 - used in controlling the display of a wrist-watch LCD screen
 - inputs: month, leap year flag
 - outputs: number of days

Implementation in software

```
integer number_of_days ( month, leap_year_flag) {
  switch (month) {
    case 1: return (31);
    case 2: if (leap_year_flag == 1) then return (29)
           else return (28);
    case 3: return (31);
    ...
    case 12: return (31);
    default: return (0);
  }
}
```

Implementation as a combinational digital system

Encoding:

- ┆ how many bits for each input/output?
- ┆ binary number for month
- ┆ four wires for 28, 29, 30, and 31

Behavior:

- ┆ combinational
- ┆ truth table specification

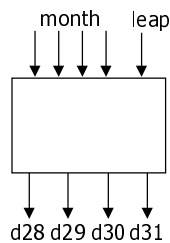

month	leap	d28	d29	d30	d31
0000	-	-	-	-	-
0001	-	0	0	0	1
0010	0	1	0	0	0
0010	1	0	1	0	0
0011	-	0	0	0	1
0100	-	0	0	1	0
0101	-	0	0	0	1
0110	-	0	0	1	0
0111	-	0	0	0	1
1000	-	0	0	0	1
1001	-	0	0	1	0
1010	-	0	0	0	1
1011	-	0	0	1	0
1100	-	0	0	0	1
1101	-	-	-	-	-
111-	-	-	-	-	-

Combinational example (cont'd)

Truth-table to logic to switches to gates

- ┆ $d_{28} = 1$ when month=0010 and leap=0
- ┆ $d_{28} = m_8 \cdot m_4 \cdot m_2 \cdot m_1 \cdot \text{leap}'$

- ┆ $d_{31} = 1$ when month=0001 or month=0011 or ... month=1100
- ┆ $d_{31} = (m_8 \cdot m_4 \cdot m_2 \cdot m_1) + (m_8 \cdot m_4 \cdot m_2 \cdot m_1) + \dots (m_8 \cdot m_4 \cdot m_2 \cdot m_1)$
- ┆ $d_{31} =$ can we simplify more?

month	leap	d28	d29	d30	d31
0001	-	0	0	0	1
0010	0	1	0	0	0
0010	1	0	1	0	0
0011	-	0	0	0	1
0100	-	0	0	1	0
...					
1100	-	0	0	0	1
1101	-	-	-	-	-
111-	-	-	-	-	-
0000	-	-	-	-	-

Combinational example (cont'd)

- $d_{28} = m_8' \cdot m_4' \cdot m_2 \cdot m_1' \cdot \text{leap}'$
- $d_{29} = m_8' \cdot m_4' \cdot m_2 \cdot m_1' \cdot \text{leap}$
- $d_{30} = (m_8' \cdot m_4 \cdot m_2' \cdot m_1') + (m_8' \cdot m_4 \cdot m_2 \cdot m_1') + (m_8 \cdot m_4' \cdot m_2' \cdot m_1) + (m_8 \cdot m_4' \cdot m_2 \cdot m_1)$
- $d_{31} = (m_8' \cdot m_4' \cdot m_2' \cdot m_1) + (m_8' \cdot m_4' \cdot m_2 \cdot m_1) + (m_8' \cdot m_4 \cdot m_2' \cdot m_1) + (m_8' \cdot m_4 \cdot m_2 \cdot m_1) + (m_8 \cdot m_4' \cdot m_2' \cdot m_4') + (m_8 \cdot m_4' \cdot m_2 \cdot m_1') + (m_8 \cdot m_4 \cdot m_2' \cdot m_1')$

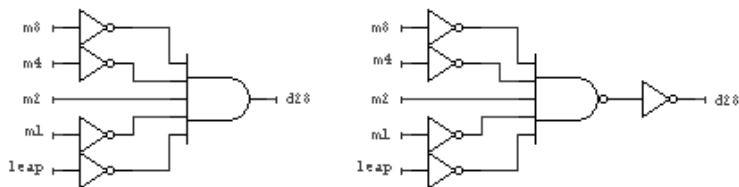

CSE 370 - Spring 2000 - Introduction - 33

Combinational example (cont'd)

- $d_{28} = m_8' \cdot m_4' \cdot m_2 \cdot m_1' \cdot \text{leap}'$
- $d_{29} = m_8' \cdot m_4' \cdot m_2 \cdot m_1' \cdot \text{leap}$
- $d_{30} = (m_8' \cdot m_4 \cdot m_2' \cdot m_1') + (m_8' \cdot m_4 \cdot m_2 \cdot m_1') + (m_8 \cdot m_4' \cdot m_2' \cdot m_1) + (m_8 \cdot m_4' \cdot m_2 \cdot m_1)$
- $d_{31} = (m_8' \cdot m_4' \cdot m_2' \cdot m_1) + (m_8' \cdot m_4' \cdot m_2 \cdot m_1) + (m_8' \cdot m_4 \cdot m_2' \cdot m_1) + (m_8' \cdot m_4 \cdot m_2 \cdot m_1) + (m_8 \cdot m_4' \cdot m_2' \cdot m_4') + (m_8 \cdot m_4' \cdot m_2 \cdot m_1') + (m_8 \cdot m_4 \cdot m_2' \cdot m_1')$

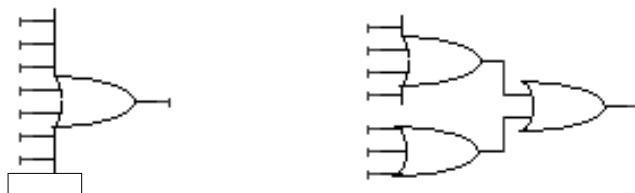

CSE 370 - Spring 2000 - Introduction - 34

Another example

- Door combination lock:
 - punch in 3 values in sequence and the door opens; if there is an error the lock must be reset; once the door opens the lock must be reset
 - inputs: sequence of input values, reset
 - outputs: door open/close
 - memory: must remember combination
or always have it available as an input

Implementation in software

```
integer combination_lock ( ) {
    integer v1, v2, v3;
    integer error = 0;
    static integer c[3] = 3, 4, 2;

    while (!new_value( ));
    v1 = read_value( );
    if (v1 != c[1]) then error = 1;

    while (!new_value( ));
    v2 = read_value( );
    if (v2 != c[2]) then error = 1;

    while (!new_value( ));
    v3 = read_value( );
    if (v2 != c[3]) then error = 1;

    if (error == 1) then return(0); else return (1);
}
```

Implementation as a sequential digital system

■ Encoding:

- ┆ how many bits per input value?
- ┆ how many values in sequence?
- ┆ how do we know a new input value is entered?
- ┆ how do we represent the states of the system?

■ Behavior:

- ┆ clock wire tells us when it's ok to look at inputs (i.e., they have settled after change)
- ┆ sequential: sequence of values must be entered
- ┆ sequential: remember if an error occurred
- ┆ finite-state specification

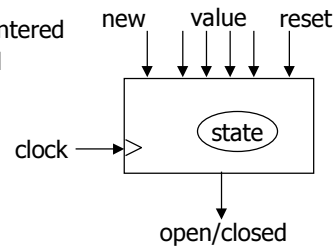

CSE 370 - Spring 2000 - Introduction - 37

Sequential example (cont'd): abstract control

■ Finite-state diagram

- ┆ states: 5 states
 - ┆ represent point in execution of machine
 - ┆ each state has outputs
- ┆ transitions: 6 from state to state, 5 self transitions, 1 global
 - ┆ changes of state occur when clock says it's ok
 - ┆ based on value of inputs
- ┆ inputs: reset, new, results of comparisons
- ┆ output: open/closed

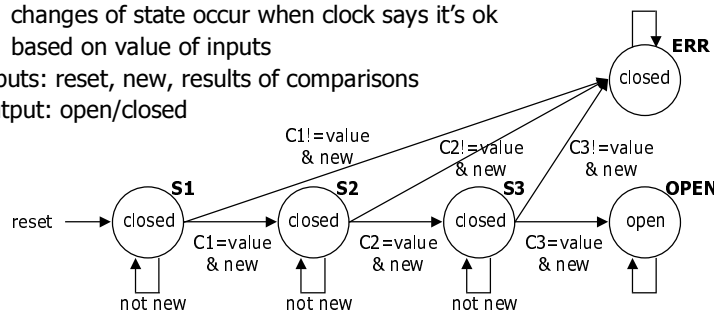

CSE 370 - Spring 2000 - Introduction - 38

Sequential example (cont'd): data-path vs. control

- Internal structure
 - ┆ data-path
 - | storage for combination
 - | comparators
 - ┆ control
 - | finite-state machine controller
 - | control for data-path
 - | state changes controlled by clock

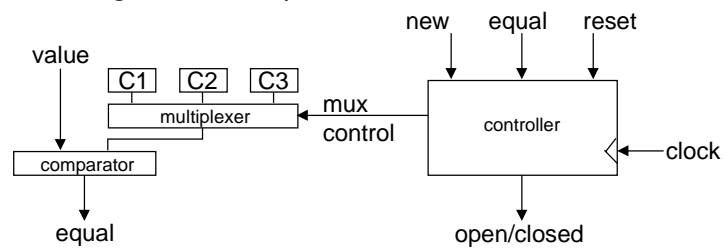

CSE 370 - Spring 2000 - Introduction - 39

Sequential example (cont'd): finite-state machine

- Finite-state machine
 - ┆ refine state diagram to include internal structure

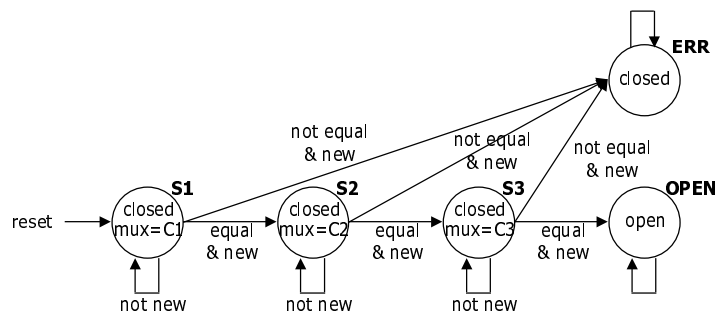

CSE 370 - Spring 2000 - Introduction - 40

Sequential example (cont'd): finite-state machine

Finite-state machine

- generate state table (much like a truth-table)

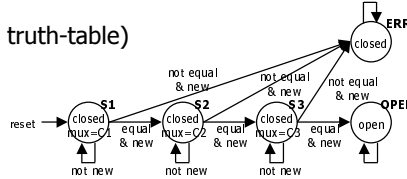

reset	new	equal	state	next state	mux	open/closed
1	-	-	-	S1	C1	closed
0	0	-	S1	S1	C1	closed
0	1	0	S1	ERR	-	closed
0	1	1	S1	S2	C2	closed
0	0	-	S2	S2	C2	closed
0	1	0	S2	ERR	-	closed
0	1	1	S2	S3	C3	closed
0	0	-	S3	S3	C3	closed
0	1	0	S3	ERR	-	closed
0	1	1	S3	OPEN	-	open
0	-	-	OPEN	OPEN	-	open
0	-	-	ERR	ERR	-	closed

CSE 370 - Spring 2000 - Introduction - 41

Sequential example (cont'd): encoding

Encode state table

- state can be: S1, S2, S3, OPEN, or ERR
 - needs at least 3 bits to encode: 000, 001, 010, 011, 100
 - and as many as 5: 00001, 00010, 00100, 01000, 10000
 - choose 4 bits: 0001, 0010, 0100, 1000, 0000
- output mux can be: C1, C2, or C3
 - needs 2 to 3 bits to encode
 - choose 3 bits: 001, 010, 100
- output open/closed can be: open or closed
 - needs 1 or 2 bits to encode
 - choose 1 bits: 1, 0

CSE 370 - Spring 2000 - Introduction - 42

Sequential example (cont'd): encoding

■ Encode state table

- state can be: S1, S2, S3, OPEN, or ERR
 - ┆ choose 4 bits: 0001, 0010, 0100, 1000, 0000
- output mux can be: C1, C2, or C3
 - ┆ choose 3 bits: 001, 010, 100
- output open/closed can be: open or closed
 - ┆ choose 1 bits: 1, 0

reset	new	equal	state	next state	mux	open/closed	
1	-	-	-	0001	001	0	
0	0	-	0001	0001	001	0	
0	1	0	0001	0000	-	0	good choice of encoding!
0	1	1	0001	0010	010	0	
0	0	-	0010	0010	010	0	
0	1	0	0010	0000	-	0	mux is identical to last 3 bits of state
0	1	1	0010	0100	100	0	
0	0	-	0100	0100	100	0	
0	1	0	0100	0000	-	0	open/closed is identical to first bit of state
0	1	1	0100	1000	-	1	
0	-	-	1000	1000	-	1	
0	-	-	0000	0000	-	0	

CSE 370 - Spring 2000 - Introduction - 43

Sequential example (cont'd): controller implementation

■ Implementation of the controller

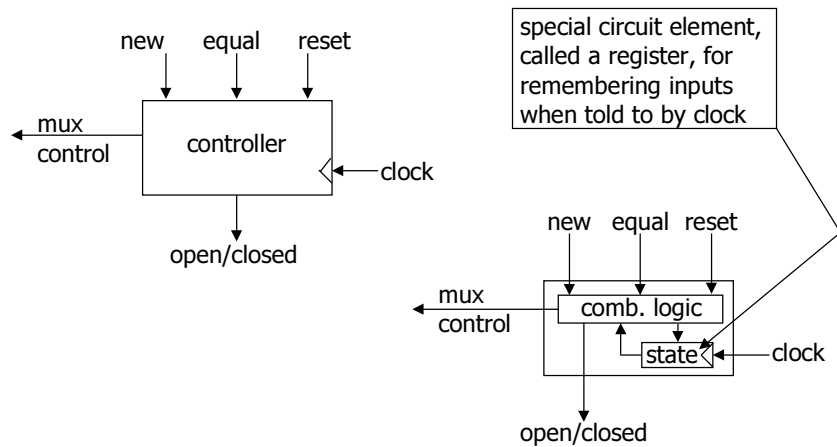

CSE 370 - Spring 2000 - Introduction - 44

Design hierarchy

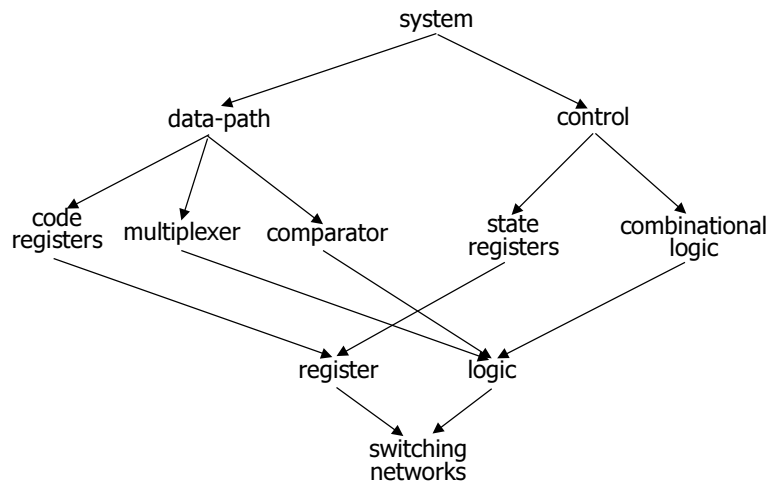

CSE 370 - Spring 2000 - Introduction - 45

Summary

- That was what the entire course is about
 - converting solutions to problems into combinational and sequential networks effectively organizing the design hierarchically
 - doing so with a modern set of design tools that lets us handle large designs effectively
 - taking advantage of optimization opportunities
- Now lets do it again
 - this time we'll take nine weeks

CSE 370 - Spring 2000 - Introduction - 46