

CSE 369 QUIZ 3

Name: _____
Student ID Number: _____

Please do not turn the page until instructed.

Instructions

- This quiz contains 7 pages, including this cover page. You may use the backs of the pages for scratch work.
- Please clearly indicate (box, circle) your final answer.
- The quiz is closed book and closed notes.
- Please silence and put away all cell phones and other mobile or noise-making devices.
- Remove all hats, headphones, and watches.
- You have 60 minutes to complete this quiz.

Advice

- Read questions carefully before starting. Read *all* questions first and start where you feel the most confident to maximize the use of your time.
- There may be partial credit for incomplete answers; please show your work.
- Relax. You are here to learn.

Question	Points	Score
(1) Lightning Round	16	
(2) Analysis & Design	15	
(3) Module Design	15	
Total:	46	

Question 1: Lightning Round [16 pts]

- (A) True or False: The number of rows in a truth table depends only on the number of inputs to the logic function. [1 pts]

- (B) Name one of the 2-input “universal” logic gates discussed in class. [1 pts]

- (C) A K-map is used to perform logic simplification and generates what type of two-level Boolean expression? [1 pts]

- (D) True or False: The input of a positive edge-triggered DFF must remain stable from the positive edge of the clock through the CLK-to-Q delay. [1 pts]

- (E) True or False: In a Synchronous Digital System (SDS), we only need to know the setup time, hold time, and CLK-to-Q delay constants to ensure correct behavior. [1 pts]

- (F) True or False: In a circuit where all inputs and outputs are registered, the *critical path* is the path with the longest delay between any two registers in the circuit. [1 pts]

- (G) True or False: A synchronous reset signal causes the value of the register to be reset when the reset signal is asserted. [1 pts]

- (H) Sequential logic (e.g., registers) timing must not violate the setup and hold time constraints within a clock period. Write out the inequality used to verify the hold and setup time constraints. [2 pts]

- (I) Finite State Machines (FSMs), as studied in this class (Mealy machines) are defined by what three items? [3 pts]

- (J) How many state bits are required to represent a state machine with S states? [1 pts]

- (K) What computational building block or routing element can be used to implement arbitrary N -input logic functions? [1 pts]

- (L) An LFSR (Linear Feedback Shift Register) often uses a two-input logic gate to produce the feedback input in the shift register. How does the choice of logic gate and its input bits affect the output sequence of the LFSR? [2 pts]

Question 2: Analysis & Design - TMR [15 pts]

Triple Modular Redundancy (TMR) is a common technique for making a circuit fault tolerant. A TMR-based circuit performs the same computation in three identical and independent circuits before outputting a result that is agreed upon by at least two of the three circuits (i.e., the majority result).

Part 1 What is the minimum clock period achievable by the non-TMR circuit below? The Inputs and Results blocks are n-bit registers. [3 pts]

Assume $t_{setup} = 10\text{ ns}$, $t_{hold} = 5\text{ ns}$, $t_{C2Q} = 8\text{ ns}$, and $t_{ALU} = 50\text{ ns}$.

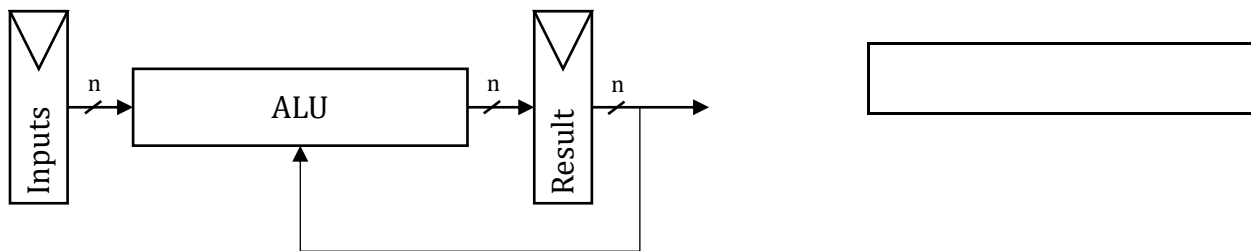

Part 2 The circuit diagram below shows the circuit above with TMR added. The Error Logic block takes n-bit ALU results A, B, and C as inputs and produces two outputs: a 1-bit Error signal that is captured by a register and a k-bit signal that is sent to the Result Logic block. The Result Logic block takes the k-bit signal from the Error Logic block and ALU results A, B, and C as inputs and produces the n-bit Result signal that is captured into a register.

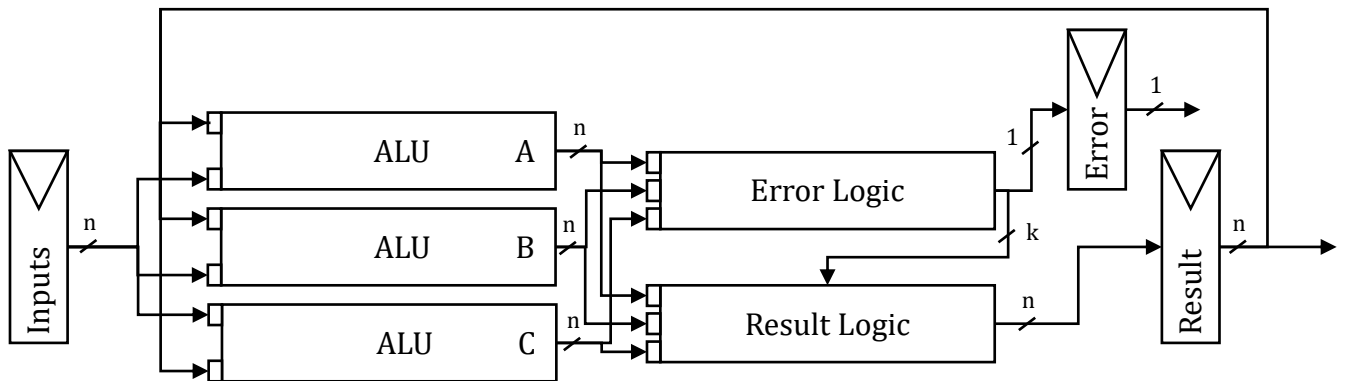

What is the minimum clock period achievable by the TMR circuit above? The Inputs and Results blocks are registers. [4 pts]

Assume $t_{setup} = 10\text{ ns}$, $t_{hold} = 5\text{ ns}$, $t_{C2Q} = 8\text{ ns}$, $t_{ALU} = 50\text{ ns}$, $t_{Error} = 12\text{ ns}$, $t_{Result} = 15\text{ ns}$.

Part 3 The TMR-based design in Part 2 has an Error Logic block to detect a failure in one of the ALUs. The block takes ALU results A, B, and C as inputs and outputs a **1-bit Error signal**, which has a value of 1 if the result of any ALU does not match the result of any other ALU. Assume the ALUs produce **n-bit** results. *Implement the Error Logic block's Error Bit functionality from the TMR circuit in Part 2 (draw the circuit diagram).* [8 pts]

You can freely use 2:1 muxes, 1:2 demuxes, 2- or 3-input logic gates, the constants **0** and **1**, and the following logic blocks:

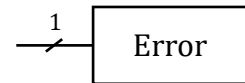
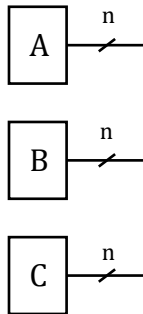
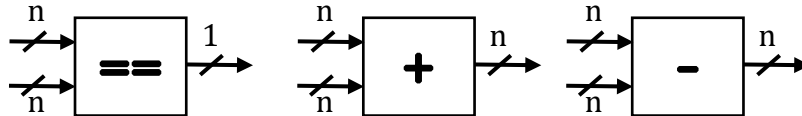

Question 3: Module Design – Up/Down Counter [15 pts]

An n-bit Up/Down Counter is a counter that supports both increment and decrement operations.

The Up/Down Counter has the following interface:

- **up** (input, 1-bit): increments counter by 1 when raised
- **down** (input, 1-bit): decrements counter by 1 when raised
- **count** (output, n-bits): current value of counter
- **clock** (input): clock signal for sequential logic
- **reset** (input, 1-bit): synchronous reset, resets counter to 0 when raised

reset has priority over **up** and **down**, and the **up** and **down** signals may be raised at the same time.

Part 1 Complete the following table describing the functionality of the Up/Down Counter. **next count** is the next value of the counter. The current count is given by the variable C. You may use the values 0, 1, and X (logical don't care), along with the variable C in expressions in the table. [5 pts]

Note: There may be more rows than are required to fully specify the functionality.

count	reset	up	down	next count
C				
C				
C				
C				
C				
C				
C				
C				

Part 2 Implement the Up/Down Counter described above (draw the circuit diagram). You can freely use 4:1 and 2:1 muxes, 1:2 and 1:4 demuxes, 2-input logic gates, the constants **0** and **1**, and the logic blocks given below. The Reg block is a collection of **n** 1-bit DFF's that share the same clock and collectively hold an n-bit vector. *Clearly label all five of the module's interface signals in your circuit diagram.* [10 pts]

