

CSE 369 QUIZ 2

Name: _____
Student ID
Number: _____

Please do not turn the page until 12:20.

Instructions

- This quiz contains 4 pages, including this cover page. You may use the backs of the pages for scratch work.
- Please clearly indicate (box, circle) your final answer.
- The quiz is closed book and closed notes.
- Please silence and put away all cell phones and other mobile or noise-making devices.
- Remove all hats, headphones, and watches.
- You have 30 (+5) minutes to complete this quiz.

Advice

- Read questions carefully before starting. Read *all* questions first and start where you feel the most confident to maximize the use of your time.
- There may be partial credit for incomplete answers; please show your work.
- Relax. You are here to learn.

Question	Points	Score
(1) SL & Timing	6	
(2) FSM Implementation	10	
(3) FSM Design	12	
Total:	28	

Question 1: Sequential Logic & Timing [6 pts]

Consider the following circuit diagram with a clock period of 100 ns (10^{-9} s), $t_{\text{setup}} = 12$ ns, $t_{\text{hold}} = 6$ ns, $t_{\text{C2Q}} = 10$ ns, and $t_{\text{XOR}} = 20$ ns. Assume that In is connected to an asynchronous input and can change at any point during a clock period (in the range $[0, 100]$ ns).

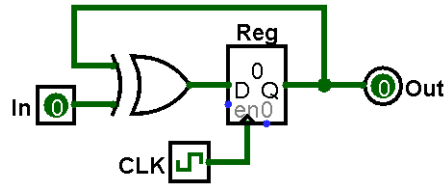

- (A) Calculate the earliest time in a clock period where changing In will cause a setup violation. *Your answer should be between 0 and 100 ns, inclusive.* [3 pts]

- (B) Calculate the latest time in a clock period where changing In will cause a hold violation (in the *next* clock period). *Your answer should be between 0 and 100 ns, inclusive.* [3 pts]

Question 2: Finite State Machine Implementation [10 pts]

(A) Fill in the provided truth table based on the FSM shown. [2 pts]

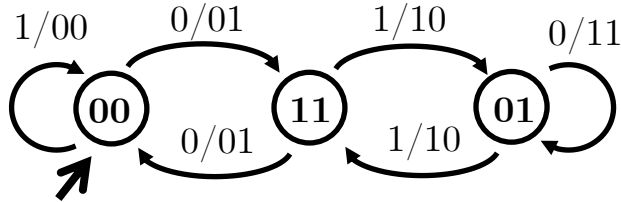

PS ₁	PS ₀	In	NS ₁	NS ₀	Out ₁	Out ₀
0	0	0	1	1		
0	0	1	0	0	0	0
0	1	0			1	1
0	1	1	1	1	1	0
1	0	0	X	X	X	X
1	0	1	X	X		
1	1	0	0	0	0	1
1	1	1			1	0

(B) Complete the circuit diagram below using *minimal logic* based on the truth table shown below. Use only 2-input logic gates. [8 pts]

PS	In ₁	In ₀	NS	Out
0	0	0	1	1
0	0	1	0	1
0	1	0	1	0
0	1	1	X	X
1	0	0	X	X
1	0	1	0	0
1	1	0	1	1
1	1	1	1	1

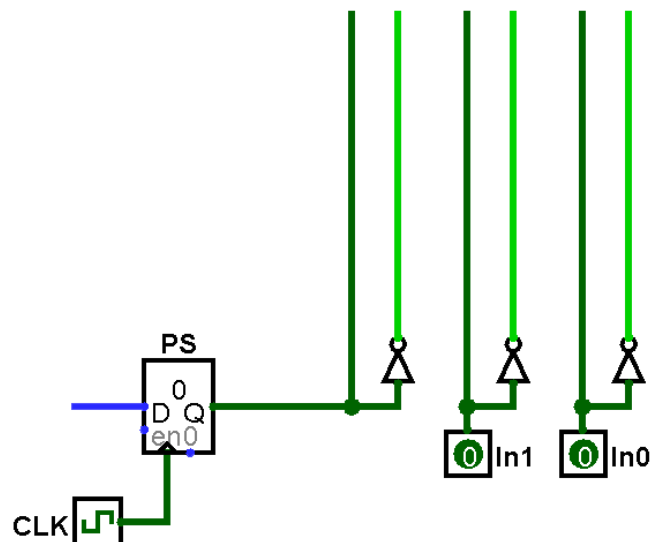
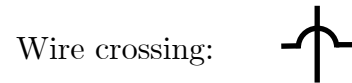

Question 3: Finite State Machine Design [12 pts]

The following FSM is a string manipulator; it outputs a modified version of its stream of inputs:

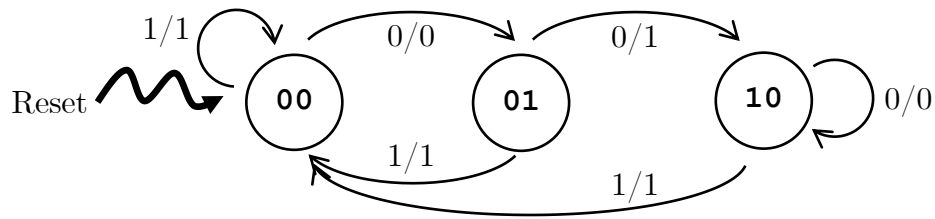

- (A) Assume we pass the following stream of inputs (left-to-right) immediately after resetting the FSM. What is the corresponding stream of outputs? [4 pt]

Input: 0 1 0 0 1 0 0 0

Output:

- (B) As *briefly* as you can, describe how this FSM manipulates its input stream. [3 pt]

- (C) Complete the testbench `initial` block to *thoroughly* test the state diagram. You need to fill in all bolded blanks. You are welcome to fill out the Verilog comments to help you keep track of state, but these will not be graded. [5 pts]

```

initial begin
                                In <= 0;      // state: 00
    @(posedge clk); In <= _____; // state: _____
    @(posedge clk); In <= _____; // state: _____
    @(posedge clk); In <= _____; // state: _____
    @(posedge clk); In <= 1;      // state: _____
    @(posedge clk); In <= 1;      // state: _____
    @(posedge clk); $stop();
end
  
```