

CSE 369 QUIZ 2

Name: _____
Student ID
Number: _____

Please do not turn the page until 11:30.

Instructions

- This quiz contains 4 pages, including this cover page. You may use the backs of the pages for scratch work.
- Please clearly indicate (box, circle) your final answer.
- The quiz is closed book and closed notes.
- Please silence and put away all cell phones and other mobile or noise-making devices.
- Remove all hats, headphones, and watches.
- You have 25 minutes to complete this quiz.

Advice

- Read questions carefully before starting. Read *all* questions first and start where you feel the most confident to maximize the use of your time.
- There may be partial credit for incomplete answers; please show your work.
- Relax. You are here to learn.

Question	Points	Score
(1) SL & Timing	6	
(2) FSM Implementation	10	
(3) FSM Design	10	
Total:	26	

Question 1: Sequential Logic & Timing [6 pts]

Consider the following circuit diagram with $t_{\text{setup}} = 12 \text{ ns}$ (10^{-9} s), $t_{\text{hold}} = 18 \text{ ns}$, $t_{\text{C2Q}} = 8 \text{ ns}$, $t_{\text{AND}} = 25 \text{ ns}$, and $t_{\text{NOR}} = 20 \text{ ns}$. Assume that In changes **9 ns** after every clock trigger.

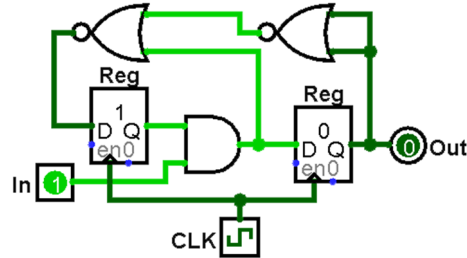

- (A) Calculate the **minimum clock period** that will allow the circuit to function correctly. Make sure to *include units*. [3 pts]

$$t_{\text{period}} \geq$$

- (B) If we swap out our AND gate for one with a different combinational delay, what is the **minimum t_{AND}** that will allow the circuit to function correctly. Make sure to *include units*. [3 pts]

$$t_{\text{AND}} \geq$$

Question 2: Finite State Machine Implementation [10 pts]

(A) Fill in the provided truth table based on the FSM shown. [2 pts]

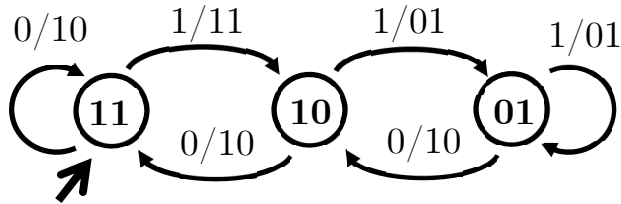

PS ₁	PS ₀	In	NS ₁	NS ₀	Out ₁	Out ₀
0	0	0	X	X	X	X
0	0	1	X			X
0	1	0	1	0	1	0
0	1	1		1	0	
1	0	0	1	1	1	0
1	0	1	0			1
1	1	0	1	1	1	0
1	1	1		0	1	

(B) Complete the circuit diagram below using *minimal logic* based on the truth table shown below. You are welcome to use 2- and 3-input logic gates. [8 pts]

PS	In ₁	In ₀	NS	Out
0	0	0	0	0
0	0	1	1	1
0	1	0	0	0
0	1	1	X	X
1	0	0	1	1
1	0	1	0	1
1	1	0	1	1
1	1	1	X	X

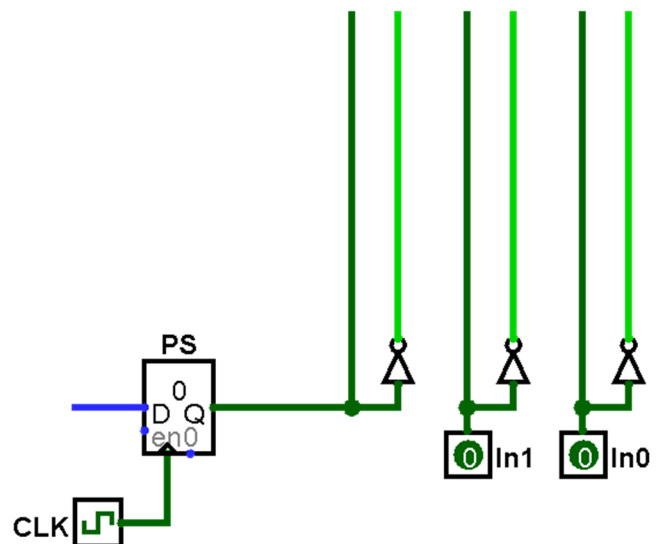
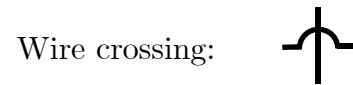

Question 3: Finite State Machine Design [10 pts]

Justin has built a *secret elevator* that goes directly to his office! It is controlled by 3-state rocker switch (see diagram below) that passes the input signals up (U) and down (D). The output is whether the elevator doors are open (1) or closed (0).

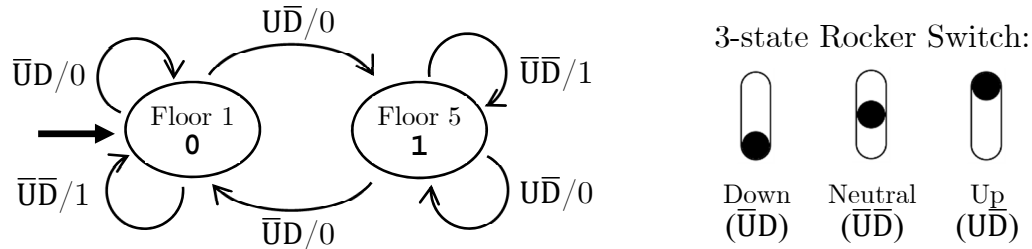

- (A) How many total rows are in the truth table for the 3-way switch FSM? How many of the rows are filled with Don't Cares? [2 pt]

Rows:	Don't Care Rows:
-------	------------------

- (B) Complete the testbench `initial` block to *thoroughly* test the state diagram. Even though they may be unnecessary, please fill in all blanks. You are welcome to fill out the Verilog comments to help you keep track of state, but these will not be graded. [5 pts]

```

initial begin
    U <= 0;    D <= 1;    // state: 0
    @(posedge clk); U <= ____; D <= ____; // state: ____
    @(posedge clk); U <= 1;    D <= 0;    // state: ____
    @(posedge clk); U <= ____; D <= ____; // state: ____
    @(posedge clk); U <= 0;    D <= 1;    // state: ____
    @(posedge clk); U <= ____; D <= ____; // state: ____
    @(posedge clk);
    $stop();
end
    
```

- (C) The rocker switch imposes a physical constraint: when going between the up and down states, you *must* pass through the neutral state. Does your testbench above conform to this constraint or not? Explain *briefly*. [3 pt]