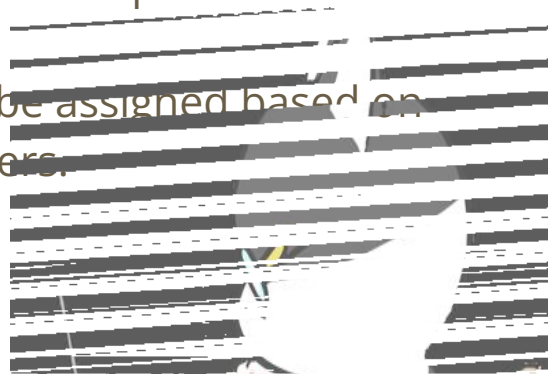

Section 5

— Finite State Machines —

Or “Fun” State Machines with Isabel & Packard

Administrivia

- **Lab 5:** Report due next Wednesday (5/6) @ 2:30 pm, demo by last OH on Friday (5/8), but expected during your assigned slot.
 - ⚠ This lab is harder than previous labs ⚠
 - Resource Utilization Extra Credit - moving on from gate level optimization to number of registers and adaptive logic units.
 - Resource Utilization Leaderboard - Extra credit will not be assigned based on the leaderboard, it is just a fun way to compare with peers.
- **Lab 6:** Report due 5/13, demo by last OH on 5/15.
 - ⚠ This lab is a LOT harder than Lab 5 ⚠



New SystemVerilog Commands

New SystemVerilog Commands

- `enum` – create an enumerated type with a restricted set of named values.
 - Basic usage: `enum <original type> {<name_list>} <vars>;`
 - `<original type>` must be wide enough to support the length of `<name_list>`; if omitted, defaults to `int` type.
 - By default, names in the `<name_list>` are assigned consecutive values starting from 0.
 - Can explicitly assign values using `name=<value>` syntax.

New SystemVerilog Commands

- `enum` – create an enumerated type with a restricted set of named values.
 - Basic usage: `enum <original type> {<name_list>} <vars>;`
 - `<original type>` must be wide enough to support the length of `<name_list>`; if omitted, defaults to `int` type.
 - By default, names in the `<name_list>` are assigned consecutive values starting from `0`.
 - Can explicitly assign values using `name=<value>` syntax.
- Example: `enum logic [1:0] {S0, S1, S11=2'b11} ps, ns;`
 - `S0` assigned `2'b00`, `S1` assigned `2'b01`.
 - Two variables declared that can *only* take on the values `S0`, `S1`, and `S11` (no `2'b10`).

New SystemVerilog Commands

- Ternary operator – shorthand for an `if-else` statement using the syntax `<cond> ? <then> : <else>` (same syntax as C).
 - Same syntax as C/C++.
 - Never necessary to use, just results in more compact code.
 - Very useful in combinational logic for next state and output logic.

New SystemVerilog Commands

- Ternary operator – shorthand for an if-else statement using the syntax `<cond> ? <then> : <else>` (same syntax as C).
 - Same syntax as C/C++.
 - Never necessary to use, just results in more compact code.
 - Very useful in combinational logic for next state and output logic.
- Examples:
 - `case` (ps)

```
S0: ns = w ? S1 : S0;  
S1: ns = w ? S11 : S0;  
S11: ns = w ? S11 : S0;  
endcase
```
 - `assign` `HEX0 = SW[0] ? leds : 7'b1111111;`

Finite State Machine Implementation

FSM Implementation Notes

- The **state diagram design** is *by far* the most important part! The SystemVerilog implementation process is fairly mechanical.
 - It is worth it to spend time on a good FSM drawing. It will help prevent a lot of debugging.

FSM Implementation Notes

- The **state diagram design** is *by far* the most important part! The SystemVerilog implementation process is fairly mechanical.
 - It is worth it to spend time on a good FSM drawing. It will help prevent a lot of debugging.
- Module design notes:
 - Must have a clock input (e.g., `clk`, `clock`, `CLOCK_50`) for sequential elements.
 - Should have a reset input (e.g., `rst`, `reset`) for “initialization.”
 - Must have a present state (`ps`); recommended to also have a next state (`ns`).

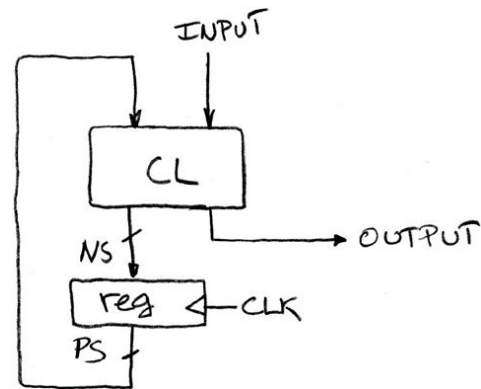

FSM Design Pattern

- 1) *// State Encodings and Variables*
 - a) `enum` to define `ps` and `ns`
- 2) *// Next State Logic (ns)*
 - a) `always_comb` or `assign` with *blocking* assignments (=)
- 3) *// Output Logic*
 - a) `assign` or `always_comb` with *blocking* assignments (=)
 - b) Mealy-type output example: `assign out = (ps == S1) & in;`
- 4) *// State Update Logic (ps) - including reset*
 - a) `always_ff` with *non-blocking* assignments (<=)

Exercise 1

- The following FSM represents a *Red Light, Green Light* game, where a player is only allowed to move forward ($M=1$) when the light is green ($L=1$). Here, the player wins (output $W=1$) after successfully moving twice; moving when the light is red ($L=0$) results in returning to the start

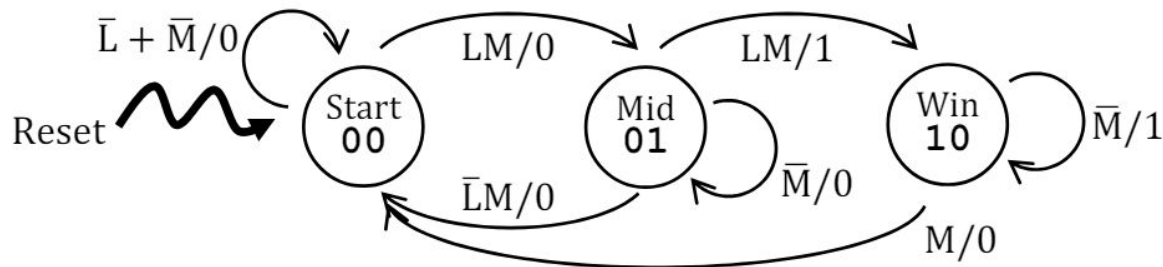

- Implement this system in a module called **light_game**.

Exercise 1 (Solution)

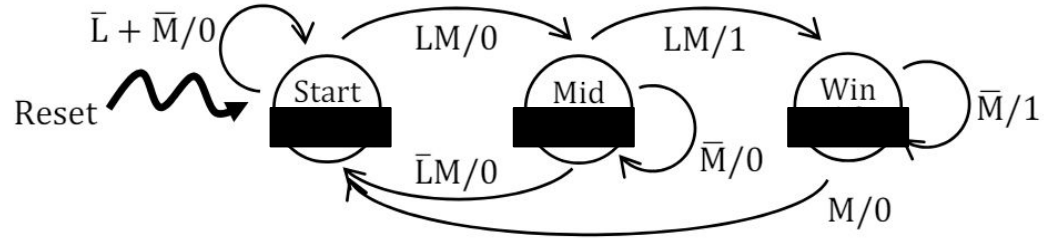

- Module outline

```
module light_game (input logic clk, reset, M, L, output logic W);
```

```
endmodule // light_game
```

Exercise 1 (Solution)

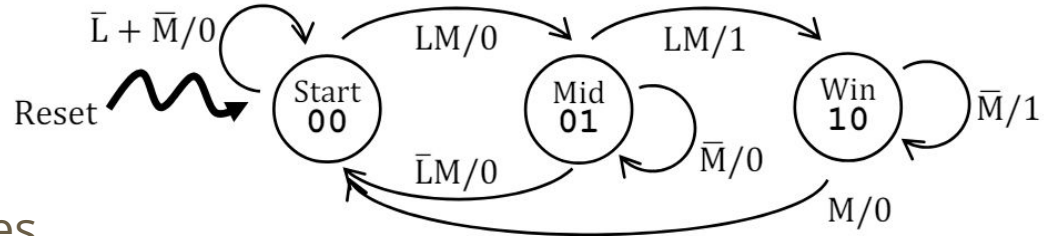

- State encodings and variables

```
module light_game (input logic clk, reset, M, L, output logic W);
```

```
  enum logic [1:0] {Start, Mid, Win} ps, ns;
```

```
endmodule // light_game
```

Exercise 1 (Solution)

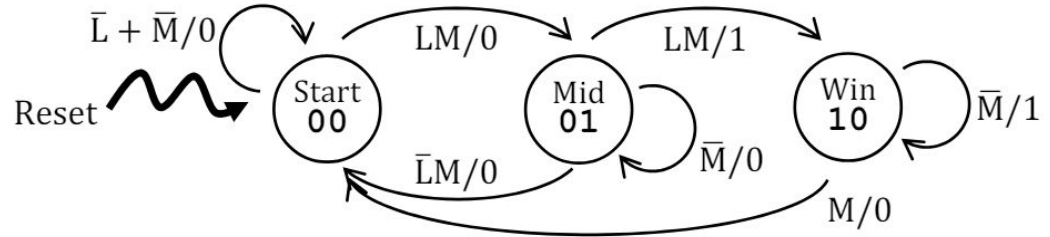

- Next state logic

```
module light_game (input logic clk, reset, M, L, output logic W);  
  
    enum logic [1:0] {Start, Mid, Win} ps, ns;  
  
    always_comb  
        case (ps)  
            Start: ns = (L & M) ? Mid : Start;  
            Mid:   ns = (L & M) ? Win : (M ? Start : Mid);  
            Win:   ns = M ? Start : Win;  
        endcase  
  
endmodule // light_game
```

Exercise 1 (Solution)

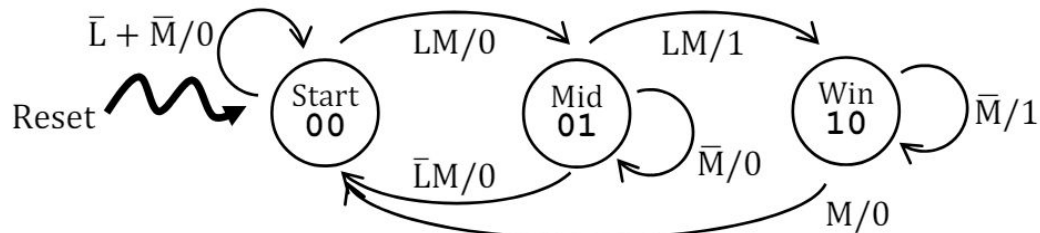

- Output logic

```
module light_game (input logic clk, reset, M, L, output logic W);

    enum logic [1:0] {Start, Mid, Win} ps, ns;

    always_comb
        case (ps)
            Start: ns = (L & M) ? Mid : Start;
            Mid:   ns = (L & M) ? Win : (M ? Start : Mid);
            Win:   ns = M ? Start : Win;
        endcase

    assign W = (ns == Win); // alt: ((ps == Mid) & L & M) |
                          //      ((ps == Win) & ~M)

endmodule // light_game
```

Exercise 1 (Solution)

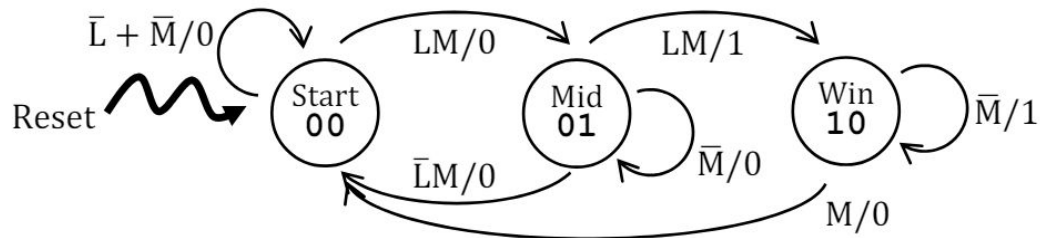

- State update logic

```
module light_game (input logic clk, reset, M, L, output logic W);

    enum logic [1:0] {Start, Mid, Win} ps, ns;

    ... // next state logic
    ... // output logic

    always_ff @(posedge clk)
        if (reset)
            ps <= Start;
        else
            ps <= ns;

endmodule // light_game
```

Exercise 2

- Below is an FSM for a modified vending machine with increased cost of 15¢ for gumballs that also accepting quarters (Q: 25¢); it still does not give change and can only take one coin at a time.

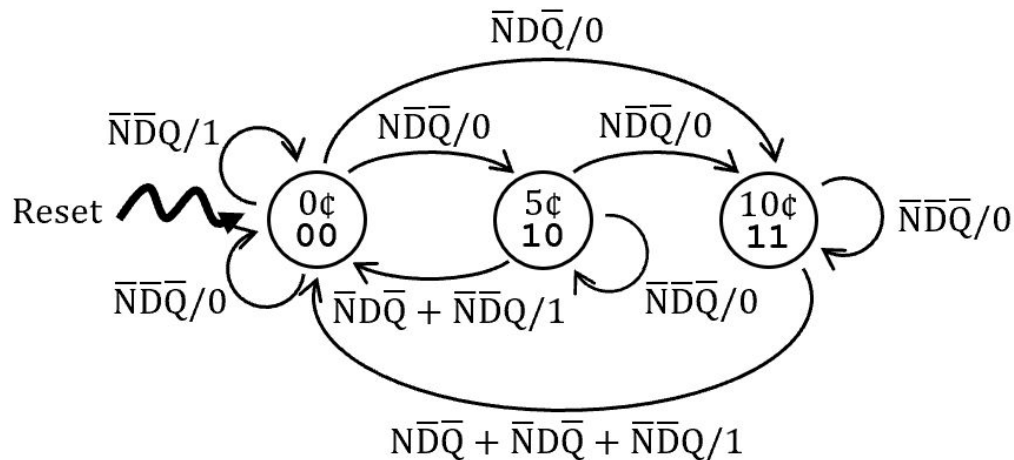

- Implement this system in a module called **vend15**.

Exercise 2 (Solution)

- Module outline

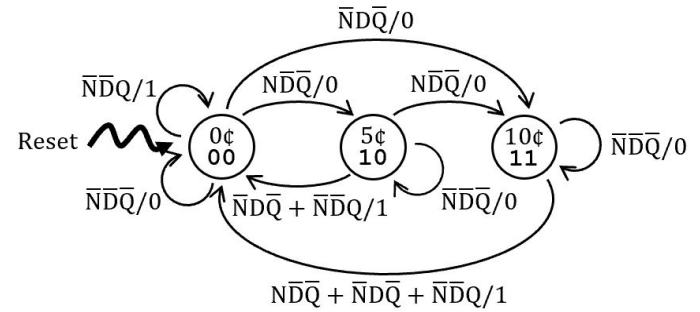

```
module vend15 (input logic clk, reset, N, D, Q, output logic Open);
```

```
endmodule // vend15
```

Exercise 2 (Solution)

- State encodings and variables

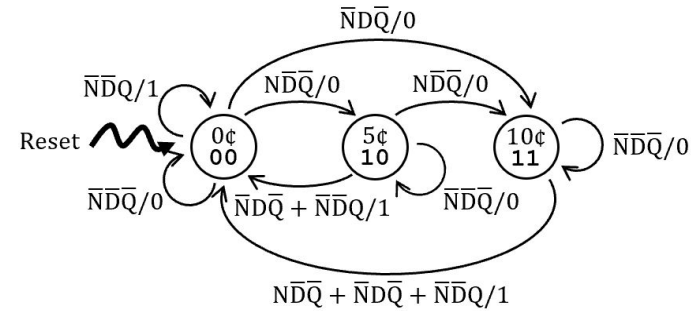

```
module vend15 (input logic clk, reset, N, D, Q, output logic Open);  
    enum logic [1:0] {Zero, Five=2'b10, Ten=2'b11} ps, ns;
```

```
endmodule // vend15
```

Exercise 2 (Solution)

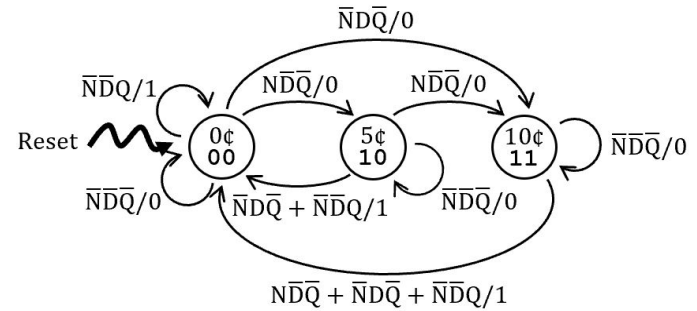

- Next state logic

```
module vend15 (input logic clk, reset, N, D, Q, output logic Open);
  enum logic [1:0] {Zero, Five=2'b10, Ten=2'b11} ps, ns;

  always_comb
  case (ps)
    Zero: case ({N, D, Q})
      3'b000: ns = Zero;
      3'b100: ns = Five;
      3'b010: ns = Ten;
      3'b001: ns = Zero;
      default: ns = ps;
    endcase
    ... // Five and Ten defined similarly
  endcase
endmodule // vend15
```

Exercise 2 (Solution)

- Output logic

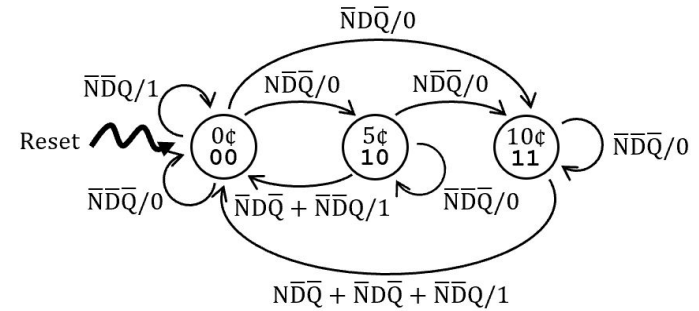

```
module vend15 (input logic clk, reset, N, D, Q, output logic Open);
    enum logic [1:0] {Zero, Five=2'b10, Ten=2'b11} ps, ns;

    ... // next state logic

    assign Open = Q | ((ps != Zero) & D) | ((ps == Ten) & N);

endmodule // vend15
```

Exercise 2 (Solution)

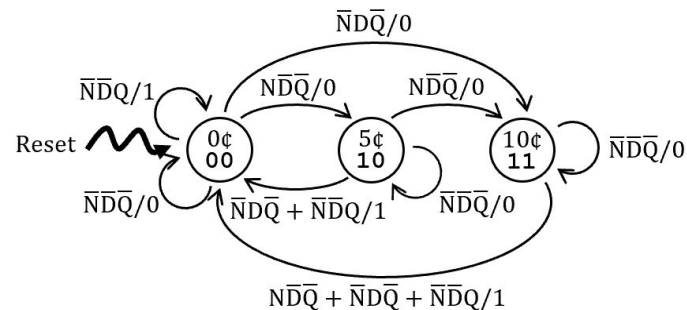

- State update logic

```
module vend15 (input logic clk, reset, N, D, Q, output logic Open);
    enum logic [1:0] {Zero, Five=2'b10, Ten=2'b11} ps, ns;

    ... // next state logic

    assign Open = Q | ((ps != Zero) & D) | ((ps == Ten) & N);

    always_ff @(posedge clk)
        if (reset)
            ps <= Zero;
        else
            ps <= ns;

endmodule // vend15
```

Finite State Machine Testing

FSM Test Bench Notes

- All notes about sequential test benches from last week still apply!
 - Generate a simulated clock (don't use `clock_divider`), start with a reset and define all inputs at $t=0$, add extra delay at end to see the effects of your last input changes.
- To thoroughly test your FSM, need to **take every transition that we care about** (can omit/ignore don't cares).
- Recommended test bench lines in `initial` block:
`<input changes> @(posedge clk); // current state: ???`
- In ModelSim, you should at least add `ps` to waveforms.
 - Could also include `ns` or other signals involved in `ps/ns` computations.

FSM Test Bench Example

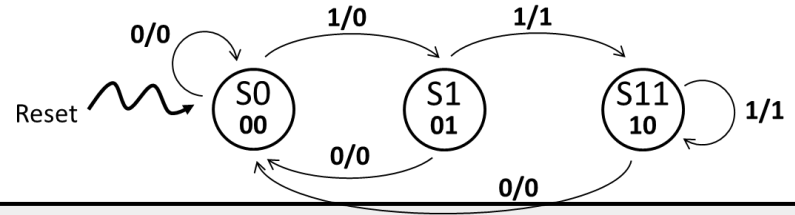

```
// generate test vectors
```

```
initial begin
```

```
  reset <= 1; w <= 0; @(posedge clk); // reset
```

```
  reset <= 0;          @(posedge clk); // curr state: S0
```

```
  $stop; // pause the simulation
```

```
end
```

FSM Test Bench Example

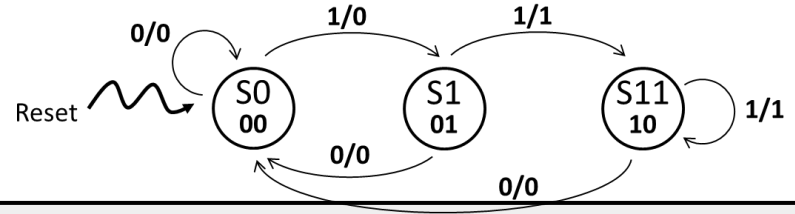

```
// generate test vectors
initial begin
    reset <= 1; w <= 0; @(posedge clk); // reset
    reset <= 0;      @(posedge clk); // curr state: S0
                    w <= 1; @(posedge clk); // curr state: S0
                    w <= 0; @(posedge clk); // curr state: S1
                    w <= 1; @(posedge clk); // curr state: S0
                        @(posedge clk); // curr state: S1
                        @(posedge clk); // curr state: S11
                        @(posedge clk); // curr state: S11
                    w <= 0; @(posedge clk); // curr state: S11
                        @(posedge clk); // curr state: S0 (extra cycle)

    $stop; // pause the simulation
end
```

Exercise 3

- Create a test bench for `vend15` and simulate it in ModelSim.
 - What's the minimum number of clock cycles required to thoroughly test it?

Exercise 3 (Solution)

- Setup clock.

```
module vend15_tb ();  
    ... // signal declarations and dut instantiation  
  
    parameter T = 100;  
    initial  
        clk = 1'b0;  
    always begin  
        #(T/2)  clk <= 1'b0;  
        #(T/2)  clk <= 1'b1;  
    end  
  
endmodule // vend15_tb
```

Exercise 3 (Solution)

- Define `initial` block and add `$stop` system task.

```
module vend15_tb ();  
    ... // signal declarations and dut instantiation  
    ... // clock generation  
  
    initial begin  
  
        $stop;  
    end  
  
endmodule // vend15_tb
```

Exercise 3 (Solution)

- Start with a reset and initialize all inputs.

```
module vend15_tb ();  
    ... // signal declarations and dut instantiation  
    ... // clock generation  
  
    initial begin  
        {reset,N,D,Q} <= 4'b1000; @(posedge clk); // reset  
  
        $stop;  
    end  
  
endmodule // vend15_tb
```

Exercise 3 (Solution)

- Map out a sequence of inputs that would allow us to test every transition.

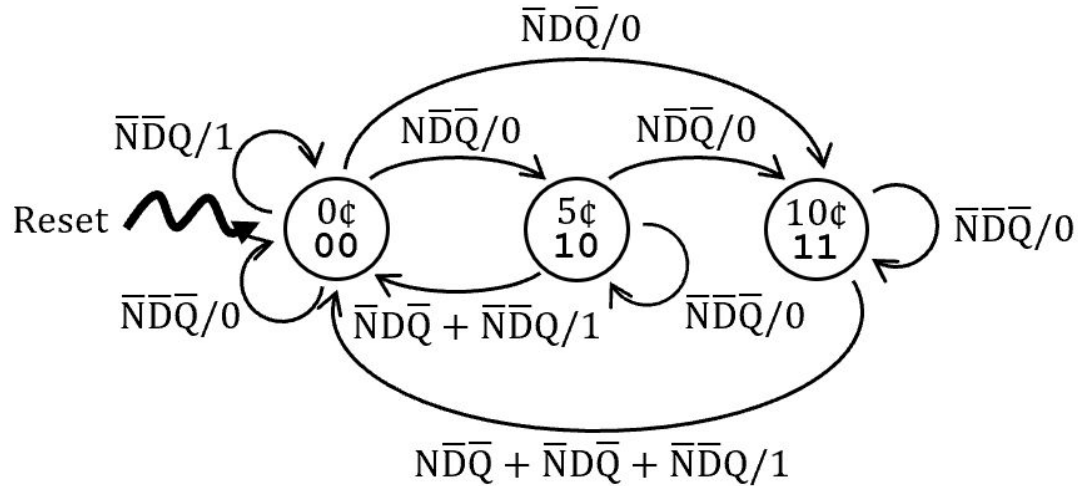

Exercise 3 (Solution)

- Map out a sequence of inputs that would allow us to test every transition.

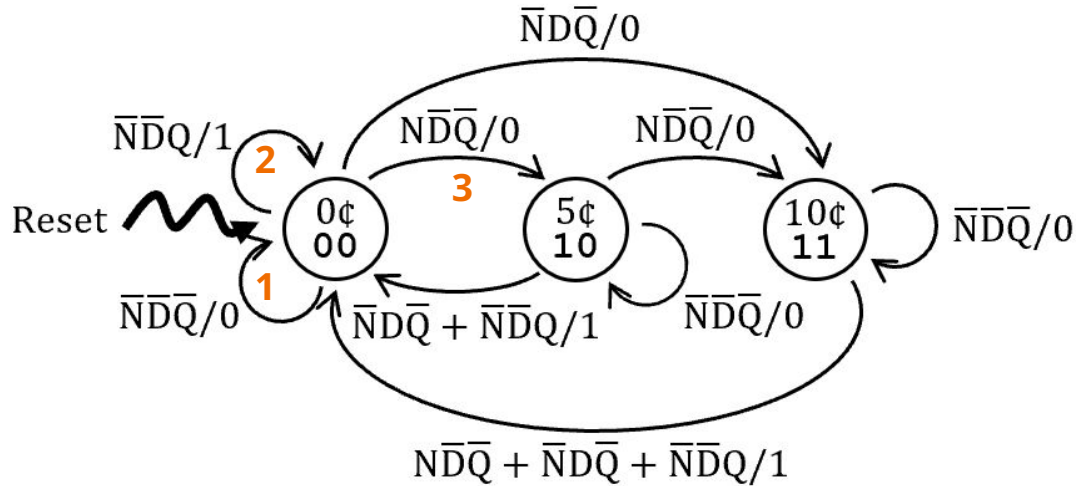

Exercise 3 (Solution)

- Map out a sequence of inputs that would allow us to test every transition.
 - This is just one of many possibilities!

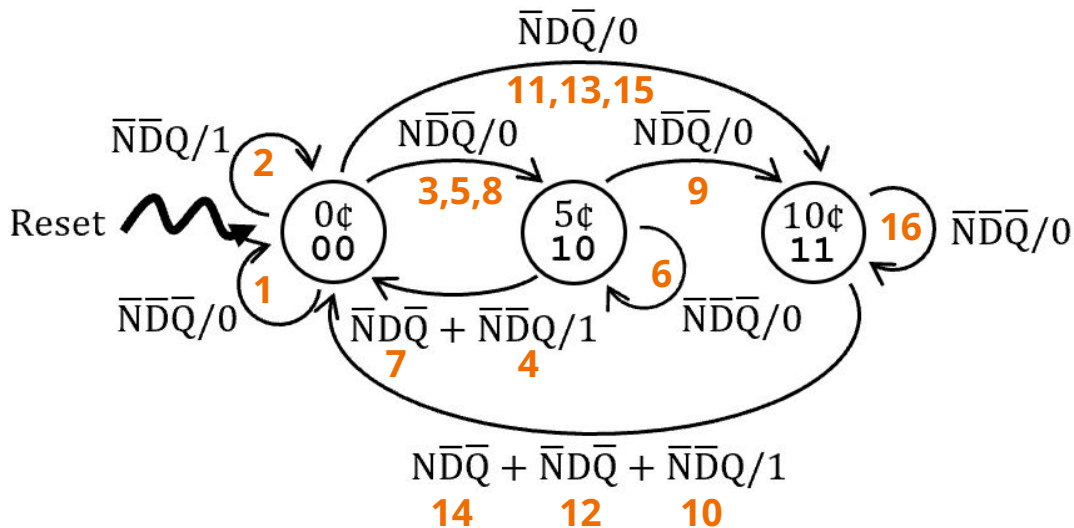

Exercise 3 (Solution)

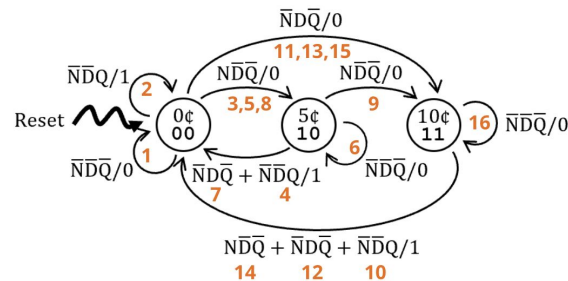

- Add the transitions we mapped out.

```
module vend15_tb ();
... // signal declarations, dut instantiation, clock generation
initial begin
  {reset,N,D,Q} <= 4'b1000; @(posedge clk); // reset
  {reset,N,D,Q} <= 4'b0000; @(posedge clk); // Zero (1)
  {N,D,Q} <= 3'b001; @(posedge clk); // Zero (2)
  {N,D,Q} <= 3'b100; @(posedge clk); // Zero (3)
  {N,D,Q} <= 3'b001; @(posedge clk); // Five (4)
  {N,D,Q} <= 3'b100; @(posedge clk); // Zero (5)
  {N,D,Q} <= 3'b000; @(posedge clk); // Five (6)
  {N,D,Q} <= 3'b010; @(posedge clk); // Five (7)
  {N,D,Q} <= 3'b100; @(posedge clk); // Zero (8)
  {N,D,Q} <= 3'b100; @(posedge clk); // Five (9)
... // continued on next slide
```

Exercise 3 (Solution)

- Add the transitions we mapped out.

```
... // signal declarations, dut instantiation, clock generation
initial begin
    ... // previous clock cycles
        {N,D,Q} <= 3'b001; @(posedge clk); // Ten (10)
        {N,D,Q} <= 3'b010; @(posedge clk); // Zero (11)
                                     @(posedge clk); // Ten (12)
                                     @(posedge clk); // Zero (13)
        {N,D,Q} <= 3'b100; @(posedge clk); // Ten (14)
        {N,D,Q} <= 3'b010; @(posedge clk); // Zero (15)
        {N,D,Q} <= 3'b000; @(posedge clk); // Ten (16)
                                     @(posedge clk); // extra

    $stop;
end
endmodule // vend15_tb
```

Exercise 3 (Solution)

- Simulation results should verify that (1) reset works, (2) the transition between states as expected, and (3) our output matches what we expect.

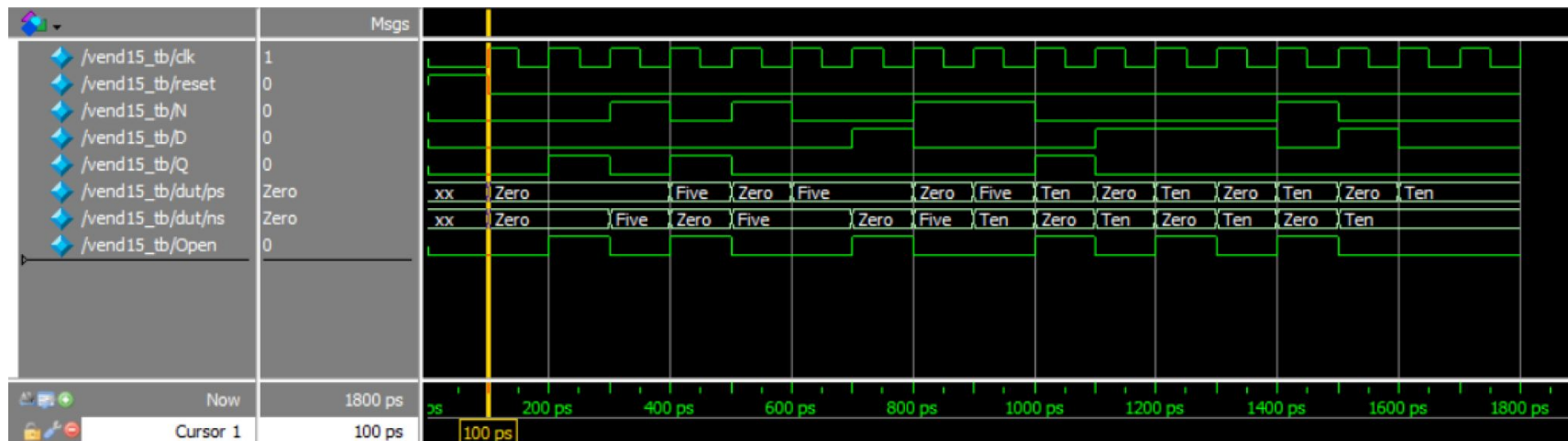

Exercise 3 (Solution)

- Step 1 - Verify the reset behavior.

```
module vend15 (...)  
  ...  
  always_ff @(posedge  
clk)  
    if (reset)  
      ps <= Zero;  
    else  
      ps <= ns;  
  ...  
endmodule // vend15
```

```
module vend15_tb ();  
  ... // signal declarations, dut instantiation, clock generation  
  initial begin  
    {reset,N,D,Q} <= 4'b1000; @(posedge clk); // reset  
    {reset,N,D,Q} <= 4'b0000; @(posedge clk); // Zero (1)  
    ...  
  end  
endmodule
```

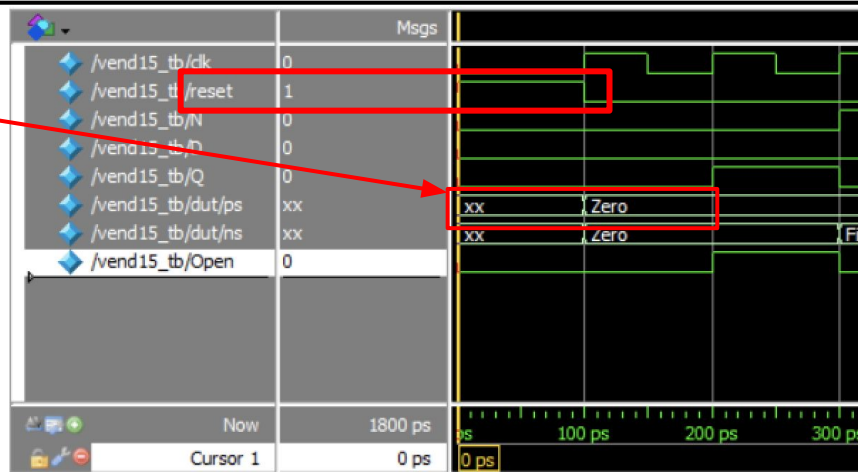

Exercise 3 (Solution)

- Step 2 - Verifying every transition between states as expected.

```
...
initial begin
  {reset,N,D,Q} <= 4'b1000; @(posedge clk); // reset
  {reset,N,D,Q} <= 4'b0000; @(posedge clk); // Zero (1)
  {N,D,Q} <= 3'b001; @(posedge clk); // Zero (2)
  {N,D,Q} <= 3'b100; @(posedge clk); // Zero (3)
  {N,D,Q} <= 3'b001; @(posedge clk); // Five (4)
  {N,D,Q} <= 3'b100; @(posedge clk); // Zero (5)
  {N,D,Q} <= 3'b000; @(posedge clk); // Five (6)
  {N,D,Q} <= 3'b010; @(posedge clk); // Five (7)
  {N,D,Q} <= 3'b100; @(posedge clk); // Zero (8)
  {N,D,Q} <= 3'b100; @(posedge clk); // Five (9)
  {N,D,Q} <= 3'b001; @(posedge clk); // Ten (10)
  {N,D,Q} <= 3'b010; @(posedge clk); // Zero (11)
  {N,D,Q} <= 3'b010; @(posedge clk); // Ten (12)
  {N,D,Q} <= 3'b010; @(posedge clk); // Zero (13)
  {N,D,Q} <= 3'b100; @(posedge clk); // Ten (14)
  {N,D,Q} <= 3'b010; @(posedge clk); // Zero (15)
  {N,D,Q} <= 3'b000; @(posedge clk); // Ten (16)
  ...
end
```

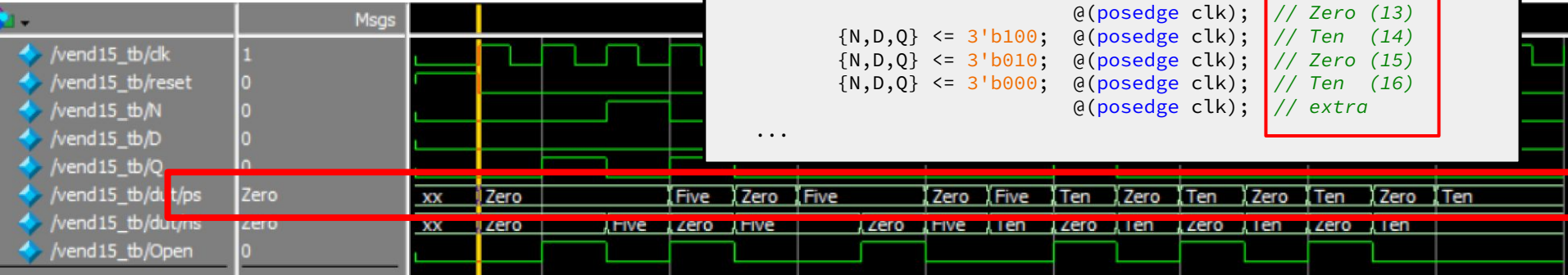

Exercise 3 (Solution)

Transitions that should output 1:

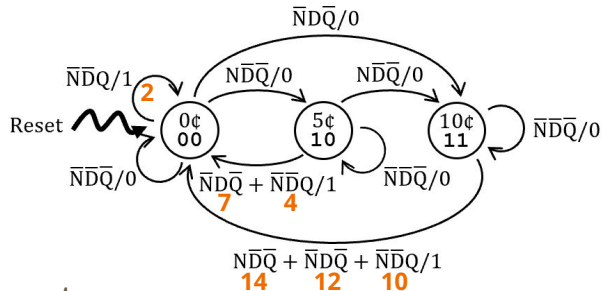

- Step 3 - Verifying our output matches what we expect.

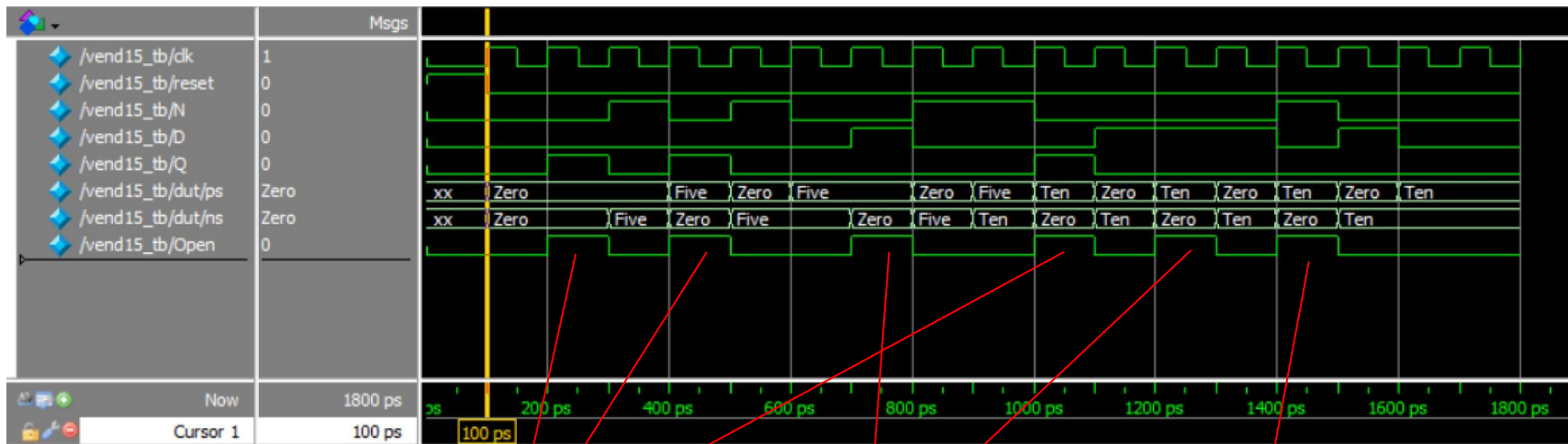

```
assign Open = Q | ((ps != Zero) & D) | ((ps == Ten) & N);
```