

Buffer Overflow

CSE 351 Winter 2024

Instructor:
Justin Hsia

Teaching Assistants:

Adithi Raghavan
Aman Mohammed
Connie Chen
Eyoel Gebre
Jiawei Huang
Malak Zaki
Naama Amiel
Nathan Khuat
Nikolas McNamee
Pedro Amarante
Will Robertson

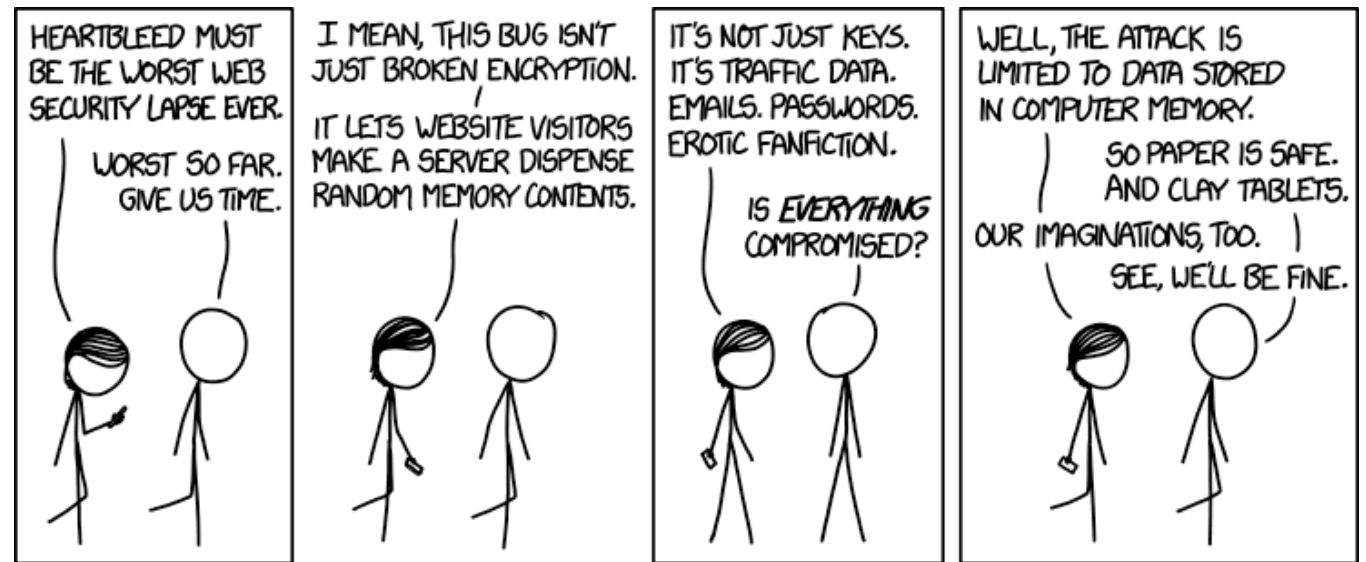

Alt text: I looked at some of the data dumps from vulnerable sites, and it was ... bad. I saw emails, passwords, password hints. SSL keys and session cookies. Important servers brimming with visitor IPs. Attack ships on fire off the shoulder of Orion, c-beams glittering in the dark near the Tannhäuser Gate. I should probably patch OpenSSL.

<http://xkcd.com/1353/>

Relevant Course Information

- ❖ Mid-quarter survey due tonight!
- ❖ HW12 due tonight, HW13 due Wednesday, HW14 due Monday (2/12)
- ❖ Lab 3 released today, due next Friday (2/16)
 - You will have everything you need by the end of this lecture
- ❖ Midterm starts Thursday (Friday lecture is extra support hour)
 - Instructions will be posted on Ed Discussion
 - Gilligan's Island Rule: discuss high-level concepts and give hints, but not solving the problems together
 - Ed Discussion (private posts) and support hours to answer clarifying questions

A detailed, colorful micrograph of a microchip die, showing a complex grid of circuitry and various colored regions (purple, blue, yellow, green, red) representing different functional blocks and interconnects.

Buffer Overflow

Lesson Summary (1/3)

- ❖ A **buffer** is an array that holds temporary data (*e.g.*, user/file/network input)
- ❖ **Buffer overflow** is writing past the end of the buffer
 - Common in C/Unix/Linux due to lack of bounds checking
 - Vulnerable functions include gets, strcpy, scanf, fscanf, sscanf
- ❖ Buffer overflow exploit: **stack smashing**
 - Overflow local array to alter stack contents
 - Commonly used to alter procedure return address

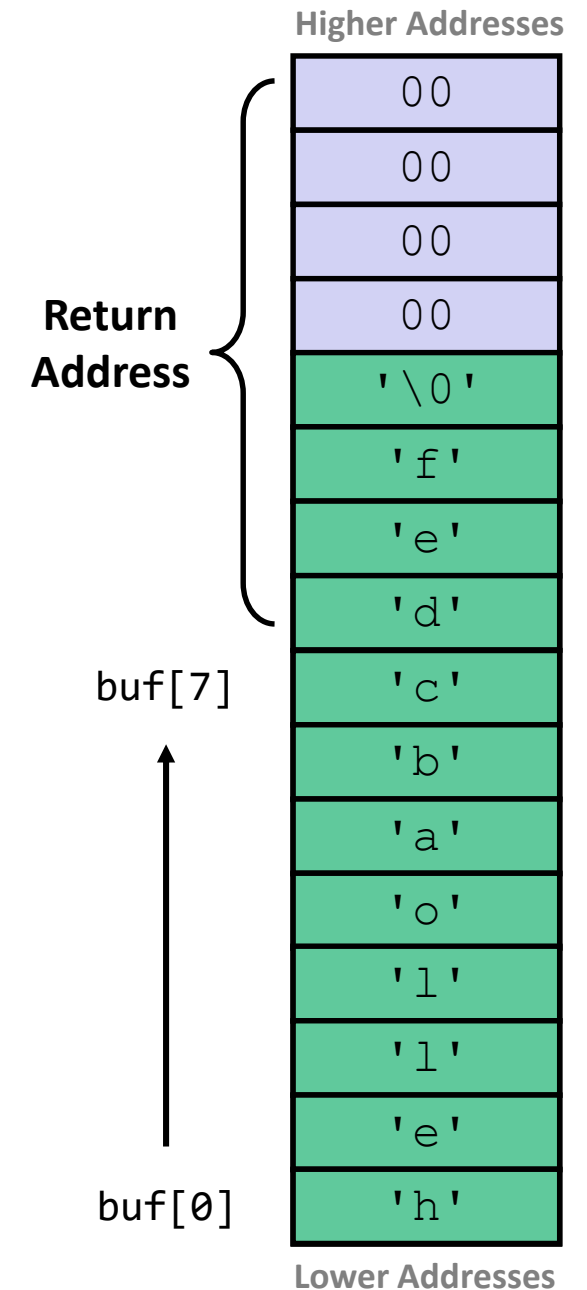

Lesson Summary (2/3)

- ❖ A **buffer** is an array that holds temporary data (*e.g.*, user/file/network input)
- ❖ **Buffer overflow** is writing past the end of the buffer
 - Common in C/Unix/Linux due to lack of bounds checking
 - Vulnerable functions include `gets`, `strcpy`, `scanf`, `fscanf`, `sscanf`
- ❖ Buffer overflow exploit: **code injection**
 - 1) Put exploit/machine code in buffer
 - 2) Pad to reach stack frame's return address
 - 3) Replace return address with address of the buffer

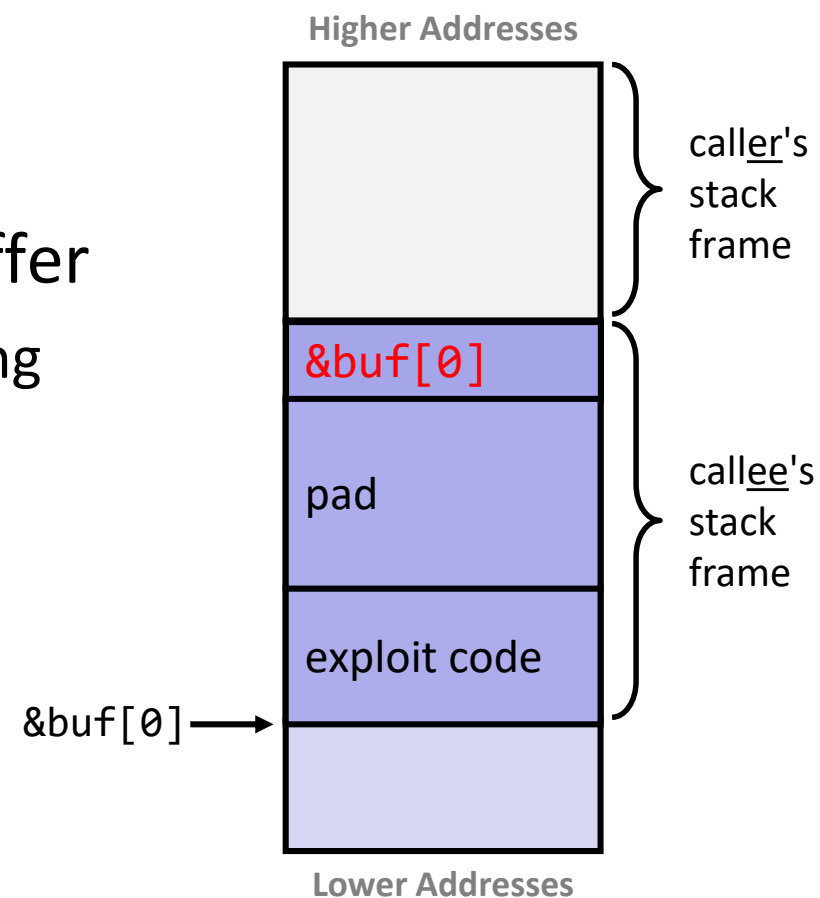

Lesson Summary (3/3)

- ❖ Dealing with buffer overflow attacks
 - Use array bounds checking
 - Manually (*i.e.*, implement yourself) or automatically (*e.g.*, use safe functions or non-C language)
 - Add a stack canary after the buffer
 - Secret value (changes on each execution) that shouldn't change
 - Randomized stack offsets
 - Makes finding the address of exploit code more difficult
 - Non-executable memory regions (*e.g.*, the stack)
 - Prevent exploit code from being placed and executed there

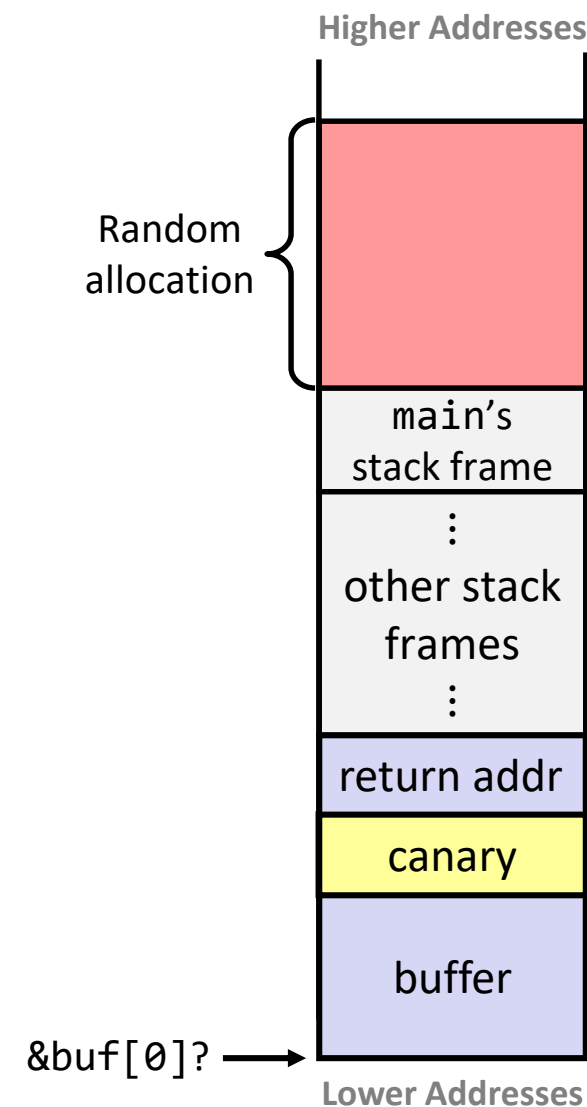

Lesson Q&A

- ❖ Learning Objectives:
 - Define buffer overflow and explain how it occurs.
 - Identify elements of C programs that make them vulnerable to buffer overflow.
 - Identify methods of protecting against buffer overflow.
 - Perform stack smashing and code injection exploits.

- ❖ What lingering questions do you have from the lesson?
 - Chat with your neighbors about the lesson for a few minutes to come up with questions

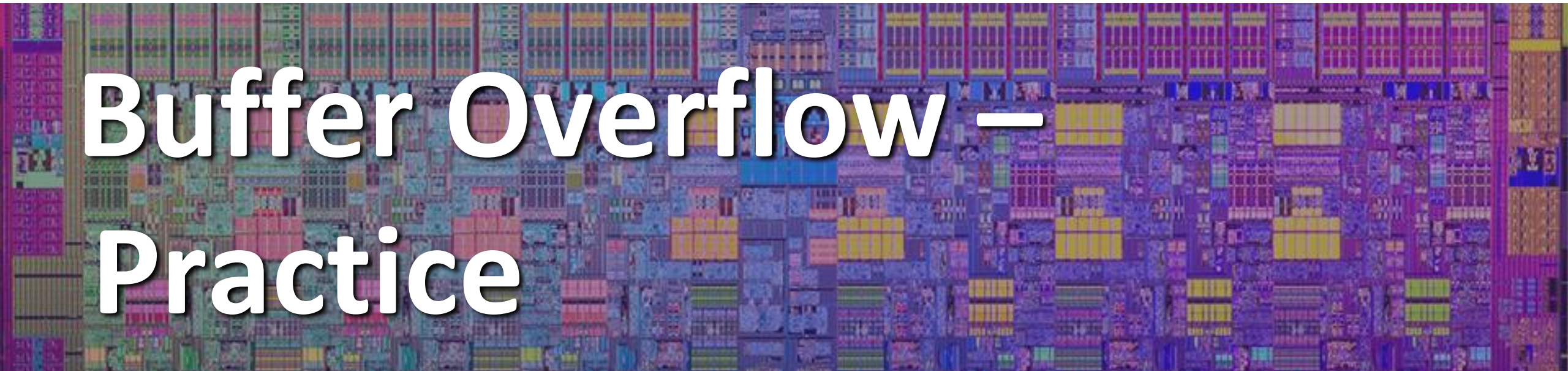
A detailed, colorful micrograph of a microchip die, showing a complex grid of circuitry and various colored regions (purple, blue, yellow, green, red) representing different functional blocks and interconnects.

Buffer Overflow – Practice

Polling Question

- ❖ `smash_me` is vulnerable to stack smashing!
- ❖ What is the minimum number of characters that `gets` must read in order for us to change the return address to a stack address?
 - For example: `(0x 00 00 7f ff ca fe f0 0d)`

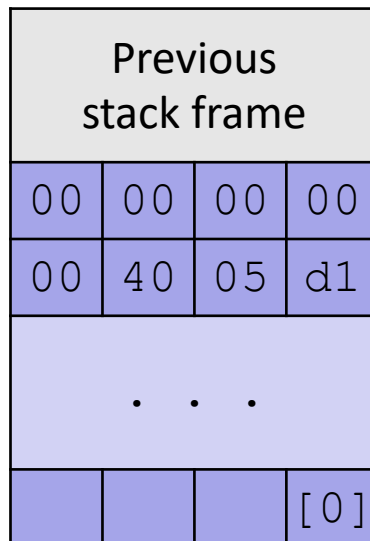

```
smash_me:  
  subq  $0x40, %rsp  
  ...  
  leaq  16(%rsp), %rdi  
  call  gets  
  ...
```

A. 27

B. 30

C. 51

D. 54

E. We're lost...

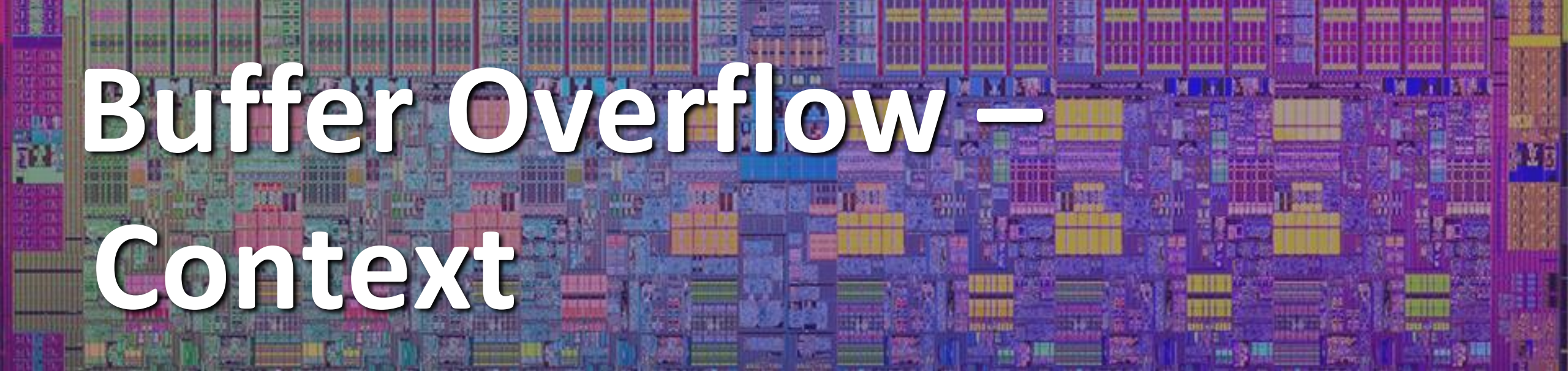

Lab Setup/Demo

- ❖ Printable vs. nonprintable characters (asciitable.com)
 - Input from terminal generally restricted to printable characters (~ 0x20 – 0x7E)
 - Need full range of 1-byte character values (0x00 – 0xFF) for exploits
- ❖ Lab 3 workflow:
 - Design exploit string for task
 - Type out exploit string as printable characters in .txt file
 - Use sendstring to convert .txt → .bytes file
 - Pass .bytes file into bufbomb to be read by Gets()
 - Use GDB to verify that stack is modified as desired

A detailed, colorful image of a microchip die, showing a complex grid of circuitry and various colored regions (purple, blue, yellow, green, red) representing different functional blocks.

Buffer Overflow – Context

Exploits Based on Buffer Overflows

- ❖  Buffer overflow bugs can allow attackers to execute arbitrary code on victim machines 
 - Most commonly executing a “root shell” – terminal with elevated privileges
- ❖ Distressingly common in real programs
 - Original “Internet worm” (1988)
 - Heartbleed (2014, affected 17% of servers) & Cloudbleed (2017)
 - Hacking embedded devices (e.g., cars, smart home devices, Internet of Things)

The Morris Worm (1988)

- ❖ Early versions of the finger server ([fingerd](#)) used gets to read the argument sent by the client
 - e.g., `finger droh@cs.cmu.edu`
- ❖ The Morris Worm attacked `fingerd` server with phony argument:
 - `finger "exploit-code padding new-return-addr"`
 - Exploit code executed a root shell on the victim machine, then scanned for other machines to attack
- ❖ Fallout/legacy ([1989 article](#))
 - Invaded ~6000 computers in hours (10% of the Internet)
 - The author, [Robert Morris](#), was prosecuted
 - First conviction under 1986 Computer Fraud and Abuse Act
 - Now an MIT professor

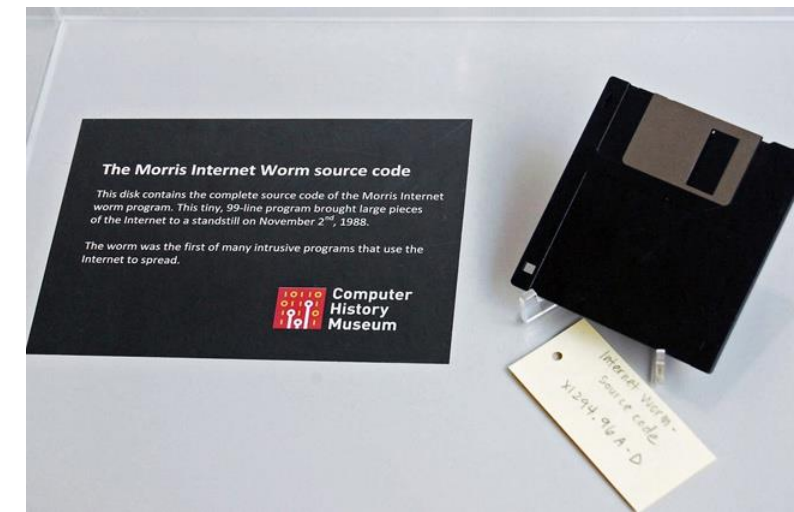

Heartbleed (2014)

HOW THE HEARTBLEED BUG WORKS:

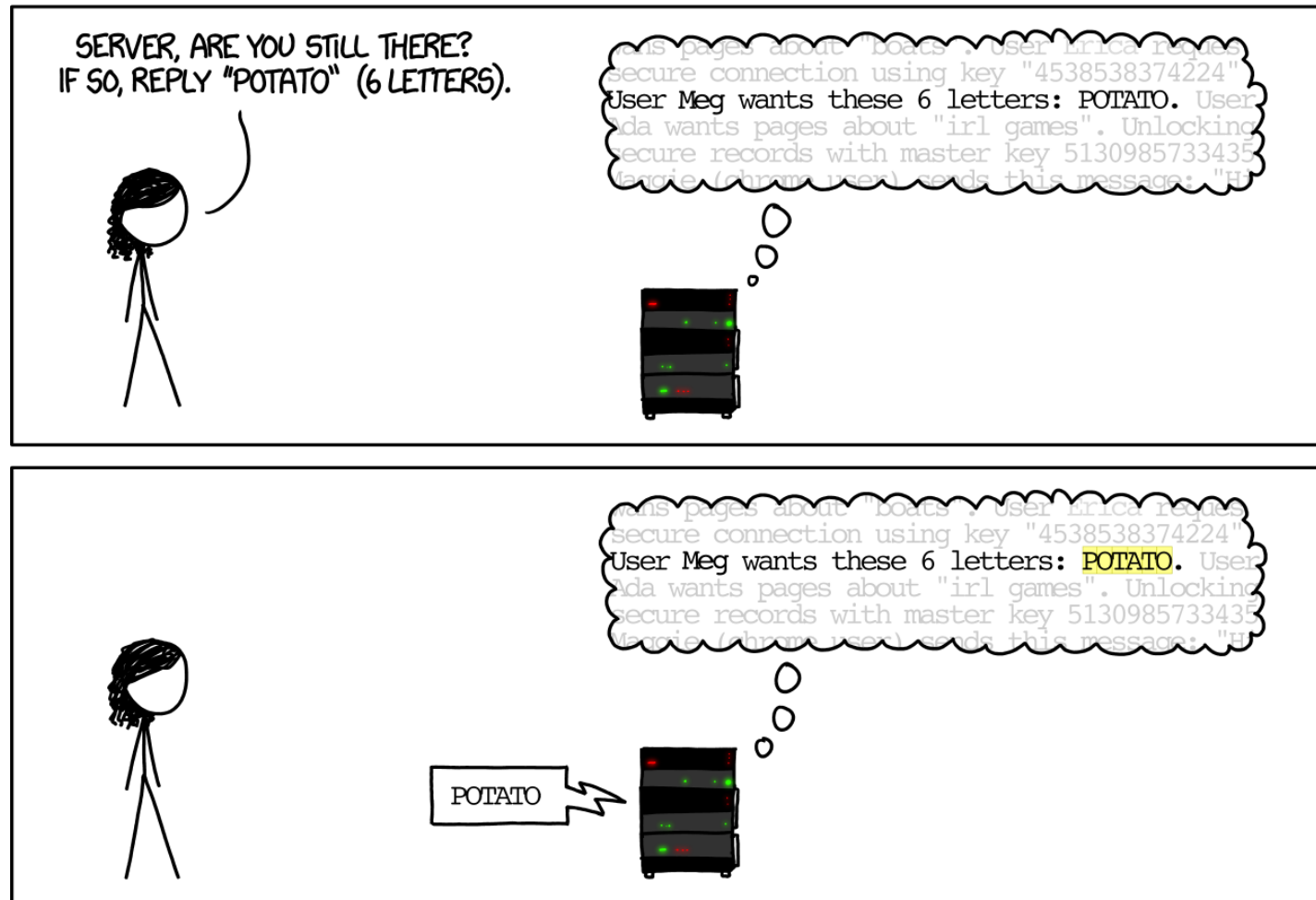

Heartbleed (2014)

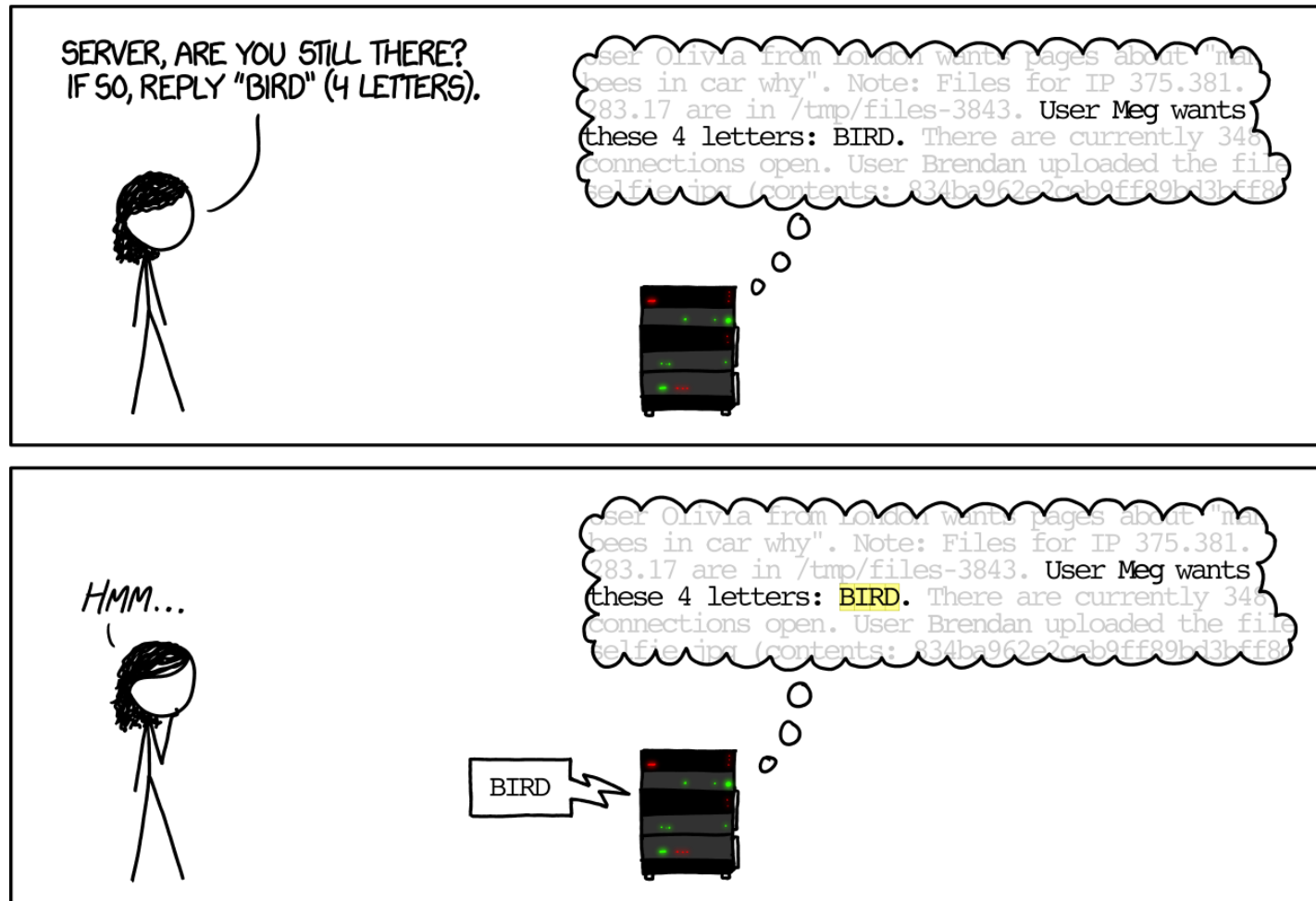

Heartbleed (2014)

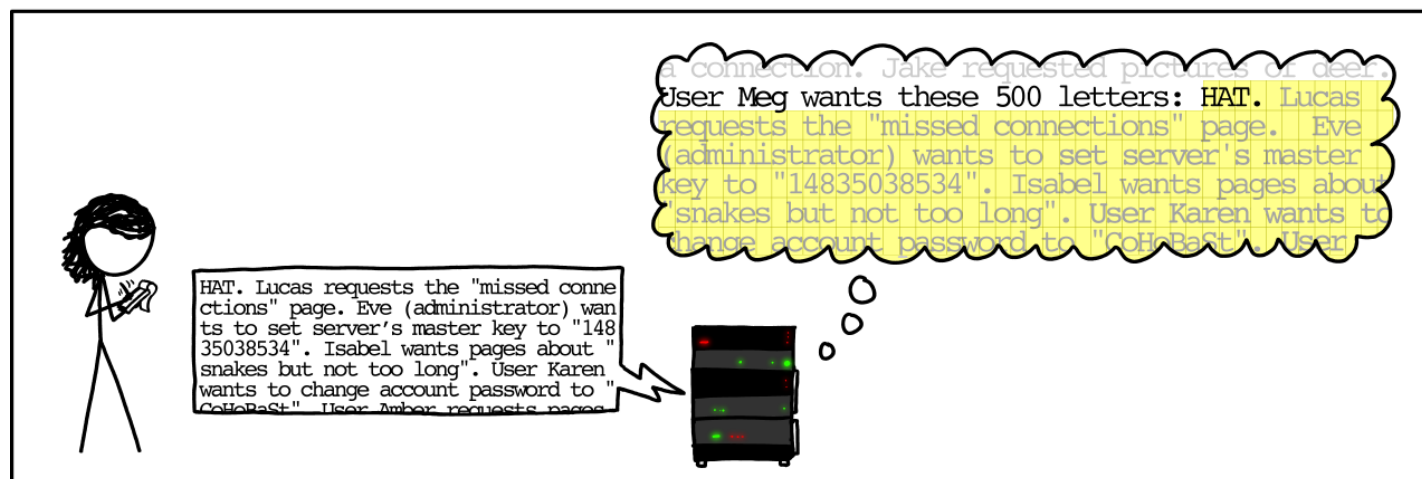
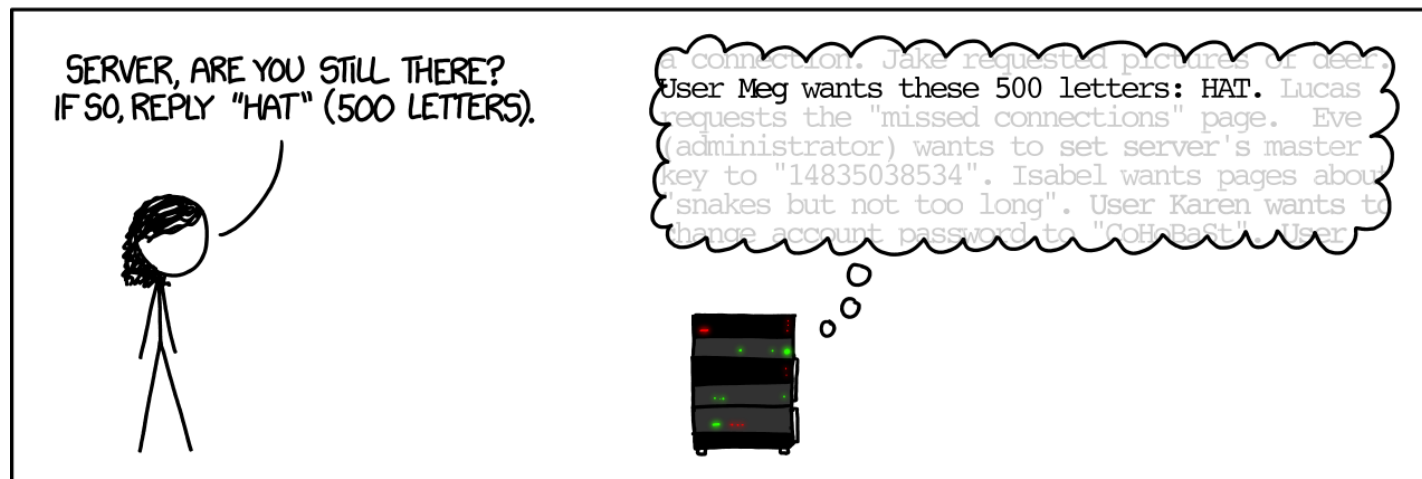

Heartbleed Details

- ❖ Buffer over-read in OpenSSL
 - Open source security library
 - Bug in a small range of versions
- ❖ “Heartbeat” packet: message & length
 - Server echoes back data to match length
 - Allowed attackers to read contents of memory
- ❖ ~17% of Internet affected
 - e.g., Github, Yahoo, Stack Overflow, Amazon Web Services

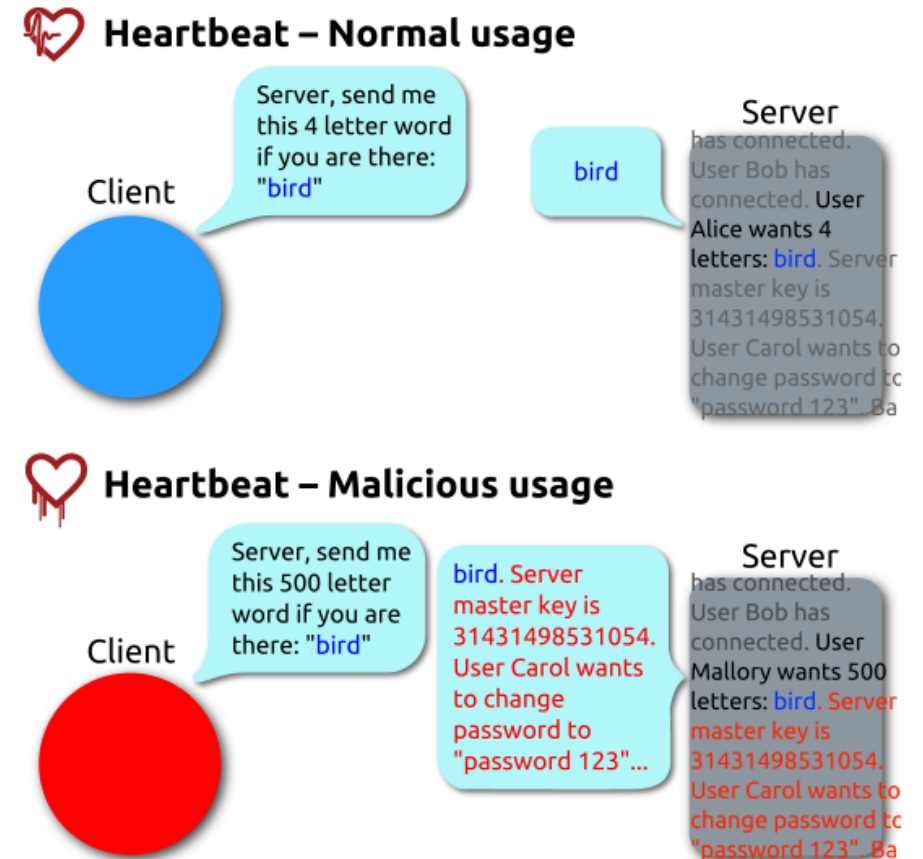

By FenixFeather - Own work, CC BY-SA 3.0,
<https://commons.wikimedia.org/w/index.php?curid=32276981>

Hacking Cars (2010)

- ❖ UW CSE research demonstrated wirelessly hacking a car using buffer overflow
 - <http://www.autosec.org/pubs/cars-oakland2010.pdf>
- ❖ Overwrote the onboard control system's code
 - Disable brakes, unlock doors, turn engine on/off



Hacking DNA Sequencing Tech (2017)

- ❖ UW CSE project: Computer Security and Privacy in [DNA Sequencing](#)
Ney et al. (2017): <https://dnasec.cs.washington.edu/>
 - Potential for malicious code to be encoded in DNA!
 - Attacker can gain control of DNA sequencing machine when malicious DNA is read

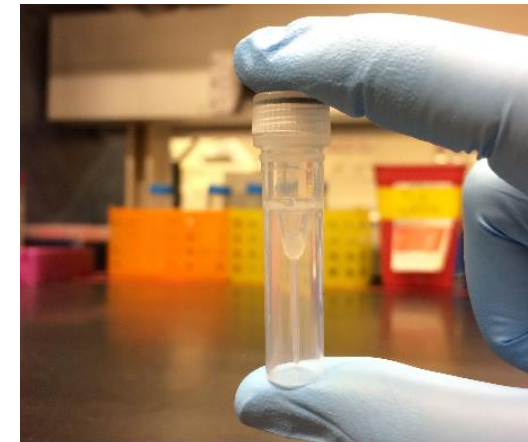
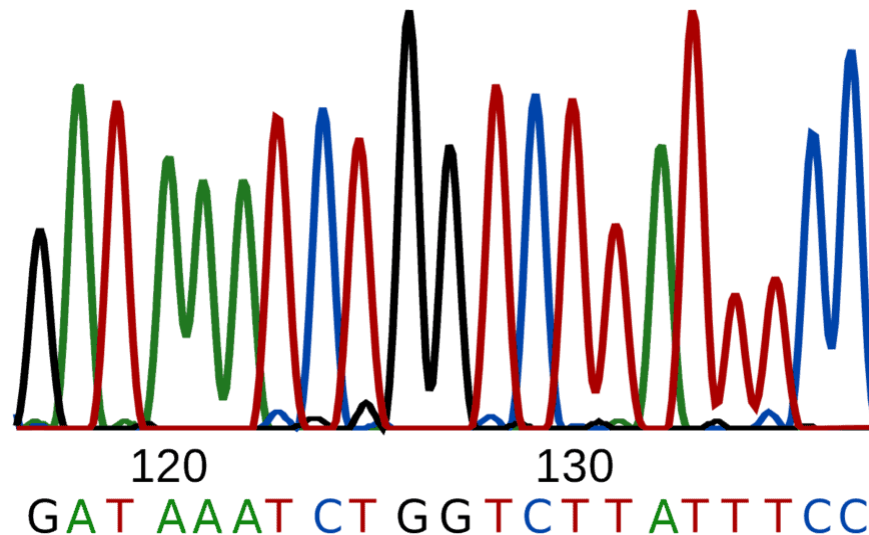

Figure 1: Our synthesized DNA exploit

Think this is cool?

- ❖ Take CSE 484 (Security)
 - Several different kinds of buffer overflow exploits
 - Many ways to counter them
- ❖ Nintendo fun!
 - Using glitches to rewrite code: <https://www.youtube.com/watch?v=TqK-2jUQBUY>
 - Flappy Bird in Mario: <https://www.youtube.com/watch?v=hB6eY73sLV0>

Discussion Questions

- ❖ Discuss the following question(s) in groups of 3-4 students
 - I will call on a few groups afterwards so please be prepared to share out
 - Be respectful of others' opinions and experiences

- ❖ Code injection attacks are a form of “*hacking*” that takes advantage of a *security vulnerability* (e.g., buffer overflow). “Hacking” is now commonplace in society and media.
 - What are some of the possible consequences & objectives of hacking (*i.e.*, to what ends might someone engage in hacking)?
 - What are some reasons why vulnerable systems keep getting connected to the Internet?