

# Virtual Memory III

CSE 351 Winter 2020

## Instructor:

Ruth Anderson

## Teaching Assistants:

Jonathan Chen

Justin Johnson

Porter Jones

Josie Lee

Jeffery Tian

Callum Walker

Eddy (Tianyi) Zhou

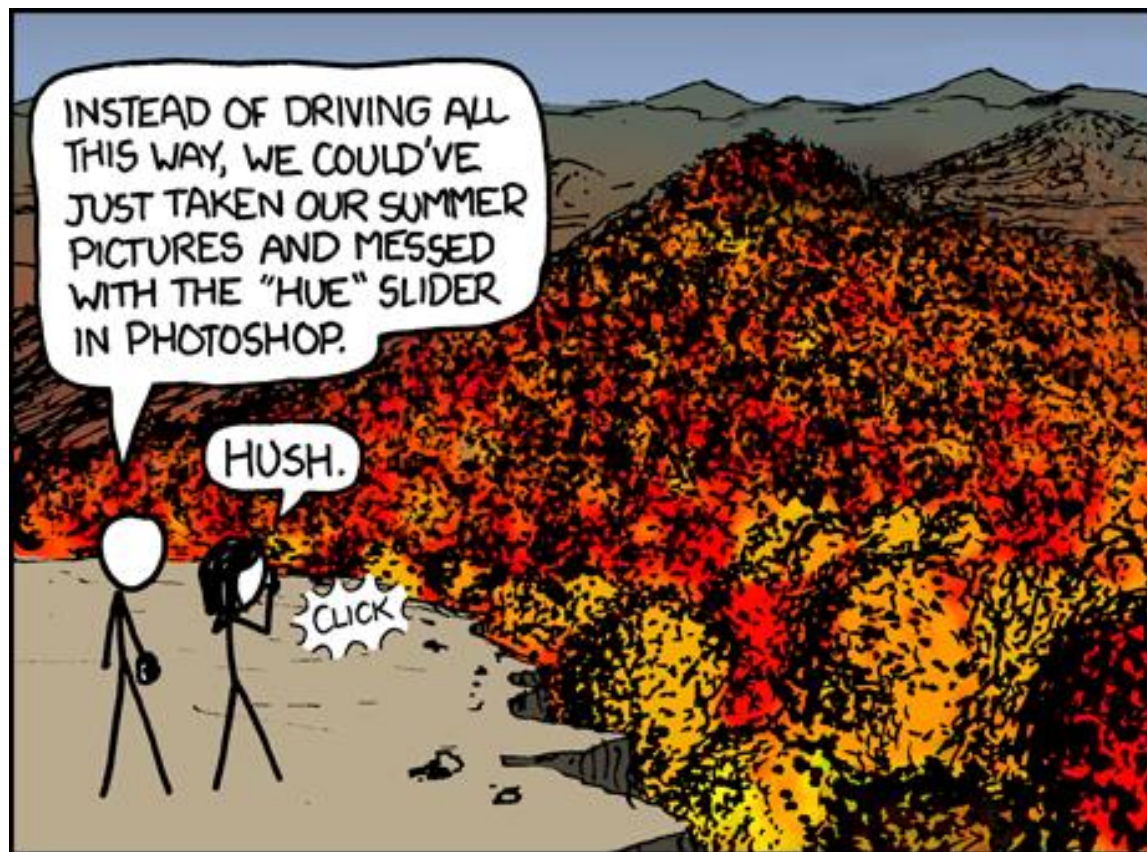

<https://xkcd.com/648/>

# Administrivia

- ❖ Lab 4 – Due Tonight! (3/02)
  - Cache parameter puzzles and code optimizations
- ❖ hw19 due Wednesday (3/04)
- ❖ hw20 due Friday (3/06)

# Address Translation: Page Hit

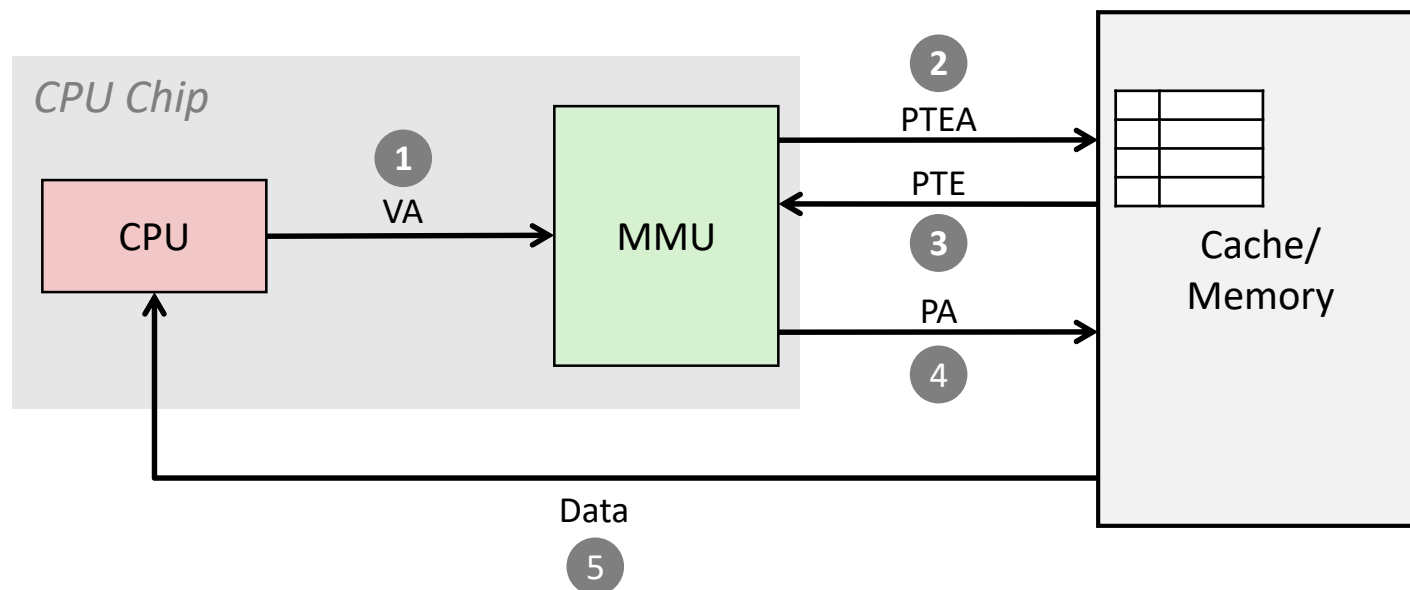

- 1) Processor sends *virtual* address to MMU (*memory management unit*)
- 2-3) MMU fetches PTE from page table in cache/memory  
(Uses PTBR to find beginning of page table for current process)
- 4) MMU sends *physical* address to cache/memory requesting data
- 5) Cache/memory sends data to processor

VA = Virtual Address      PTEA = Page Table Entry Address      PTE = Page Table Entry  
 PA = Physical Address      Data = Contents of memory stored at VA originally requested by CPU

# Address Translation: Page Fault

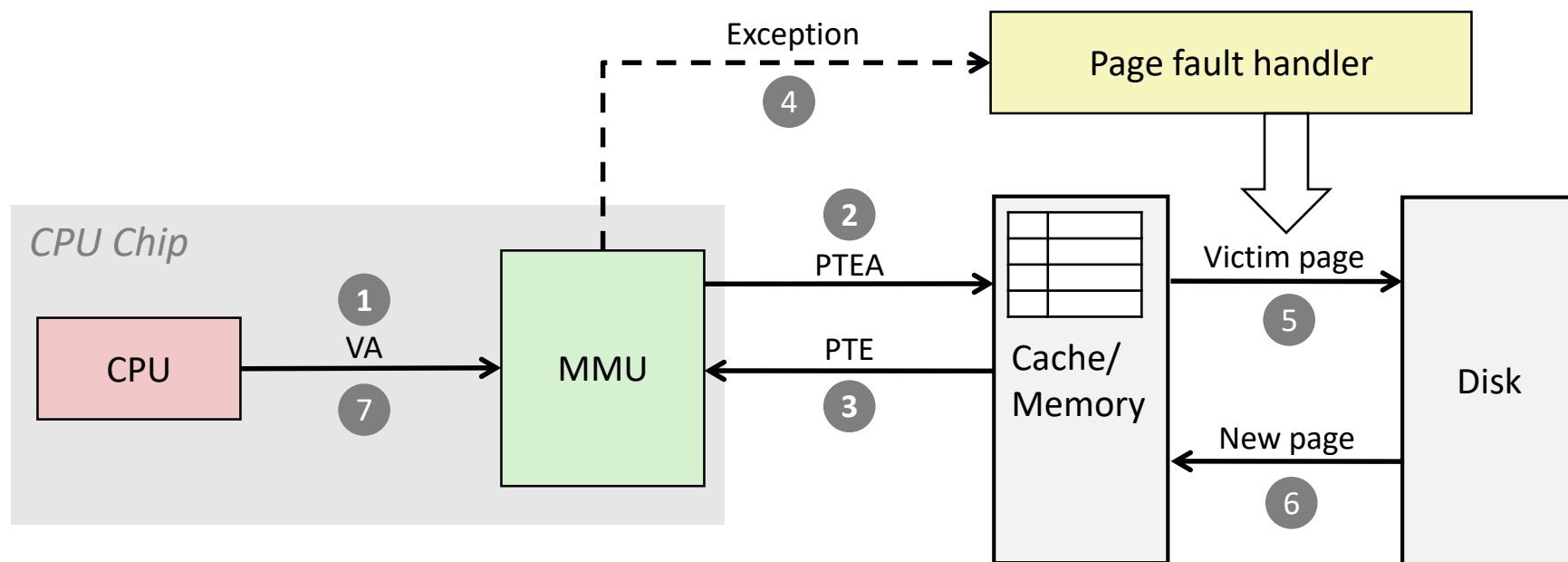

- 1) Processor sends virtual address to MMU
- 2-3) MMU fetches PTE from page table in cache/memory
- 4) Valid bit is zero, so MMU triggers page fault exception
- 5) Handler identifies victim (and, if dirty, pages it out to disk)
- 6) Handler pages in new page and updates PTE in memory
- 7) Handler returns to original process, restarting faulting instruction

# Hmm... Translation Sounds Slow

- ❖ The MMU accesses memory *twice*: once to get the PTE for translation, and then again for the actual memory request
  - The PTEs *may* be cached in L1 like any other memory word
    - But they may be evicted by other data references
    - And a hit in the L1 cache still requires 1-3 cycles
- ❖ *What can we do to make this faster?*
  - **Solution:** add another cache! 

# Speeding up Translation with a TLB

- ❖ *Translation Lookaside Buffer (TLB)*:
  - Small hardware cache in MMU
    - Split VPN into **TLB Tag** and **TLB Index** based on # of sets in TLB
  - Maps virtual page numbers to physical page numbers
  - Stores *page table entries* for a small number of pages
    - Modern Intel processors have 128 or 256 entries in TLB
  - Much faster than a page table lookup in cache/memory

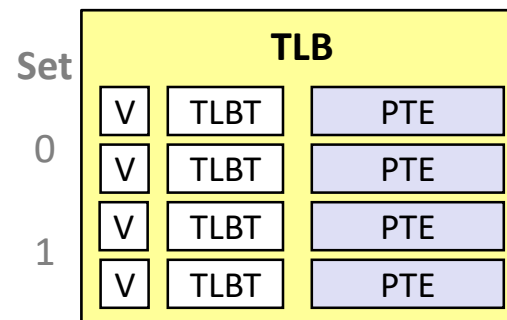
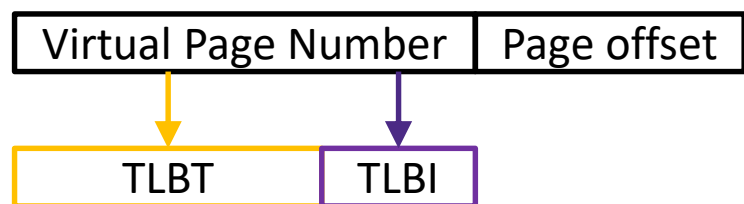

# TLB Hit

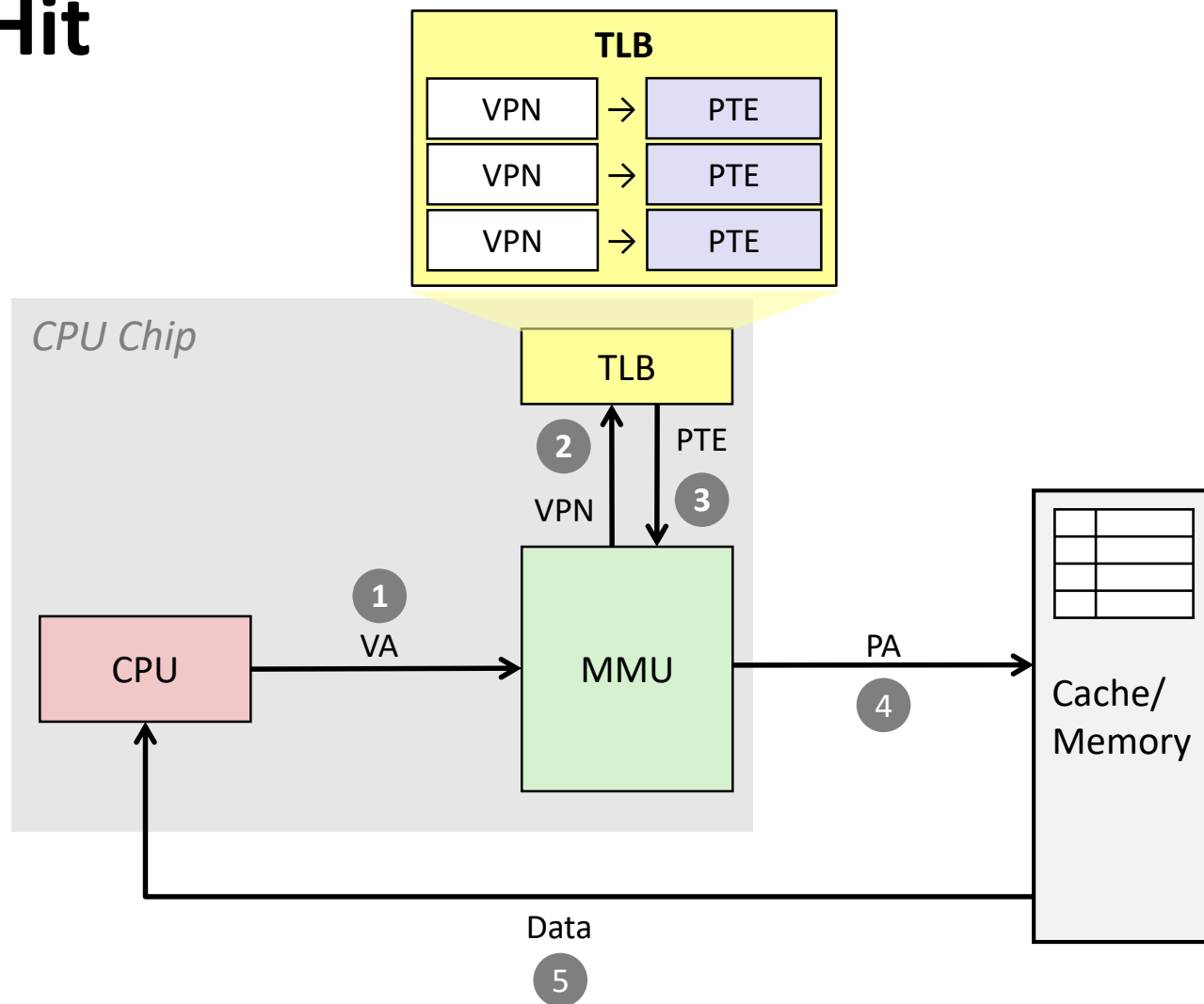

❖ A TLB hit eliminates a memory access!

# TLB Miss

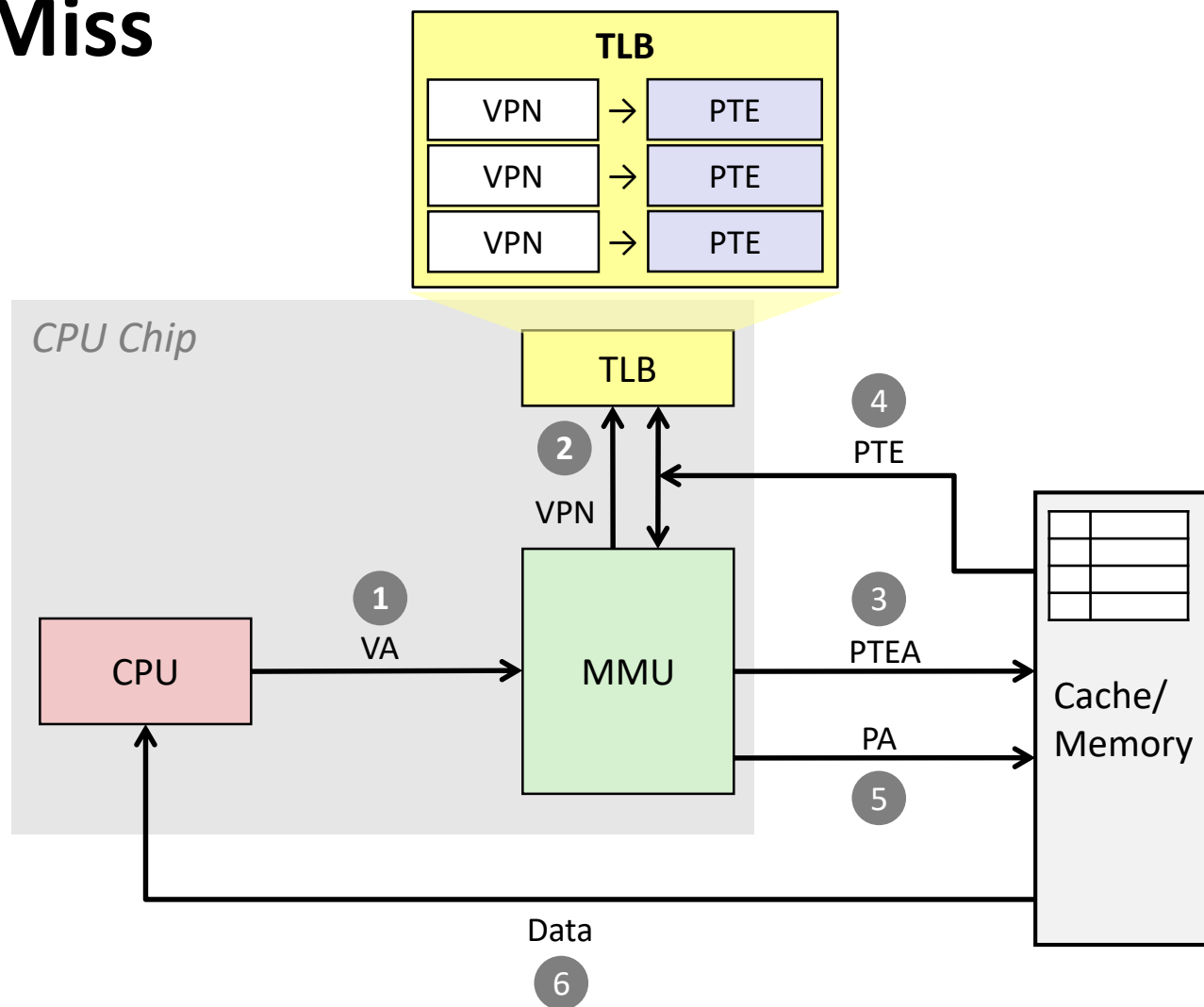

- ❖ A TLB miss incurs an additional memory access (the PTE)
  - Fortunately, TLB misses are rare



# Fetching Data on a Memory Read

## 1) Check TLB

- Input: VPN, Output: PPN
- *TLB Hit*: Fetch translation, return PPN
- *TLB Miss*: Check page table (in memory)
  - *Page Table Hit*: Load page table entry into TLB
  - *Page Fault*: Fetch page from disk to memory, update corresponding page table entry, then load entry into TLB

## 2) Check cache

- Input: physical address, Output: data
- *Cache Hit*: Return data value to processor
- *Cache Miss*: Fetch data value from memory, store it in cache, return it to processor

# Address Translation

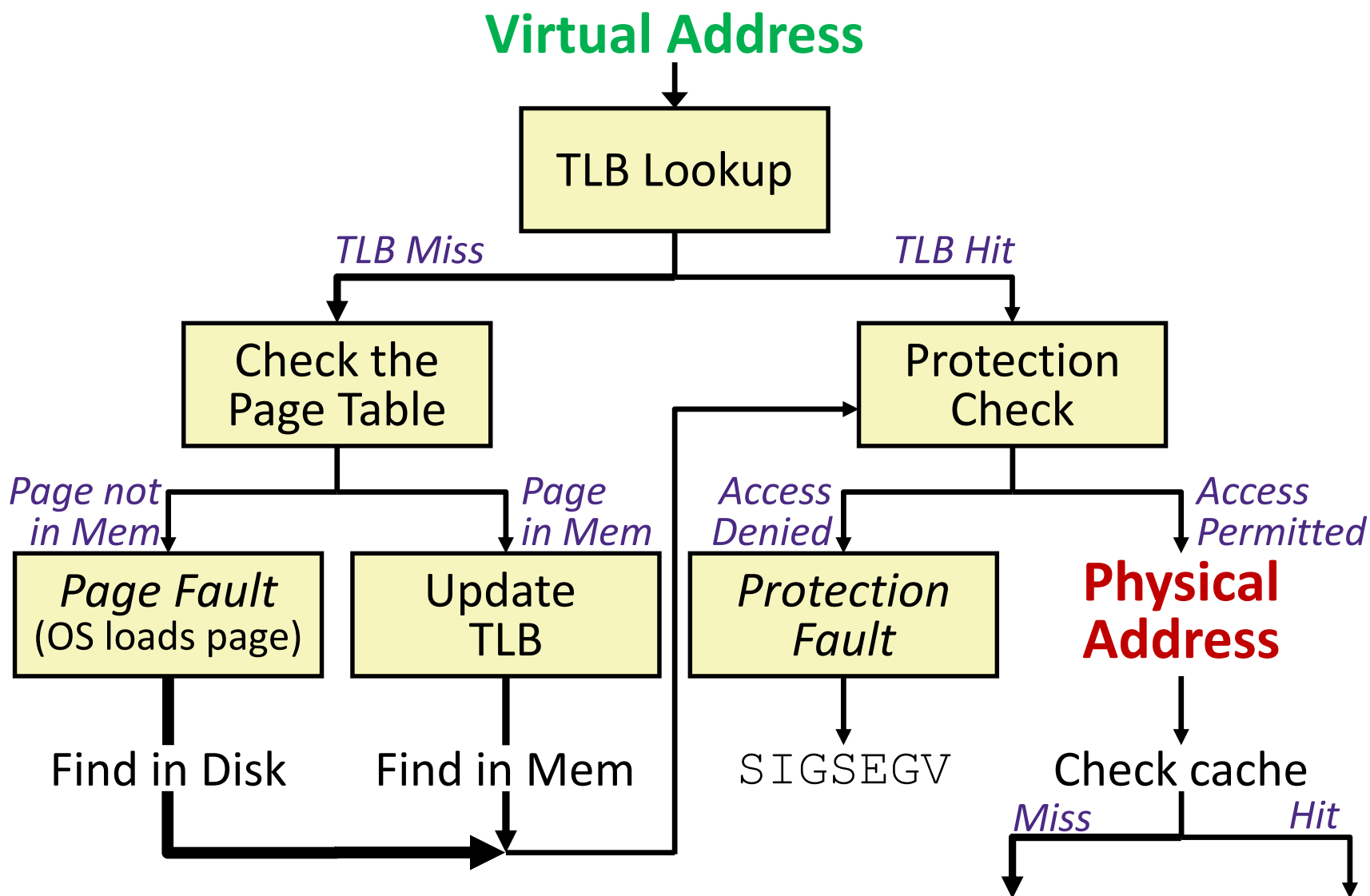

# Address Manipulation

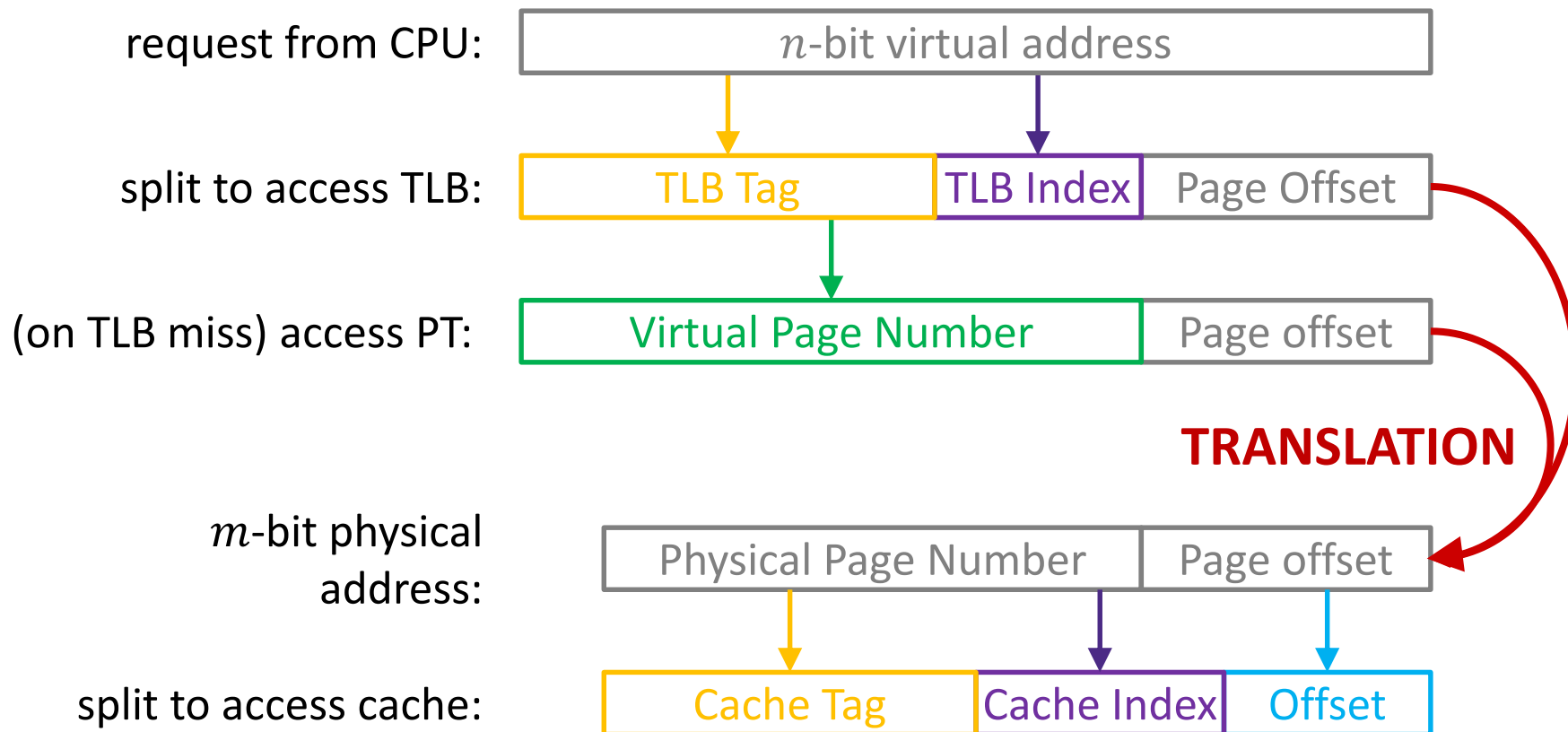

# Context Switching Revisited

- ❖ What needs to happen when the CPU switches processes?
  - Registers:
    - Save state of old process, load state of new process
    - Including the Page Table Base Register (PTBR)
  - Memory:
    - Nothing to do! Pages for processes already exist in memory/disk and protected from each other
  - TLB:
    - *invalidate* all entries in TLB – mapping is for old process' VAs
  - Cache:
    - Can leave alone because storing based on PAs – good for shared data

# Summary of Address Translation Symbols

## ❖ Basic Parameters

- $N = 2^n$  Number of addresses in virtual address space
- $M = 2^m$  Number of addresses in physical address space
- $P = 2^p$  Page size (bytes)

## ❖ Components of the virtual address (VA)

- **VPO** Virtual page offset
- **VPN** Virtual page number
- **TLBI** TLB index
- **TLBT** TLB tag

## ❖ Components of the physical address (PA)

- **PPO** Physical page offset (same as VPO)
- **PPN** Physical page number

# Simple Memory System Example (small)

## ❖ Addressing

- 14-bit virtual addresses
- 12-bit physical address
- Page size = 64 bytes

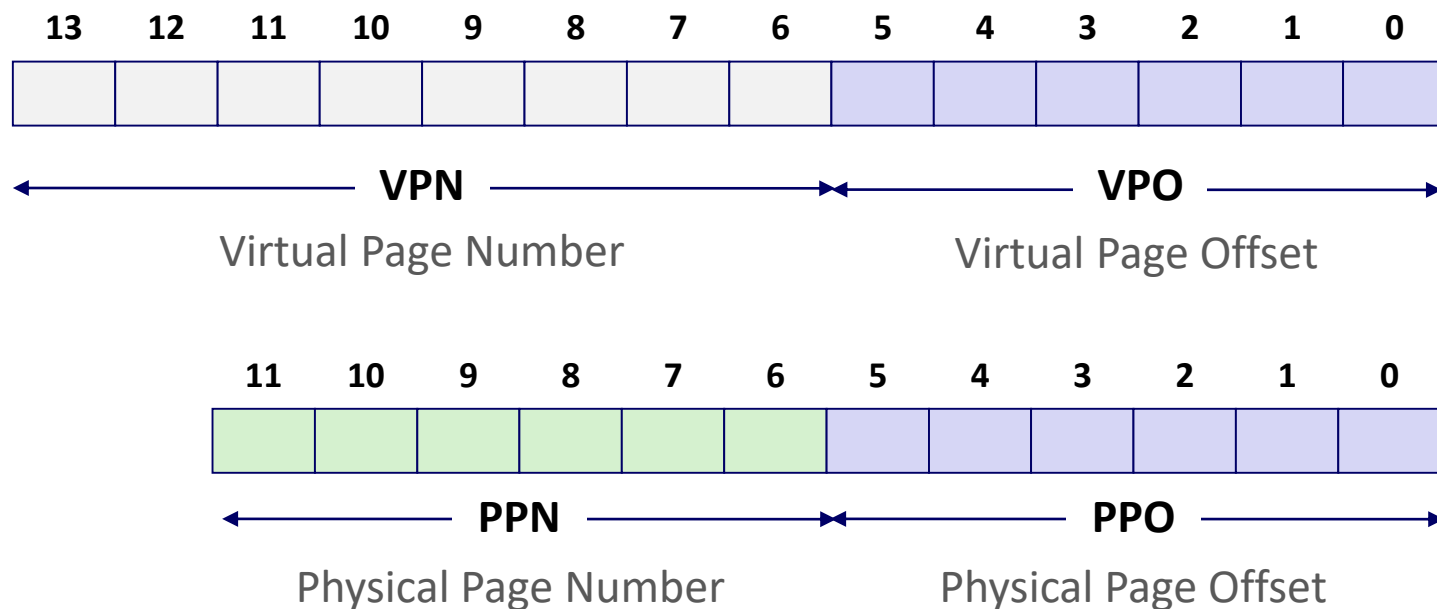

# Simple Memory System: Page Table

- ❖ Only showing first 16 entries (out of \_\_\_\_\_)
  - **Note:** showing 2 hex digits for PPN even though only 6 bits
  - **Note:** other management bits not shown, but part of PTE

<i>VPN</i>	<i>PPN</i>	<i>Valid</i>
0	28	1
1	–	0
2	33	1
3	02	1
4	–	0
5	16	1
6	–	0
7	–	0

<i>VPN</i>	<i>PPN</i>	<i>Valid</i>
8	13	1
9	17	1
A	09	1
B	–	0
C	–	0
D	2D	1
E	–	0
F	0D	1

# Simple Memory System: TLB

- ❖ 16 entries total
- ❖ 4-way set associative

Why does the TLB ignore the page offset?

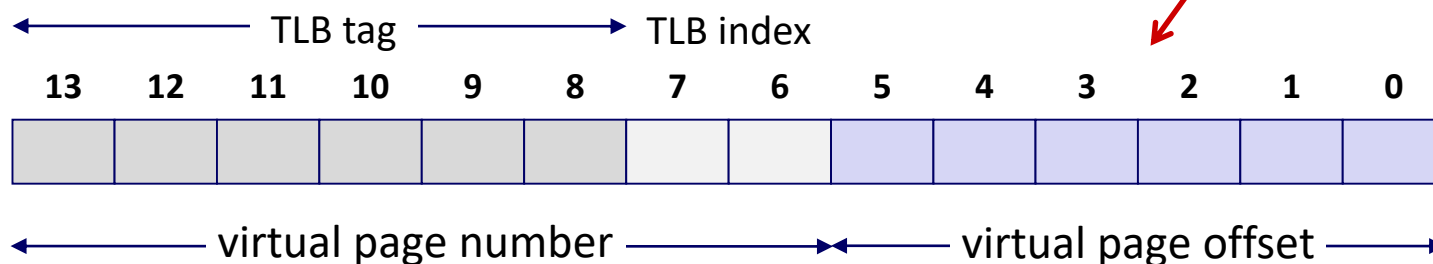

Set	Tag	PPN	Valid	Tag	PPN	Valid	Tag	PPN	Valid	Tag	PPN	Valid
0	03	–	0	09	0D	1	00	–	0	07	02	1
1	03	2D	1	02	–	0	04	–	0	0A	–	0
2	02	–	0	08	–	0	06	–	0	03	–	0
3	07	–	0	03	0D	1	0A	34	1	02	–	0



# Simple Memory System: Cache

**Note:** It is just coincidence that the PPN is the same width as the cache Tag

- ❖ Direct-mapped with  $K = 4 \text{ B}$ ,  $C/K = 16$
- ❖ Physically addressed

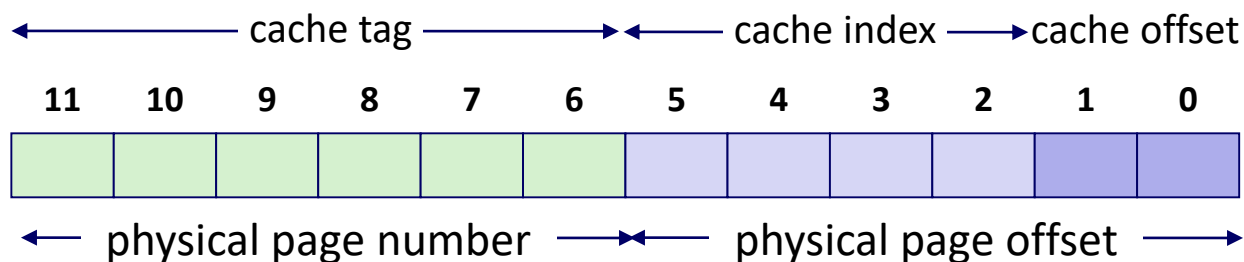

Index	Tag	Valid	B0	B1	B2	B3
0	19	1	99	11	23	11
1	15	0	–	–	–	–
2	1B	1	00	02	04	08
3	36	0	–	–	–	–
4	32	1	43	6D	8F	09
5	0D	1	36	72	F0	1D
6	31	0	–	–	–	–
7	16	1	11	C2	DF	03

Index	Tag	Valid	B0	B1	B2	B3
8	24	1	3A	00	51	89
9	2D	0	–	–	–	–
A	2D	1	93	15	DA	3B
B	0B	0	–	–	–	–
C	12	0	–	–	–	–
D	16	1	04	96	34	15
E	13	1	83	77	1B	D3
F	14	0	–	–	–	–

# Current State of Memory System

## TLB:

Set	Tag	PPN	V	Tag	PPN	V	Tag	PPN	V	Tag	PPN	V
0	03	-	0	09	0D	1	00	-	0	07	02	1
1	03	2D	1	02	-	0	04	-	0	0A	-	0
2	02	-	0	08	-	0	06	-	0	03	-	0
3	07	-	0	03	0D	1	0A	34	1	02	-	0

## Page table (partial):

VPN	PPN	V	VPN	PPN	V
0	28	1	8	13	1
1	-	0	9	17	1
2	33	1	A	09	1
3	02	1	B	-	0
4	-	0	C	-	0
5	16	1	D	2D	1
6	-	0	E	-	0
7	-	0	F	0D	1

## Cache:

Index	Tag	V	B0	B1	B2	B3
0	19	1	99	11	23	11
1	15	0	-	-	-	-
2	1B	1	00	02	04	08
3	36	0	-	-	-	-
4	32	1	43	6D	8F	09
5	0D	1	36	72	F0	1D
6	31	0	-	-	-	-
7	16	1	11	C2	DF	03

Index	Tag	V	B0	B1	B2	B3
8	24	1	3A	00	51	89
9	2D	0	-	-	-	-
A	2D	1	93	15	DA	3B
B	0B	0	-	-	-	-
C	12	0	-	-	-	-
D	16	1	04	96	34	15
E	13	1	83	77	1B	D3
F	14	0	-	-	-	-

# Memory Request Example #1

**Note:** It is just coincidence that the PPN is the same width as the cache Tag

❖ Virtual Address: 0x03D4

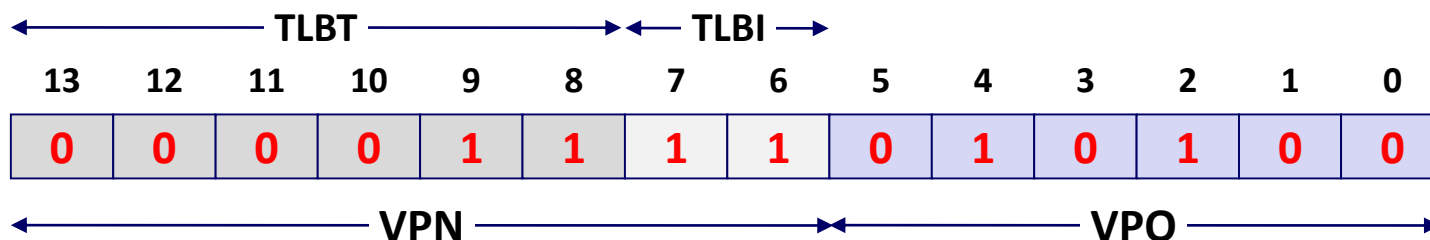

VPN \_\_\_\_\_ TLBT \_\_\_\_\_ TLBI \_\_\_\_\_ TLB Hit? \_\_\_\_ Page Fault? \_\_\_\_ PPN \_\_\_\_\_

❖ Physical Address:

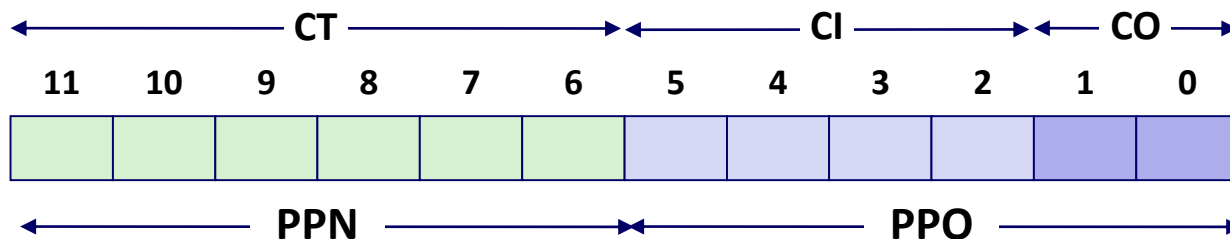

CT \_\_\_\_\_ CI \_\_\_\_\_ CO \_\_\_\_\_ Cache Hit? \_\_\_\_ Data (byte) \_\_\_\_\_

# Memory Request Example #2

**Note:** It is just coincidence that the PPN is the same width as the cache Tag

❖ Virtual Address: 0x038F

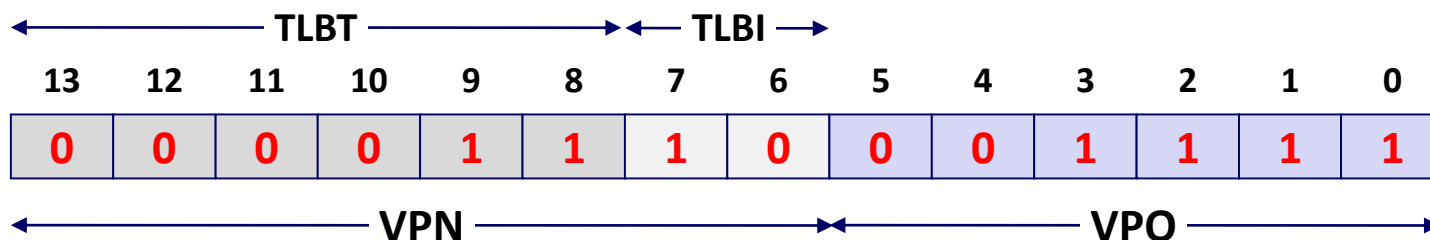

VPN \_\_\_\_\_ TLBT \_\_\_\_\_ TLBI \_\_\_\_\_ TLB Hit? \_\_\_\_ Page Fault? \_\_\_\_ PPN \_\_\_\_\_

❖ Physical Address:

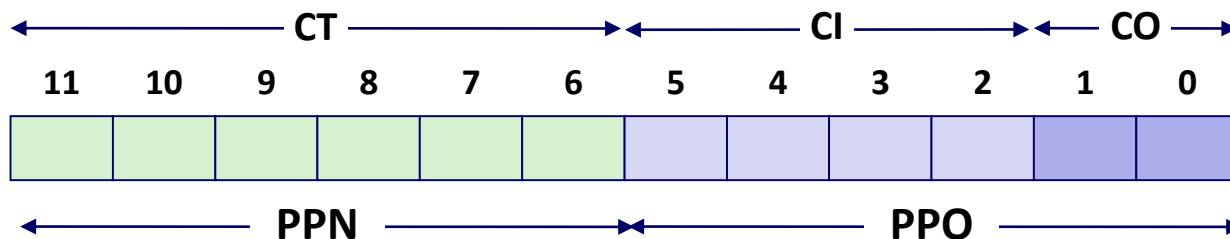

CT \_\_\_\_\_ CI \_\_\_\_\_ CO \_\_\_\_\_ Cache Hit? \_\_\_\_ Data (byte) \_\_\_\_\_

# Memory Request Example #3

**Note:** It is just coincidence that the PPN is the same width as the cache Tag

❖ Virtual Address: 0x0020

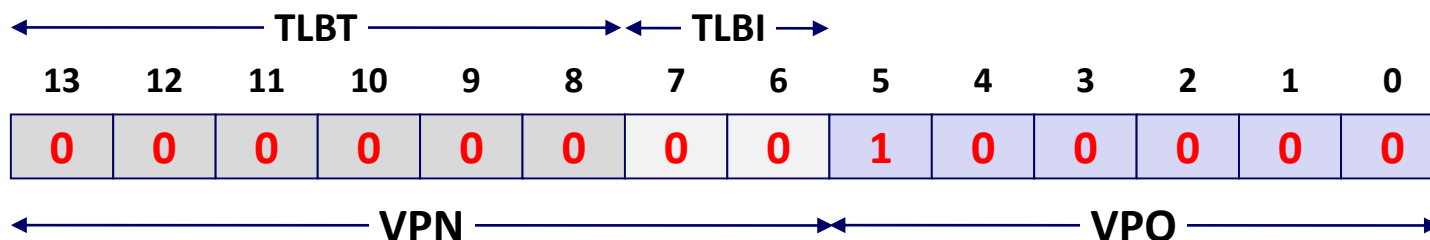

VPN \_\_\_\_\_ TLBT \_\_\_\_\_ TLBI \_\_\_\_\_ TLB Hit? \_\_\_\_ Page Fault? \_\_\_\_ PPN \_\_\_\_\_

❖ Physical Address:

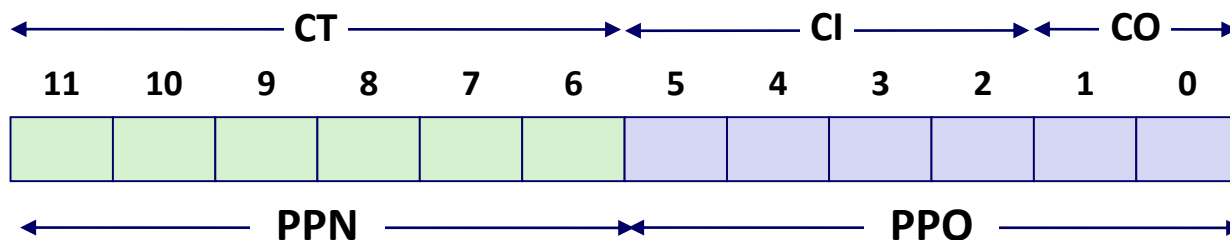

CT \_\_\_\_\_ CI \_\_\_\_\_ CO \_\_\_\_\_ Cache Hit? \_\_\_\_ Data (byte) \_\_\_\_\_

# Memory Request Example #4

**Note:** It is just coincidence that the PPN is the same width as the cache Tag

❖ Virtual Address: 0x036B

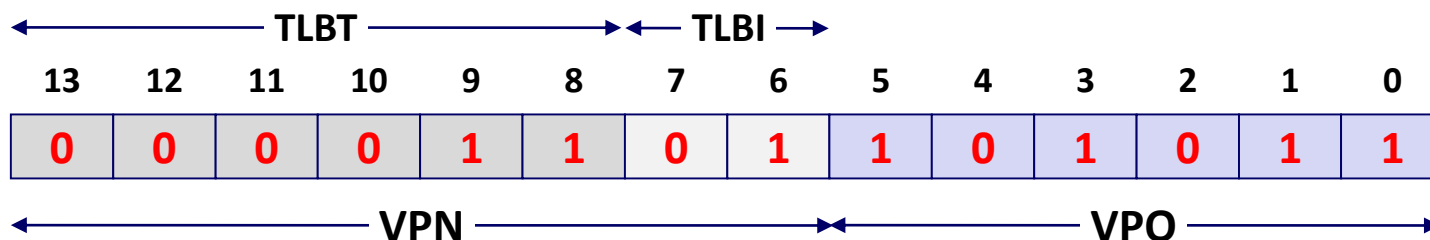

VPN \_\_\_\_\_ TLBT \_\_\_\_\_ TLBI \_\_\_\_\_ TLB Hit? \_\_\_\_ Page Fault? \_\_\_\_ PPN \_\_\_\_\_

❖ Physical Address:

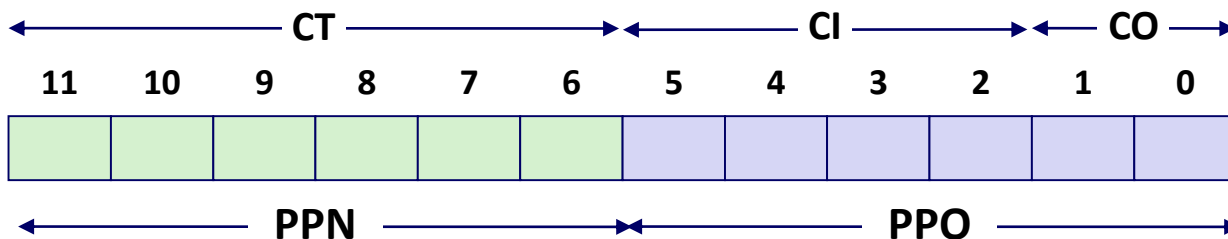

CT \_\_\_\_\_ CI \_\_\_\_\_ CO \_\_\_\_\_ Cache Hit? \_\_\_\_ Data (byte) \_\_\_\_\_

# Memory Overview

```
❖ movl 0x8043ab, %rdi
```

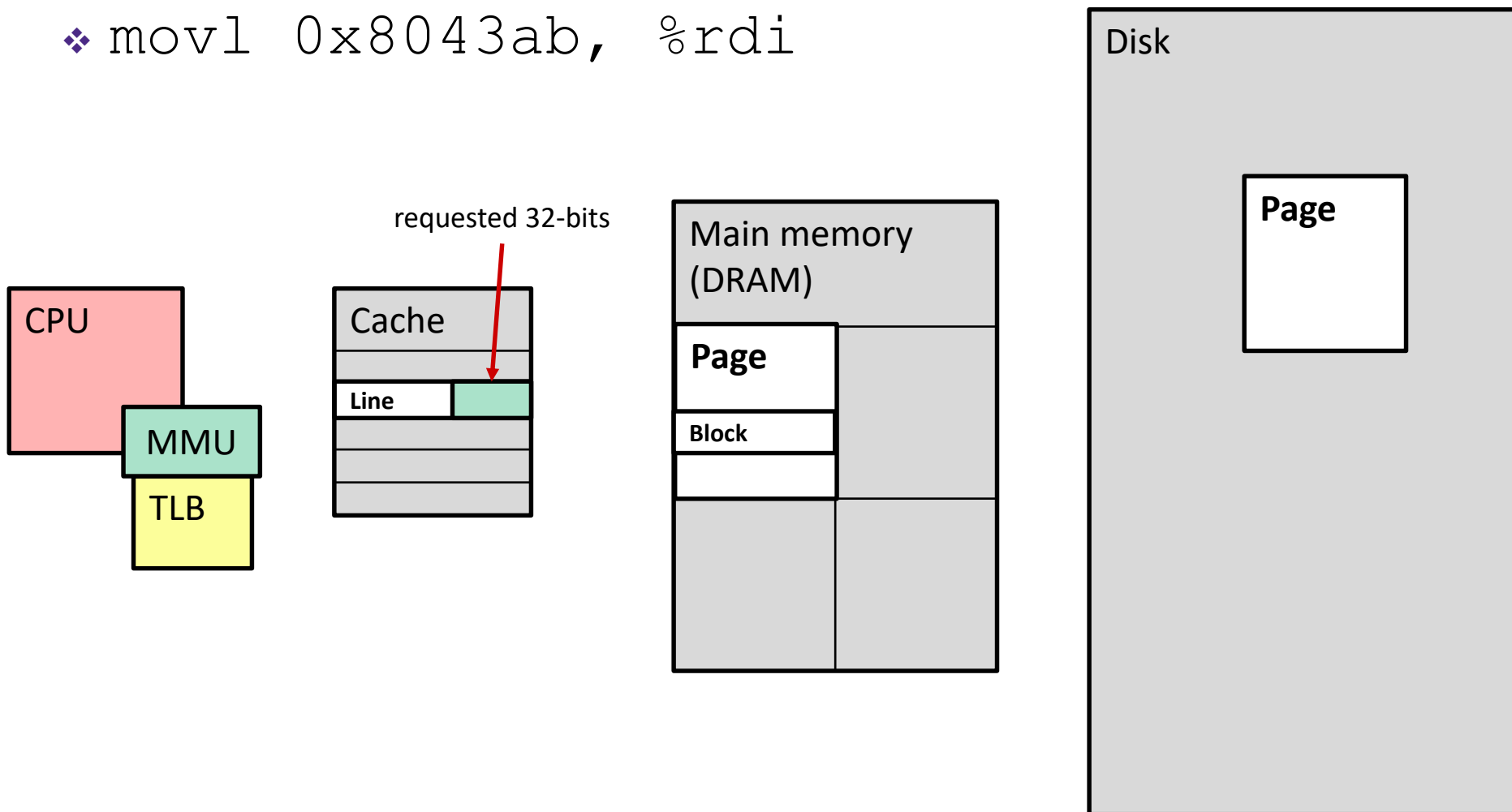

# Page Table Reality

This is extra  
(non-testable)  
material

- ❖ Just one issue... the numbers don't work out for the story so far!
- ❖ The problem is the page table for each process:
  - Suppose 64-bit VAs, 8 KiB pages, 8 GiB physical memory
  - How many page table entries is that?
  - About how long is each PTE?
  - **Moral:** Cannot use this naïve implementation of the virtual→physical page mapping – it's *way* too big



# A Solution: Multi-level Page Tables

This is extra (non-testable) material

This is called a *page walk*

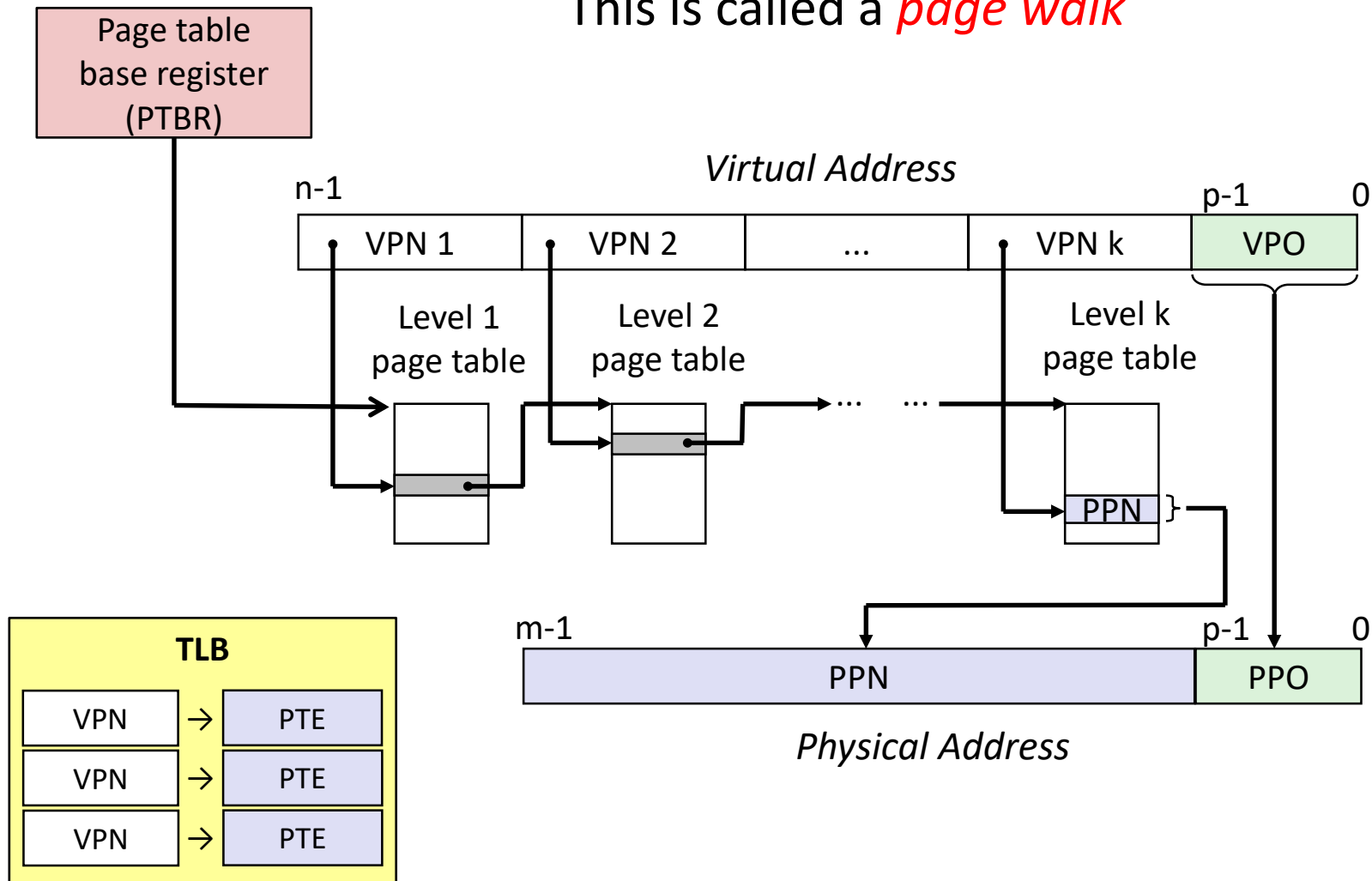

# Multi-level Page Tables

This is extra  
(non-testable)  
material

- ❖ A tree of depth  $k$  where each node at depth  $i$  has up to  $2^j$  children if part  $i$  of the VPN has  $j$  bits
- ❖ Hardware for multi-level page tables inherently more complicated
  - But it's a necessary complexity – 1-level does not fit
- ❖ Why it works: Most subtrees are not used at all, so they are never created and definitely aren't in physical memory
  - Parts created can be evicted from cache/memory when not being used
  - Each node can have a size of  $\sim 1\text{-}100\text{KB}$
- ❖ But now for a  $k$ -level page table, a TLB miss requires  $k + 1$  cache/memory accesses
  - Fine so long as TLB misses are rare – motivates larger TLBs

# Practice VM Question

- ❖ Our system has the following properties
  - 1 MiB of physical address space
  - 4 GiB of virtual address space
  - 32 KiB page size
  - 4-entry fully associative TLB with LRU replacement

a) Fill in the following blanks:

\_\_\_\_\_ Entries in a page table

\_\_\_\_\_ Minimum bit-width of  
PTBR

\_\_\_\_\_ TLBT bits

\_\_\_\_\_ Max # of valid entries  
in a page table

# Practice VM Question

- ❖ One process uses a page-aligned *square* matrix `mat [ ]` of 32-bit integers in the code shown below:

```
#define MAT_SIZE = 2048
for(int i = 0; i < MAT_SIZE; i++)
    mat[i*(MAT_SIZE+1)] = i;
```

- b) What is the largest stride (in bytes) between successive memory accesses (in the VA space)?

# Practice VM Question

- ❖ One process uses a page-aligned *square* matrix `mat[]` of 32-bit integers in the code shown below:

```
#define MAT_SIZE = 2048
for(int i = 0; i < MAT_SIZE; i++)
    mat[i*(MAT_SIZE+1)] = i;
```

- c) Assuming all of `mat[]` starts on disk, what are the following hit rates for the execution of the for-loop?

\_\_\_\_\_ TLB Hit Rate

\_\_\_\_\_ Page Table Hit Rate

# Virtual Memory Summary

- ❖ Programmer's view of virtual memory
  - Each process has its own private linear address space
  - Cannot be corrupted by other processes
  
- ❖ System view of virtual memory
  - Uses memory efficiently by caching virtual memory pages
    - Efficient only because of locality
  - Simplifies memory management and sharing
  - Simplifies protection by providing permissions checking

# Memory System Summary

- ❖ Memory Caches (L1/L2/L3)
  - Purely a speed-up technique
  - Behavior invisible to application programmer and (mostly) OS
  - Implemented totally in hardware
- ❖ Virtual Memory
  - Supports many OS-related functions
    - Process creation, task switching, protection
  - Operating System (software)
    - Allocates/shares physical memory among processes
    - Maintains high-level tables tracking memory type, source, sharing
    - Handles exceptions, fills in hardware-defined mapping tables
  - Hardware
    - Translates virtual addresses via mapping tables, enforcing permissions
    - Accelerates mapping via translation cache (TLB)