

Caches III

CSE 351 Autumn 2019

Instructor:

Justin Hsia

Teaching Assistants:

Andrew Hu

Antonio Castelli

Cosmo Wang

Diya Joy

Ivy Yu

Kaelin Laundry

Maurice Montag

Melissa Birchfield

Millicent Li

Suraj Jagadeesh

Scrooge
McDuck

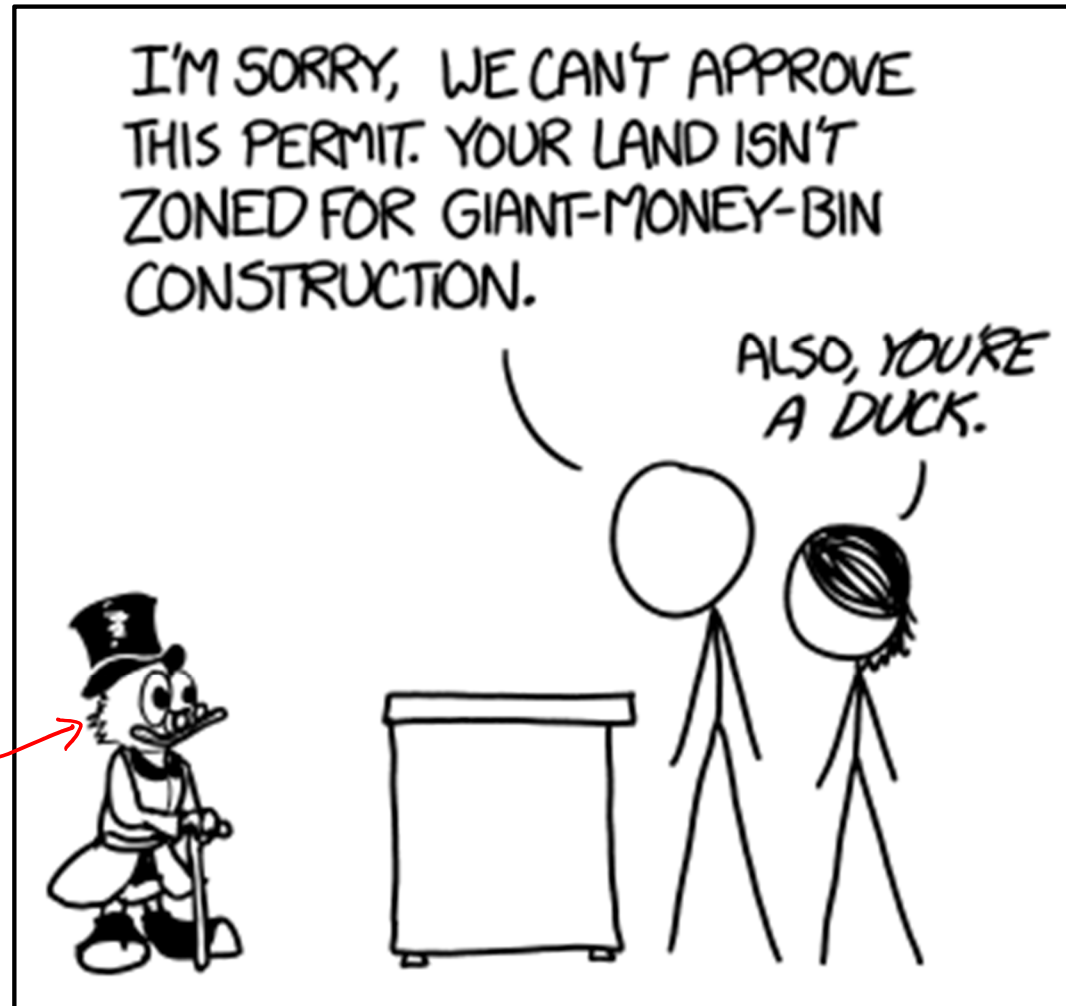

<https://what-if.xkcd.com/111/>

Administrivia

- ❖ Lab 3 due Friday
 - Late days count as normal: Sunday is 1 day, Monday is 2
- ❖ No lecture next Monday – Veteran's Day!
- ❖ hw17 due *next* Wednesday (11/13)
 - Covers the rest of caching

Making memory accesses fast!

- ❖ Cache basics
- ❖ Principle of locality
- ❖ Memory hierarchies
- ❖ Cache organization
 - Direct-mapped (*sets*; index + tag)
 - **Associativity (*ways*)**
 - **Replacement policy**
 - Handling writes
- ❖ Program optimizations that consider caches

Review: Direct-Mapped Cache

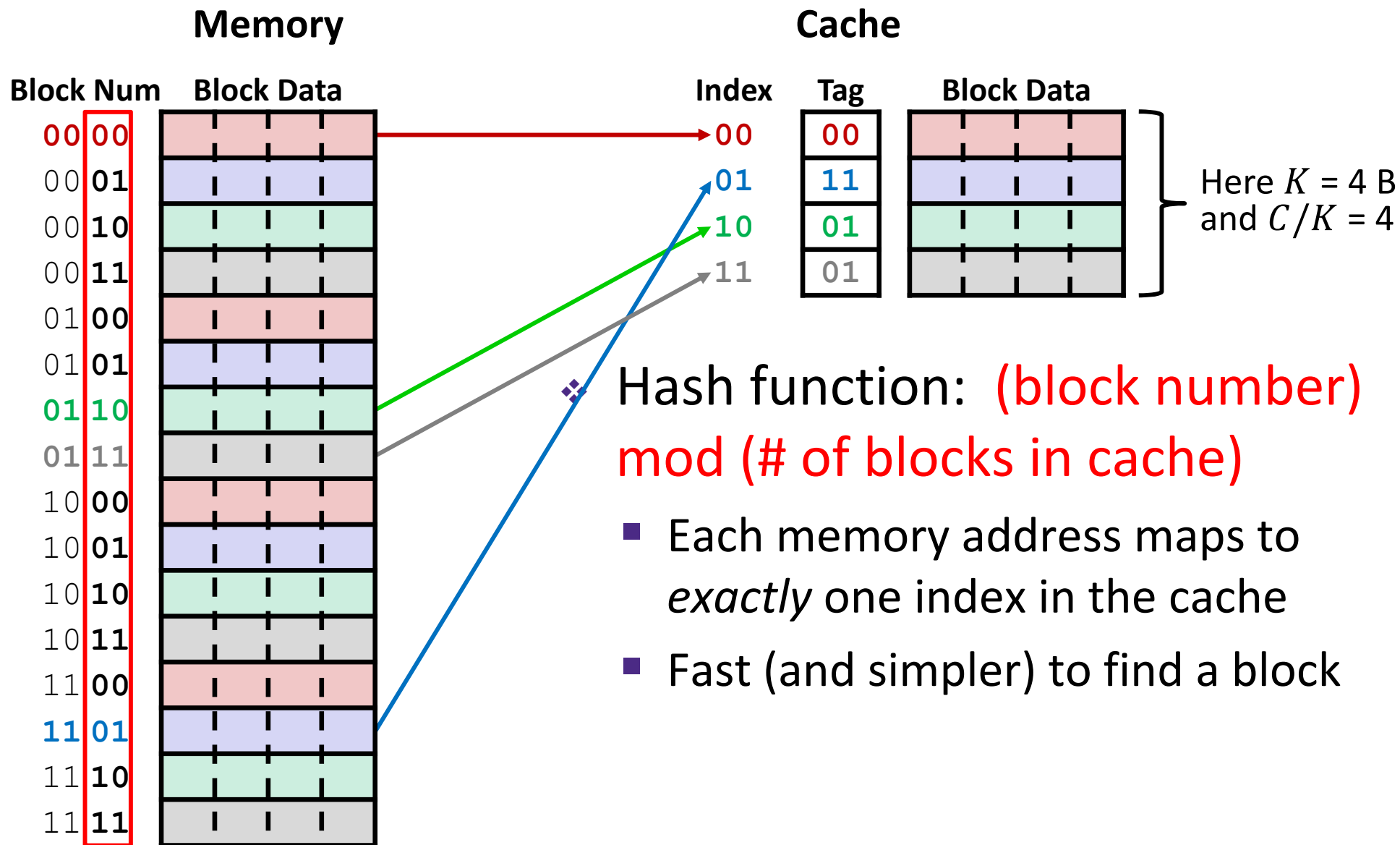

Direct-Mapped Cache Problem

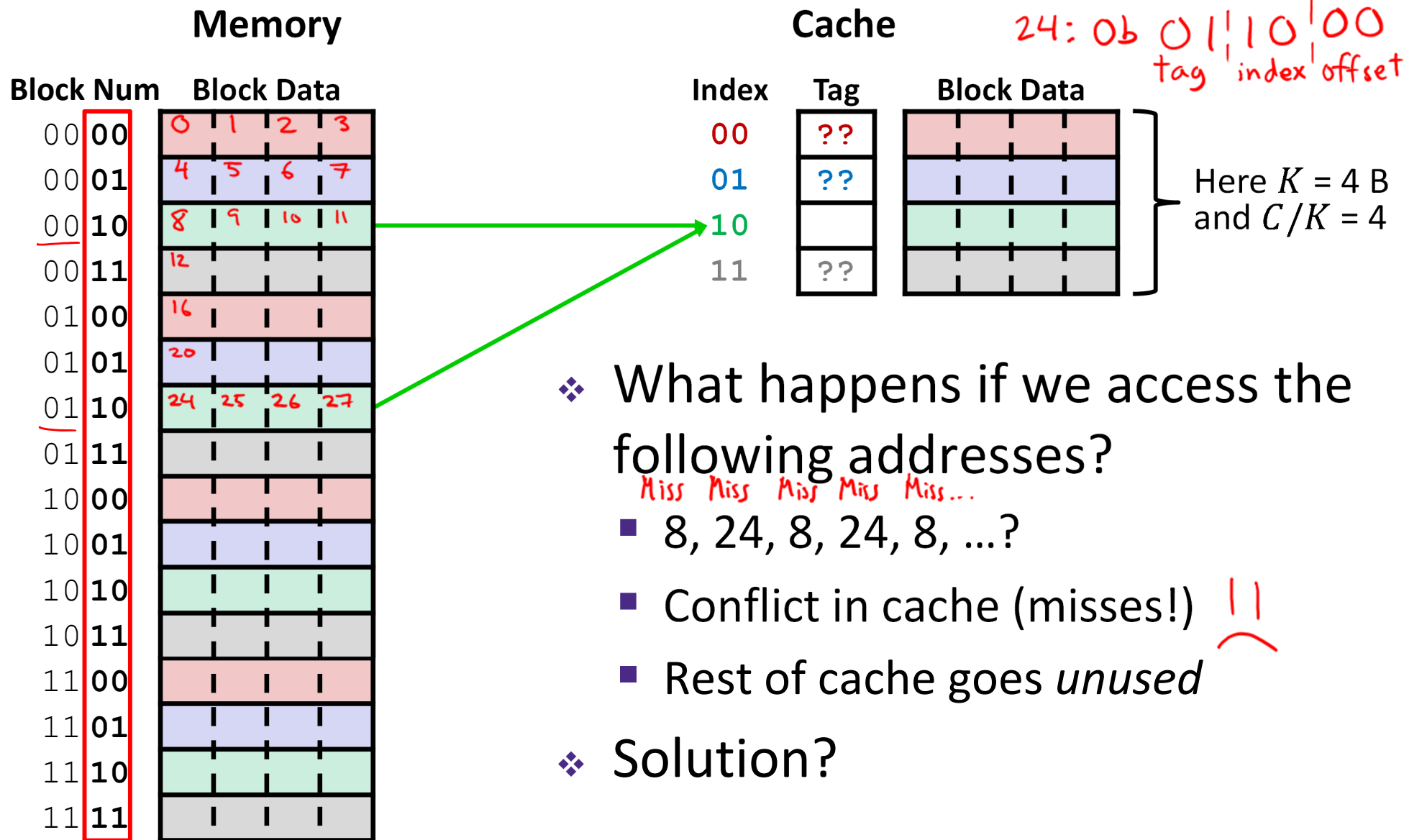

Associativity

- ❖ What if we could store data in any place in the cache?
 - More complicated hardware = more power consumed, slower
- ❖ So we *combine* the two ideas:
 - Each address maps to exactly one **set**
 - Each set can store block in more than one **way**

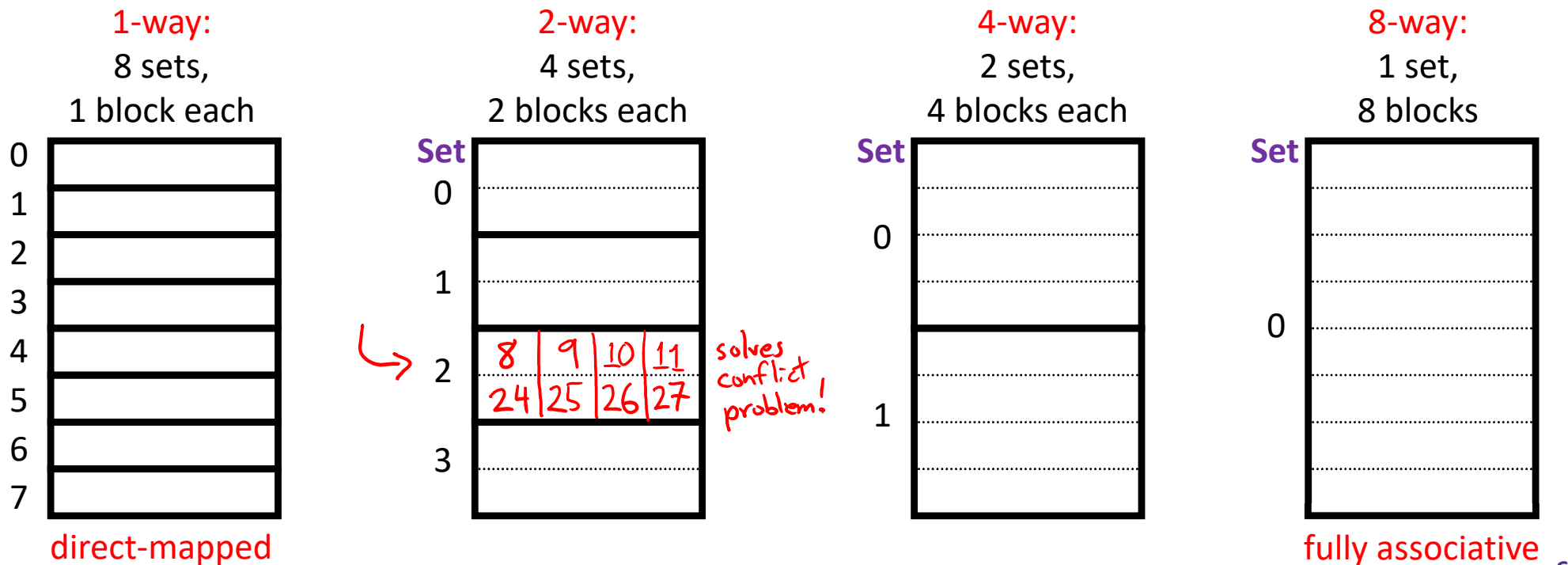

Cache Organization (3)

Note: The textbook uses “b” for offset bits

- ❖ **Associativity (E):** # of ways for each set
 - Such a cache is called an “ E -way set associative cache”
 - We now index into cache sets, of which there are $S = C/K/E$
 - Use lowest $\log_2(C/K/E) = s$ bits of block address
 - Direct-mapped: $E = 1$, so $s = \log_2(C/K)$ as we saw previously
 - Fully associative: $E = C/K$, so $s = 0$ bits

m bits total

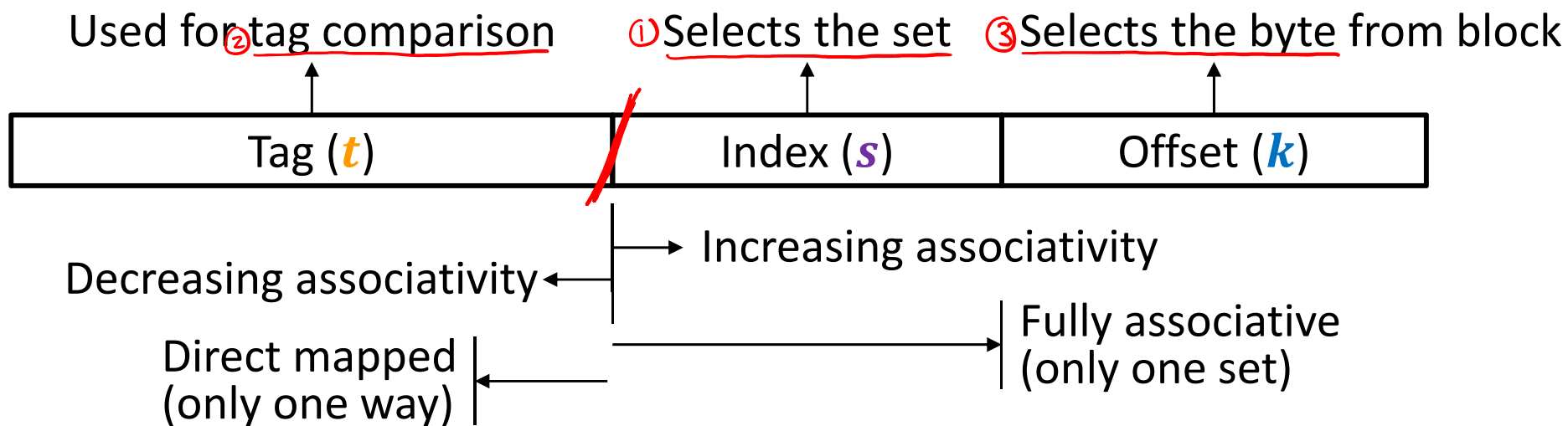

Example Placement

block size:	16 B
capacity:	8 blocks
address:	16 bits

❖ Where would data from address 0x1833 be placed?

■ Binary: 0b 0001 1000 0011 0011

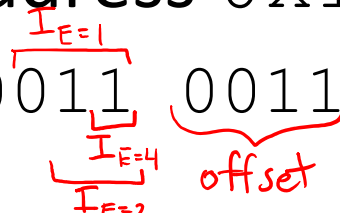

$$t = m - s - k \quad s = \log_2(C/K/E) \quad k = \log_2(K)$$

m-bit address:

Tag (<i>t</i>)	Index (<i>s</i>)	Offset (<i>k</i>)
------------------	--------------------	---------------------

s = ?

Direct-mapped

Set	Tag	Data
(000) 0		
(001) 1		
(010) 2		
(011) 3	✓	
(100) 4		
(101) 5		
(110) 6		
(111) 7		

s = ?

2-way set associative

Set	Tag	Data
(00)0		
(01)1		
(10)2		
(11)3	✓	✓

s = ?

4-way set associative

Set	Tag	Data
(0)0		
(1)1		✓
		✓
		✓
		✓

Block Replacement

- ❖ Any empty block in the correct set may be used to store block Valid = 0
- ❖ If there are no empty blocks, which one should we replace?
 - No choice for direct-mapped caches
 - Caches typically use something close to **least recently used (LRU)** (hardware usually implements “not most recently used”)

Direct-mapped

Set	Tag	Data
0		
1		
2		
3		
4		
5		
6		
7		

2-way set associative

Set	Tag	Data
0		
1		
2		
3		

4-way set associative

Set	Tag	Data
0		
1		
1		
1		
1		
1		

Valid bit

0
0
0
0

1
1
1
1

Polling Question

❖ We have a cache of size 2 KiB with block size of 128 B. If our cache has 2 sets, what is its associativity?

$K = 2^7 B$

$C = 2^{11} B$

cache holds $C/K = 2^{11-7} = 2^4 = 16$ blocks

▪ Vote at <http://PollEv.com/justinh>

A. 2

B. 4

C. 8

D. 16

E. We're lost...

each set has 8 blocks, so $E=8$

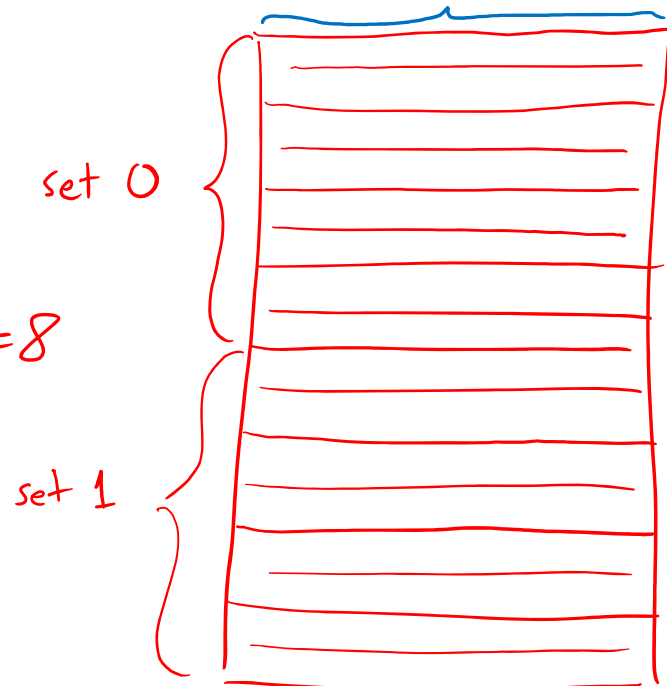

$S = C/K/E$

$E = (C/K)/S = 16/2 = 8$

cache size

$m=16$

❖ If addresses are 16 bits wide, how wide is the Tag field? $k = \log_2(K) = 7$ bits, $s = \log_2(S) = 1$ bit, $t = m - s - k = 8$ bits

General Cache Organization (S, E, K)

associativity
sets
block size

$E =$ blocks (or lines) per set

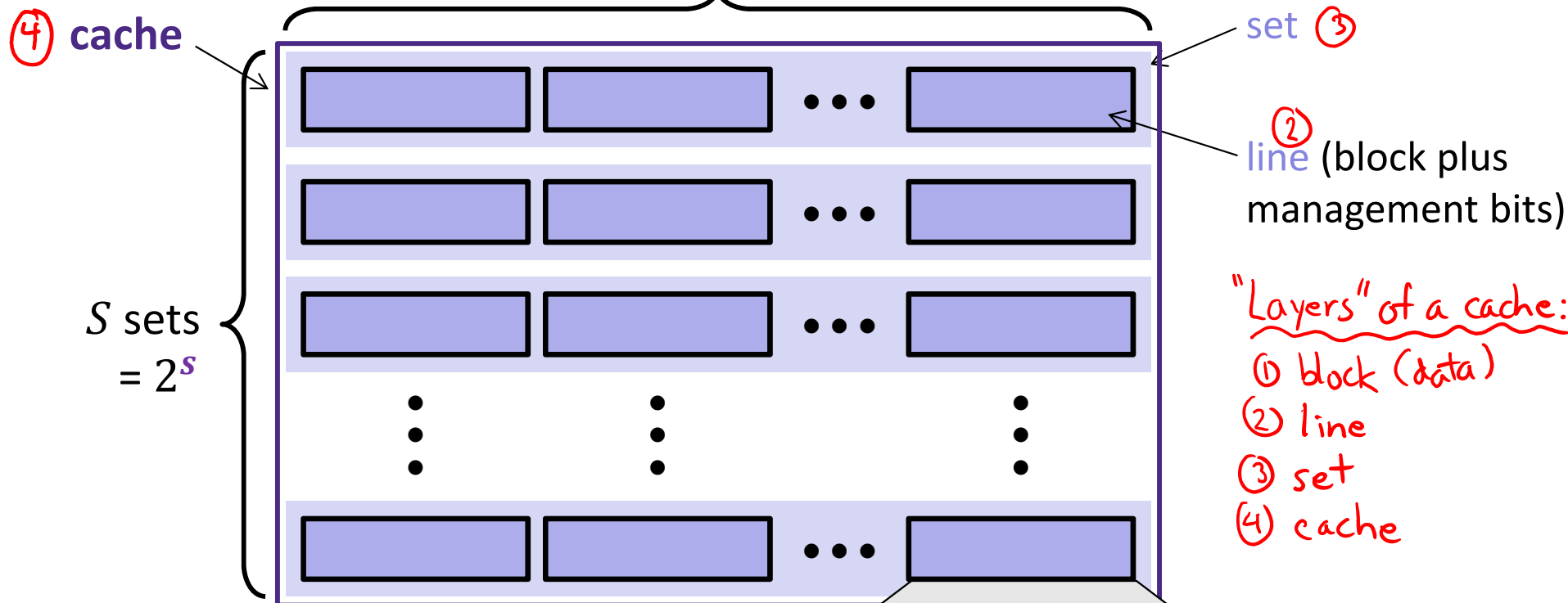

Cache size:

$C = K \times E \times S$ data bytes
(doesn't include V or Tag)

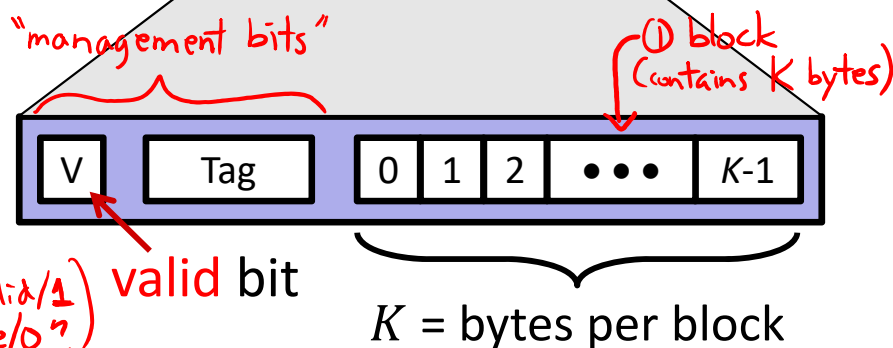

(is this data valid/1 or garbage/0?)

Notation Review

- ❖ We just introduced a lot of new variable names!
 - Please be mindful of block size notation when you look at past exam questions or are watching videos

Parameter	Variable	Formulas
Block size	K (B in book)	$M = 2^m \leftrightarrow m = \log_2 M$ $S = 2^s \leftrightarrow s = \log_2 S$ $K = 2^k \leftrightarrow k = \log_2 K$ $C = K \times E \times S$ $s = \log_2(C/K/E)$ $m = t + s + k$
Cache size	C	
Associativity	E	
Number of Sets	S	
Address space	M	
Address width	m	
Tag field width	t	
Index field width	s	
Offset field width	k (b in book)	

Example Cache Parameters Problem

$\rightarrow 2^{12} \text{ B} \iff m = 12 \text{ bits}$ MP

- ❖ 4 KiB address space, 125 cycles to go to memory.

Fill in the following table:

C	Cache Size	256 B	2^8
K	Block Size	32 B	2^5
E	Associativity	2-way	2^1
HT	Hit Time	3 cycles	
MR	Miss Rate	20%	
$t = m - s - k$	Tag Bits	5	
$s = \log_2(C/K/E)$	Index Bits	2	$2^8 / 2^5 / 2^1$
$k = \log_2(K)$	Offset Bits	5	
$AMAT = HT + MR * MP$	AMAT	$3 + 0.2(125) = 28$ clock cycles	

Cache Read

- 1) *Locate set*
- 2) *Check if any line in set is valid and has matching tag: hit*
- 3) *Locate data starting at offset*

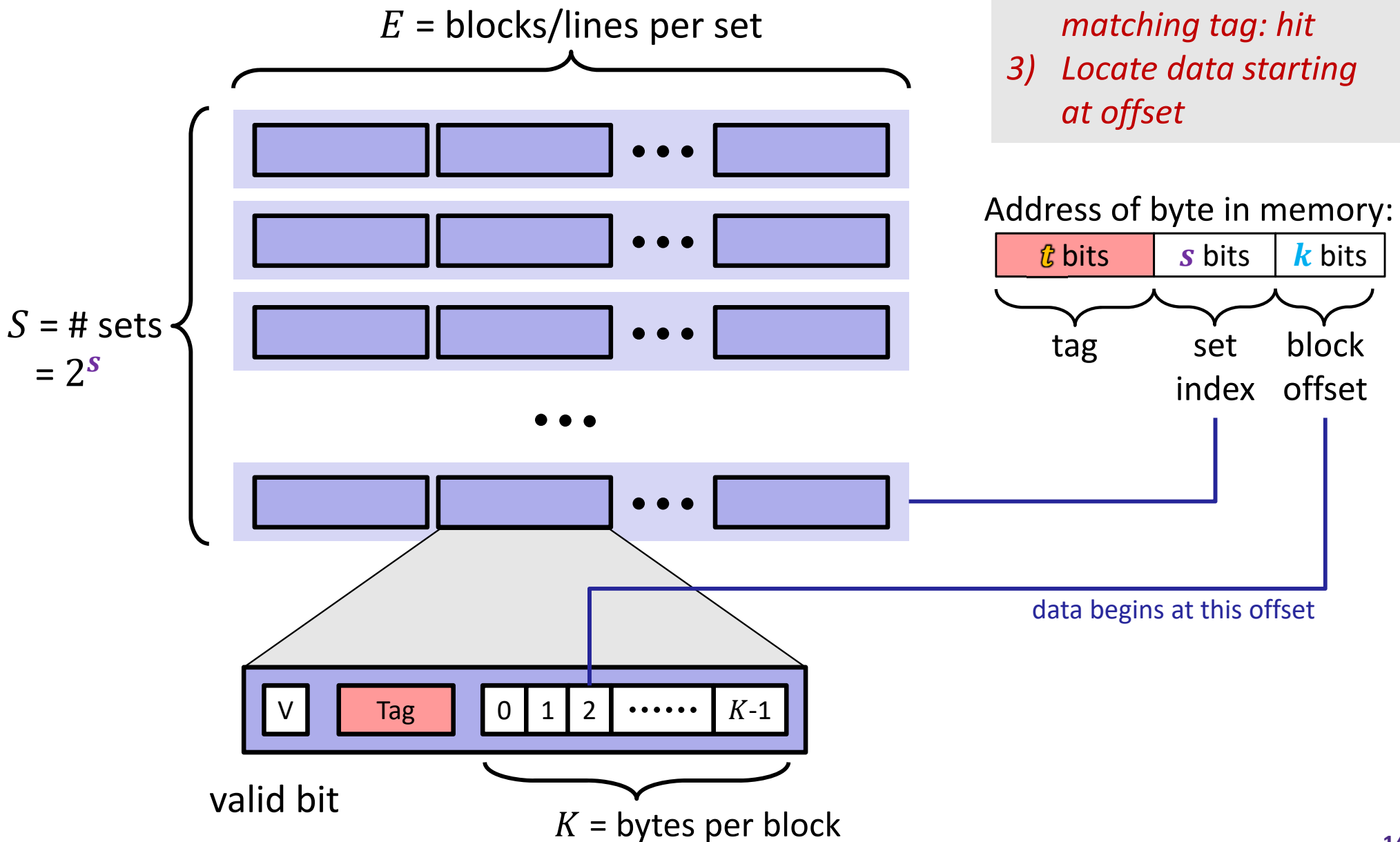

Example: Direct-Mapped Cache ($E = 1$)

Direct-mapped: One line per set

Block Size $K = 8$ B

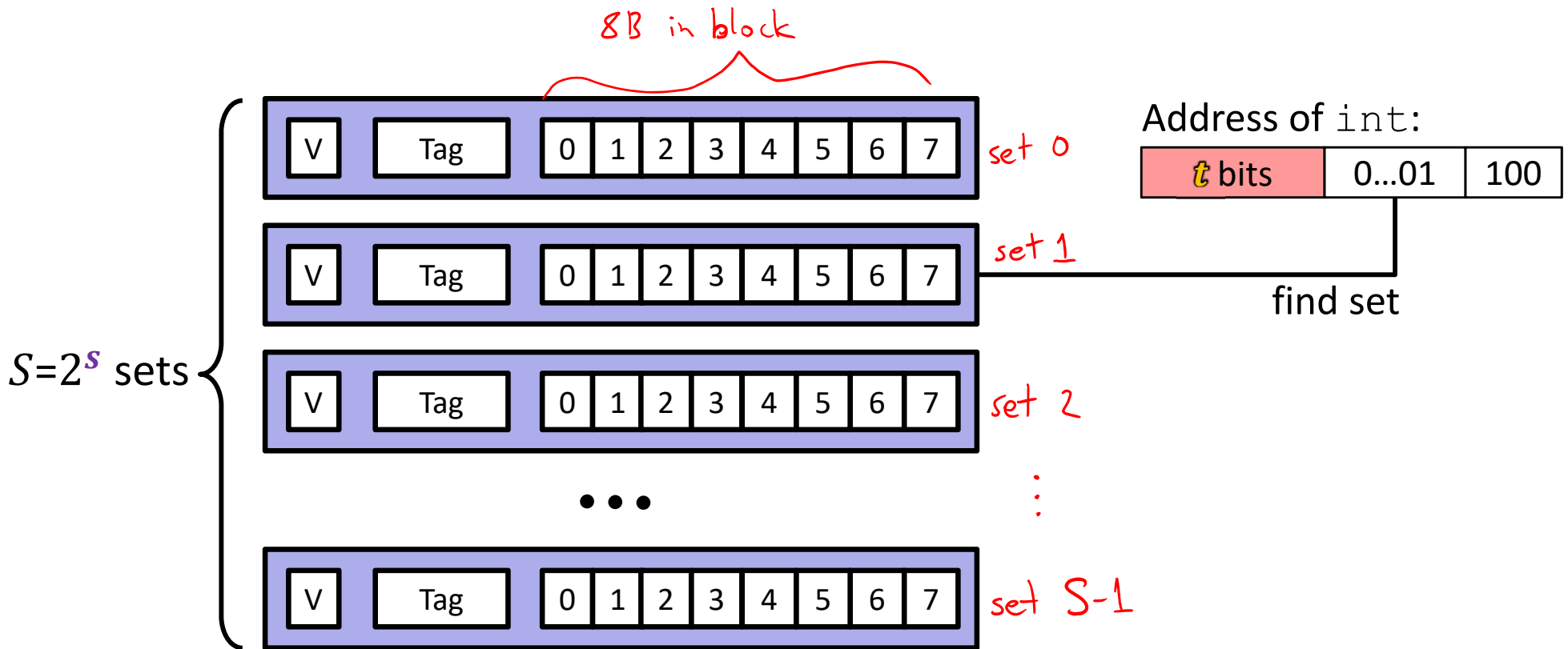

Example: Direct-Mapped Cache ($E = 1$)

Direct-mapped: One line per set

Block Size $K = 8$ B

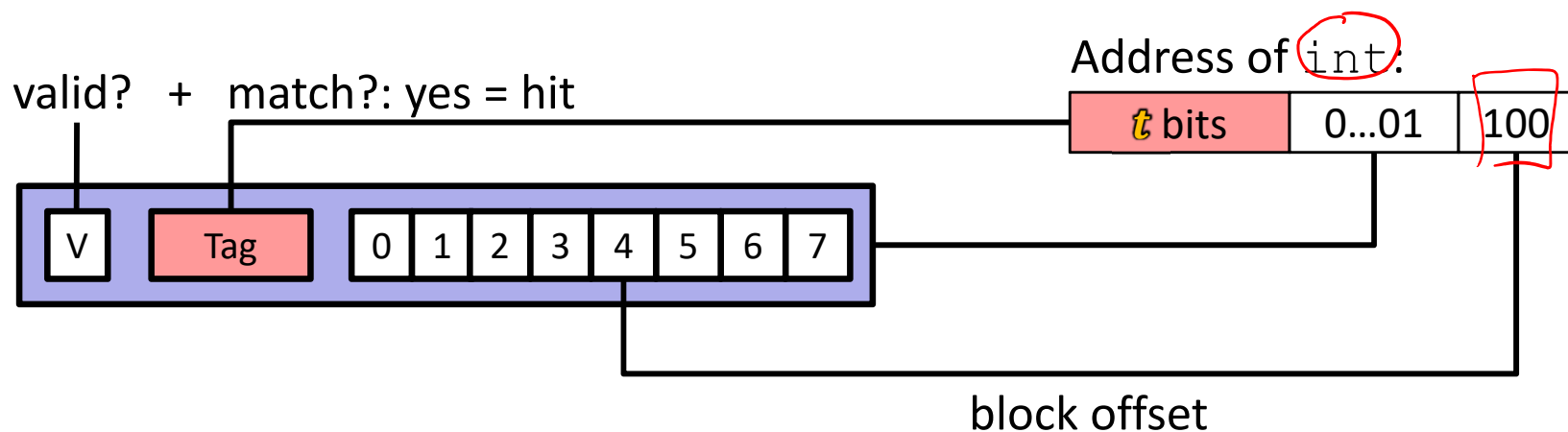

Example: Direct-Mapped Cache ($E = 1$)

Direct-mapped: One line per set
 Block Size $K = 8$ B

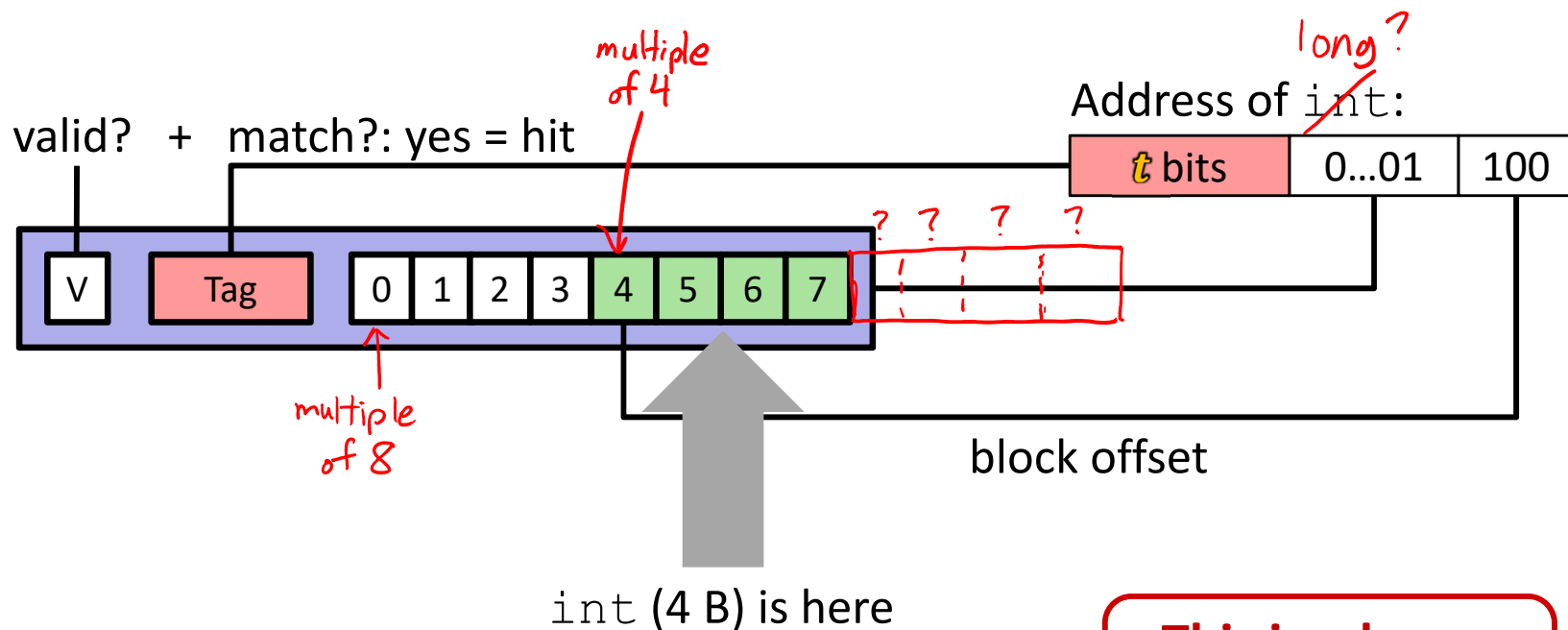

This is why we want alignment!

No match? Then old line gets evicted and replaced

no unnecessary extra cache accesses across block boundaries

Example: Set-Associative Cache ($E = 2$)

2-way: Two lines per set
 Block Size $K = 8$ B

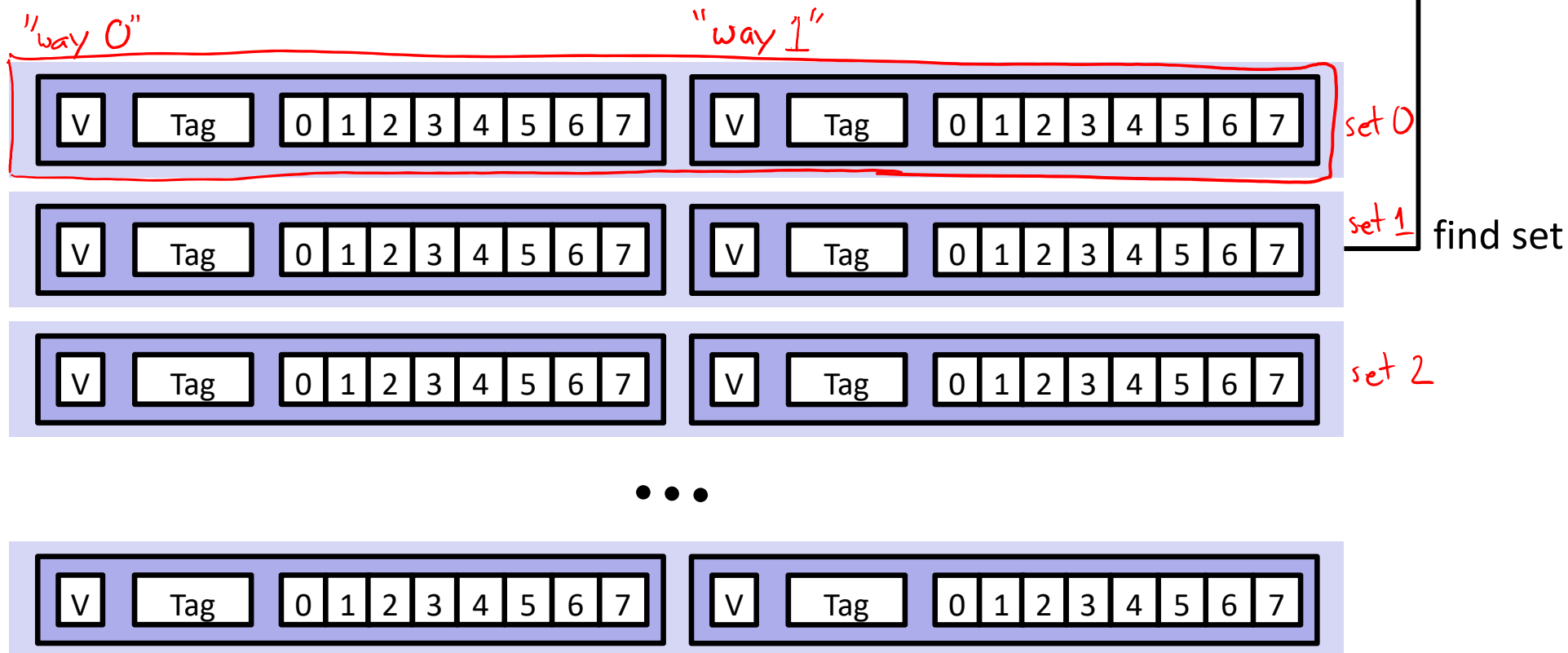
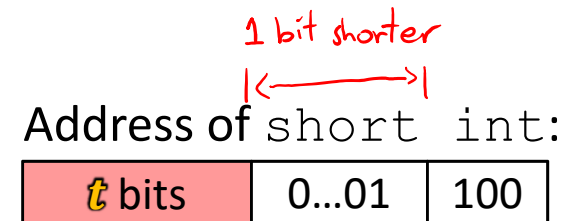

Example: Set-Associative Cache ($E = 2$)

2-way: Two lines per set
 Block Size $K = 8$ B

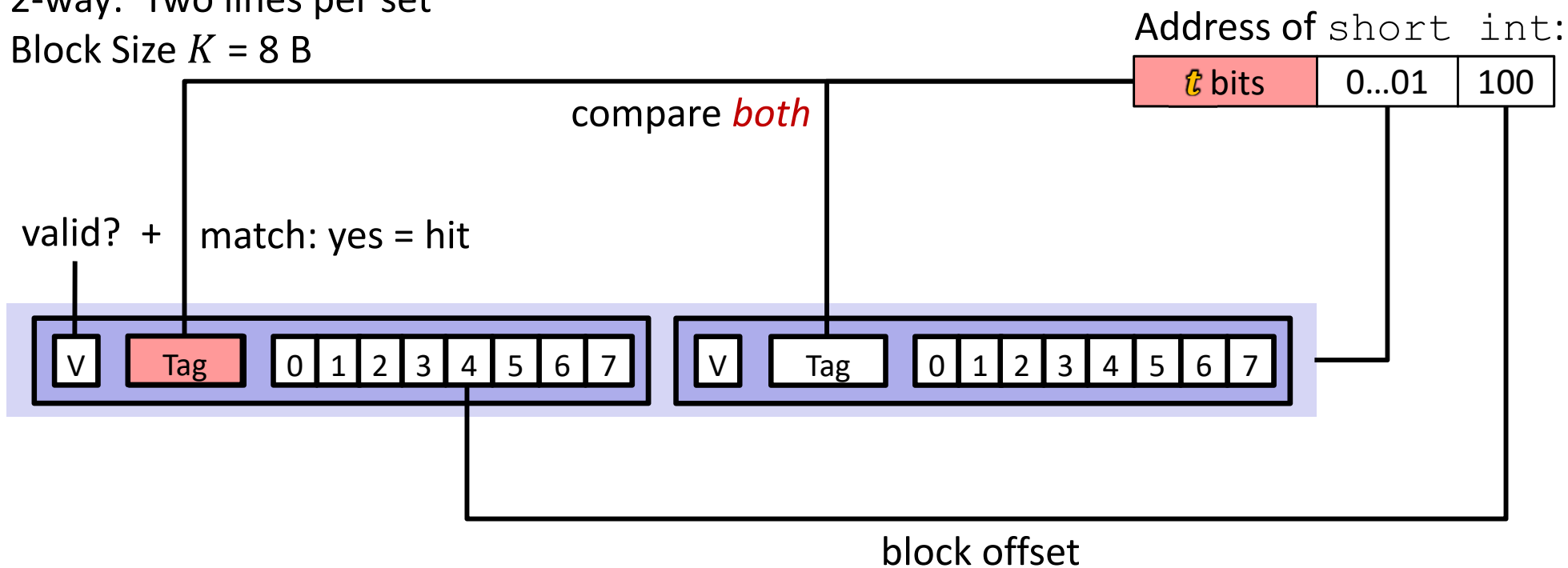

Example: Set-Associative Cache ($E = 2$)

2-way: Two lines per set
 Block Size $K = 8$ B

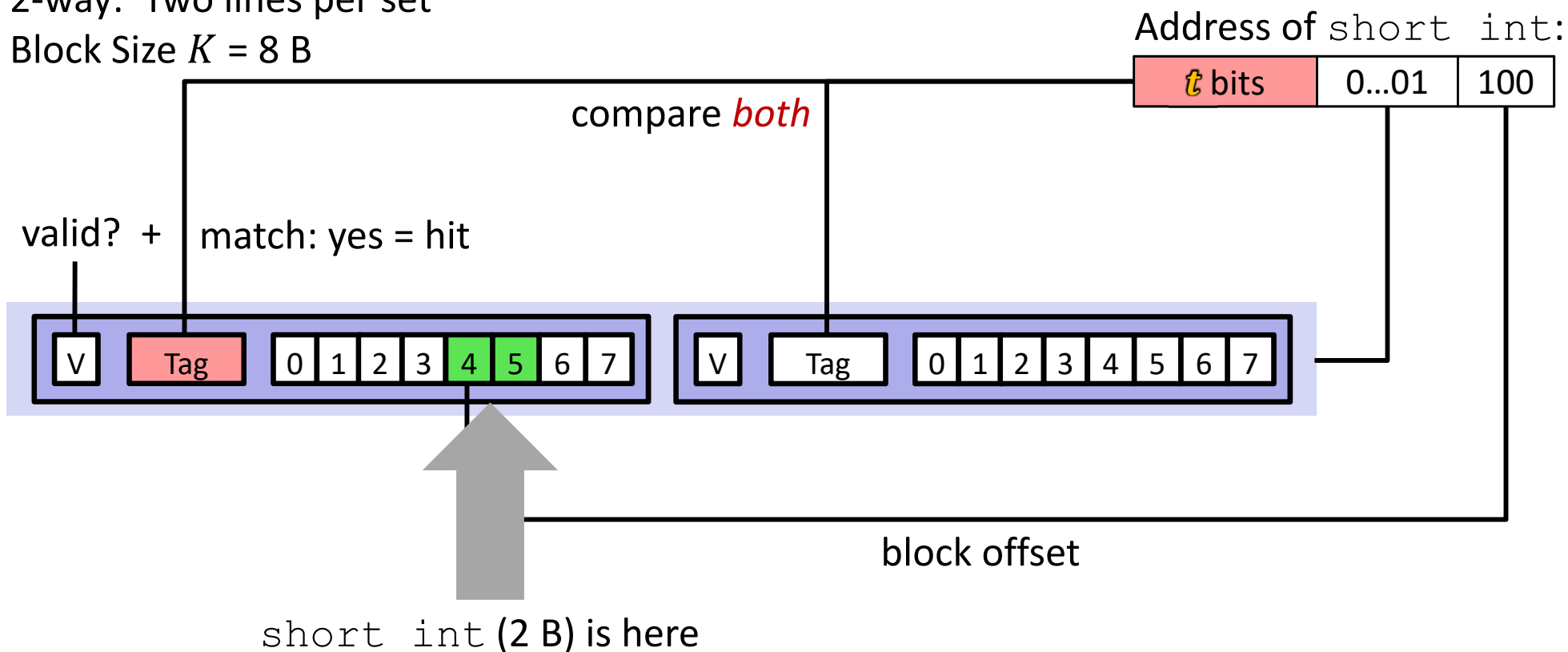

No match?

- One line in set is selected for eviction and replacement
- Replacement policies: random, least recently used (LRU), ...

Types of Cache Misses: 3 C's!

- ❖ **Compulsory** (cold) miss
 - Occurs on first access to a block
- ❖ **Conflict** miss
 - Conflict misses occur when the cache is large enough, but multiple data objects all map to the same slot
 - *e.g.* referencing blocks 0, 8, 0, 8, ... could miss every time
 - Direct-mapped caches have more conflict misses than E -way set-associative (where $E > 1$)
- ❖ **Capacity** miss
 - Occurs when the set of active cache blocks (the *working set*) is larger than the cache (just won't fit, even if cache was *fully-associative*)
 - **Note:** *Fully-associative* only has Compulsory and Capacity misses

Example Code Analysis Problem

- Assuming the cache starts cold (all blocks invalid) and `sum`, `i`, and `j` are stored in registers, calculate the **miss rate**: 1/4
 - $m = 12$ bits, $C = 256$ B, $K = 32$ B, $E = 2$

8 bytes per element

```
#define SIZE 8
long ar[SIZE][SIZE], sum = 0; // &ar=0x800
for (int i = 0; i < SIZE; i++)
    for (int j = 0; j < SIZE; j++)
        sum += ar[i][j];
```



Challenge: what is the miss rate if we switch the ordering of the for-loops?