

Roadmap

C:

```
car *c = malloc(sizeof(car));
c->miles = 100;
c->gals = 17;
float mpg = get_mpg(c);
free(c);
```

Java:

```
Car c = new Car();
c.setMiles(100);
c.setGals(17);
float mpg =
    c.getMPG();
```

Assembly
language:

```
get_mpg:
    pushq   %rbp
    movq    %rsp, %rbp
    ...
    popq    %rbp
    ret
```

Machine
code:

```
0111010000011000
100011010000010000000010
1000100111000010
110000011111101000011111
```

Computer
system:

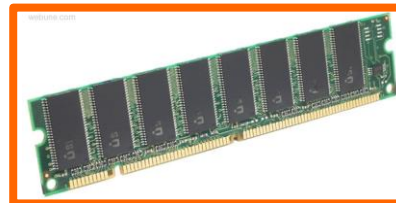

OS:



Memory & data
Integers & floats
Machine code & C
x86 assembly
Procedures & stacks
Arrays & structs
Memory & caches
Processes
Virtual memory
Memory allocation
Java vs. C

Virtual Memory (VM)

- Overview and motivation
- VM as tool for caching
- Address translation
- VM as tool for memory management
- VM as tool for memory protection

Again: Processes

- **Definition: A *process* is an instance of a running program**
 - One of the most important ideas in computer science
 - Not the same as “program” or “processor”
- **Process provides each program with **two key abstractions**:**
 - Logical control flow
 - Each process seems to have exclusive use of the CPU
 - Private virtual address space
 - Each process seems to have exclusive use of main memory
- **How are these illusions maintained?**
 - Process executions interleaved (multi-tasking) – done...
 - Address spaces managed by virtual memory system – **now!**

Memory as we know it so far... is virtual!

■ Programs refer to *virtual* memory addresses

- `movq (%rdi), %rax`
- Conceptually memory is just a very large array of bytes
- Each byte has its own address
- System provides address space private to particular “process”

■ Allocation: Compiler and run-time system

- Where different program objects should be stored
- All allocation within single virtual address space

■ But...

- We probably don't have exactly 2^w bytes of physical memory.
 - We definitely do not have 2^{64} bytes of physical memory.
- We *certainly* don't have 2^w bytes of physical memory for every process.
- We have multiple processes that usually should not interfere with each other, but sometimes should share code or data.

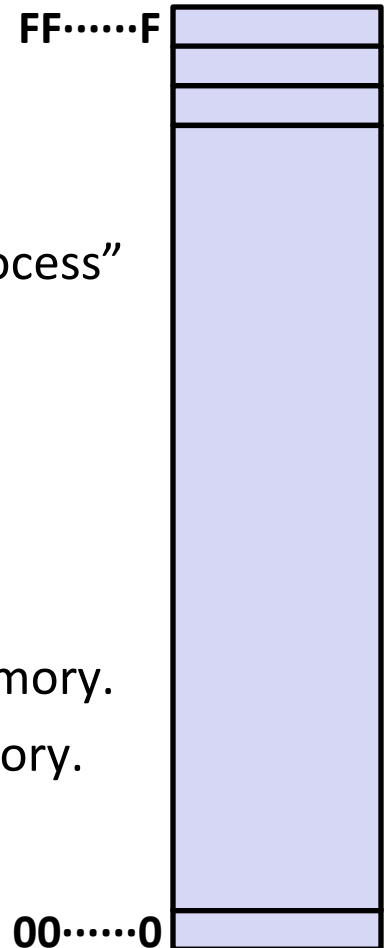

Problem 1: How Does Everything Fit?

64-bit virtual addresses can address
several exabytes
(18,446,744,073,709,551,616 bytes)

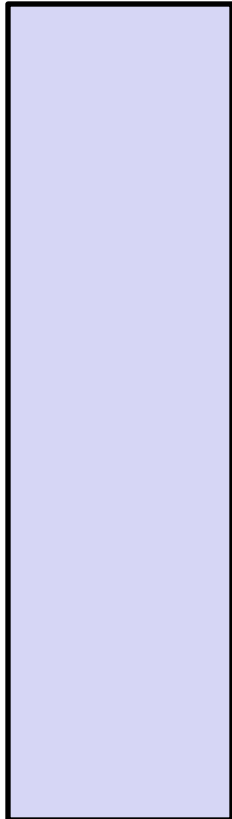

1 virtual address space per process,
with many processes...

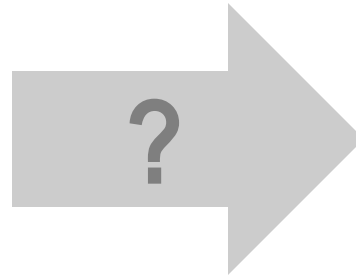

Physical main memory offers
a few gigabytes
(e.g. 8,589,934,592 bytes)

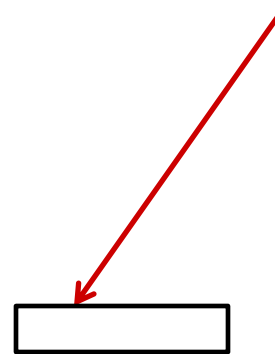

(Actually, **physical** memory is smaller than
the period at the end of this sentence
compared to the **virtual** address space.)

Problem 2: Memory Management

We have multiple processes:

Process 1
Process 2
Process 3
...
Process n

X

Each process has...

stack
heap
.text
.data
...



Physical main memory

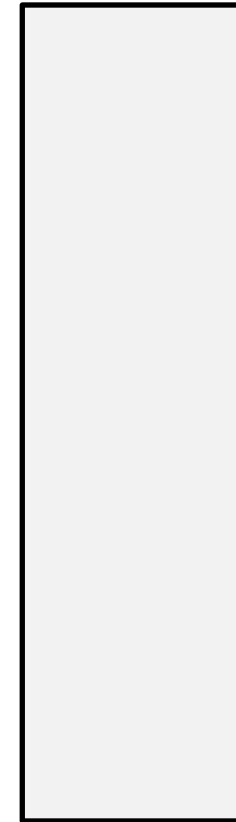

Problem 3: How To Protect

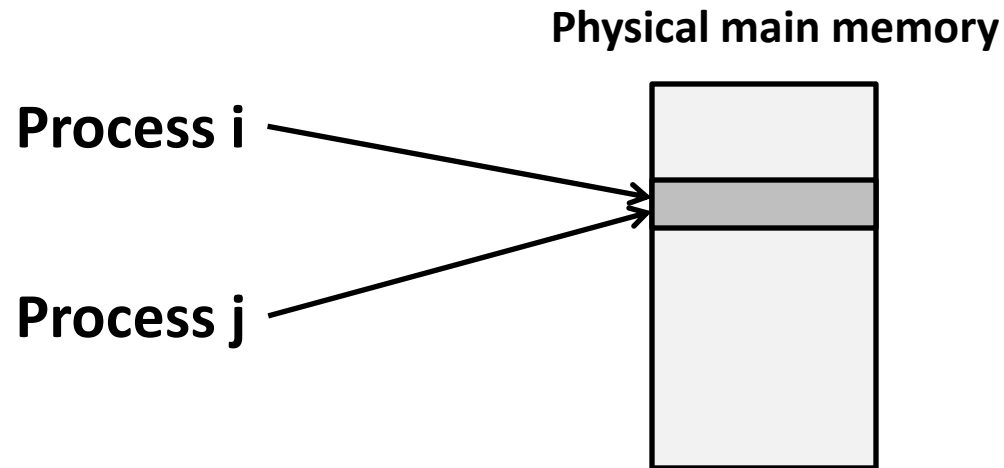

Problem 4: How To Share?

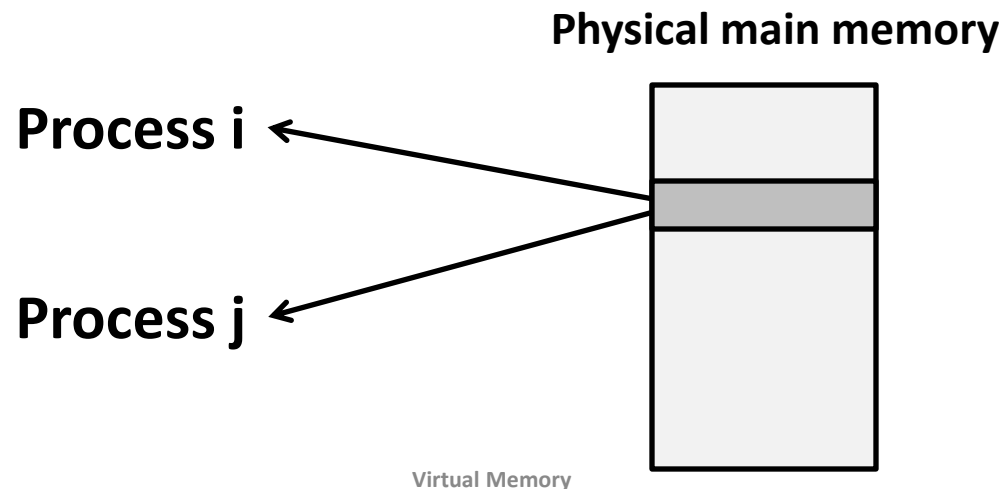

How can we solve these problems?

- **Fitting a huge address space into a tiny physical memory**
- **Managing the address spaces of multiple processes**
- **Protecting processes from stepping on each other's memory**
- **Allowing processes to share common parts of memory**

Indirection

- “Any problem in computer science can be solved by adding another level of indirection.” –David Wheeler, inventor of the subroutine (a.k.a. procedure)

- **Without Indirection**

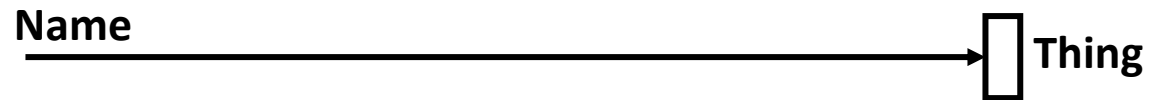

- **With Indirection**

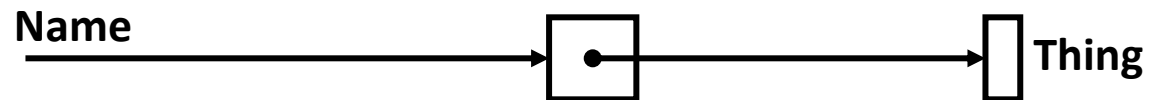

What if I want to move Thing?

Indirection

- **Indirection:** the ability to reference something using a name, reference, or container instead the value itself. A flexible mapping between a name and a thing allows changing the thing without notifying holders of the name.

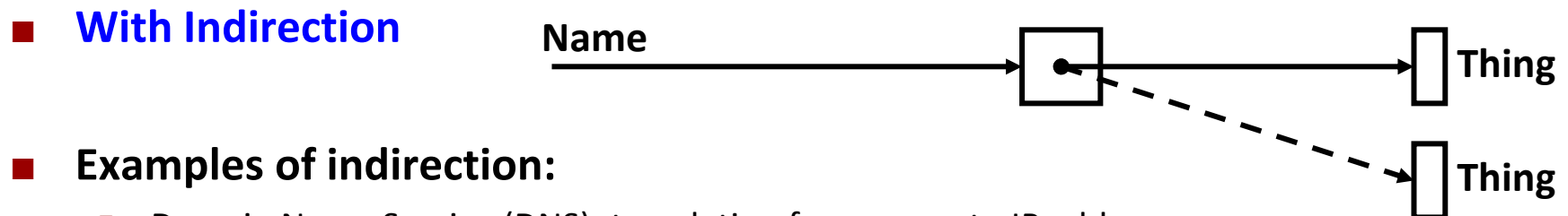
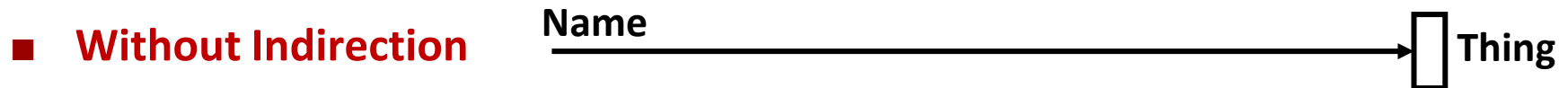

- **Examples of indirection:**

- Domain Name Service (DNS): translation from name to IP address
- phone system: cell phone number portability
- snail mail: mail forwarding
- 911: routed to local office
- Dynamic Host Configuration Protocol (DHCP): local network address assignment
- call centers: route calls to available operators, etc.

Indirection in Virtual Memory

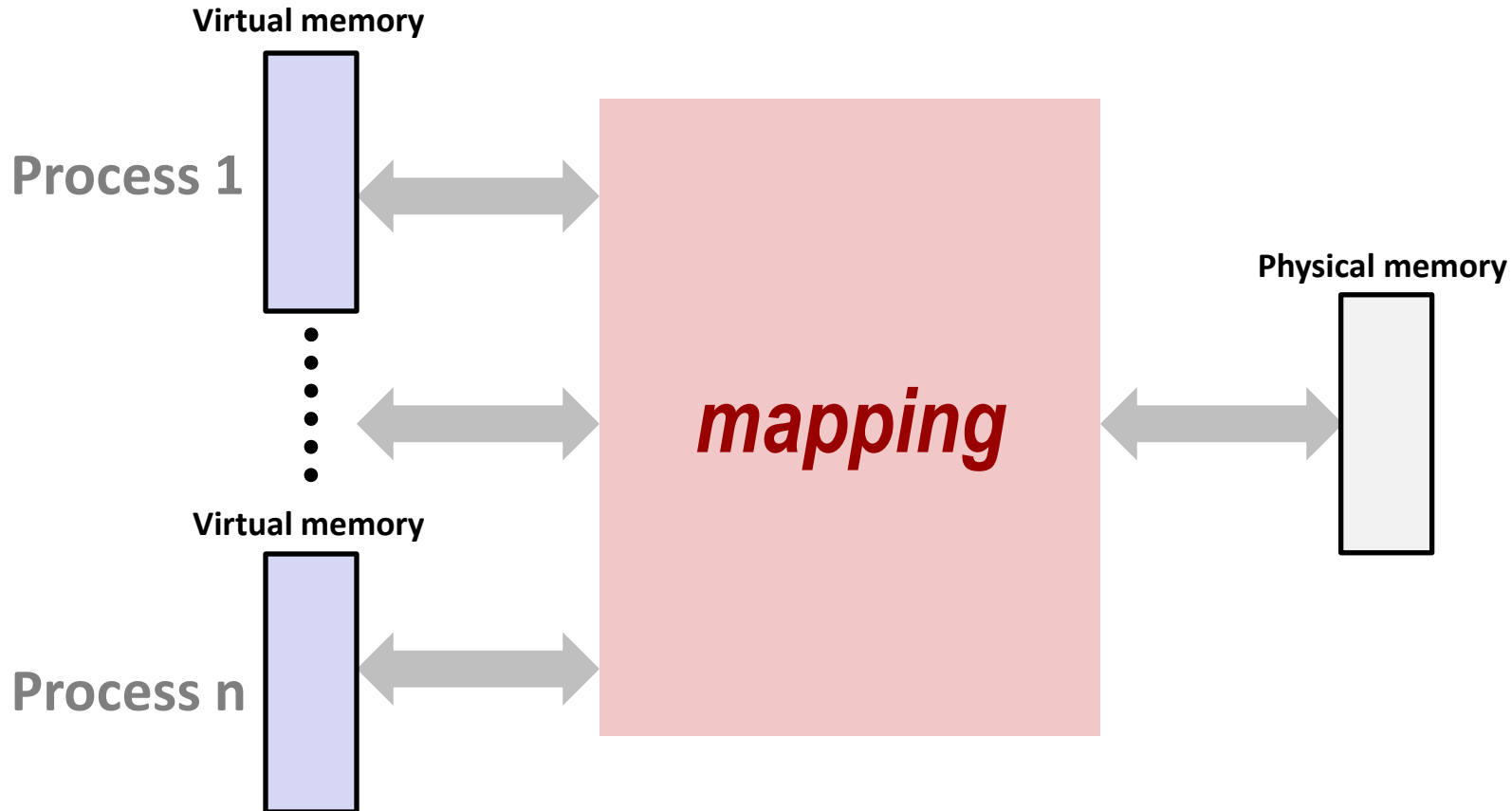

- Each process gets its own private virtual address space
- Solves the previous problems

Address Spaces

- **Virtual address space:** Set of $N = 2^n$ virtual addresses
 $\{0, 1, 2, 3, \dots, N-1\}$
- **Physical address space:** Set of $M = 2^m$ physical addresses ($n \geq m$)
 $\{0, 1, 2, 3, \dots, M-1\}$
- **Every byte in main memory has:**
 - one physical address
 - zero, one, *or more* virtual addresses

Mapping

A virtual address can be mapped to either physical memory or disk.

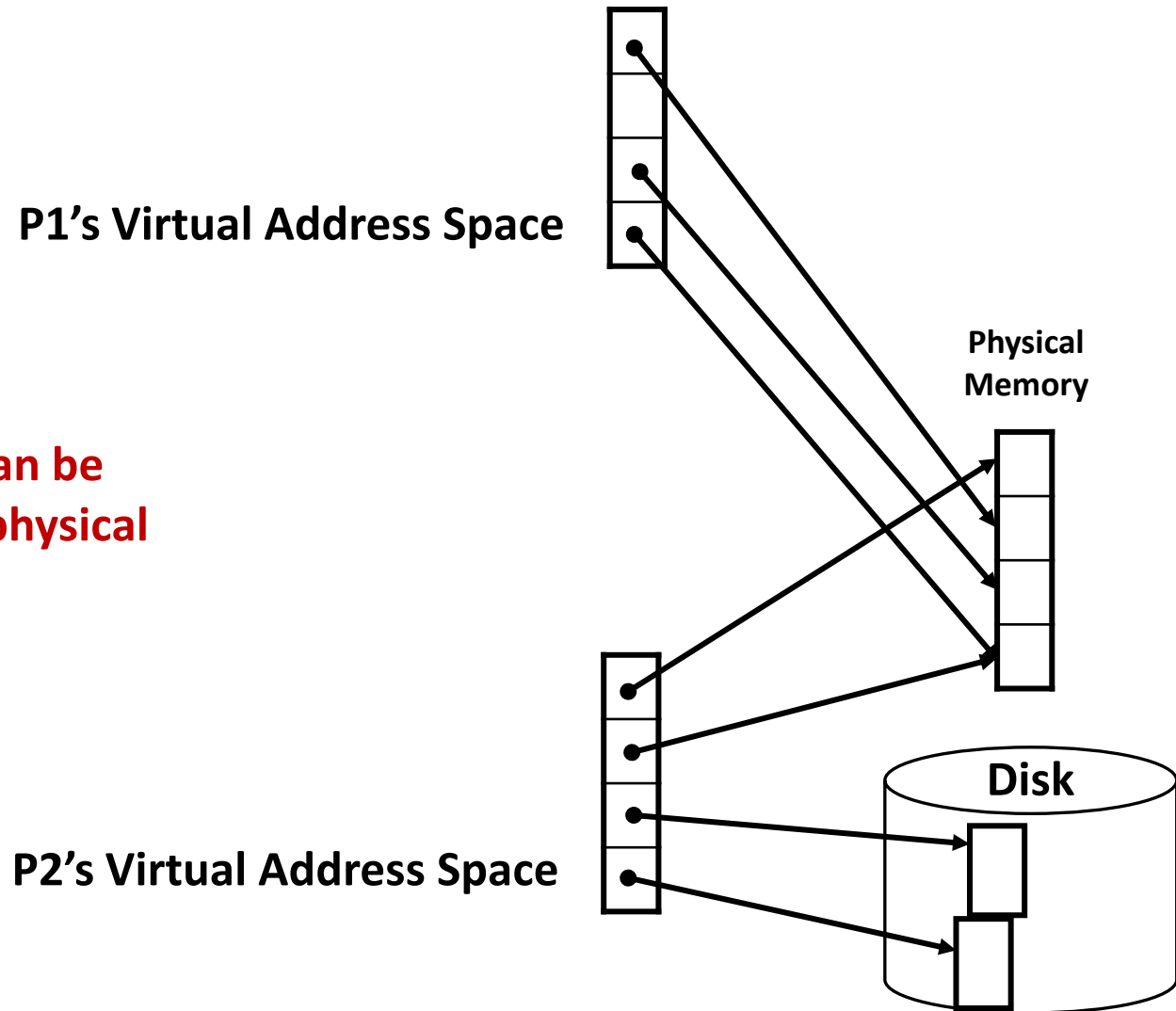

A System Using Physical Addressing

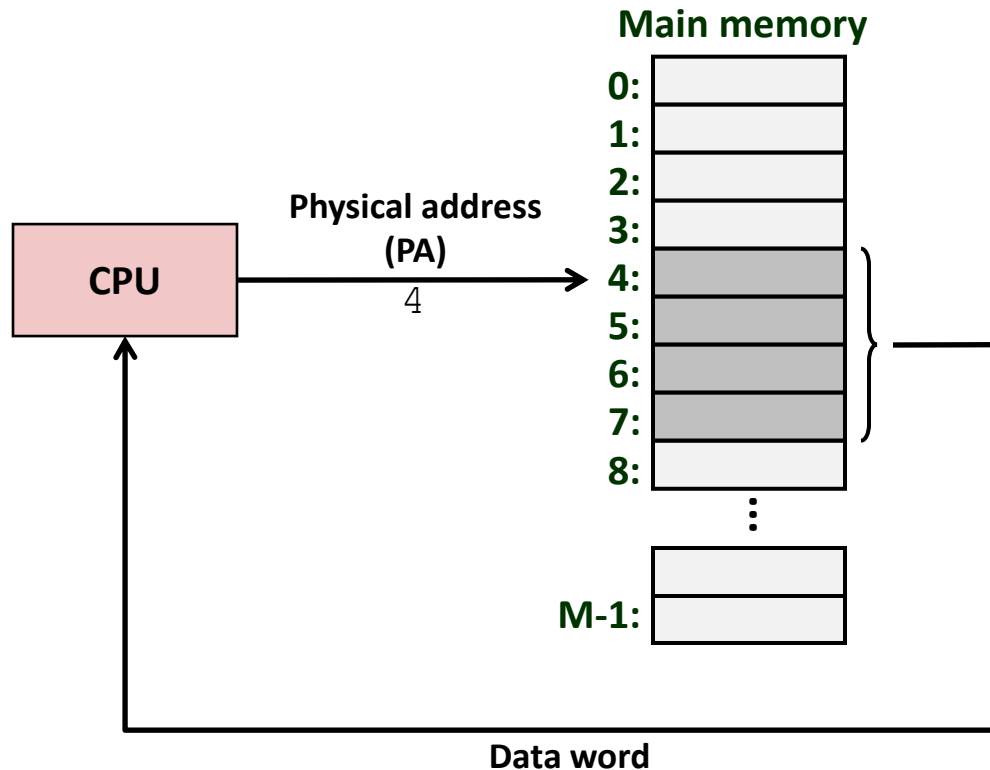

- Used in “simple” systems with (usually) just one process:
 - embedded microcontrollers in devices like cars, elevators, and digital picture frames

A System Using Virtual Addressing

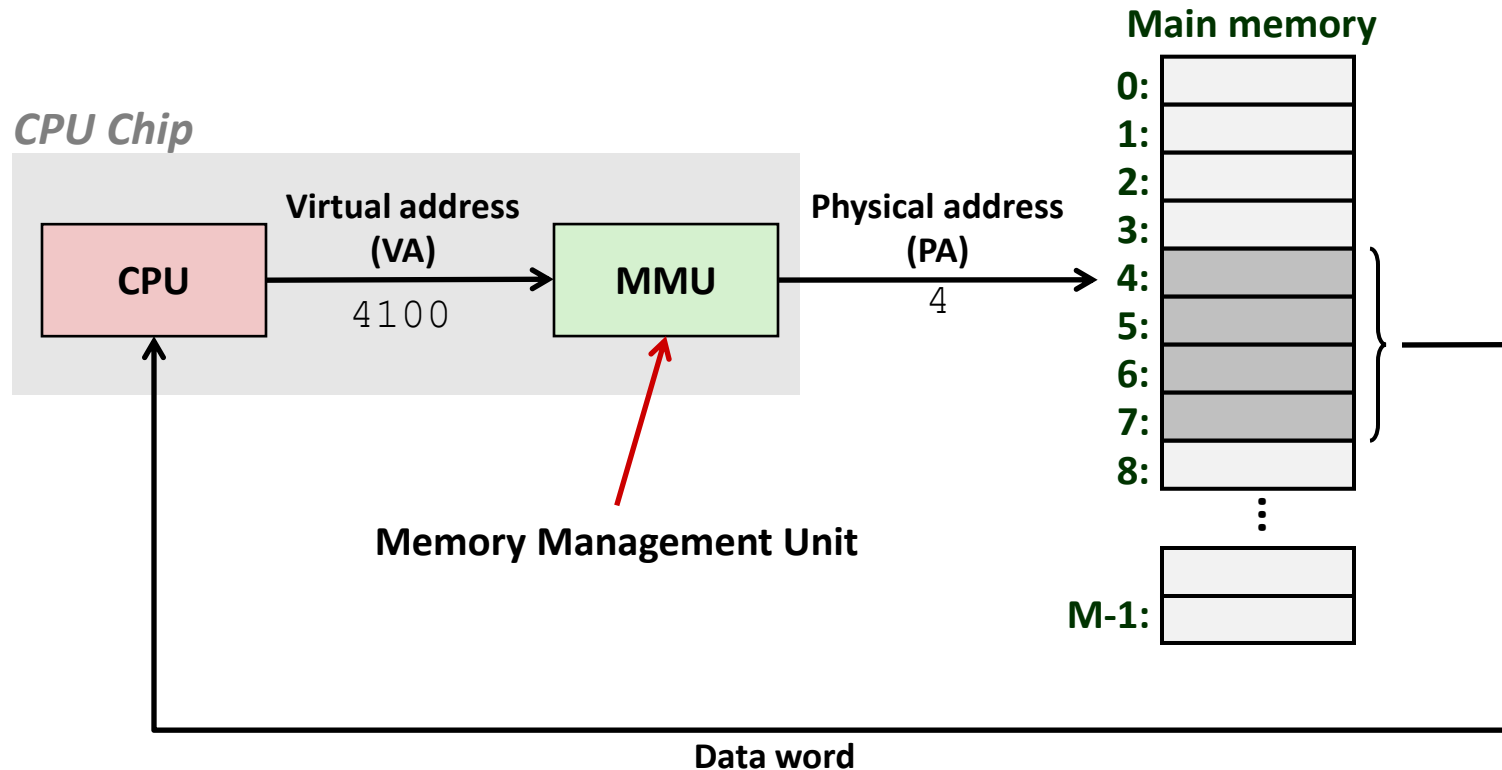

- Physical addresses are *completely invisible to programs*.
- Used in all modern desktops, laptops, servers, smartphones...
- One of the great ideas in computer science

Why Virtual Memory (VM)?

- **Efficient use of limited main memory (RAM)**
 - Use RAM as a cache for the parts of a virtual address space
 - some non-cached parts stored on disk
 - some (unallocated) non-cached parts stored nowhere
 - Keep only active areas of virtual address space in memory
 - transfer data back and forth as needed
- **Simplifies memory management for programmers**
 - Each process gets the same full, private linear address space
- **Isolates address spaces**
 - One process can't interfere with another's memory
 - because they operate in different address spaces
 - User process cannot access privileged information
 - different sections of address spaces have different permissions

VM and the Memory Hierarchy

- Think of virtual memory as array of $N = 2^n$ contiguous bytes.
- **Pages** of virtual memory are usually stored in physical memory, but sometimes spill to disk.
 - Pages are another unit of aligned memory (size is $P = 2^p$ bytes)
 - Each virtual page can be stored in *any* physical page.

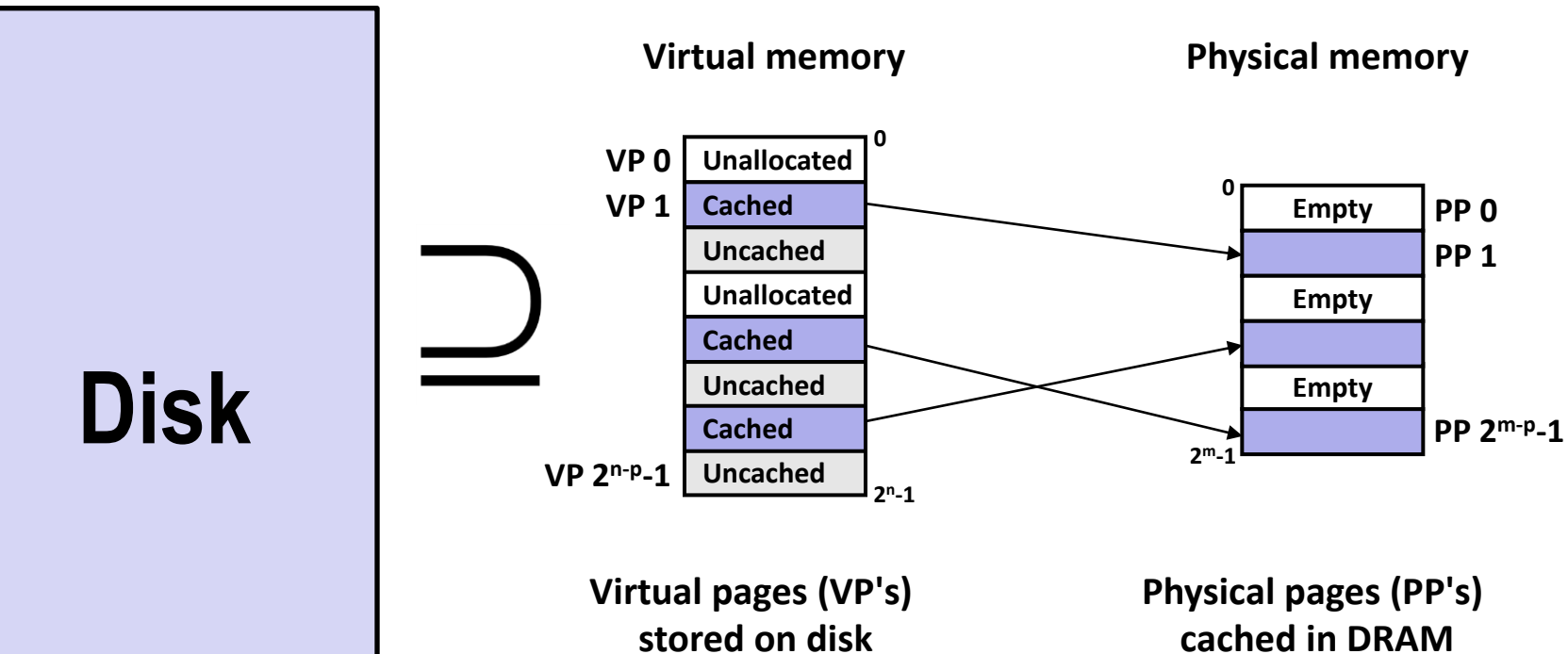

or: Virtual Memory as DRAM Cache for Disk

- Think of virtual memory as an array of $N = 2^n$ contiguous bytes stored *on a disk*.
- Then physical main memory is used as a *cache* for the virtual memory array
 - The cache blocks are called *pages* (size is $P = 2^p$ bytes)

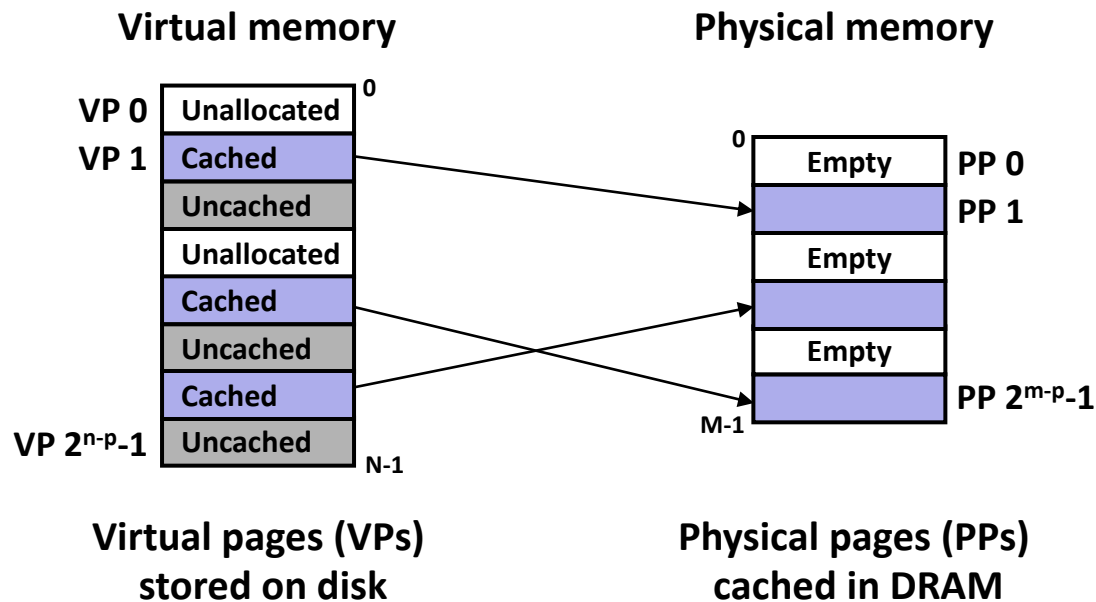

Memory Hierarchy: Core 2 Duo

Not drawn to scale

SRAM

Static Random Access Memory

DRAM

Dynamic Random Access Memory

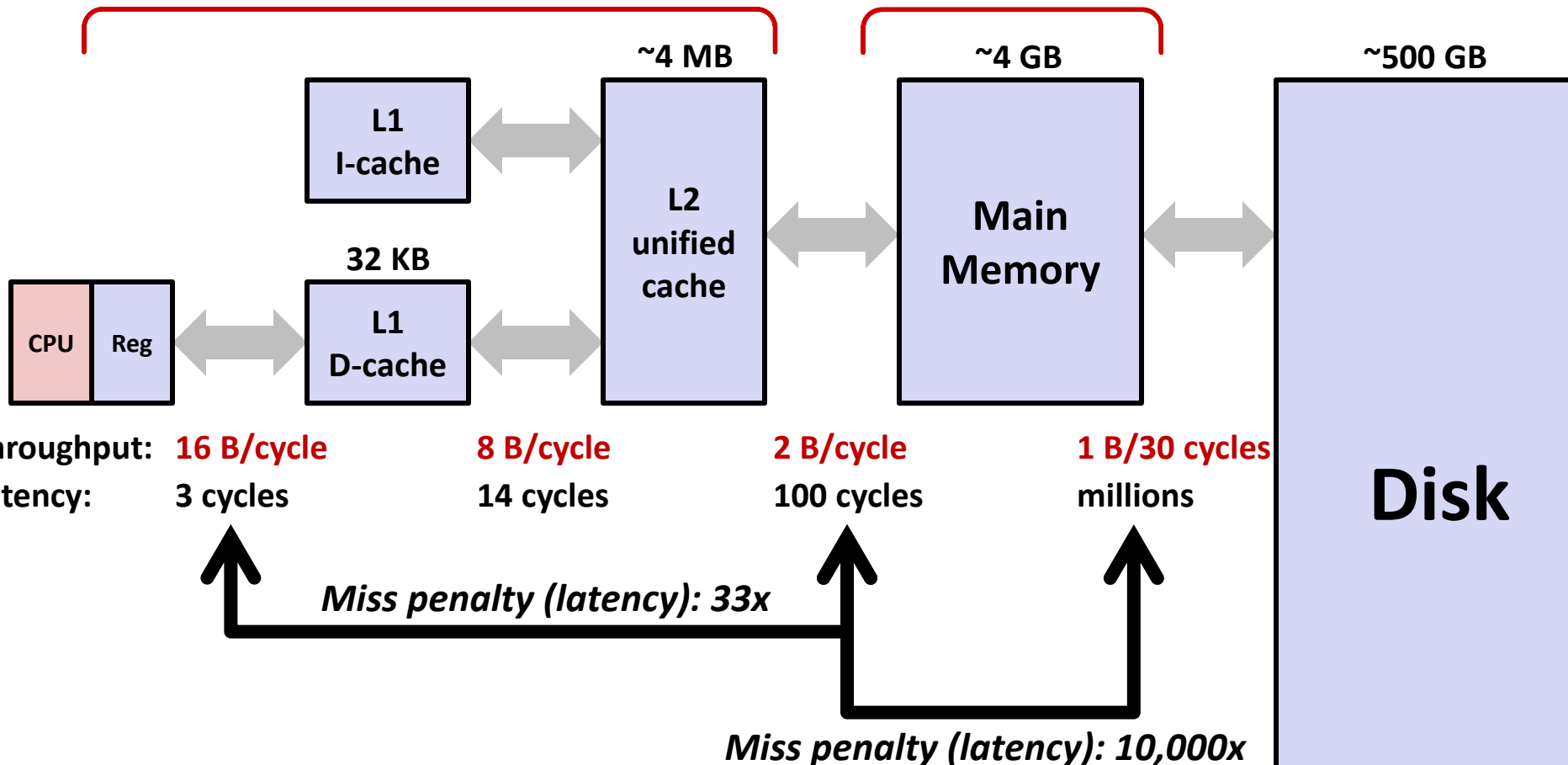

Virtual Memory Design Consequences

- **Large *page* size: typically 4-8 KB, sometimes up to 4 MB**
- **Fully associative**
 - Any virtual page can be placed in any physical page
 - Requires a “large” mapping function – different from CPU caches
- **Highly sophisticated, expensive replacement algorithms in OS**
 - Too complicated and open-ended to be implemented in hardware
- **Write-back rather than write-through**

Address Translation

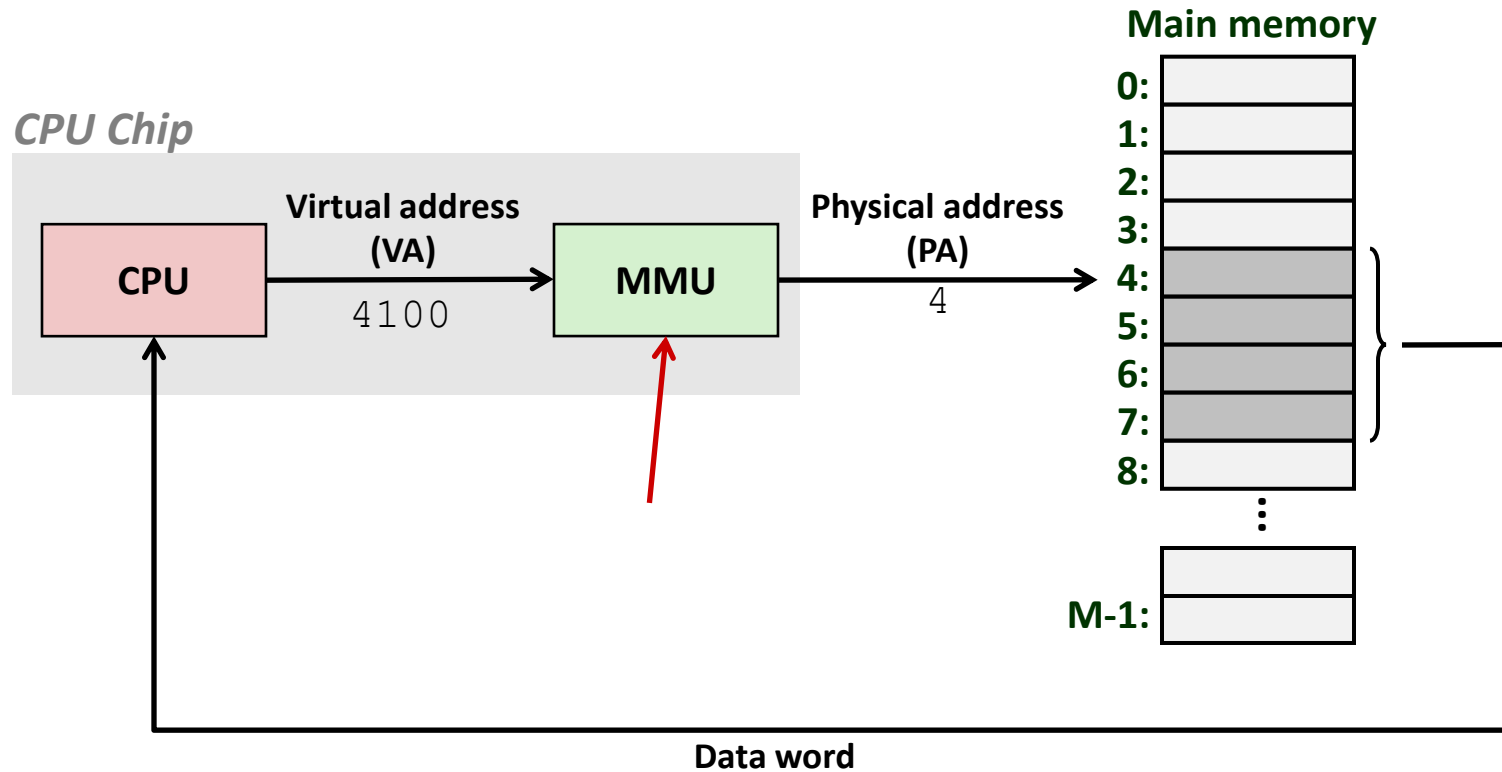

How do we perform the virtual -> physical address translation?

Address Translation: Page Tables

- A **page table** is an array of **page table entries** (PTEs) that maps virtual pages to physical pages.

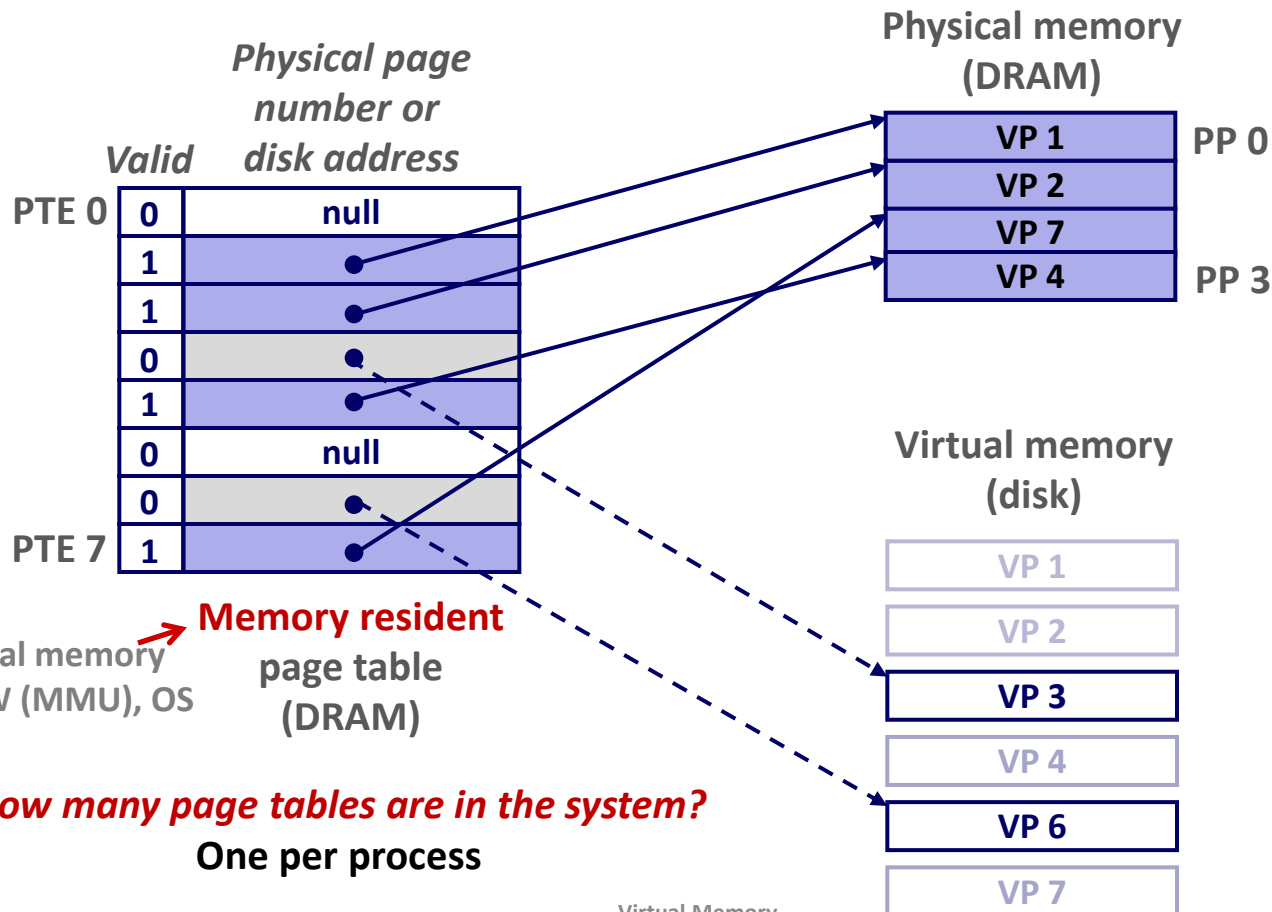

Summary of Address Translation Symbols

■ Basic Parameters

- $N = 2^n$: Number of addresses in virtual address space
- $M = 2^m$: Number of addresses in physical address space
- $P = 2^p$: Page size (bytes)

■ Components of the virtual address (VA)

- TLBI: TLB index
- TLBT: TLB tag
- VPO: Virtual page offset
- VPN: Virtual page number

■ Components of the physical address (PA)

- PPO: Physical page offset (same as VPO)
- PPN: Physical page number

Address Translation With a Page Table

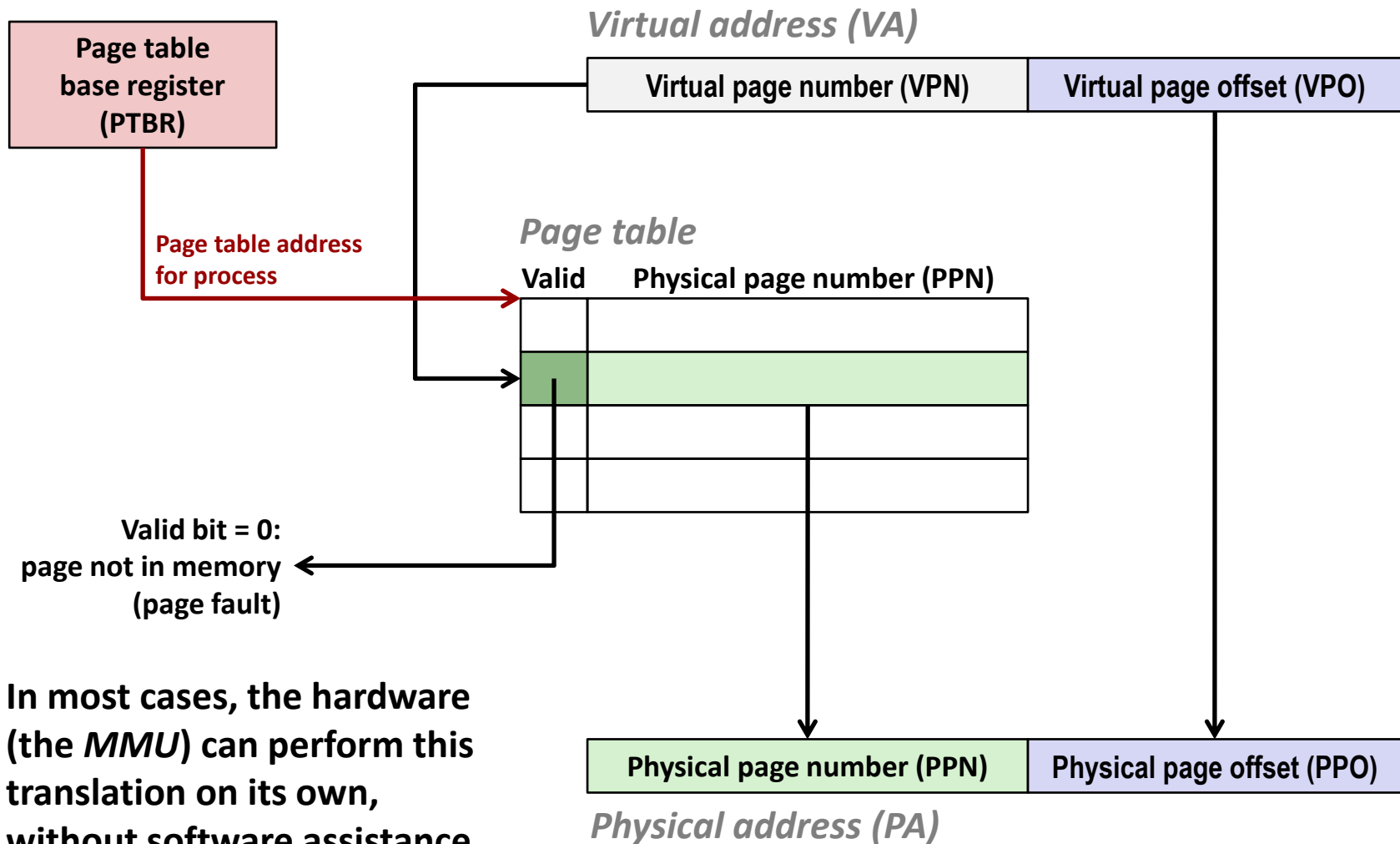

In most cases, the hardware (the *MMU*) can perform this translation on its own, without software assistance

This feels familiar...

Page Hit

- **Page hit:** reference to VM byte that is in physical memory

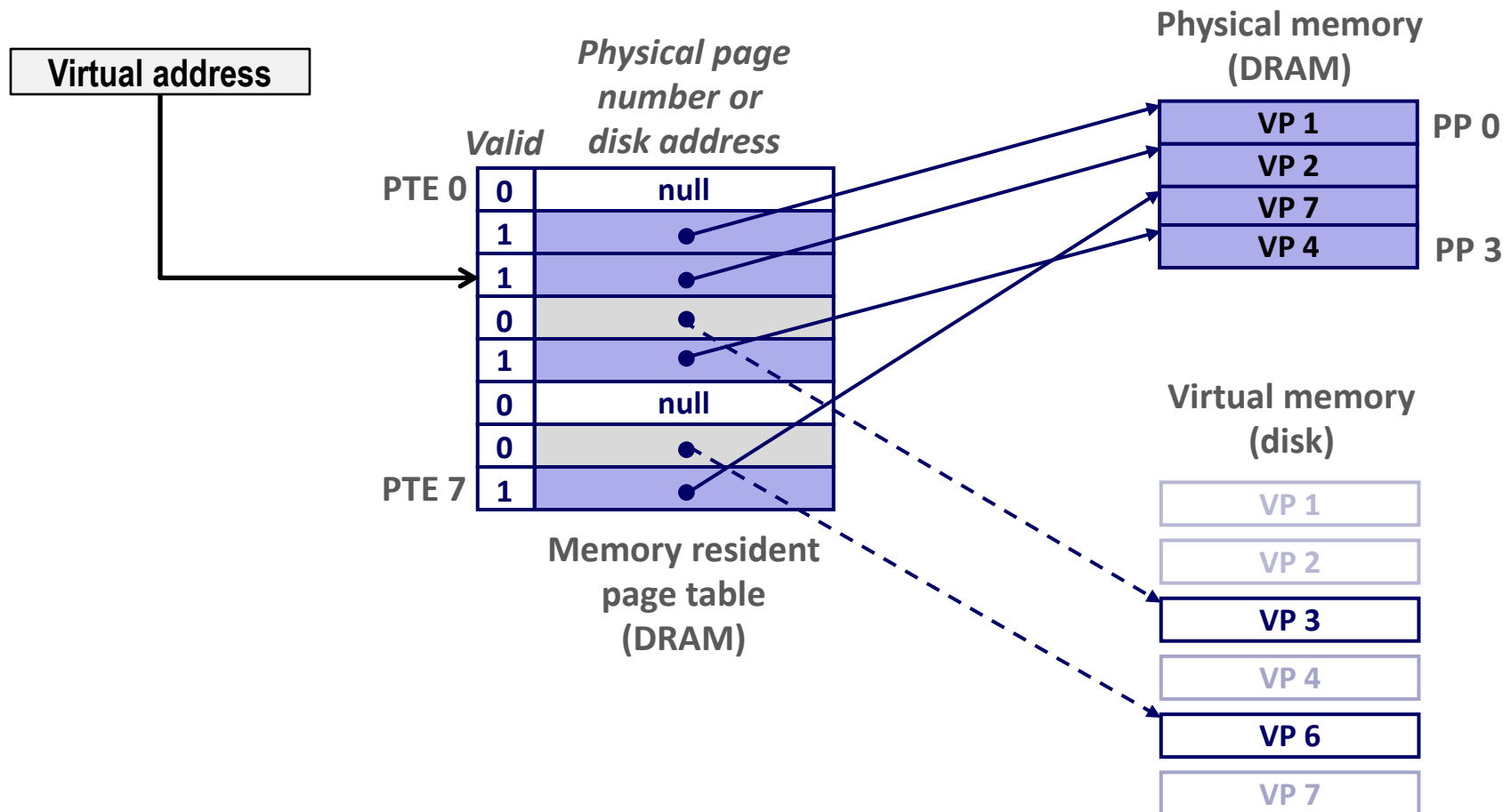

Page Fault

- **Page fault:** reference to VM byte that is **NOT** in physical memory

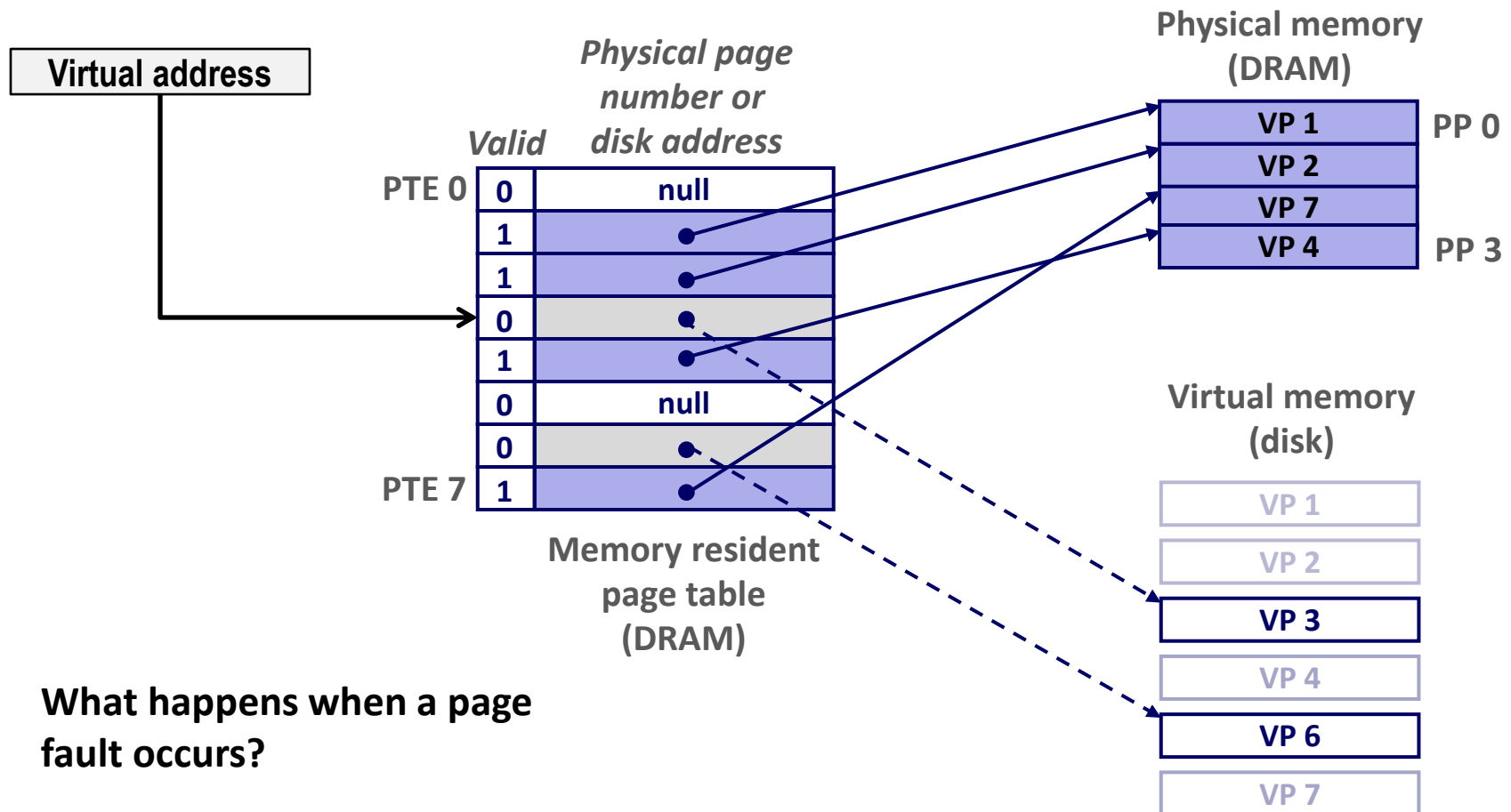

Fault Example: Page Fault

- User writes to memory location
- That portion (page) of user's memory is currently on disk

```
int a[1000];
main ()
{
    a[500] = 13;
}
```

```
80483b7:      c7 05 10 9d 04 08 0d  movl   $0xd,0x8049d10
```

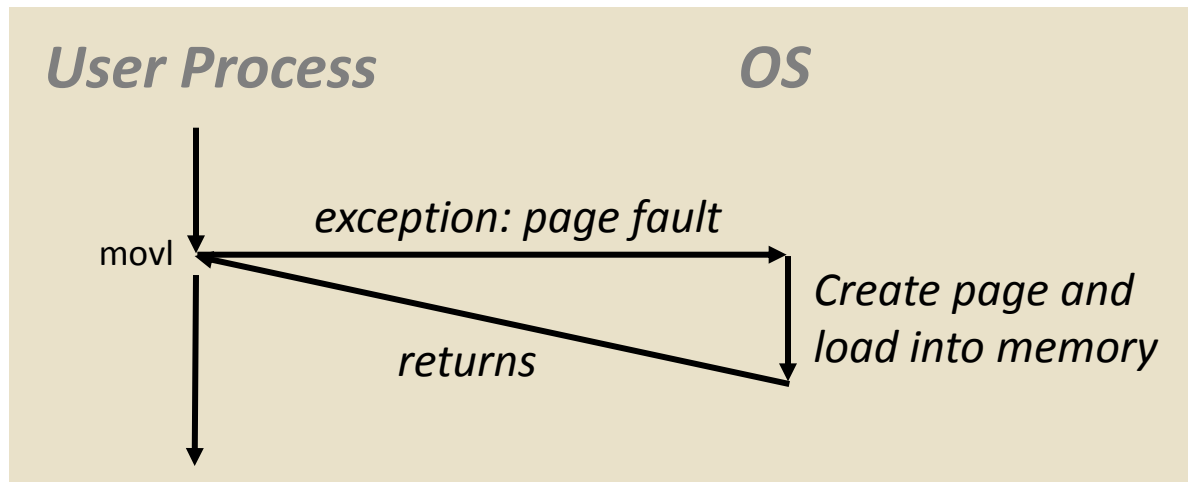

- Page fault handler must load page into physical memory
- Returns to faulting instruction: **mov** is executed *again!*
- Successful on second try

Handling Page Fault

- Page miss causes page fault (an exception)

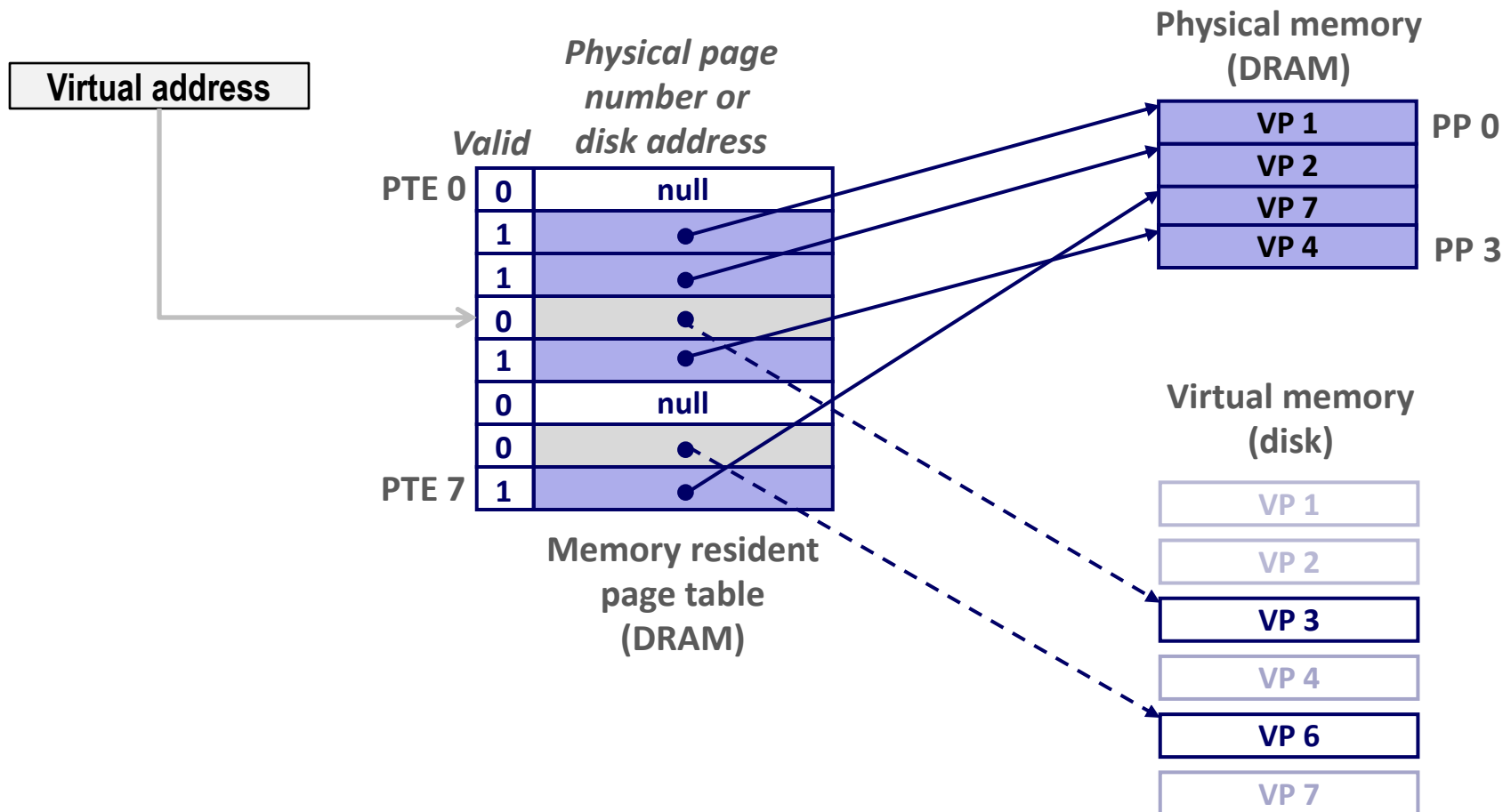

Handling Page Fault

- Page miss causes page fault (an exception)
- Page fault handler selects a *victim* to be evicted (here VP 4)

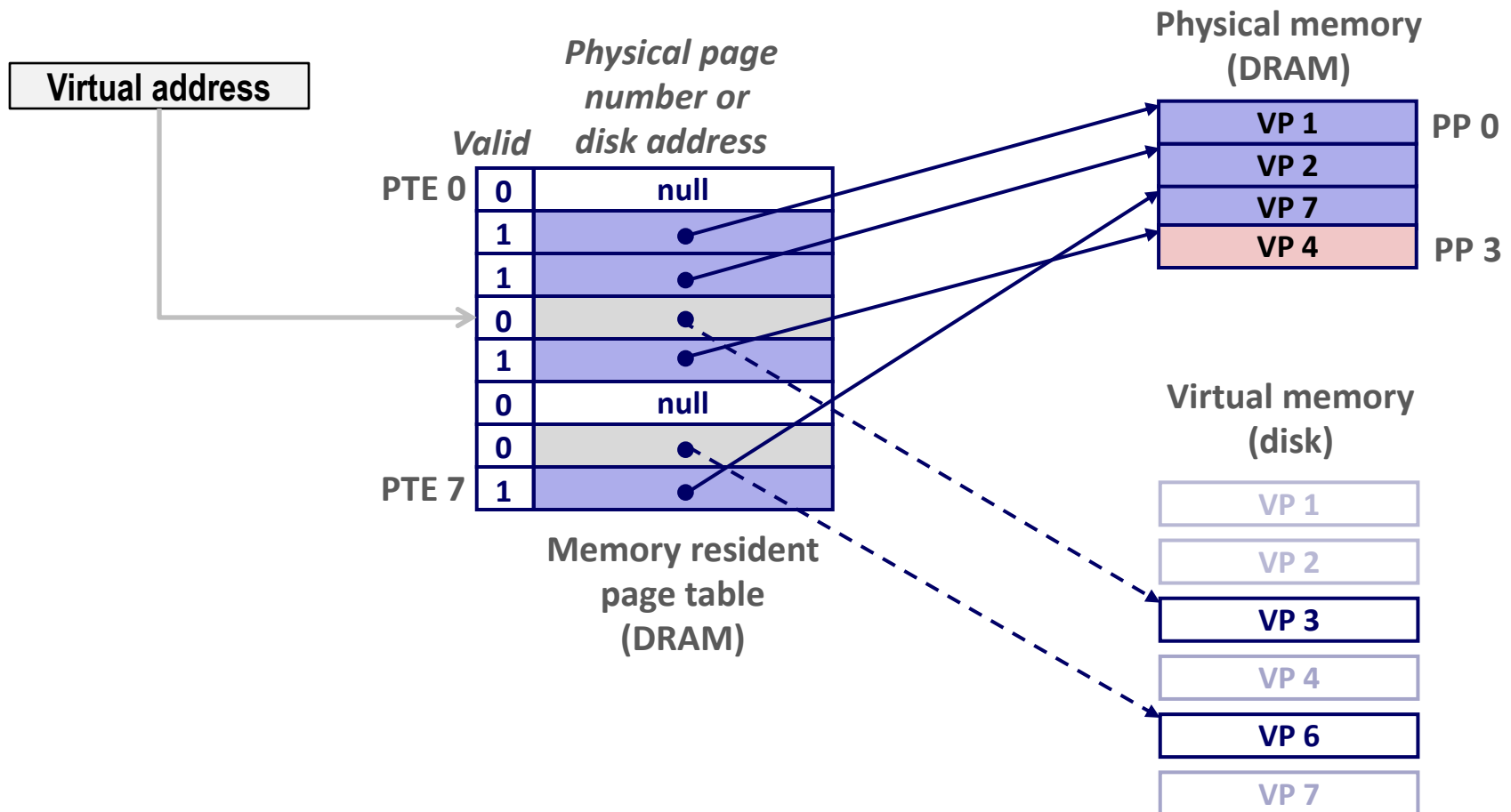

Handling Page Fault

- Page miss causes page fault (an exception)
- Page fault handler selects a *victim* to be evicted (here VP 4)

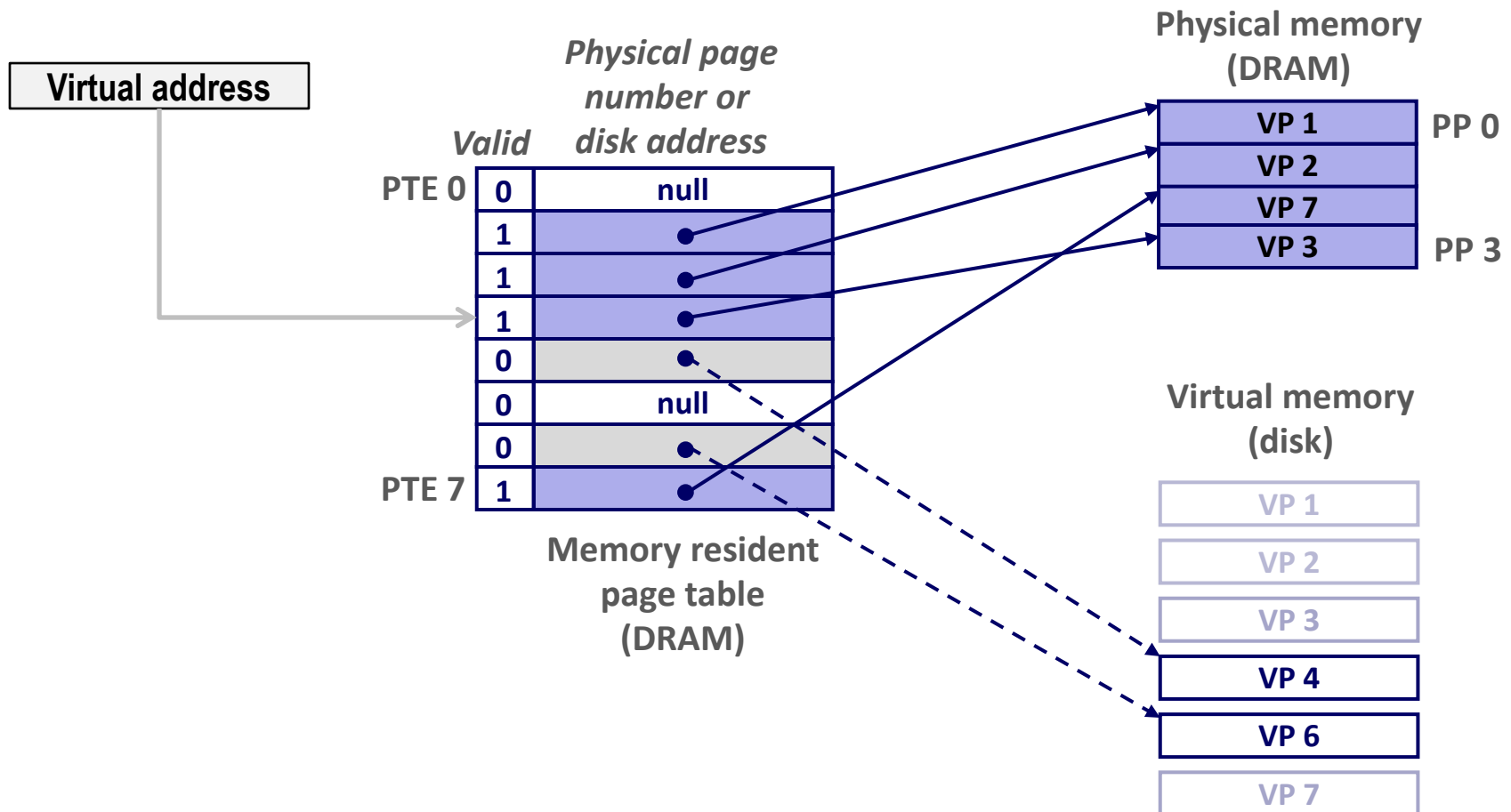

Handling Page Fault

- Page miss causes page fault (an exception)
- Page fault handler selects a *victim* to be evicted (here VP 4)
- Offending instruction is restarted: page hit!

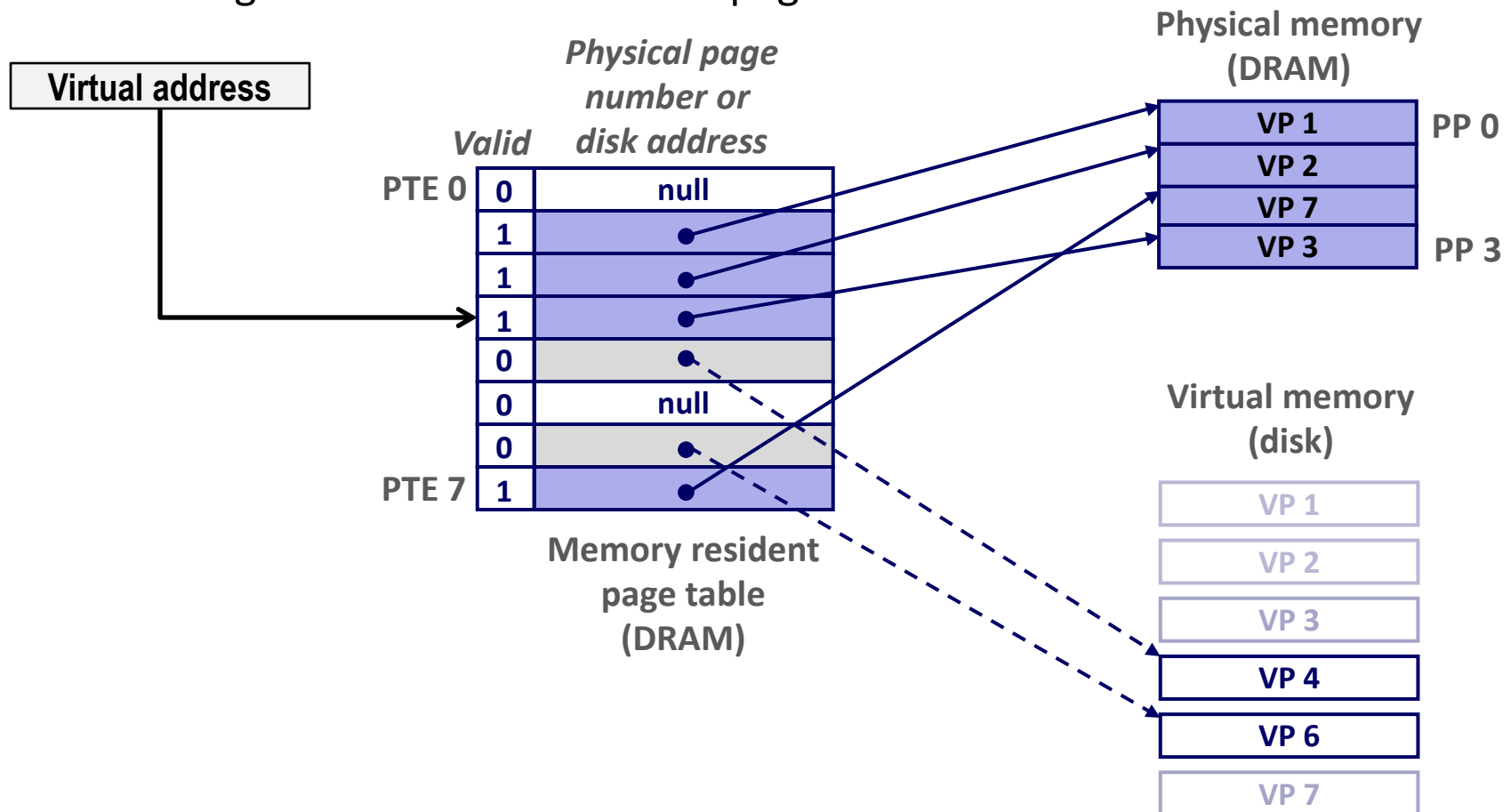

Why does it work?

Why does VM work on RAM/disk? Locality.

- Virtual memory works well for avoiding disk accesses because of locality
 - Same reason that L1 / L2 / L3 caches work
- The set of virtual pages that a program is “actively” accessing at any point in time is called its *working set*
- If (working set size of one process < main memory size):
 - Good performance for one process (after compulsory misses)
- But if $\text{SUM}(\text{working set sizes of all processes}) > \text{main memory size}$:
 - *Thrashing*: Performance meltdown where pages are swapped (copied) between memory and disk continuously. CPU always waiting or paging.

Simplifying Linking and Loading

■ Linking

- Each program has similar virtual address space
- Code, data, and heap always start at the same addresses.

■ Loading

- `execve` allocates virtual pages for `.text` and `.data` sections & creates PTEs marked as invalid
- The `.text` and `.data` sections are copied, page by page, on demand by the virtual memory system

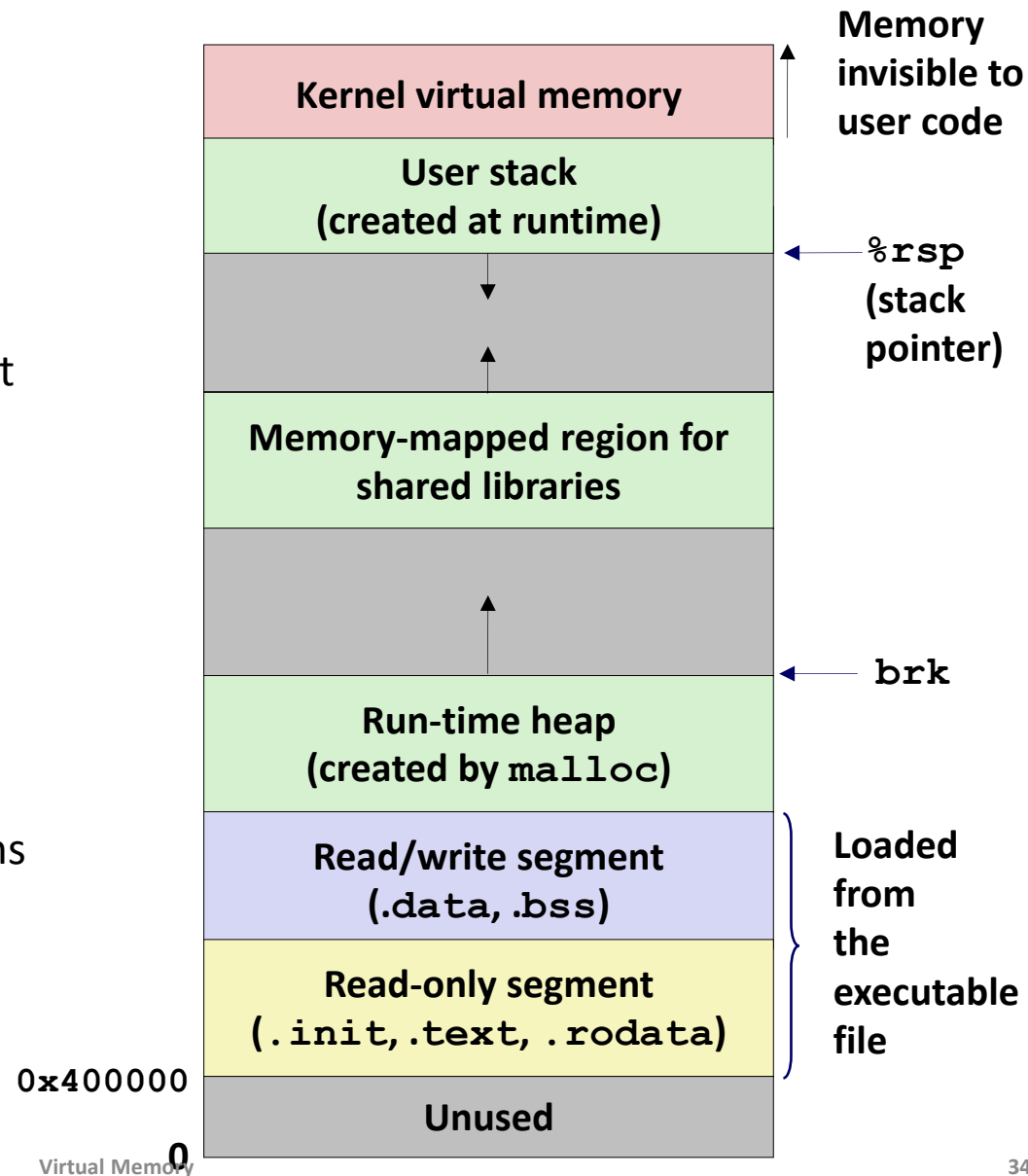

VM for Managing Multiple Processes

- **Key abstraction: each process has its own virtual address space**
 - It can view memory as *a simple linear array*
- **With virtual memory, this simple linear virtual address space **need not be contiguous in physical memory****
 - Process needs to store data in another VP? Just map it to *any* PP!

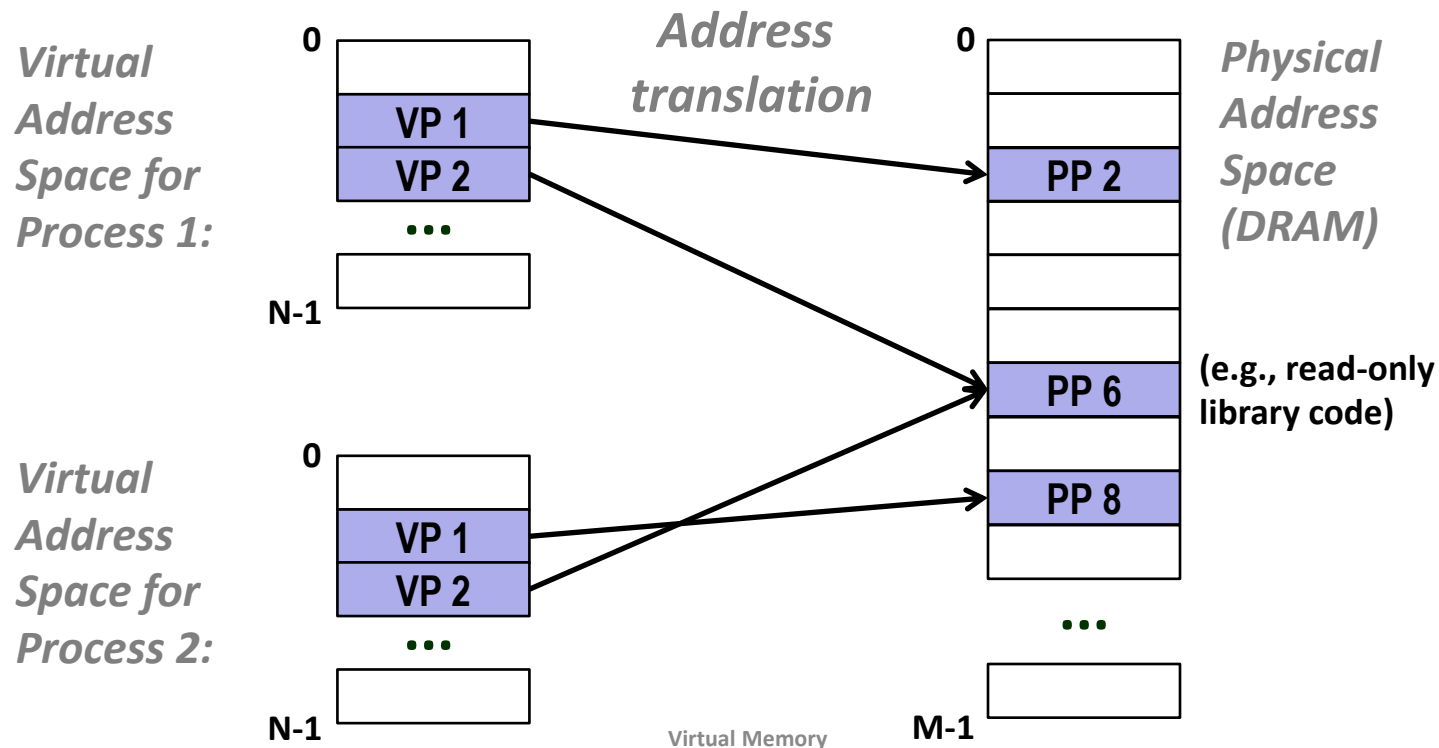

VM for Protection and Sharing

- The mapping of VPs to PPs provides a simple mechanism to *protect* memory and to *share* memory between processes.
 - **Sharing**: just map virtual pages in separate address spaces to the same physical page (here: PP 6)
 - **Protection**: process simply can't access physical pages to which none of its virtual pages are mapped (here: Process 2 can't access PP 2).

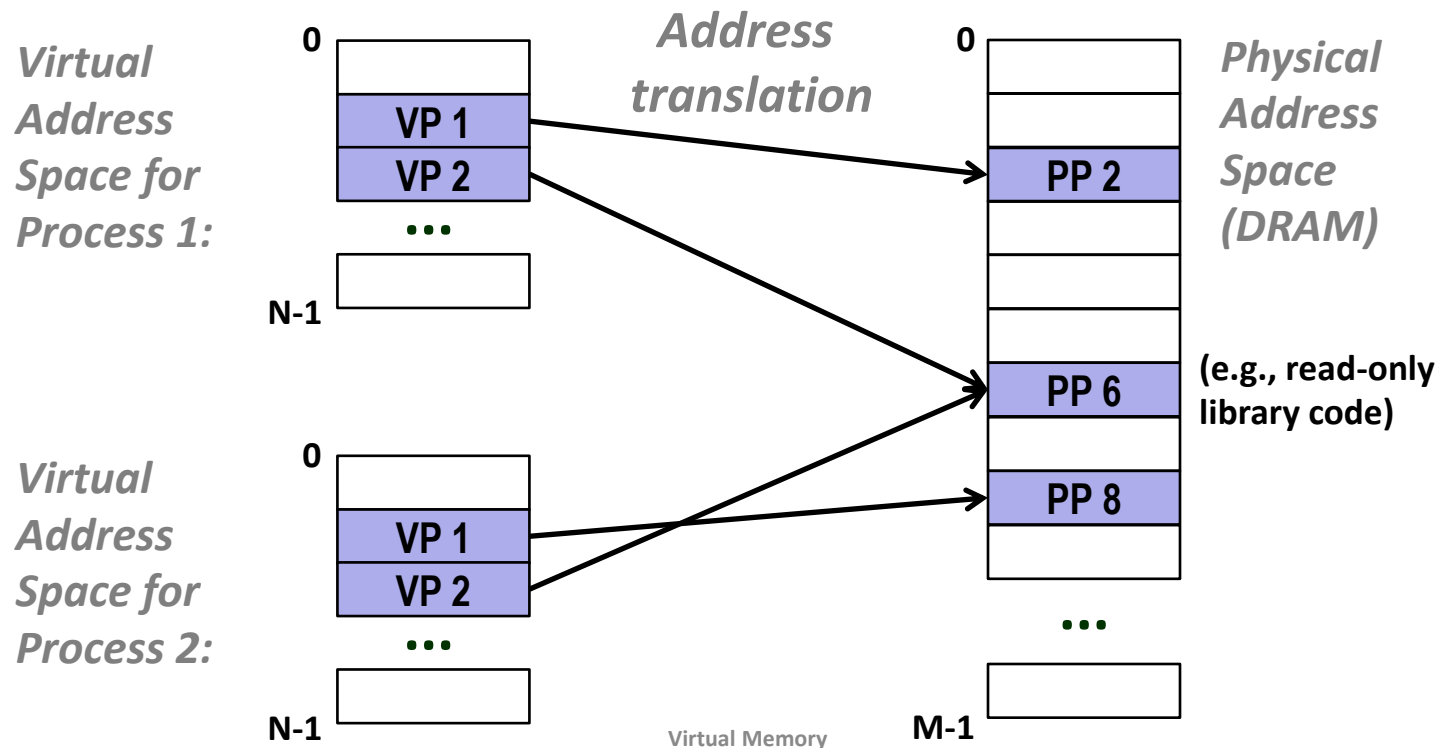

Memory Protection Within a Single Process

- Can we use virtual memory to control read/write/execute permissions? How?

Memory Protection Within a Single Process

- Extend page table entries with permission bits
- MMU checks these permission bits on every memory access
 - If violated, raises exception and OS sends SIGSEGV signal to process (segmentation fault)

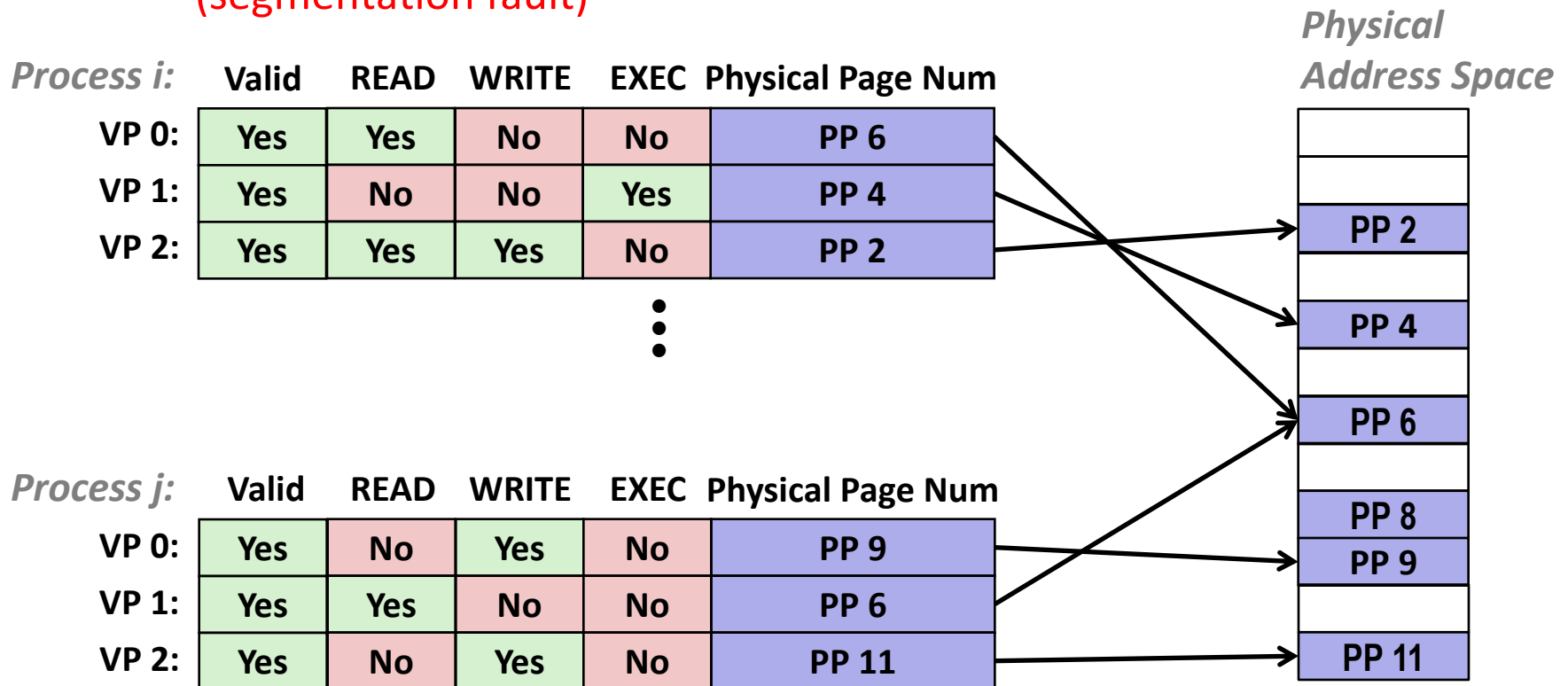

Terminology

■ context switch

- Switch between processes on the same CPU

■ page in

- Move pages of virtual memory from disk to physical memory

■ page out

- Move pages of virtual memory from physical memory to disk

■ thrash

- Total working set size of processes is larger than physical memory
- Most time is spent paging in and out instead of doing useful computation

Address Translation: Page Hit

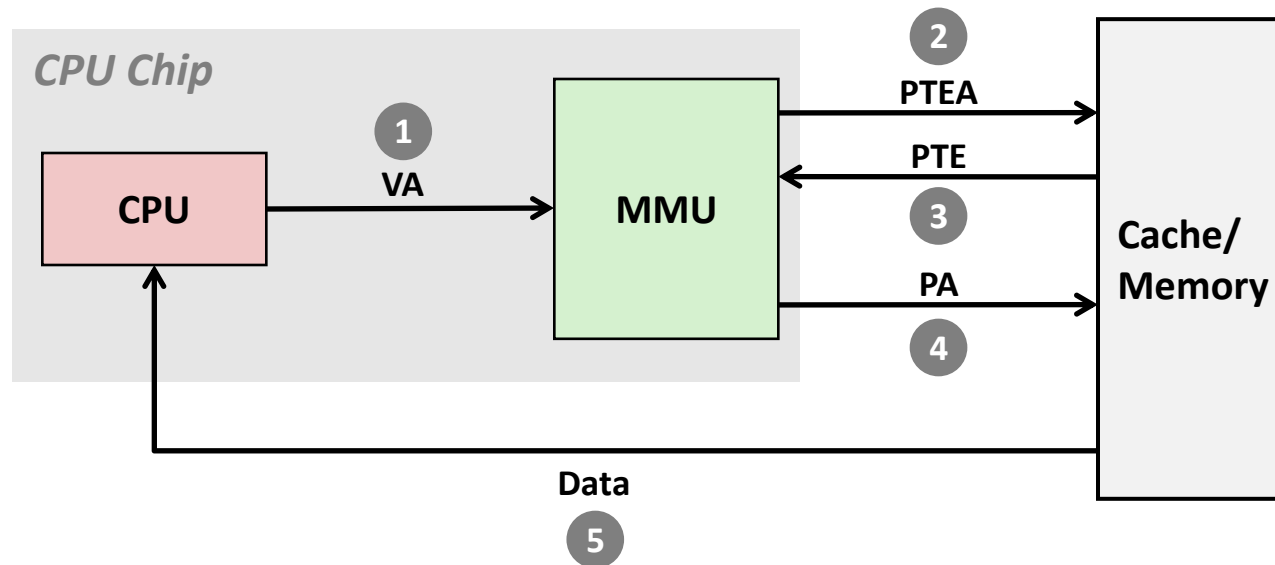

- 1) Processor sends virtual address to MMU (*memory management unit*)
- 2-3) MMU fetches PTE from page table in cache/memory
(Uses PTBR to find beginning of page table for current process)
- 4) MMU sends physical address to cache/memory
- 5) Cache/memory sends data word to processor

VA = Virtual Address
PA = Physical Address

PTEA = Page Table Entry Address
Data = Contents of memory stored at VA originally requested by CPU

PTE = Page Table Entry

Address Translation: Page Fault

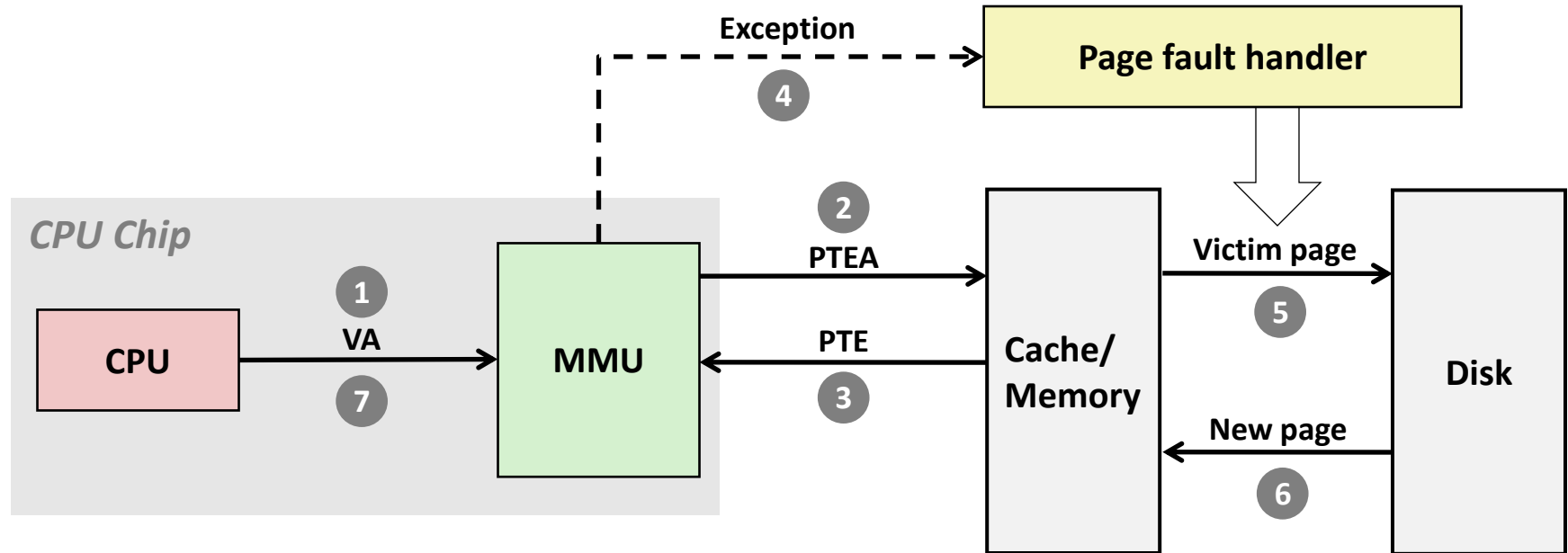

- 1) Processor sends virtual address to MMU
- 2-3) MMU fetches PTE from page table in cache/memory
- 4) Valid bit is zero, so MMU triggers page fault exception
- 5) Handler identifies victim (and, if dirty, pages it out to disk)
- 6) Handler pages in new page and updates PTE in memory
- 7) Handler returns to original process, restarting faulting instruction

Hmm... Translation Sounds Slow!

- The MMU accesses memory *twice*: once to first get the PTE for translation, and then again for the actual memory request from the CPU
 - The PTEs *may* be cached in L1 like any other memory word
 - But they may be evicted by other data references
 - And a hit in the L1 cache still requires 1-3 cycles
- *What can we do to make this faster?*

Speeding up Translation with a TLB

- **Solution: add another cache!**
- ***Translation Lookaside Buffer* (TLB):**
 - Small hardware cache in MMU
 - Maps virtual page numbers to physical page numbers
 - Contains complete *page table entries* for small number of pages
 - Modern Intel processors: 128 or 256 entries in TLB
 - Much faster than a page table lookup in cache/memory

TLB Hit

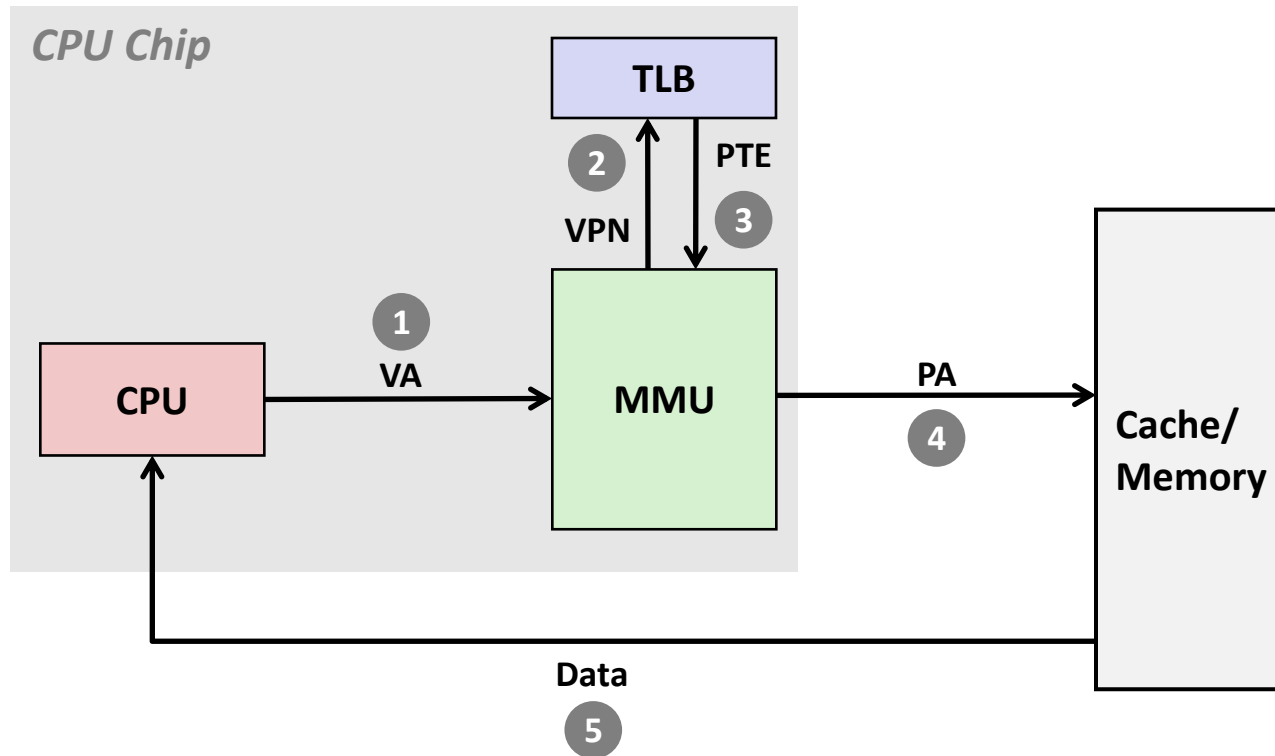

A TLB hit eliminates a memory access

TLB Miss

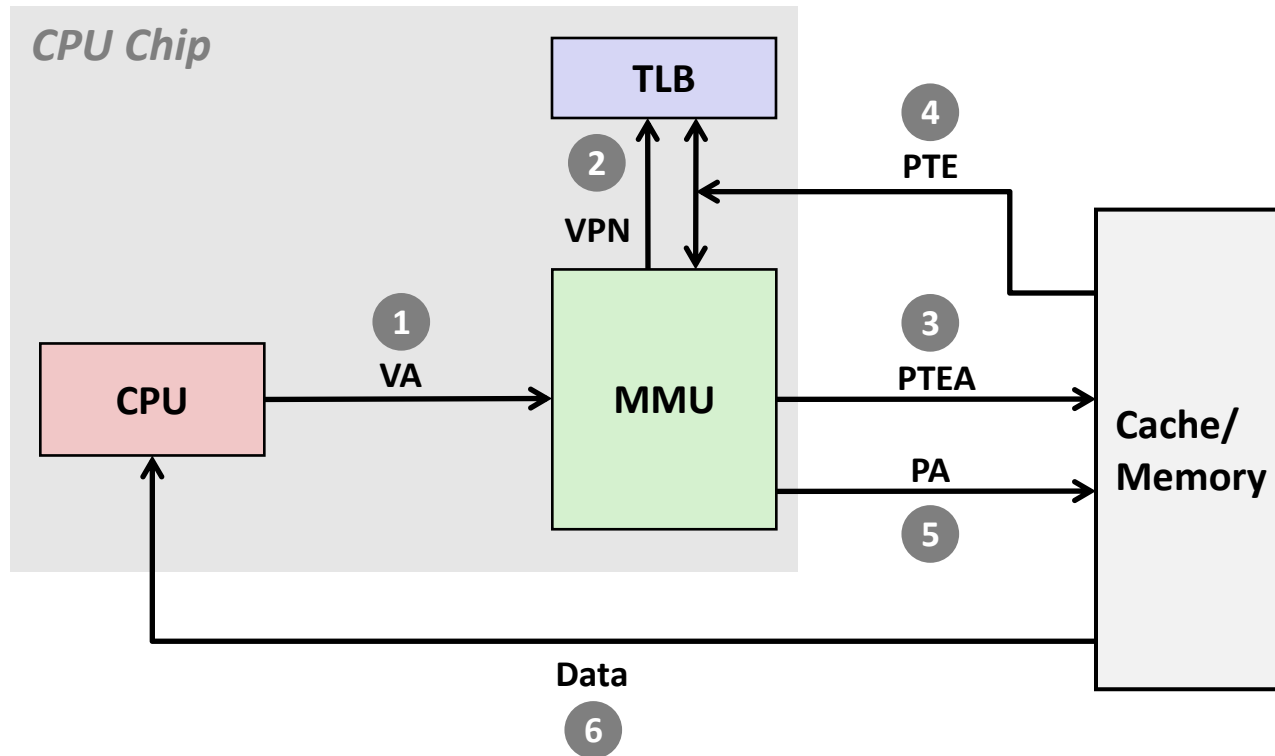

A TLB miss incurs an additional memory access (the PTE)

Fortunately, TLB misses are rare.

Summary of Address Translation Symbols

■ Basic Parameters

- $N = 2^n$: Number of addresses in virtual address space
- $M = 2^m$: Number of addresses in physical address space
- $P = 2^p$: Page size (bytes)

■ Components of the virtual address (VA)

- TLBI: TLB index
- TLBT: TLB tag
- VPO: Virtual page offset
- VPN: Virtual page number

■ Components of the physical address (PA)

- PPO: Physical page offset (same as VPO)
- PPN: Physical page number

Simple Memory System Example (small)

■ Addressing

- 14-bit virtual addresses
- 12-bit physical address
- Page size = 64 bytes

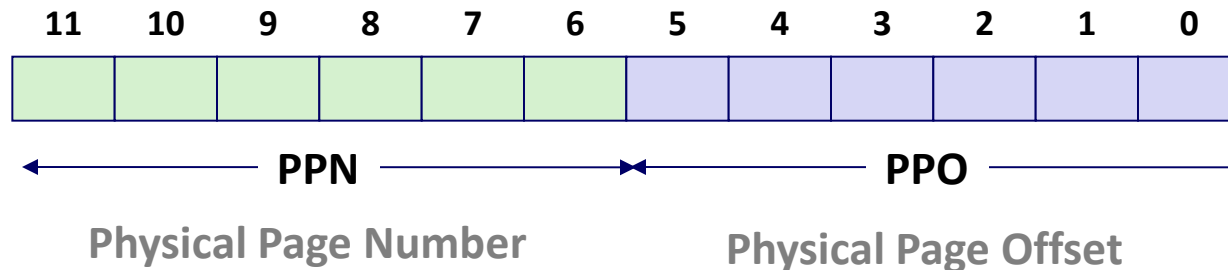
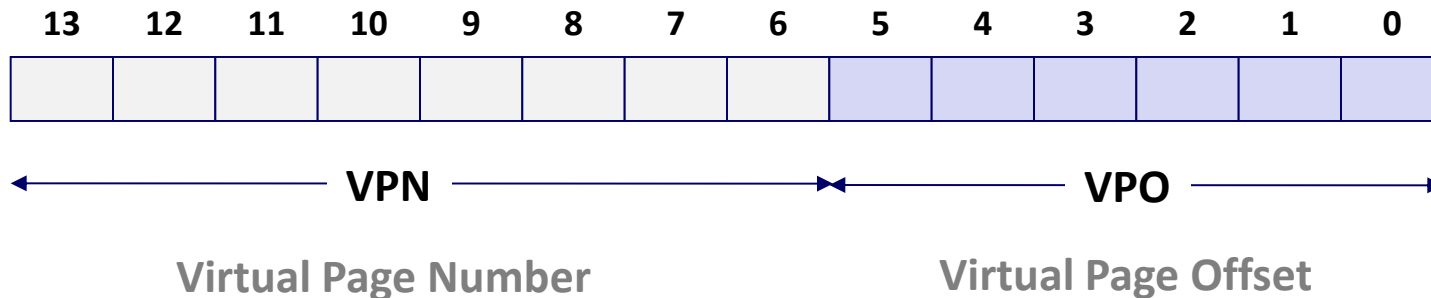

Simple Memory System Page Table

- Only showing first 16 entries (out of 256 = 2^8)

<i>VPN</i>	<i>PPN</i>	<i>Valid</i>
00	28	1
01	–	0
02	33	1
03	02	1
04	–	0
05	16	1
06	–	0
07	–	0

<i>VPN</i>	<i>PPN</i>	<i>Valid</i>
08	13	1
09	17	1
0A	09	1
0B	–	0
0C	–	0
0D	2D	1
0E	11	1
0F	0D	1

- What about a real address space? Read more in the book...

Simple Memory System TLB

- 16 entries total
- 4 sets
- 4-way associative

TLB ignores page offset. Why?

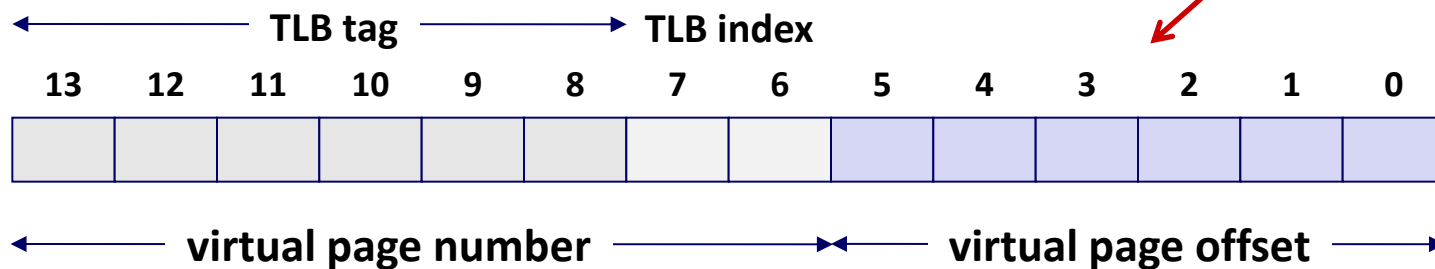

Set	Tag	PPN	Valid	Tag	PPN	Valid	Tag	PPN	Valid	Tag	PPN	Valid
0	03	–	0	09	0D	1	00	–	0	07	02	1
1	03	2D	1	02	–	0	04	–	0	0A	–	0
2	02	–	0	08	–	0	06	–	0	03	–	0
3	07	–	0	03	0D	1	0A	34	1	02	–	0

Simple Memory System Cache

Note: It is just random that the physical page number is the same bits as the cache tag

- 16 lines, 4-byte block size
- Physically addressed
- Direct mapped

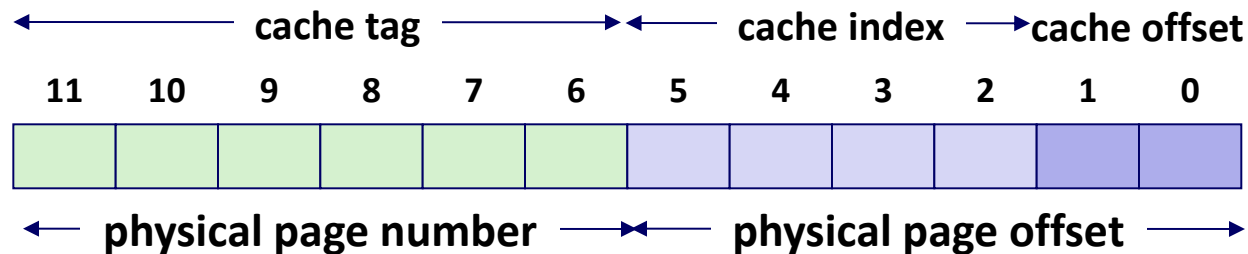

Index	Tag	Valid	B0	B1	B2	B3
0	19	1	99	11	23	11
1	15	0	–	–	–	–
2	1B	1	00	02	04	08
3	36	0	–	–	–	–
4	32	1	43	6D	8F	09
5	0D	1	36	72	F0	1D
6	31	0	–	–	–	–
7	16	1	11	C2	DF	03

Index	Tag	Valid	B0	B1	B2	B3
8	24	1	3A	00	51	89
9	2D	0	–	–	–	–
A	2D	1	93	15	DA	3B
B	0B	0	–	–	–	–
C	12	0	–	–	–	–
D	16	1	04	96	34	15
E	13	1	83	77	1B	D3
F	14	0	–	–	–	–

Current state of caches/tables

Page table (partial)

TLB

Set	Tag	PPN	Valid	Tag	PPN	Valid	Tag	PPN	Valid	Tag	PPN	Valid
0	03	–	0	09	0D	1	00	–	0	07	02	1
1	03	2D	1	02	–	0	04	–	0	0A	–	0
2	02	–	0	08	–	0	06	–	0	03	–	0
3	07	–	0	03	0D	1	0A	34	1	02	–	0

VPN	PPN	Valid	VPN	PPN	Valid
00	28	1	08	13	1
01	–	0	09	17	1
02	33	1	0A	09	1
03	02	1	0B	–	0
04	–	0	0C	–	0
05	16	1	0D	2D	1
06	–	0	0E	11	1
07	–	0	0F	0D	1

Cache

Index	Tag	Valid	B0	B1	B2	B3
0	19	1	99	11	23	11
1	15	0	–	–	–	–
2	1B	1	00	02	04	08
3	36	0	–	–	–	–
4	32	1	43	6D	8F	09
5	0D	1	36	72	F0	1D
6	31	0	–	–	–	–
7	16	1	11	C2	DF	03

Index	Tag	Valid	B0	B1	B2	B3
8	24	1	3A	00	51	89
9	2D	0	–	–	–	–
A	2D	1	93	15	DA	3B
B	0B	0	–	–	–	–
C	12	0	–	–	–	–
D	16	1	04	96	34	15
E	13	1	83	77	1B	D3
F	14	0	–	–	–	–

Address Translation Example #1

Virtual Address: 0x03D4

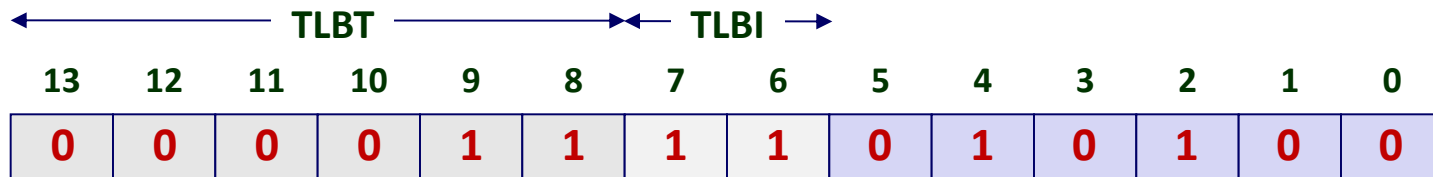

VPN ___ TLBI ___ TLBT _____ TLB Hit? ___ Page Fault? ___ PPN: _____

Physical Address

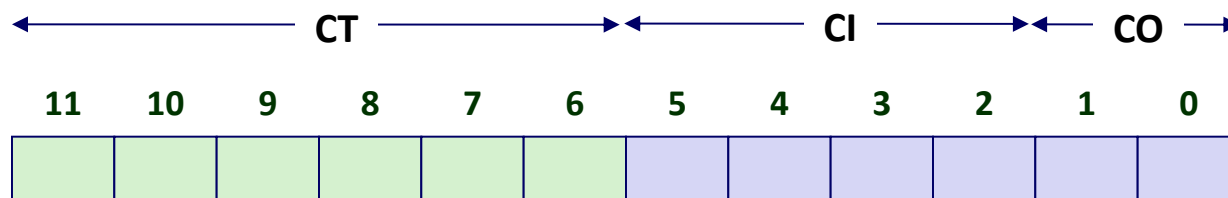

CO ___ CI ___ CT _____ Hit? ___ Byte: _____

Address Translation Example #1

Virtual Address: 0x03D4

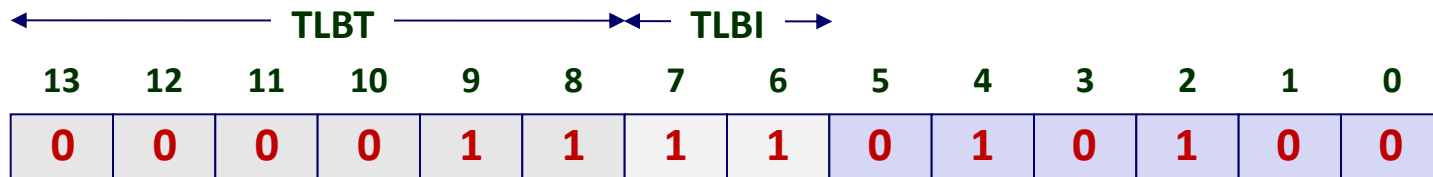

VPN 0x0F TLBI 3 TLBT 0x03 TLB Hit? Y Page Fault? N PPN: 0x0D

Physical Address

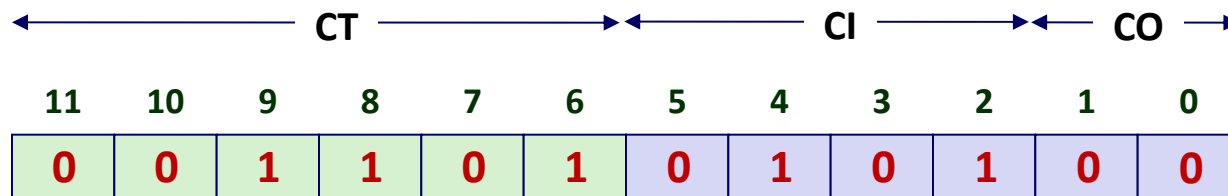

CO 0 CI 0x5 CT 0x0D Hit? Y Byte: 0x36

Address Translation Example #2

Virtual Address: 0x0B8F

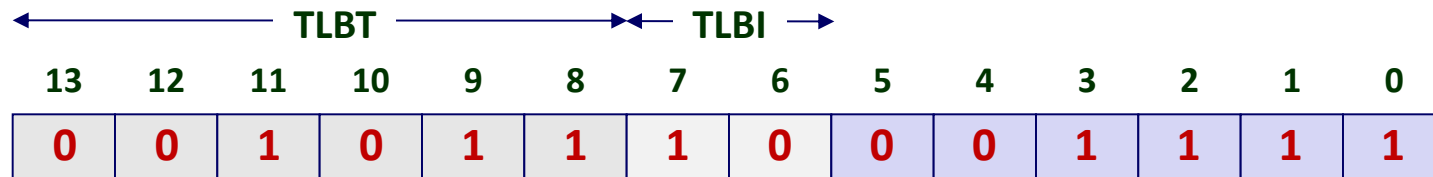

VPN ___ TLBI ___ TLBT ___ TLB Hit? ___ Page Fault? ___ PPN: ___

Physical Address

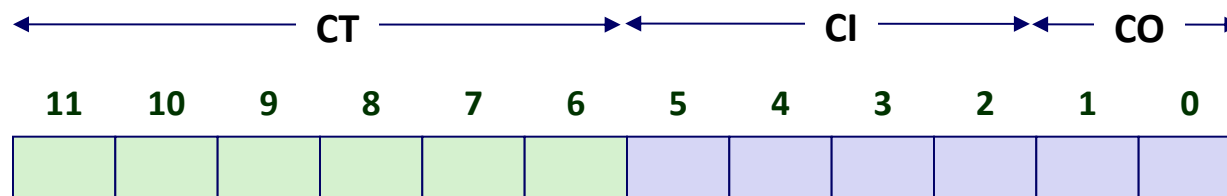

CO ___ CI ___ CT ___ Hit? ___ Byte: ___

Address Translation Example #2

Virtual Address: 0x0B8F

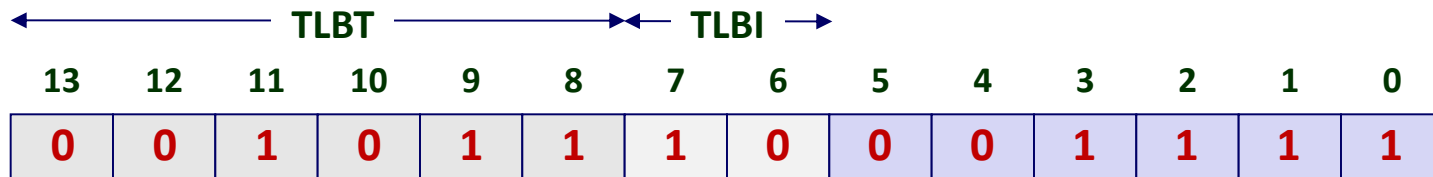

VPN 0x2E TLBI 2 TLBT 0x0B TLB Hit? N Page Fault? ? PPN: TBD

Physical Address

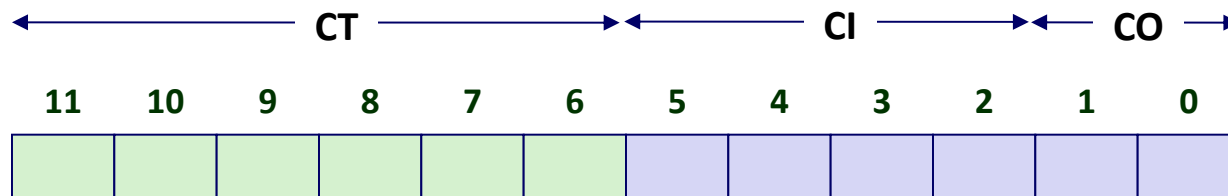

CO CI CT Hit? Byte:

Address Translation Example #3

Virtual Address: 0x0020

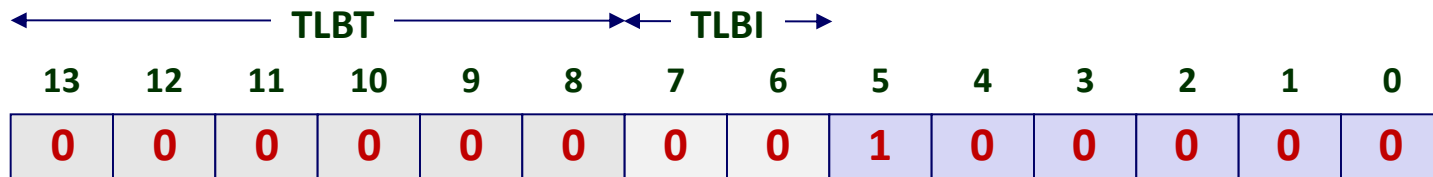

VPN ___ TLBI ___ TLBT ___ TLB Hit? ___ Page Fault? ___ PPN: ___

Physical Address

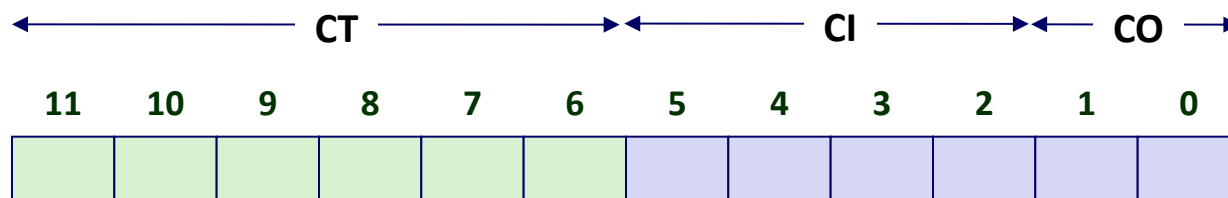

CO ___ CI ___ CT ___ Hit? ___ Byte: ___

Address Translation Example #3

Virtual Address: 0x0020

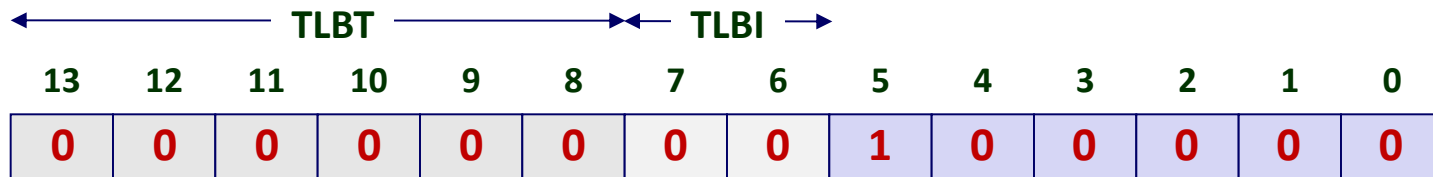

VPN 0x00 TLBI 0 TLBT 0x00 TLB Hit? N Page Fault? N PPN: 0x28

Physical Address

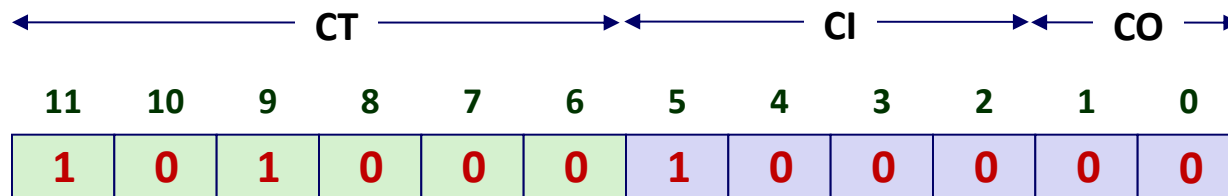

CO 0 CI 0x8 CT 0x28 Hit? N Byte: Mem

Address Translation Example #4

Virtual Address: 0x036B

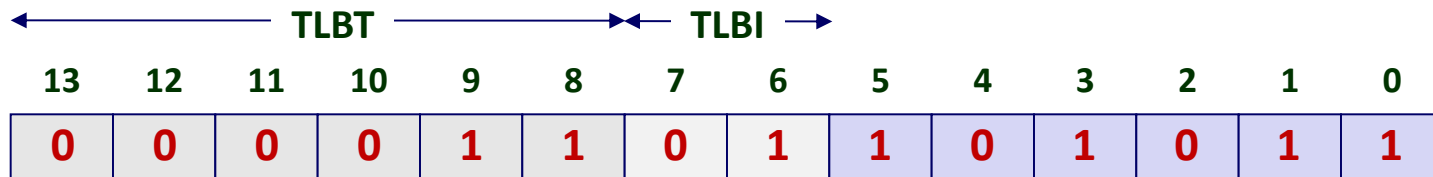

VPN ___ TLBI ___ TLBT ___ TLB Hit? ___ Page Fault? ___ PPN: ___

Physical Address

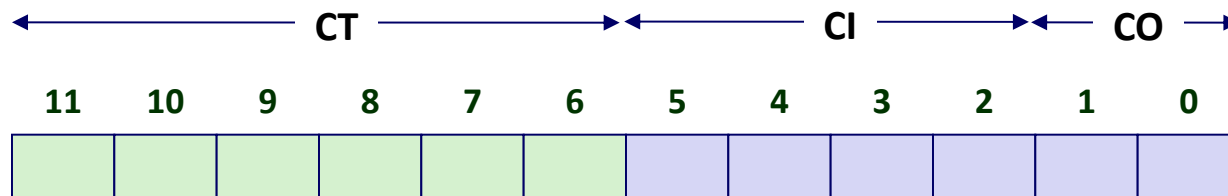

CO ___ CI ___ CT ___ Hit? ___ Byte: ___

Address Translation Example #4

Virtual Address: 0x036B

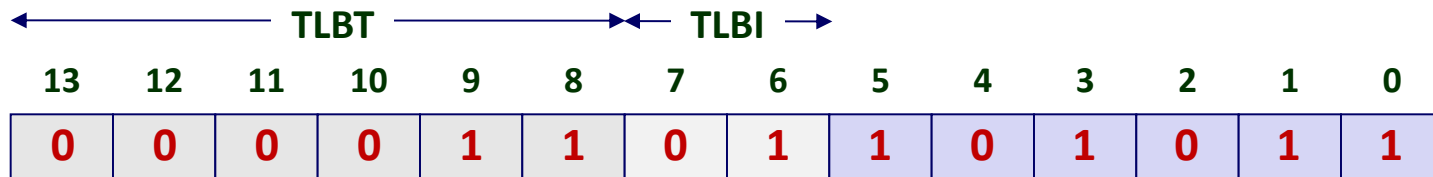

VPN 0x0D TLBI 1 TLBT 0x03 TLB Hit? Y Page Fault? N PPN: 0x2D

Physical Address

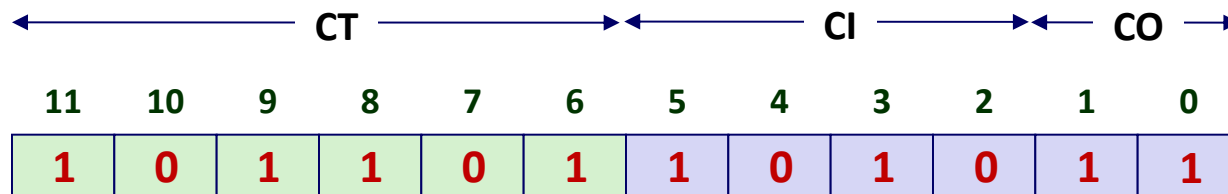

CO 3 CI 0xA CT 0x2D Hit? Y Byte: 0x3B

Summary

■ Programmer's view of virtual memory

- Each process has its own private linear address space
- Cannot be corrupted by other processes

■ System view of virtual memory

- Uses memory efficiently by caching virtual memory pages
 - Efficient only because of locality
- Simplifies memory management and sharing
- Simplifies protection by providing a convenient interpositioning point to check permissions

Memory System Summary

■ L1/L2 Memory Cache

- Purely a speed-up technique
- Behavior invisible to application programmer and (mostly) OS
- Implemented totally in hardware

■ Virtual Memory

- Supports many OS-related functions
 - Process creation, task switching, protection
- Operating System (software)
 - Allocates/shares physical memory among processes
 - Maintains high-level tables tracking memory type, source, sharing
 - Handles exceptions, fills in hardware-defined mapping tables
- Hardware
 - Translates virtual addresses via mapping tables, enforcing permissions
 - Accelerates mapping via translation cache (TLB)

Memory System – Who controls what?

■ L1/L2 Memory Cache

- Controlled by hardware
- Programmer cannot control it
- Programmer *can* write code in a way that takes advantage of it

■ Virtual Memory

- Controlled by OS and hardware
- Programmer cannot control mapping to physical memory
- Programmer can control sharing and some protection
 - via OS functions (not in CSE 351)

Quick Review

- What do Page Tables Map?
- Where are Page Tables?
- How many Page Tables are there?
- Can your program tell if a page fault has occurred?
- What is thrashing?
- T/F Virtual Addresses that are contiguous will always be contiguous in physical memory.
- TLB stands for _____ and stores _____

Quick Review Answers

- **What do Page Tables Map?**
 - Virtual pages to physical pages or location on disk
- **Where are Page Tables?**
 - In physical memory
- **How many Page Tables are there?**
 - One per process
- **Can your program tell if a page fault has occurred?**
 - Nope. But it has to wait a long time.
- **What is thrashing?**
 - Constantly paging out and paging in. The working set of all applications you are trying to run is bigger than physical memory.
- **T/F Virtual Addresses that are contiguous will always be contiguous in physical memory. (could be on different physical pages)**
- **TLB stands for Translation lookaside buffer, and stores page table entries**