

# CSE 333

## Section 10

Future Classes, and Wrap-up

# Logistics

- **HW4**

- Due **Thursday @ 11:00 pm (Tonight!!)**
  - Up to 2 late days allowed if you still have them

- **Final Exam**

- **Review Session** in ECE 105 on Tuesday (3/11) @ **4:30pm**
  - Bring questions!
- **Exam Tuesday (3/12) @ 12:30 pm**

# Homework Summary

# Homework Summary

**Homework 1:** Implemented a Doubly-Linked List and a Chained Hash Table

**Homework 2:** Created a local search engine (like grep)

**Homework 3:** Modified HW2 to save and read index files from disk

**Homework 4:** Creating an internet-accessible version of your search engine!

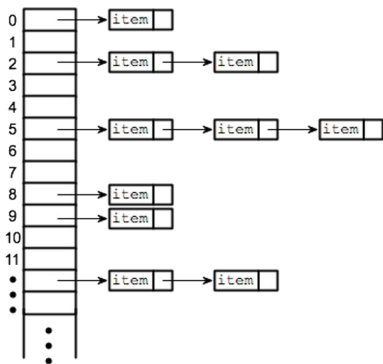

```
[attul hw2]$ ./searchshell ./test_tree
Indexing './test_tree'
enter query:
ulysses
./test_tree/books/ulysses.txt (10)
./test_tree/books/countofmontecristo.txt (2)
./test_tree/books/leavesofgrass.txt (1)
./test_tree/books/lesmiserables.txt (1)
./test_tree/books/paradiselost.txt (1)
enter query:
```



# Reflection Activity

Take about 5 minutes with yourself and your neighbors to reflect on your experiences with homework, exercises, and lecture this quarter.

Guiding Questions:

- What were a few things that you took away from this course?
- What are a few things that you are still confused about?
- What were the most interesting topics to you this quarter?
- What advice would you give to a future CSE 333 student?

# Outcomes of Doing the Homework

- Building a sample system based on the design decisions the staff has made for the homeworks
  - You can consider why these decisions were made
- Getting accustomed to larger-scale programming projects
  - Learning about the code surrounding what you are to implement
- Practicing programming idioms – error checking, style guides, etc.
- Reading Documentation!

# Adding it to your Resume

- Why consider adding it in?
  - You had to work with this code base for an entire quarter
  - It demonstrates your ability to work with a large code base and system
  - It's pretty cool to add "mini-Google" in
- What might be on there?
  - **System Design** – Creating data structures to store information. Saving it into a file.  
Following a protocol to create a web application
  - Programming in C and C++ (handling C/C++ idioms)

# What's Next?



# Main Course Themes



- Debugging: gdb, valgrind, and... rubber duckies
  - Solving Seg. Faults, Memory Leaks, incorrect output
  - C/C++ programming hopefully made you more cognizant of where bugs may occur at a low level
- Program Layout: Modularity, Helper functions, Inheritance
  - Improve readability and ease of maintenance
- Documentation: Reading API's and incorporating into programs
  - C++ Reference Guide, man pages
- Google Style Guide: linter, Lots of reading...
  - cplint.py is an automated tool to help with catching style issues
  - A lot of it was learning to adapt to a system for writing and reading code in the same format

# CSE 451 – Operating Systems

- CSE333 is called “Systems Programming”
  - We hope you learned to interact with the OS
  - “Magic OS stuff” kept mostly hidden in CSE 333
- If you want to understand the “magic OS” stuff, take this!
- Usually in C 😊
- Partner class!
- Lots of work, but very rewarding!

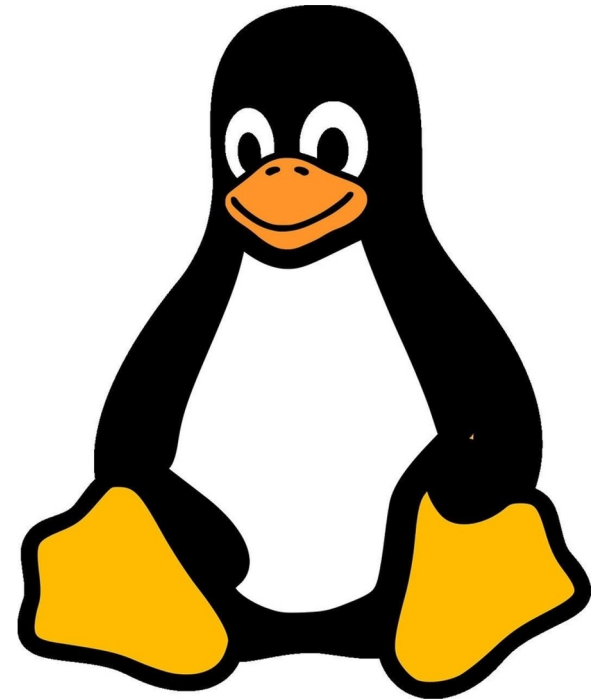

# CSE 452 – Distributed Systems

- Understanding how to design massive, fault tolerant systems over an unreliable network.
  - Think Facebook, AWS, Google, etc.
- Doesn't require OS, topics rarely if at all come up
- More theory to it than you'd think
- Lots of work (project is big and confusing)
- Most thought per line of code of any class in the Allen School, also many lines of code
- Hard, but very very cool. Would strongly recommend. Huge resume booster.

# CSE 461 - Networks

- We did a “basic” understanding of how networks work
- We mainly just understood how it works in C and with POSIX
- Mostly Python
  - First lab is “language of choice”

- Teams/Group Work

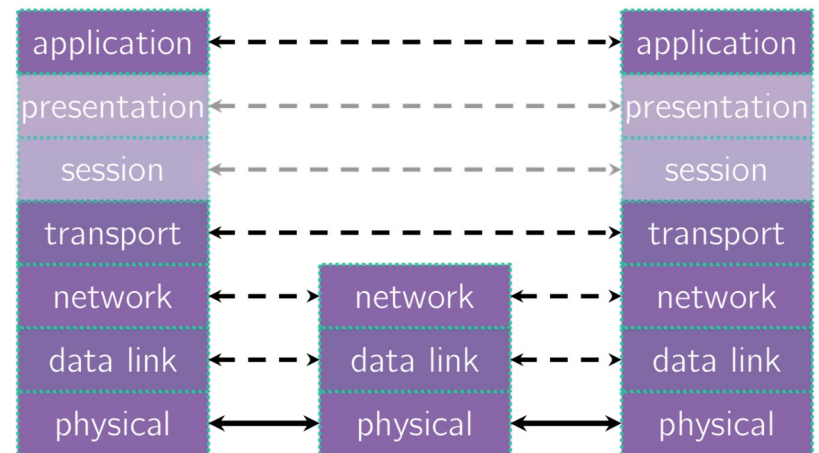

# CSE 457 - Graphics

- Cool, but hard
- Lots of C/C++, some linear algebra & physics
- If you want to do graphics, you have to do it in C++
- You will make cool artifacts in this course!
- Skeleton code provided is not documented well and a little bit “spaghetti” 😞

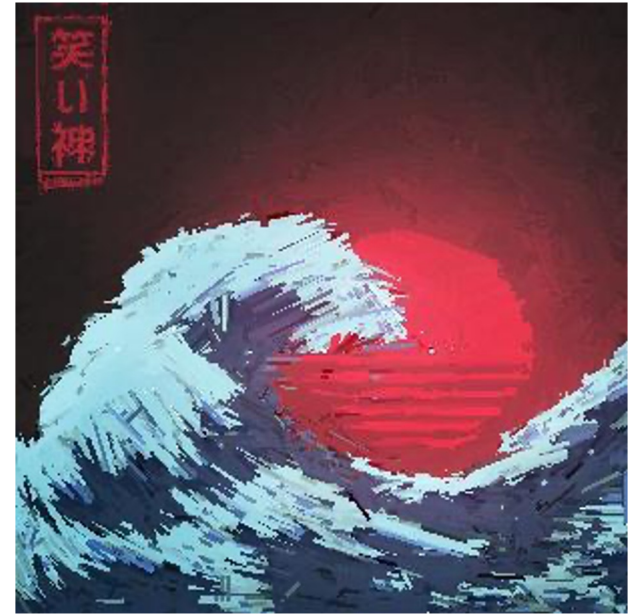

# CSE 455 – Computer Vision

- Deals with bytes in an image
  - This part is in C 😊
- Deals with ML
  - “New ways” to do computer vision via ML
- Sometimes, these are the people making attu slow 😞



# Shoutout: Other Classes

- How about that “mysterious” compiler? 401 Compilers
- Liked HTML (for some reason)? 154 Web Dev
- Want to do C on limited systems? 474 Embedded Systems
- Learn about more low-level stuff? 369 & 371 Digital Design
- Want to learn about CPU magic? 469 & 470 Comp Arch
- Liked patching up your 333gle? ssh-keys? 484 Security

# TA-ing

- You are all well enough equipped to TA CSE333, CSE351, CSE374 and others.
- You do NOT have to 4.0 a class to TA it
- You do NOT have to be a super social person to TA  
(Some of us are very introverted)
- TAing will reinforce your understanding of any material
- **TAs are human too. It is okay to start off imperfect and make mistakes**
- **If you think you would be interested, we would highly recommend reaching out and giving it a try. Please feel free to talk to us if you are interested!**



**Ask us Anything!!**



# Before We Go...

This quarter has been tough!

This section wouldn't have been the same without all of you!

We were glad to have you! You earned your place here, you belong here (on this campus, in this program, in this course)

You know the content, take it slow, you can do it!

# You've Learned A Lot! Good Luck!



**Thank You for a Great Quarter!**