



[pollev.com/cse333](https://pollev.com/cse333)

# What would you value/prioritize if you were building a networking system?

- ❖ Open-ended word cloud!
- ❖ Networking system: a system to handle the transfer of information from one location to another

# Networks Introduction

CSE 333 Summer 2023

**Instructor:** Timmy Yang

**Teaching Assistants:**

Jennifer Xu

Leanna Nguyen

Pedro Amarante

Sara Deutscher

Tanmay Shah

# Relevant Course Information

- ❖ Exercise 9 is due Monday (7/31)
- ❖ Homework 3 is due next Thursday (8/03)
  - Debug using small custom test directories
  - Make use of the solution binaries to double-check your work
- ❖ Rest of the quarter: networking, concurrency, processes

# Lecture Outline

- ❖ Introduction to Networks
  - Layers upon layers upon layers...



more awesome pictures at [THEMETAPICTURE.COM](http://THEMETAPICTURE.COM)

# Today's Goals

- ❖ Networking is a very common programming feature
  - You will likely have to create a program that will read/write over the network at some point in your career
- ❖ We want to give you a basic, high-level understanding of how networks work before you use them
  - Lecture will be more “story-like;” we will purposefully skip over most of the details, but hopefully you will learn something new about the Internet today!
  - Take CSE 461 if you want to know more about the implementations of networks (the course is pretty cool 😊)
- ❖ Let's also examine “the network” as a *system* 
  - Inputs? Outputs? Robustness? Efficiency? Customers?

# Networks From 10,000 ft

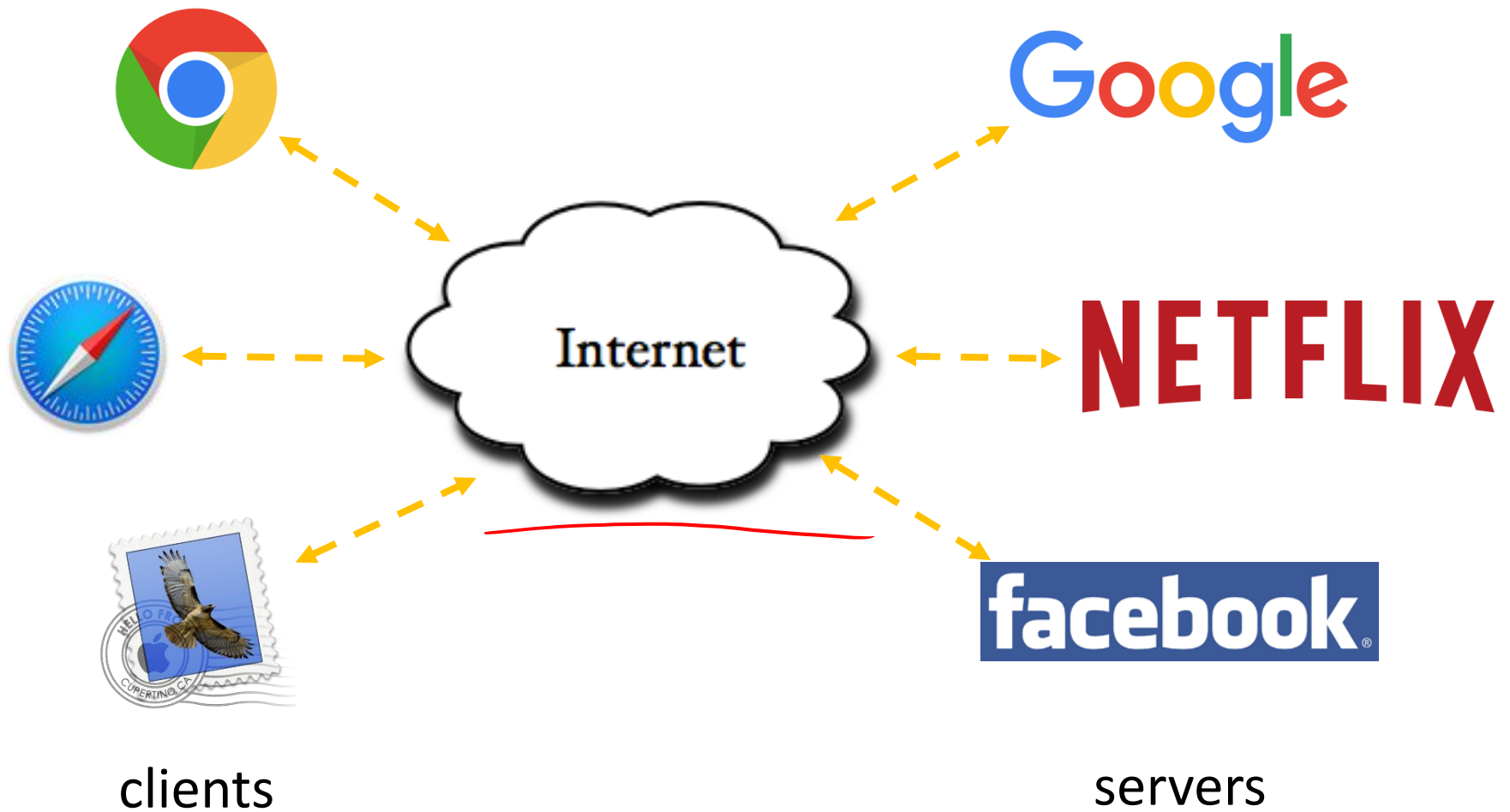

# “Network” Latency is Highly Variable

- ❖ Jeff Dean’s “Numbers Everyone Should Know” (LADIS ‘09)

L1 cache reference	0.5 ns
Branch mispredict	5 ns
L2 cache reference	7 ns
Mutex lock/unlock	100 ns
Main memory reference	100 ns
Compress 1K bytes with Zippy	10,000 ns
Send 2K bytes over 1 Gbps network	20,000 ns
Read 1 MB sequentially from memory	250,000 ns
Round trip within same datacenter	500,000 ns
Disk seek	10,000,000 ns
Read 1 MB sequentially from network	10,000,000 ns
Read 1 MB sequentially from disk	30,000,000 ns
Send packet CA->Netherlands->CA	150,000,000 ns

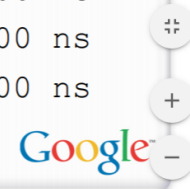
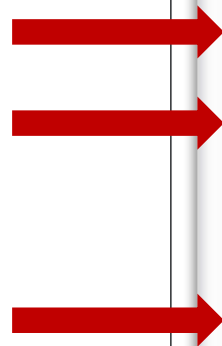

# The Physical Layer

- ❖ Individual bits are modulated onto a wire or transmitted over radio
  - Physical layer specifies how bits are encoded at a signal level
  - Many choices, *e.g.*, encode “1” as +1v, “0” as -0v; or “0”=+1v, “1”=-1v, ...

0 1 0 1

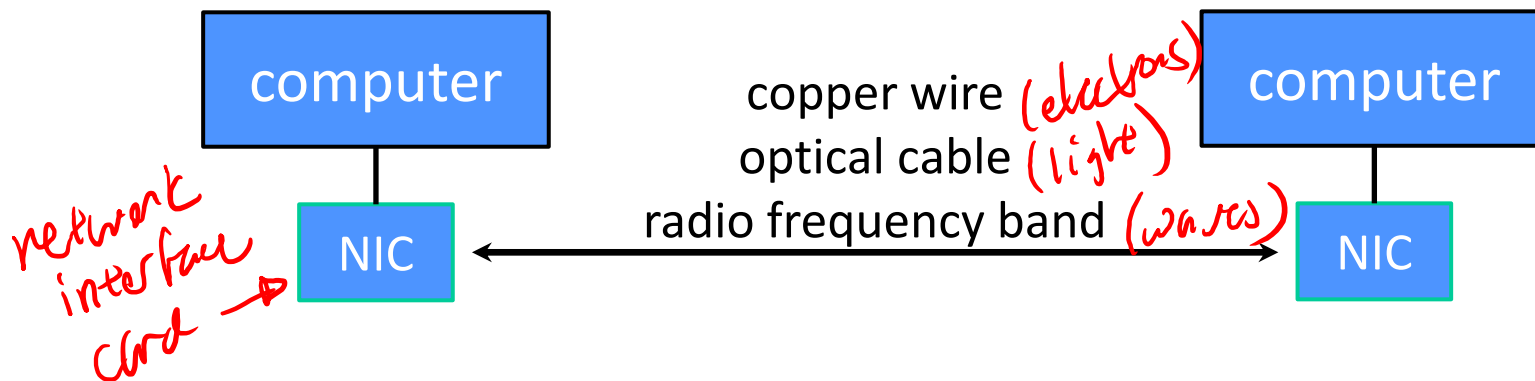
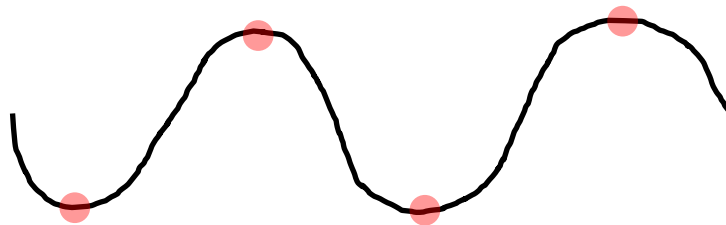





# Materials Matter – Latency

- ❖ Fiber optic cables are lower-latency and higher-bandwidth than traditional copper wiring
  - Much of the internet's "long haul" data is transmitted on these
  - (signal attenuation is much better too)
- ❖ Is it faster to send 1 person from UW to ...
  - Downtown Seattle?
  - Ballard?

# The Data Link Layer

*- Local Area Network*

- ❖ Multiple computers on a LAN contend for the network medium
  - Media access control (MAC) specifies how computers cooperate
  - Link layer also specifies how bits are “packetized” and network interface controllers (NICs) are addressed

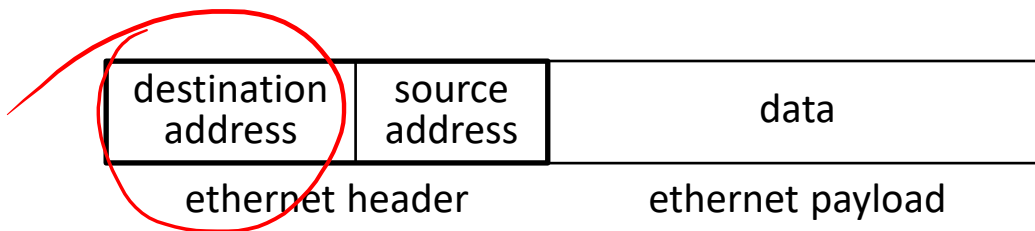
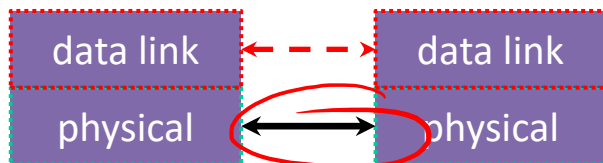
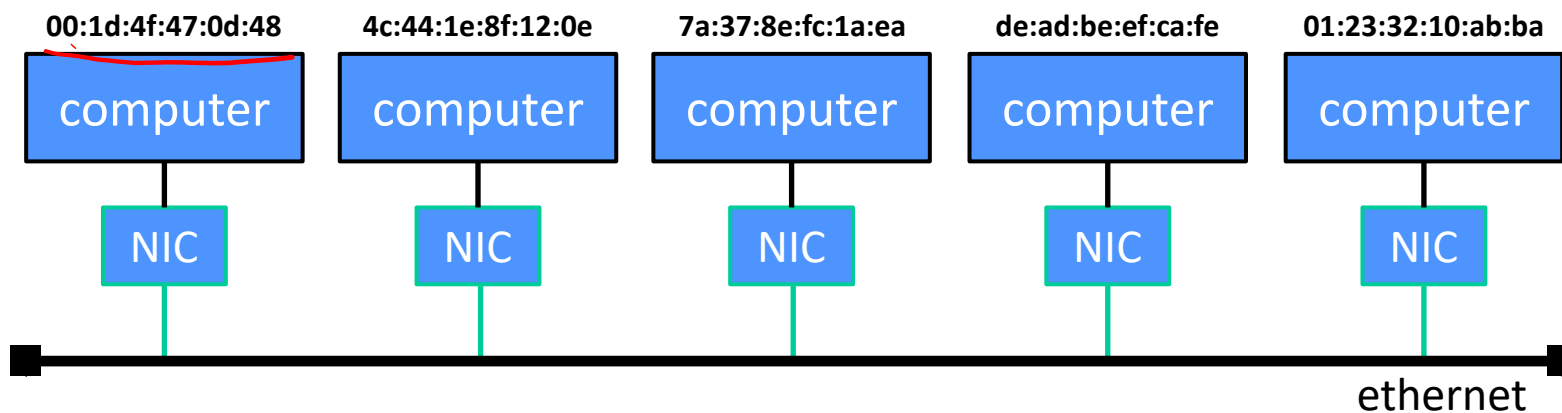

# The Network Layer (IP)

- ❖ Internet Protocol (IP) routes packets across multiple networks
  - Every computer has a unique IP address
  - Individual networks are connected by routers that span networks

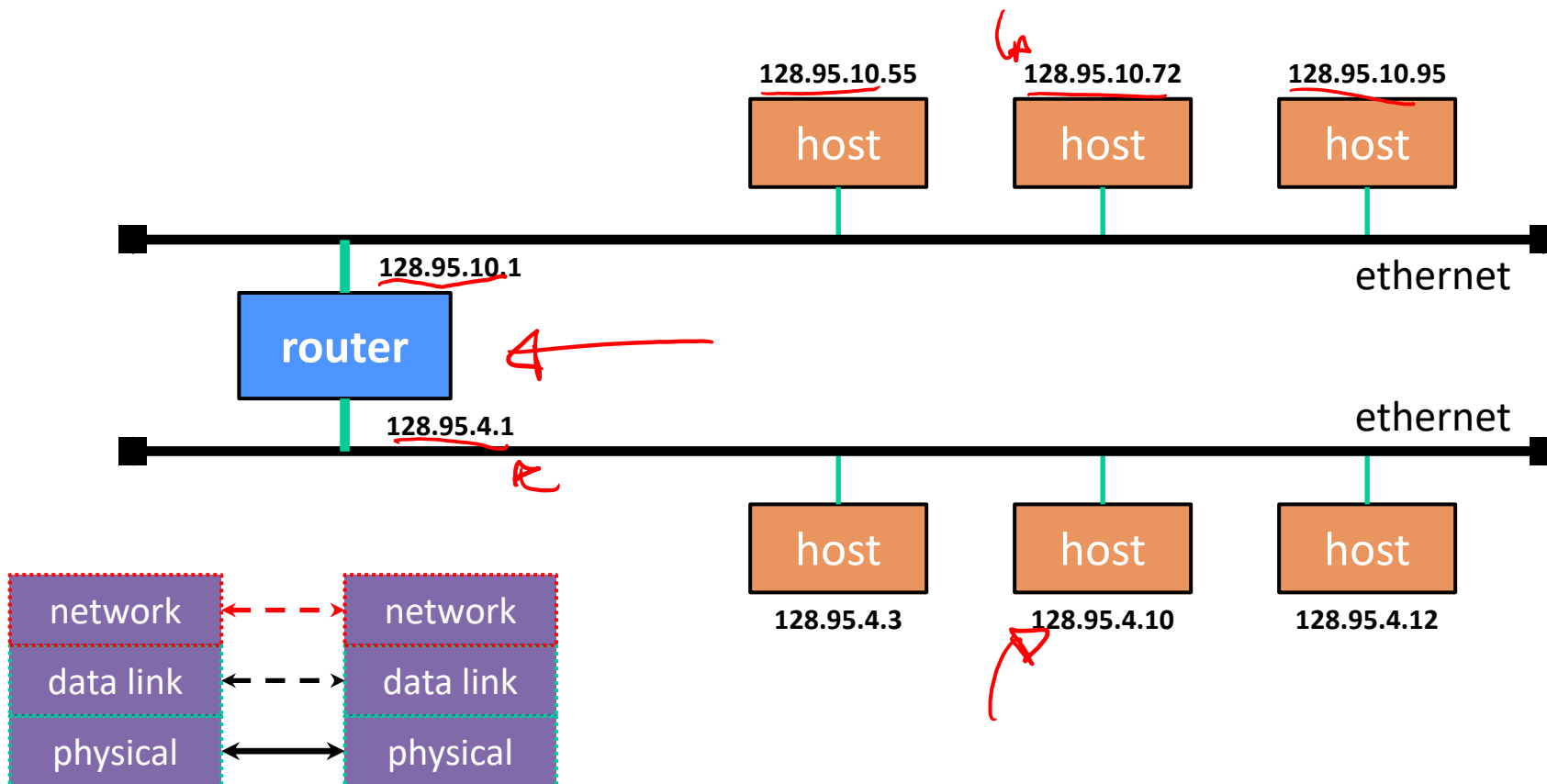

# The Network Layer (IP)

- ❖ There are protocols to:
  - Let a host map an IP to MAC address on the same network
  - Let a router learn about other routers to get IP packets one step closer to their destination

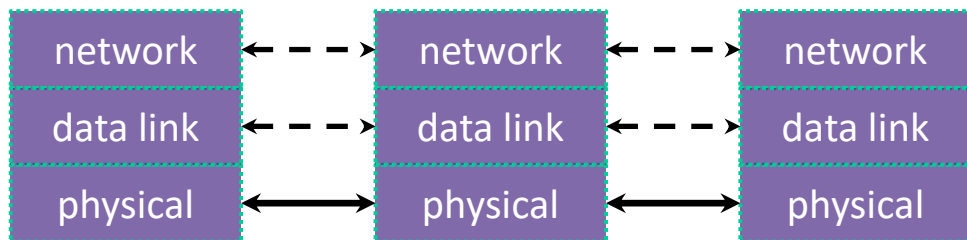
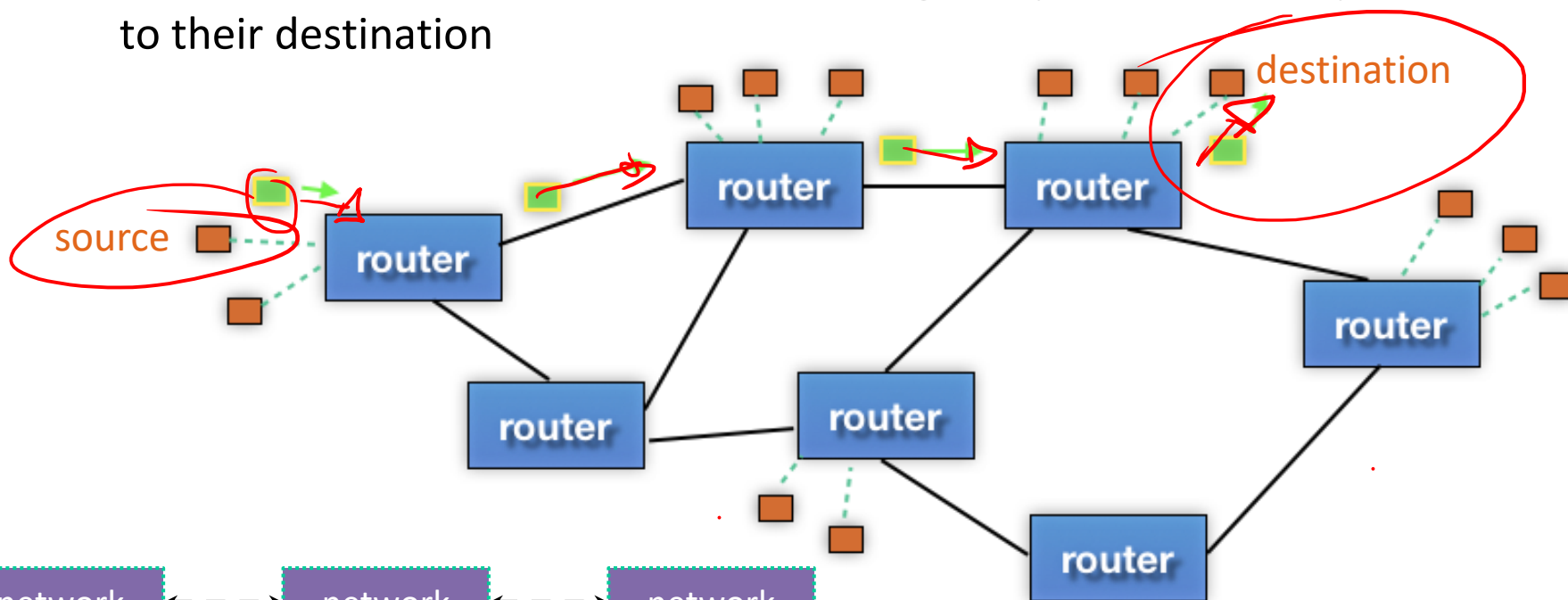

# The Network Layer (IP)

- ❖ Packet encapsulation:
  - An IP packet is encapsulated as the payload of an Ethernet frame
  - As IP packets traverse networks, routers pull out the IP packet from an Ethernet frame and plunk it into a new one on the next network

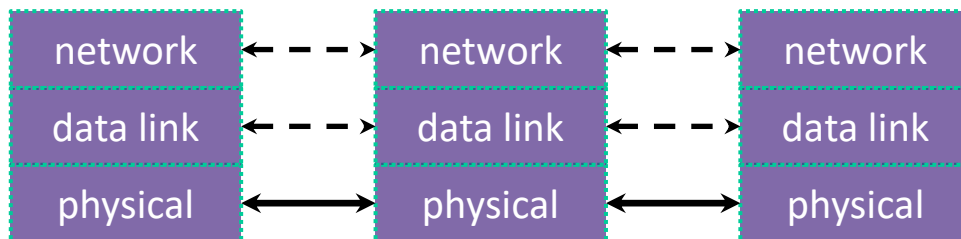
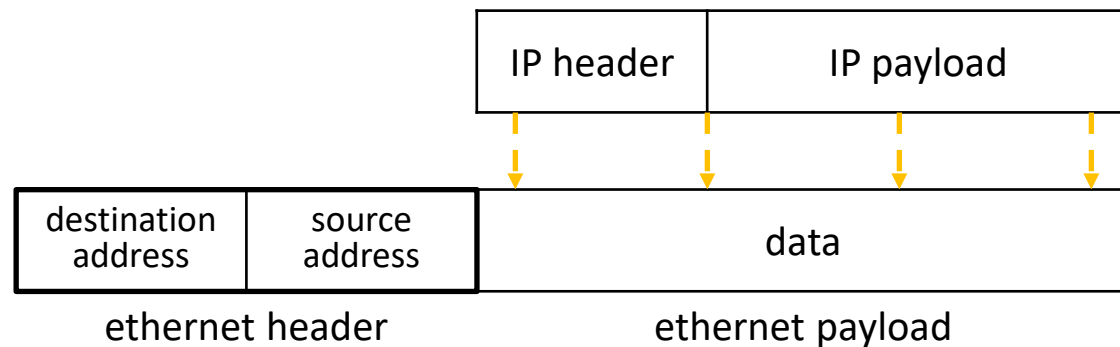



# Distance Matters – Latency

- ❖ Distances within a single datacenter are smaller than distances across continents
- ❖ Even within a datacenter, distances can sometimes matter



123Net Data Center, Wikimedia

# Topology Matters – Latency, Reliability



- ❖ Some places are surprisingly well- or poorly-connected to “backbone” infrastructure like fiber optic cables
- ❖ Unintuitive topology can create interesting failures
  - *e.g.*, 2006 7.0-magnitude Hengchun Earthquake disrupted communications to Singapore, Philippines, Thailand, China, etc. for a month

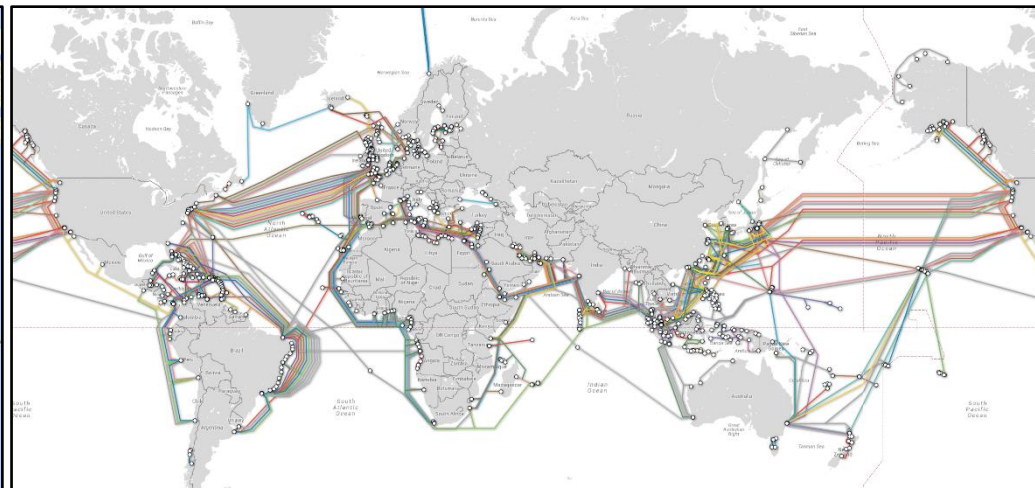



# Reflect and Discuss

- ❖ Does this system of submarine cable connections seem ‘optimal’ to you?
- ❖ If not, who influences the decision-making process and what might their motivations be?
  - Explore the map here: <https://www.submarinecablemap.com/>

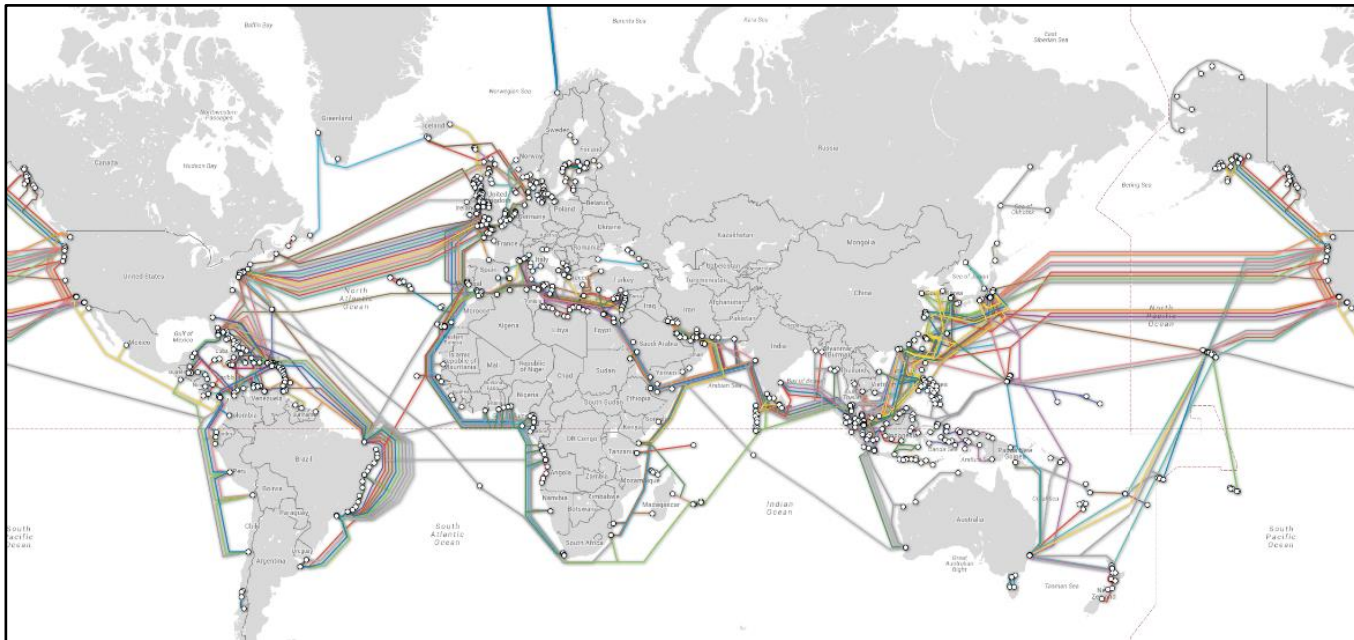





# Submarine Cable Network Today

- ❖ ~436 fiber optic cables currently in use
  - Supports 99% of transoceanic communication
  - Primarily laid during early 2000's "fiber boom", but still occasional new cables and decommissioned cables
- ❖ Owners
  - Telecom carriers
  - Content providers
- ❖ Users
  - You and many others...
- ❖ Explore the network and its history:  
<http://www.surfacing.in>

# The Transport Layer

- ❖ Provides an interface to treat the network as a *data stream*
- ❖ Provides different protocols to interface between source and destination:
  - e.g., Transmission Control Protocol (TCP), User Datagram Protocol (UDP)
  - These protocols still work with packets, but manages their order, reliability, multiple applications using the network...

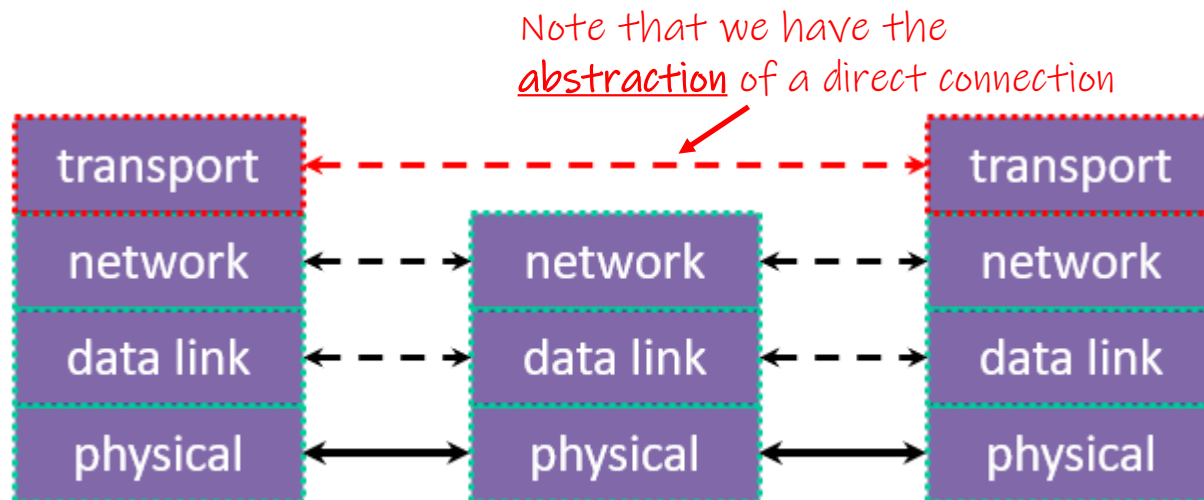

# The Transport Layer (TCP)

- ❖ Transmission Control Protocol (TCP):
  - Provides applications with reliable, ordered, congestion-controlled byte streams
    - Sends stream data as multiple IP packets (differentiated by sequence numbers) and retransmits them as necessary
    - When receiving, puts packets back in order and detects missing packets
  - A single host (IP address) can have up to  $2^{16} = 65,535$  “ports”
    - Kind of like an apartment number at a postal address (your applications are the residents who get mail sent to an apt. #)

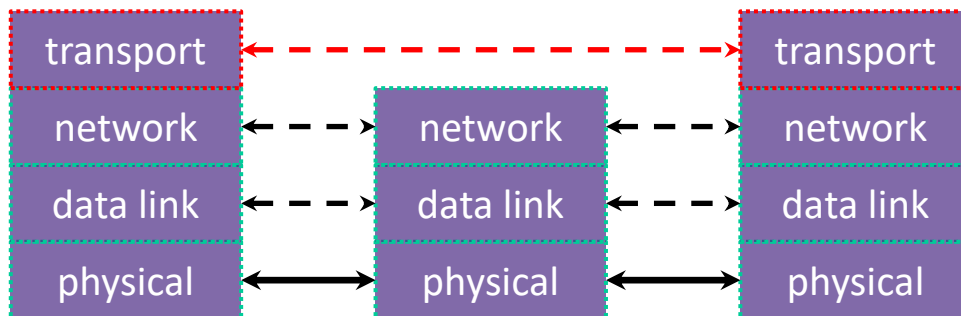

# The Transport Layer (TCP)

- ❖ Packet encapsulation – one more nested layer!

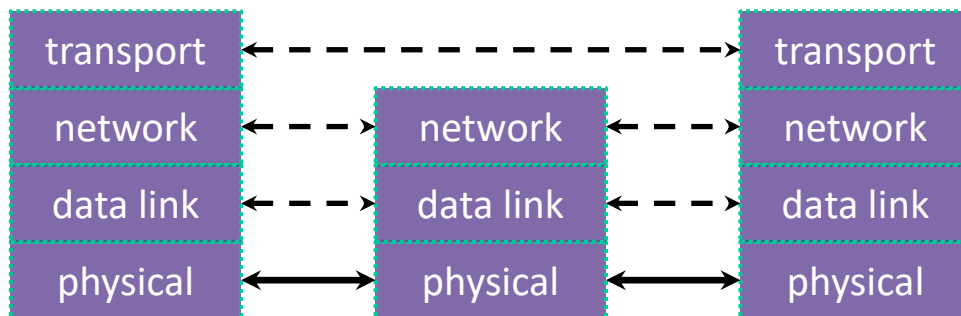
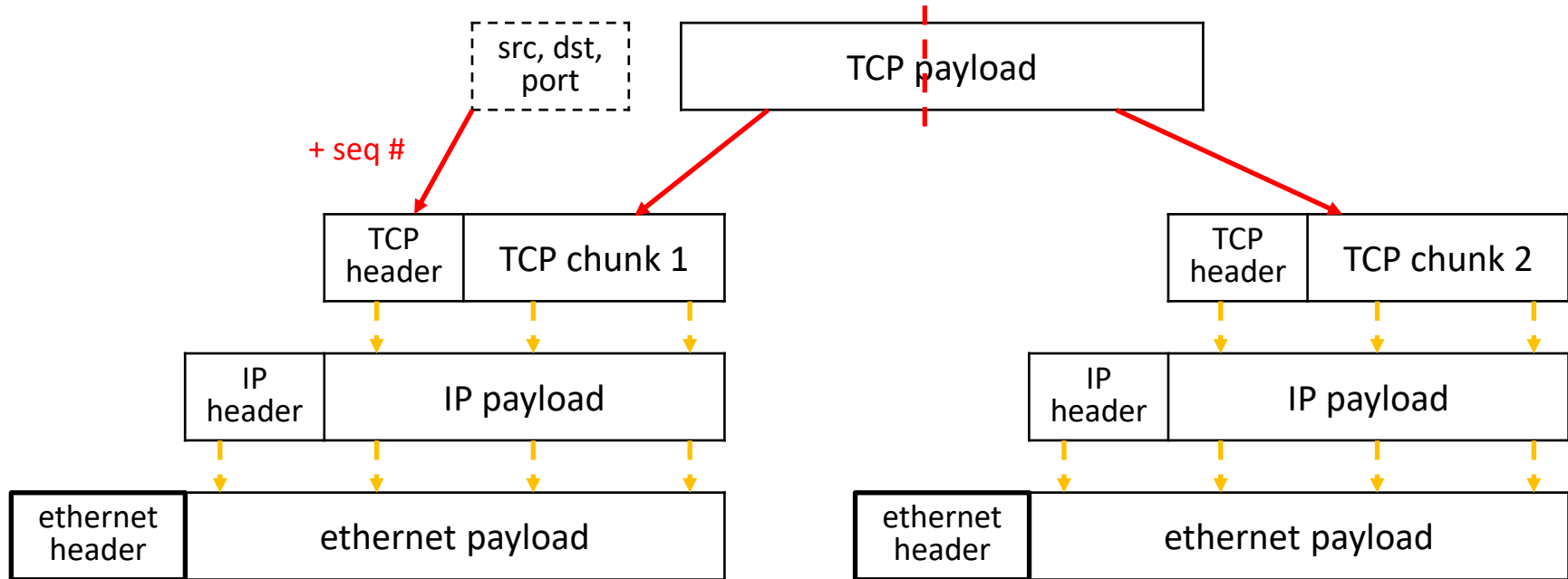

# The Transport Layer (TCP)

- ❖ Applications use OS services to establish TCP streams:
  - The “Berkeley sockets” API
    - A set of OS system calls (POSIX)
  - Clients **connect** () to a server IP address + application port number
  - Servers **listen** () for and **accept** () client connections
  - Clients and servers **read** () and **write** () data to each other

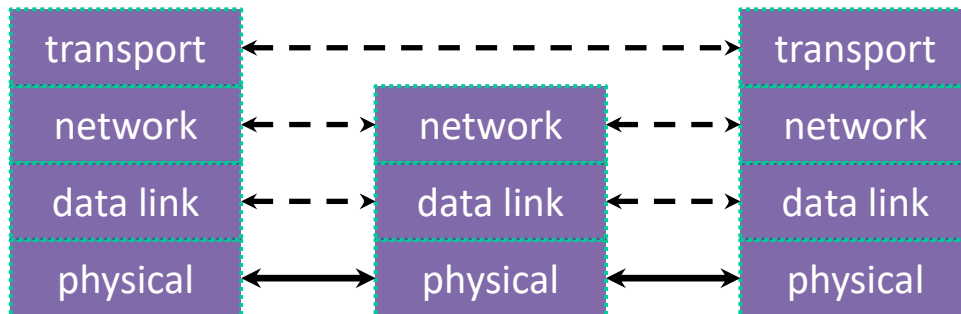

# The Transport Layer (UDP)

- ❖ User Datagram Protocol (UDP):
  - Provides applications with *unreliable* packet delivery
  - UDP is a really thin, simple layer on top of IP
    - Datagrams still are fragmented into multiple IP packets

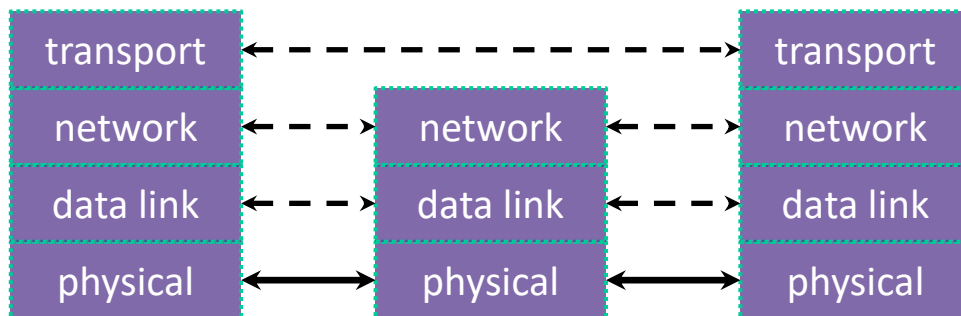

# The Transport Layer

**TCP:**



**UDP:**

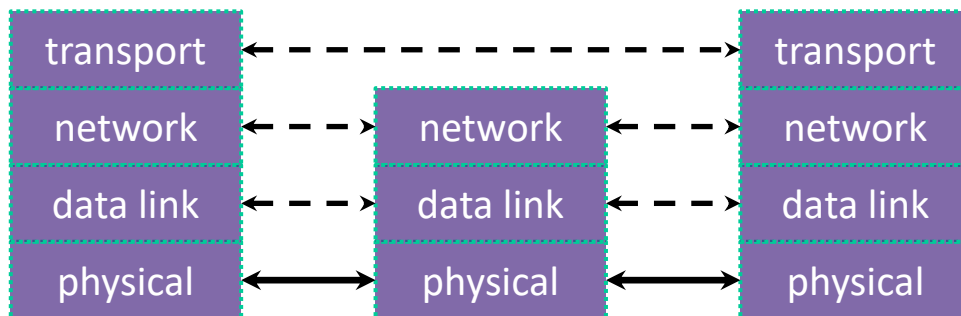

# The (Mostly Missing) Layers 5 & 6

- ❖ Layer 5: Session Layer
  - Supposedly handles establishing and terminating application sessions
  - Remote Procedure Call (RPC) kind of fits in here
- ❖ Layer 6: Presentation Layer
  - Supposedly maps application-specific data units into a more network-neutral representation
  - Encryption (SSL) kind of fits in here

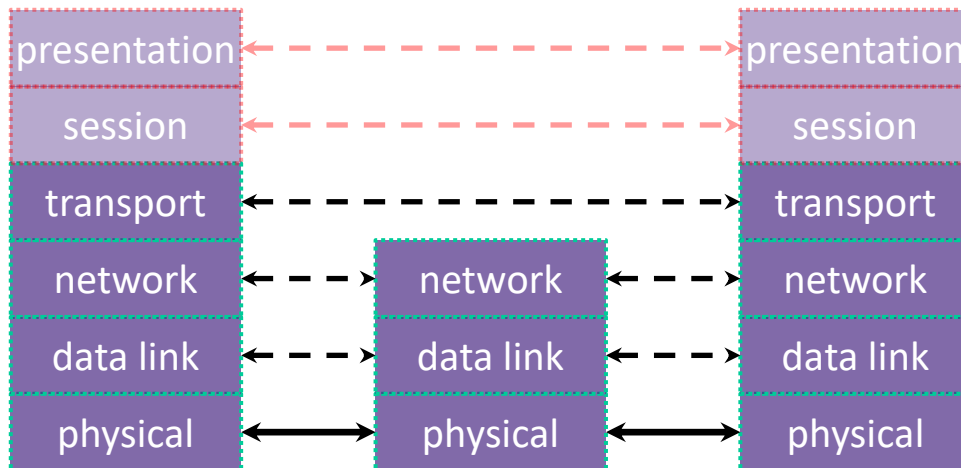



# The Application Layer

- ❖ Application protocols
  - The format and meaning of messages between application entities
  - *e.g.*, HTTP is an application-level protocol that dictates how web browsers and web servers communicate
    - HTTP is implemented *on top of* TCP streams

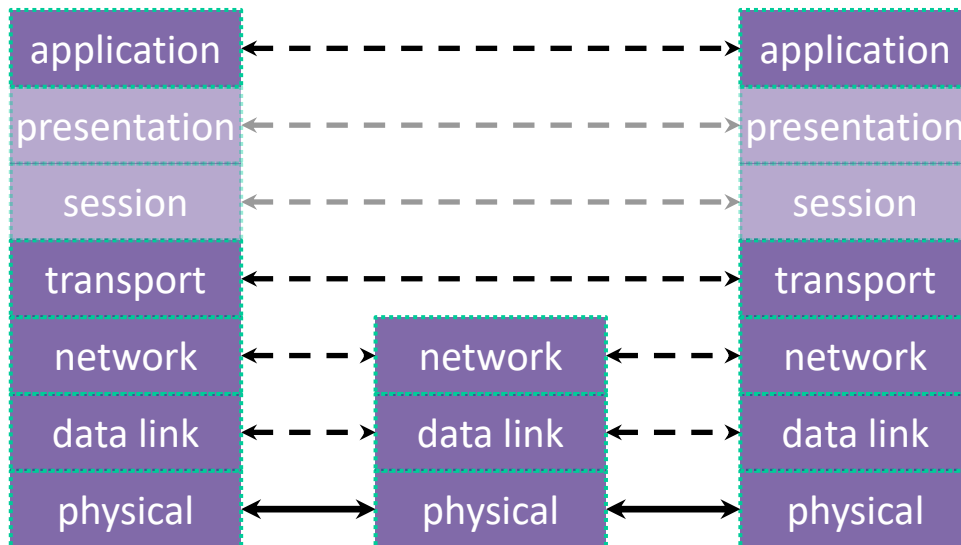

# The Application Layer

## ❖ Packet encapsulation:

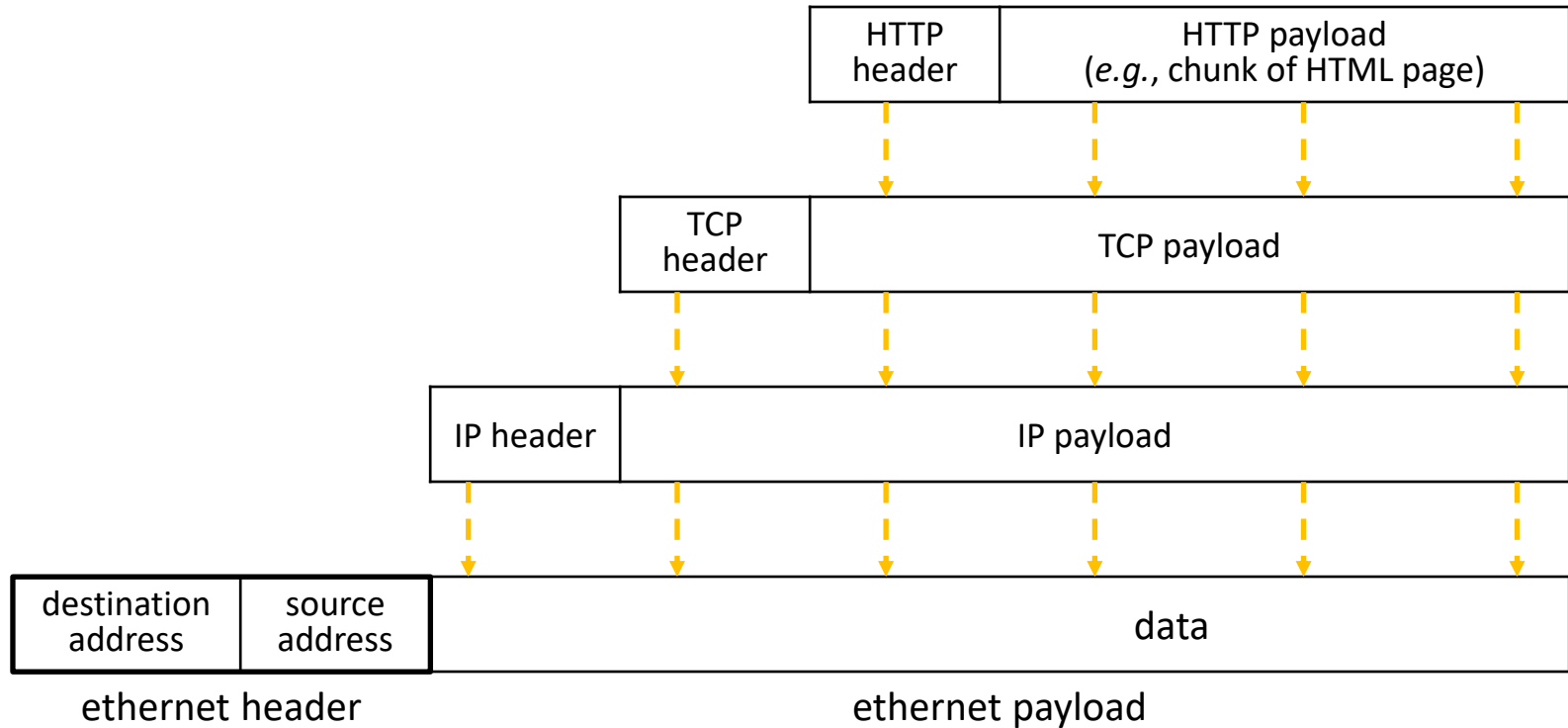

# The Application Layer

- ❖ Packet encapsulation:

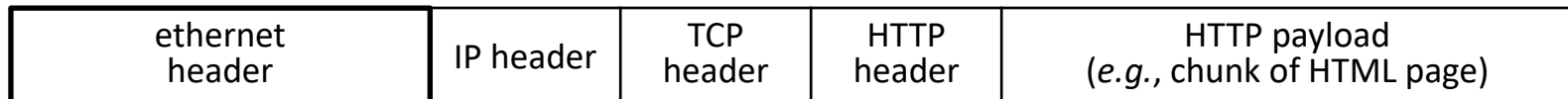

# The Application Layer

- ❖ Popular application-level protocols:
  - **DNS:** translates a domain name (*e.g.*, [www.google.com](http://www.google.com)) into one or more IP addresses (*e.g.*, 74.125.197.106)
    - Domain Name System
    - An hierarchy of DNS servers cooperate to do this
  - **HTTP:** web protocols
    - Hypertext Transfer Protocol
  - **SMTP, IMAP, POP:** mail delivery and access protocols
    - Secure Mail Transfer Protocol, Internet Message Access Protocol, Post Office Protocol
  - **SSH:** secure remote login protocol
    - Secure Shell
  - **bittorrent:** peer-to-peer, swarming file sharing protocol

# netcat demo (if time)

- ❖ netcat (`nc`) is “a computer networking utility for reading from and writing to network connections using TCP or UDP”
  - <https://en.wikipedia.org/wiki/Netcat>
  - Listen on port: `nc -l <port>`
  - Connect: `nc <IPaddr> <port>`
    - Local host: `127.0.0.1`