



CSE 332: Data Structures & Parallelism

Lecture 24: P, NP, NP-Complete (part 1)

Ruth Anderson

Spring 2023

Agenda (for next 2 lectures)

- A Few Problems:
 - Euler Circuits
 - Hamiltonian Circuits
- Intractability: P and NP
- NP-Complete
- What now?

Try it!

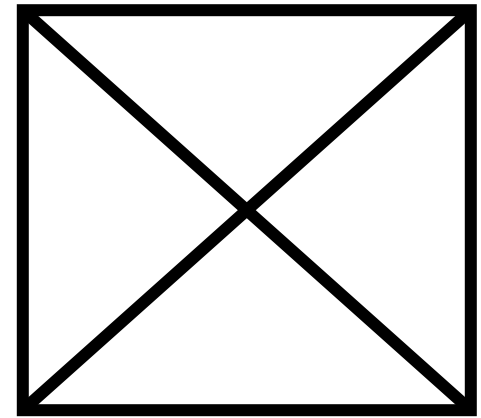
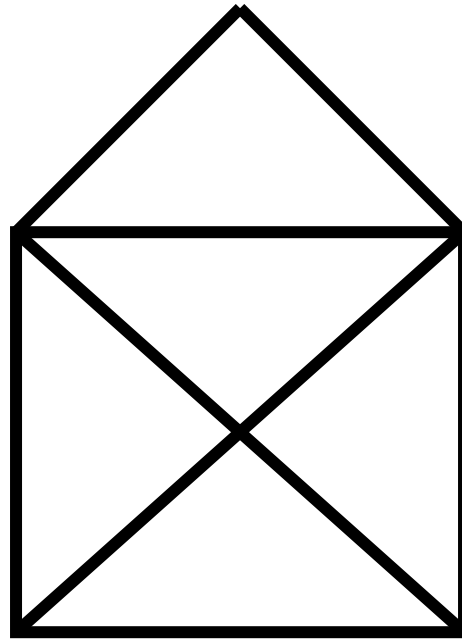
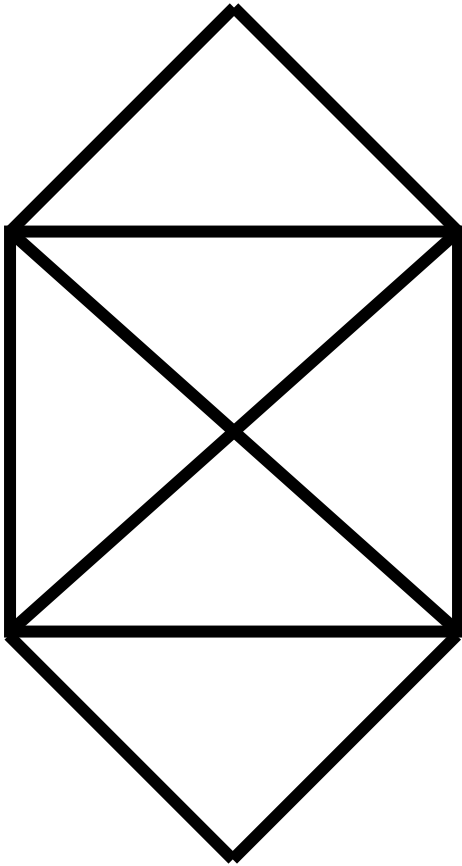

Which of these can you draw (trace all edges) without lifting your pencil, drawing each line only once?

Can you start and end at the same point?

Your First Task

- Your company has to inspect a set of roads between cities by driving over each of them.
- Driving over the roads costs money (fuel), and there are a lot of roads.
- Your boss wants you to figure out how to drive over each road exactly once, returning to your starting point.

Euler Circuits

- Euler circuit: a path through a graph that *visits each edge exactly once and starts and ends at the same vertex*
- Named after Leonhard Euler (1707-1783), who cracked this problem and founded graph theory in 1736
- An Euler circuit exists *iff*
 - the graph is connected and
 - each vertex has **even** degree (= # of edges on the vertex)

The Road Inspector: Finding Euler Circuits

Given a connected, undirected graph $G = (V, E)$, find an Euler circuit in G

Can check if one exists:

- Check if all vertices have even degree

Basic Euler Circuit Algorithm:

1. Do an edge walk from a start vertex until you are back to the start vertex.
 - You never get stuck because of the even degree property.
2. “Remove” the walk, leaving several components each with the even degree property.
 - Recursively find Euler circuits for these.
3. Splice all these circuits into an Euler circuit

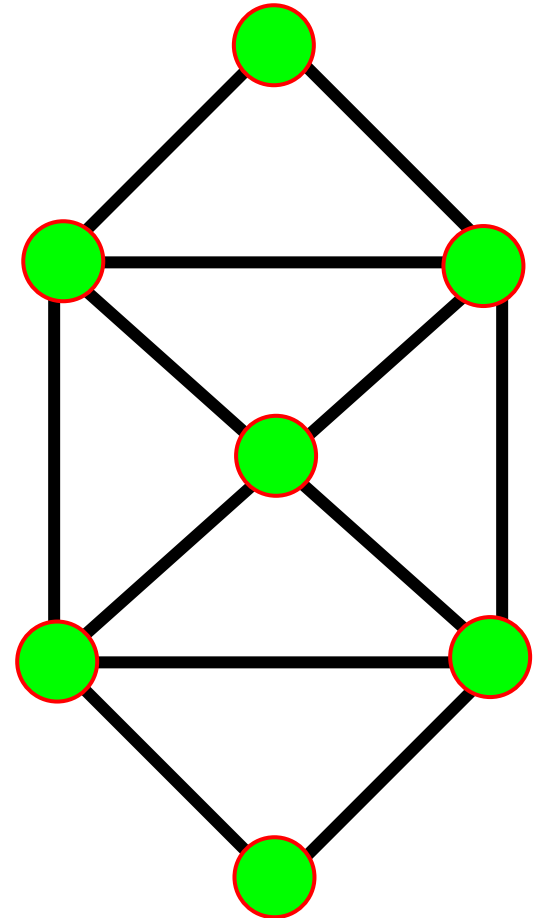

Euler Circuit Example

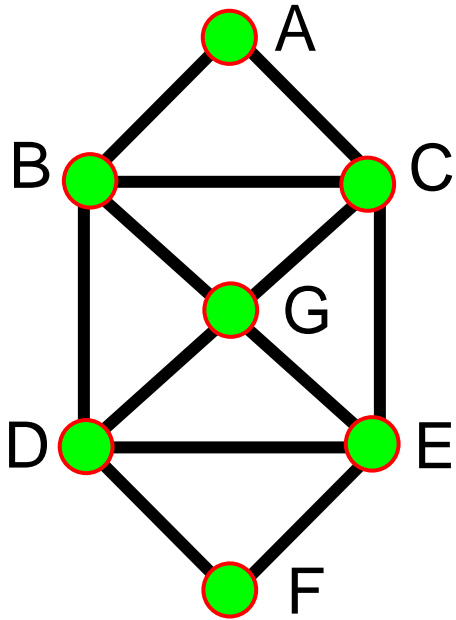

Euler(A) :

Euler Circuit Example

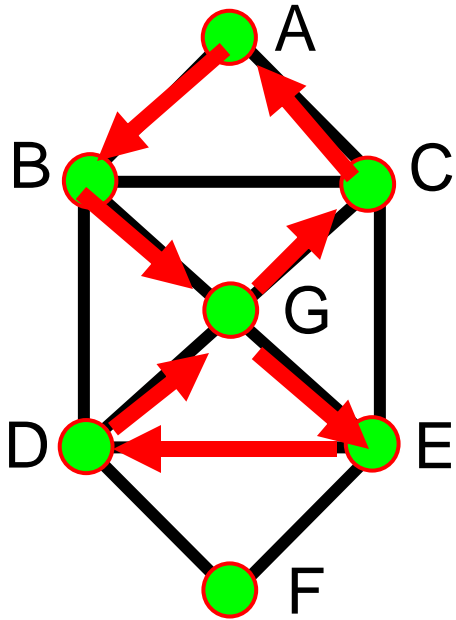

Euler(A) :
A B G E D G C A

Euler Circuit Example

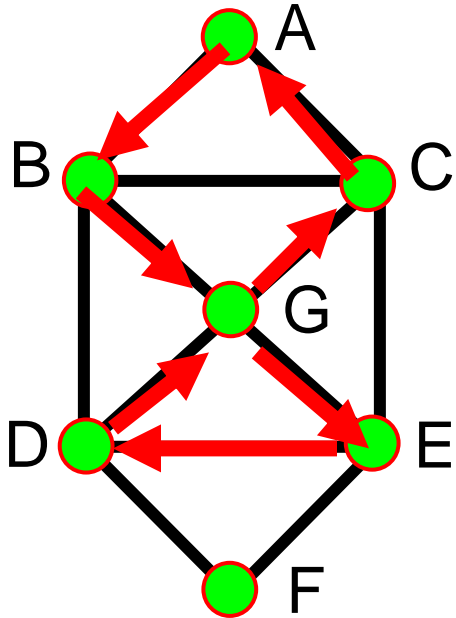

Euler(A) :
A B G E D G C A

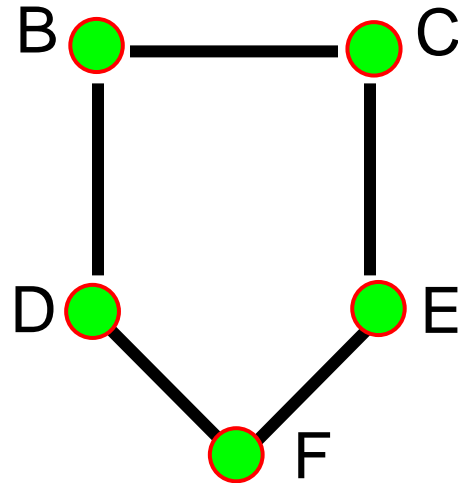

Euler(B)

Euler Circuit Example

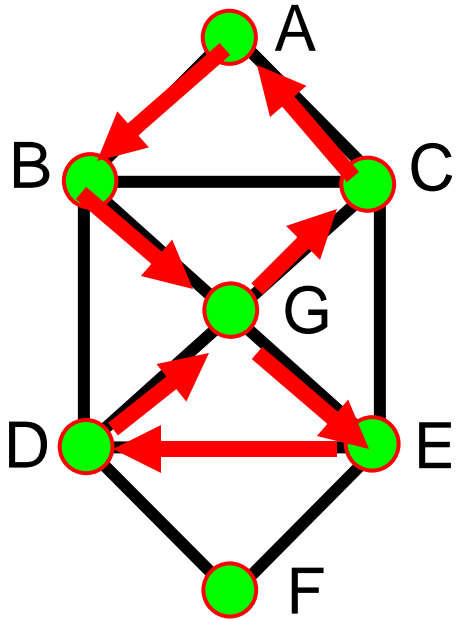

Euler(A) :
A B G E D G C A

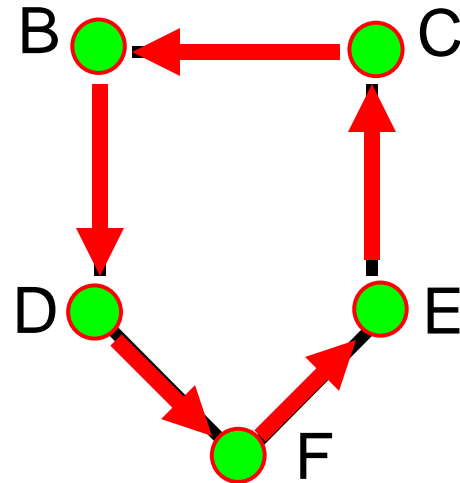

Euler(B):
B D F E C B

Euler Circuit Example

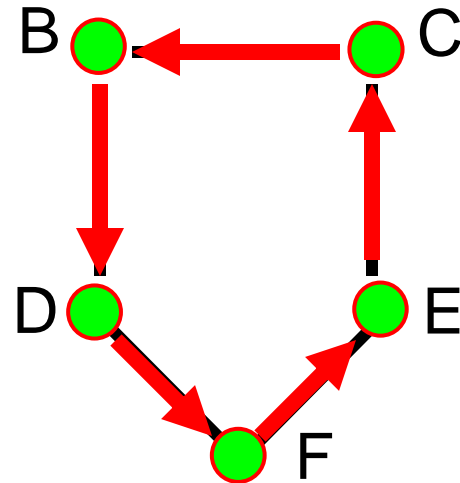
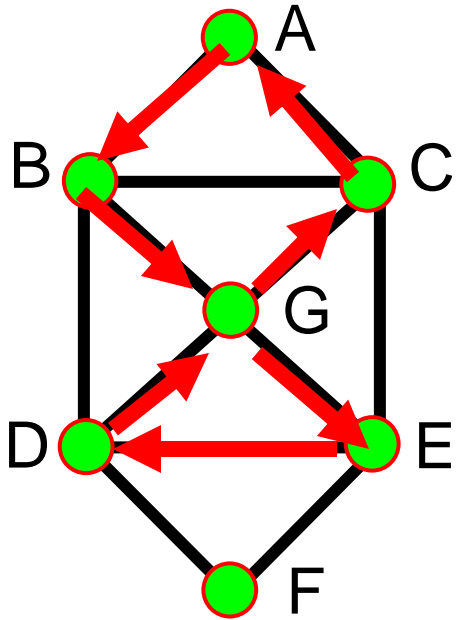

Euler(A) :
A B G E D G C A

Euler(B):
B D F E C B

Splice

5/31/2023 A B D F E C B G E D G C A

Your Second Task

- Your boss is pleased...and assigns you a new task.
- Your company has to send someone by car to a set of cities.
- The primary cost is the exorbitant toll going into each city.
- Your boss wants you to figure out how to drive to each city exactly once, returning in the end to the city of origin.

Hamiltonian Circuits

- **Euler circuit:** A cycle that goes through each *edge* exactly once
- **Hamiltonian circuit:** A cycle that goes through each *vertex* exactly once
- Does graph I have:
 - An Euler circuit?
 - A Hamiltonian circuit?
- Does graph II have:
 - An Euler circuit?
 - A Hamiltonian circuit?
- Which problem sounds harder?

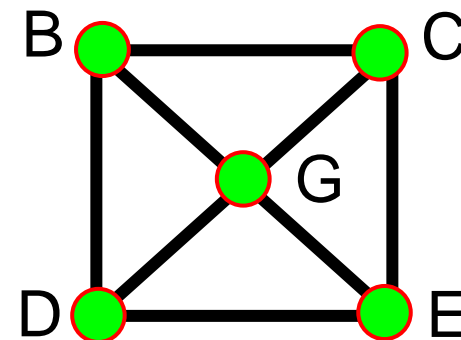
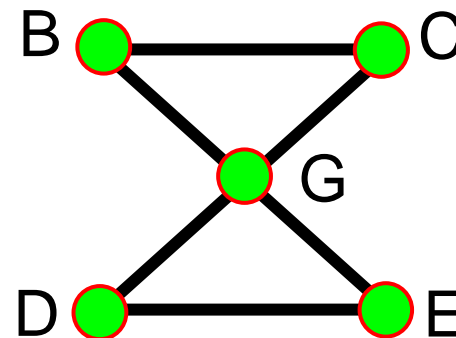

Finding Hamiltonian Circuits

- **Problem:** Find a Hamiltonian circuit in a connected, undirected graph G
- **One solution:** Search through *all paths* to find one that visits each vertex exactly once
 - Can use your favorite graph search algorithm to find paths
- This is an *exhaustive search* (“brute force”) algorithm
- Worst case: need to search all paths
 - How many paths??

Analysis of Exhaustive Search Algorithm

Worst case: need to search all paths

– How many paths?

Can depict these paths as a *search tree*:

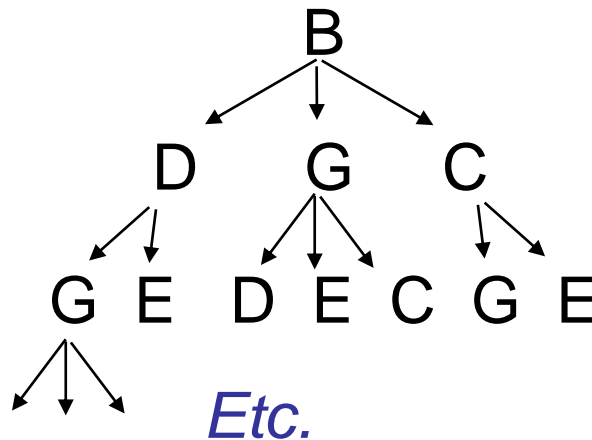
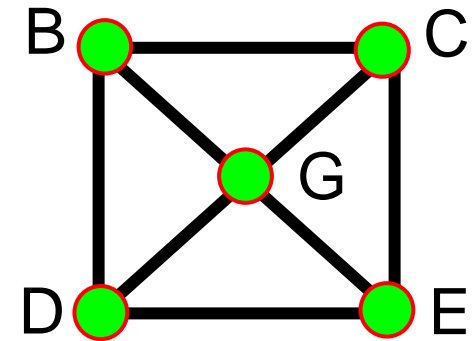

Analysis of Exhaustive Search Algorithm

- Let the *average* branching factor of each node in this tree be b
- $|V|$ vertices, each with $\approx b$ branches
- Total number of paths $\approx b \cdot b \cdot b \dots \cdot b$
- Worst case \rightarrow

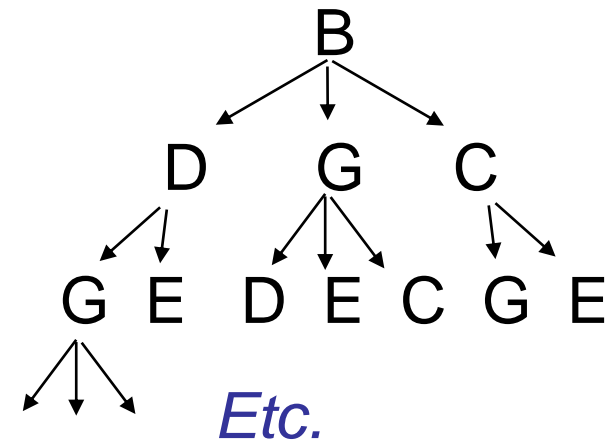

Search tree of paths from B

Running Times

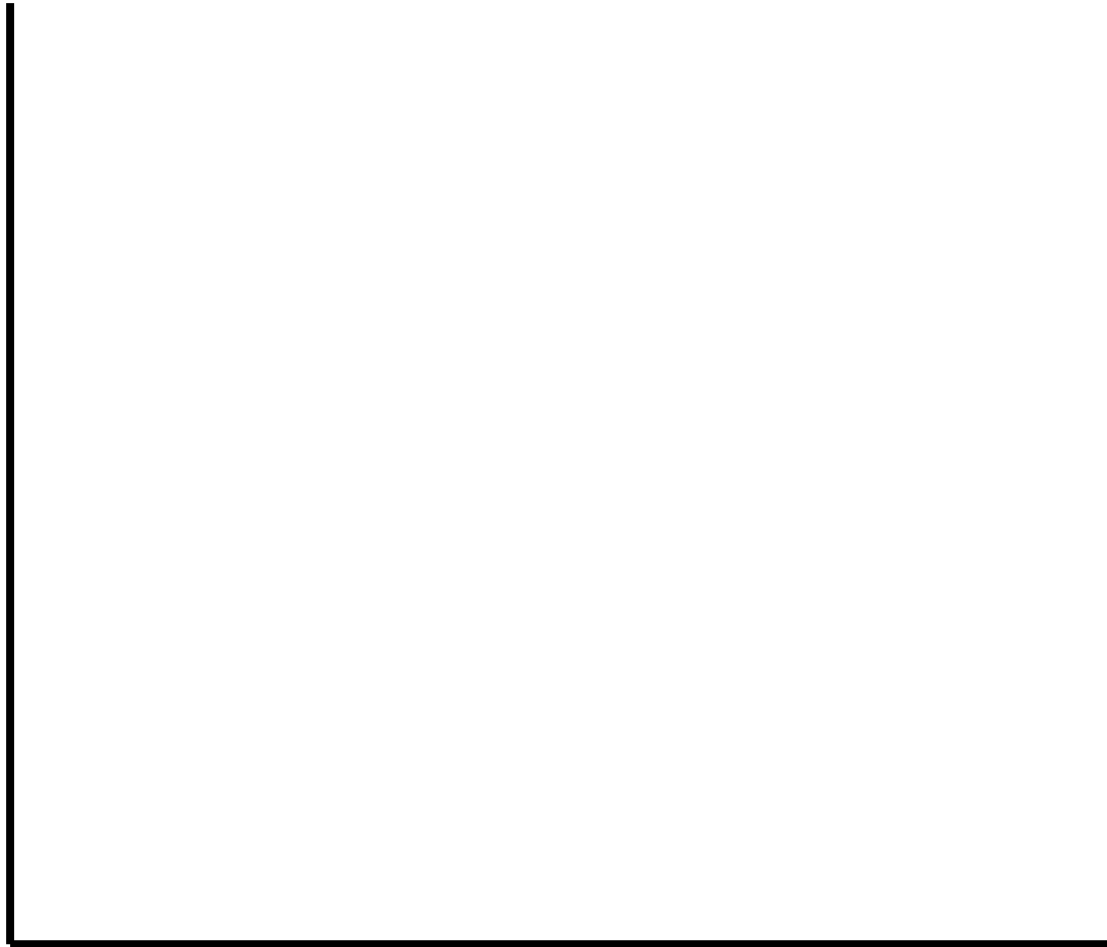

More Running Times

Table 2.1 The running times (rounded up) of different algorithms on inputs of increasing size, for a processor performing a million high-level instructions per second. In cases where the running time exceeds 10^{25} years, we simply record the algorithm as taking a very long time.

	n	$n \log_2 n$	n^2	n^3	1.5^n	2^n	$n!$
$n = 10$	< 1 sec	< 1 sec	< 1 sec	< 1 sec	< 1 sec	< 1 sec	4 sec
$n = 30$	< 1 sec	< 1 sec	< 1 sec	< 1 sec	< 1 sec	18 min	10^{25} years
$n = 50$	< 1 sec	< 1 sec	< 1 sec	< 1 sec	11 min	36 years	very long
$n = 100$	< 1 sec	< 1 sec	< 1 sec	1 sec	12,892 years	10^{17} years	very long
$n = 1,000$	< 1 sec	< 1 sec	1 sec	18 min	very long	very long	very long
$n = 10,000$	< 1 sec	< 1 sec	2 min	12 days	very long	very long	very long
$n = 100,000$	< 1 sec	2 sec	3 hours	32 years	very long	very long	very long
$n = 1,000,000$	1 sec	20 sec	12 days	31,710 years	very long	very long	very long

Somewhat old, from Rosen

Polynomial vs. Exponential Time

- All of the algorithms we have discussed in this class have been **polynomial time** algorithms:
 - Examples: $O(\log N)$, $O(N)$, $O(N \log N)$, $O(N^2)$
 - Algorithms whose running time is $O(N^k)$ for some $k > 0$
- **Exponential time** b^N is asymptotically worse than any polynomial function N^k for any k

The Complexity Class P

- P is the set of all problems that can be solved in *polynomial worst case time*
 - All *problems* that have some *algorithm* whose running time is $O(N^k)$ for some k
- **Examples of problems in P:**
sorting, shortest path, Euler circuit, *etc.*



P

Sorting
Shortest Path
Euler Circuit

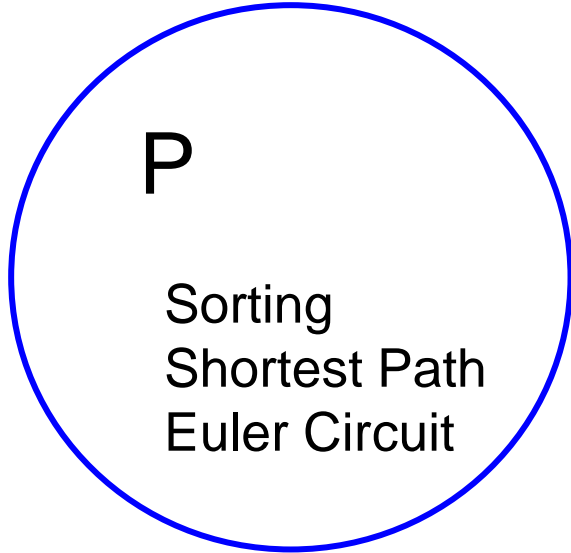

Hamiltonian Circuit

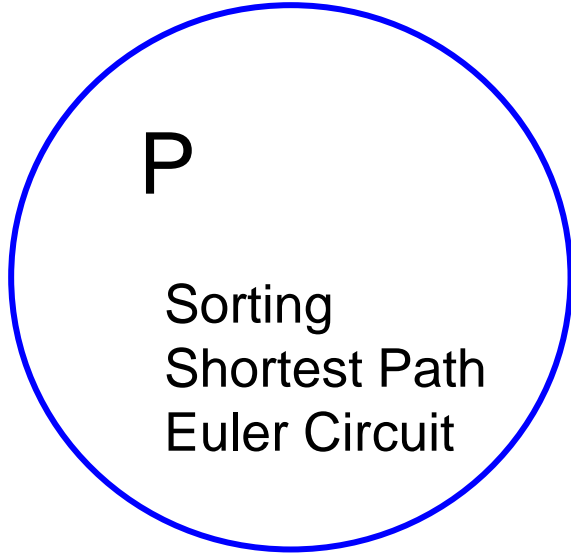

Hamiltonian Circuit
Satisfiability (SAT)
Vertex Cover
Travelling Salesman

Satisfiability

$$(\neg x_1 \vee x_2 \vee x_4) \wedge (x_1 \vee \neg x_3 \vee x_4) \wedge (x_2 \vee \neg x_4 \vee \neg x_5)$$

Input: a logic formula of size **m** containing **n** variables

Output: An assignment of Boolean values to the variables in the formula such that the formula is true

Algorithm: Try every variable assignment

Vertex Cover:

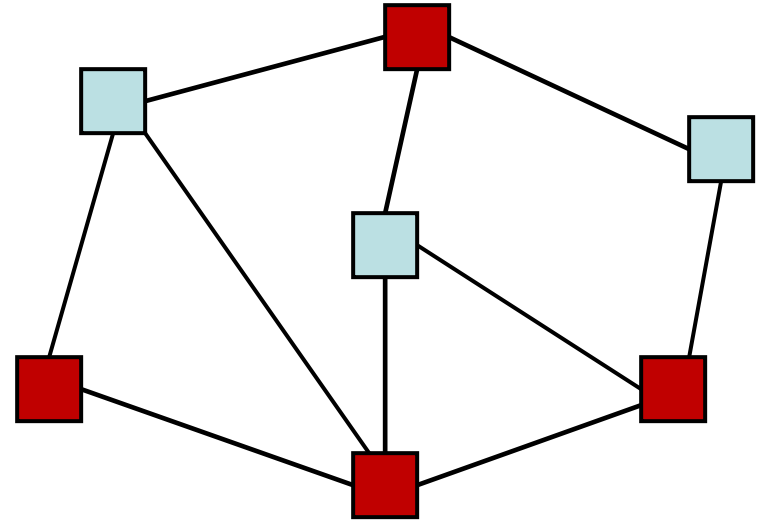

Input: A graph (V, E) and a number m

Output: A subset S of V such that for every edge (u, v) in E , at least one of u or v is in S and $|S|=m$ (if such an S exists)

Algorithm: Try every subset of vertices of size m

Traveling Salesman

Input: A complete *weighted* graph (V, E) and a number m

Output: A circuit that visits each vertex exactly once and has total cost $< m$ if one exists

Algorithm: Try every path, stop if find cheap enough one