



# CSE 332: Data Structures & Parallelism

## Lecture 19: Introduction to Graphs

Ruth Anderson  
Winter 2022

# *Today*

- Graphs
  - Intro & Definitions

# Graphs

- A graph is a formalism for representing relationships among items
  - Very general definition because very general concept

- A graph is a pair

$$G = (V, E)$$

- A set of vertices, also known as nodes

$$V = \{v_1, v_2, \dots, v_n\}$$

- A set of edges

$$E = \{e_1, e_2, \dots, e_m\}$$

- Each edge  $e_i$  is a pair of vertices  $(v_j, v_k)$
- An edge “connects” the vertices

- Graphs can be directed or undirected

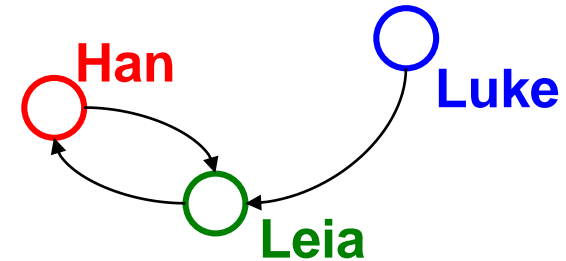

$$V = \{\text{Han}, \text{Leia}, \text{Luke}\}$$

$$E = \{(\text{Luke}, \text{Leia}), (\text{Han}, \text{Leia}), (\text{Leia}, \text{Han})\}$$

# *An ADT?*

- Can think of graphs as an ADT with operations like `isEdge ( (vj, vk) )`
- But it is unclear what the “standard operations” are
- Instead we tend to develop algorithms over graphs and then use data structures that are efficient for those algorithms
- Many important problems can be solved by:
  1. Formulating them in terms of graphs
  2. Applying a standard graph algorithm
- To make the formulation easy and standard, we have a lot of *standard terminology* about graphs

# *Some graphs*

For each, what are the **vertices** and what are the **edges**?

- Web pages with links
- Facebook friends
- “Input data” for the Kevin Bacon game
- Methods in a program that call each other
- Road maps (e.g., Google maps)
- Airline routes
- Family trees
- Course pre-requisites
- ...

Wow: Using the same algorithms for problems across so many domains sounds like “core computer science and engineering”

# Undirected Graphs

- In **undirected graphs**, edges have no specific direction
  - Edges are always “two-way”

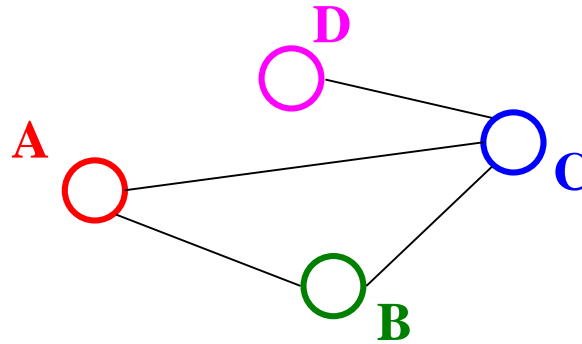

- Thus,  $(u, v) \in E$  implies  $(v, u) \in E$ .
  - Only one of these edges needs to be in the set; the other is implicit
- **Degree** of a vertex: number of edges containing that vertex
  - Put another way: the number of adjacent vertices

# Directed Graphs

- In **directed graphs** (sometimes called **digraphs**), edges have a direction

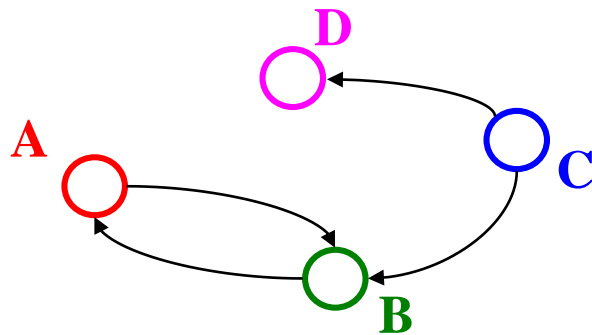

or

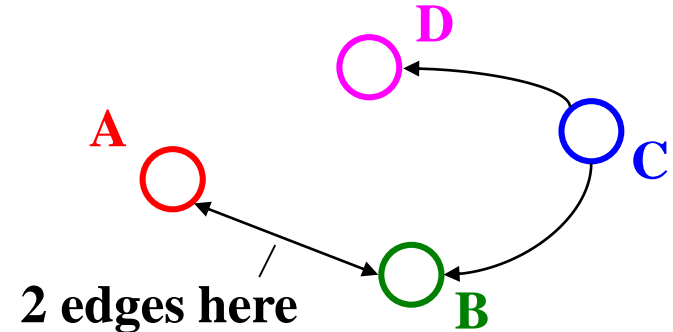

- Thus,  $(u, v) \in \mathbf{E}$  does *not* imply  $(v, u) \in \mathbf{E}$ .
  - Let  $(u, v) \in \mathbf{E}$  mean  $u \rightarrow v$
  - Call  $u$  the **source** and  $v$  the **destination**
- In-Degree** of a vertex: number of in-bound edges, i.e., edges where the vertex is the destination
- Out-Degree** of a vertex: number of out-bound edges i.e., edges where the vertex is the source

# *Self-edges, connectedness*

- A **self-edge** a.k.a. a **loop** is an edge of the form  $(u, u)$ 
  - Depending on the use/algorithm, a graph may have:
    - No self edges
    - Some self edges
    - All self edges (often therefore implicit, but we will be explicit)
- A node can have a degree / in-degree / out-degree of **zero**
- A graph does not have to be **connected** (In an undirected graph, this means we can follow edges from any node to every other node), even if every node has non-zero degree

# More notation

For a graph  $G = (V, E)$ :

- $|V|$  is the number of vertices
- $|E|$  is the number of edges
  - Minimum?
  - Maximum for undirected?
  - Maximum for directed?
- If  $(u, v) \in E$ 
  - Then  $v$  is a **neighbor** of  $u$ , i.e.,  $v$  is **adjacent** to  $u$
  - Order matters for directed edges
    - $u$  is not **adjacent** to  $v$  unless  $(v, u) \in E$

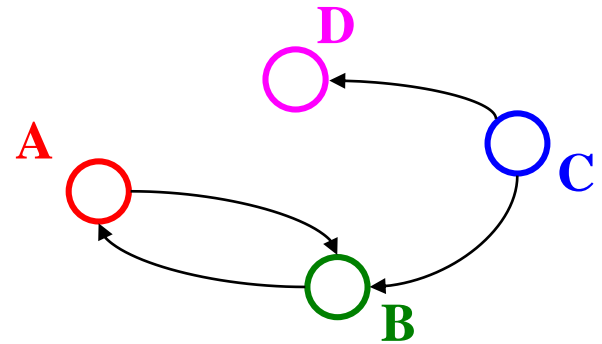

$$V = \{A, B, C, D\}$$

$$E = \{ (C, B), (A, B), (B, A), (C, D) \}$$

# *Examples again*

Which would use **directed edges**? Which would have **self-edges**?  
Which could have **0-degree nodes**?

- Web pages with links
- Facebook friends
- “Input data” for the Kevin Bacon game
- Methods in a program that call each other
- Road maps (e.g., Google maps)
- Airline routes
- Family trees
- Course pre-requisites
- ...

# Weighted graphs

- In a weighed graph, each edge has a **weight** a.k.a. **cost**
  - Typically numeric (most examples will use ints)
  - *Orthogonal* to whether graph is directed
  - Some graphs allow *negative weights*; many don't

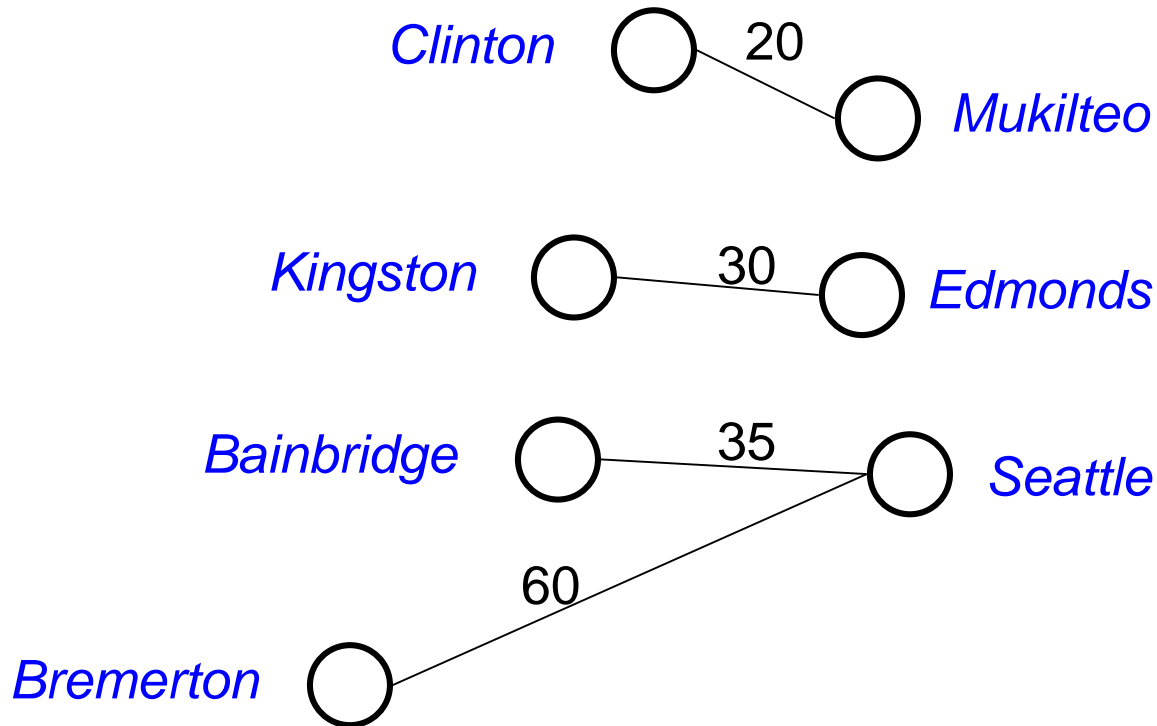

# Examples

What, if anything, might **weights** represent for each of these? Do **negative weights** make sense?

- Web pages with links
- Facebook friends
- “Input data” for the Kevin Bacon game
- Methods in a program that call each other
- Road maps (e.g., Google maps)
- Airline routes
- Family trees
- Course pre-requisites
- ...

# Paths and Cycles

- A **path** is a list of vertices  $[v_0, v_1, \dots, v_n]$  such that  $(v_i, v_{i+1}) \in E$  for all  $0 \leq i < n$ . Say “a path from  $v_0$  to  $v_n$ ”
- A **cycle** is a path that begins and ends at the same node ( $v_0 = v_n$ )

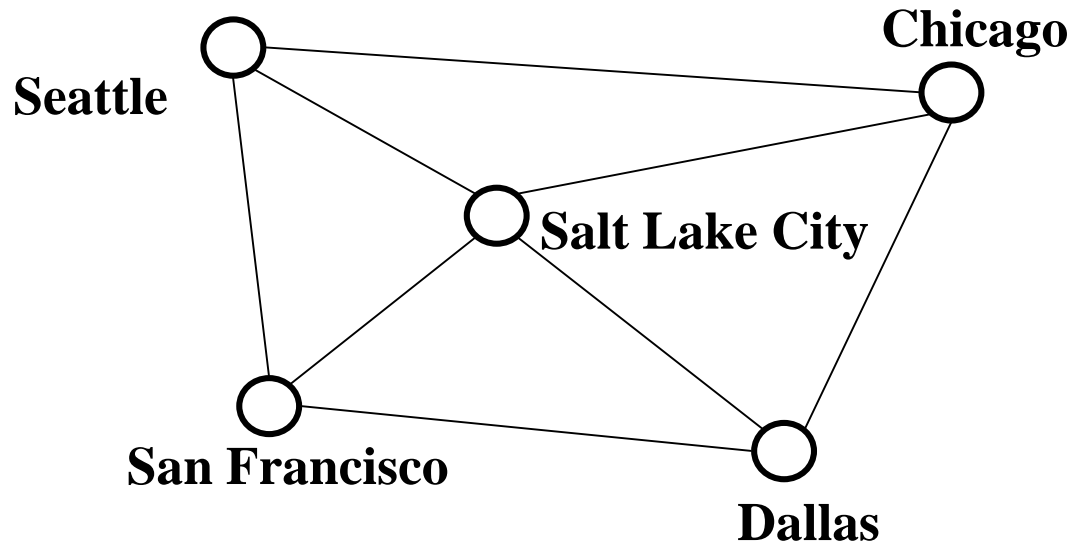

Example path (that also happens to be a cycle):

[Seattle, Salt Lake City, Chicago, Dallas, San Francisco, Seattle]

# Path Length and Cost

- **Path length:** Number of *edges* in a path (also called “unweighted cost”)
- **Path cost:** Sum of the weights of each edge

Example where:

$P = [\text{Seattle}, \text{Salt Lake City}, \text{Chicago}, \text{Dallas}, \text{San Francisco}]$

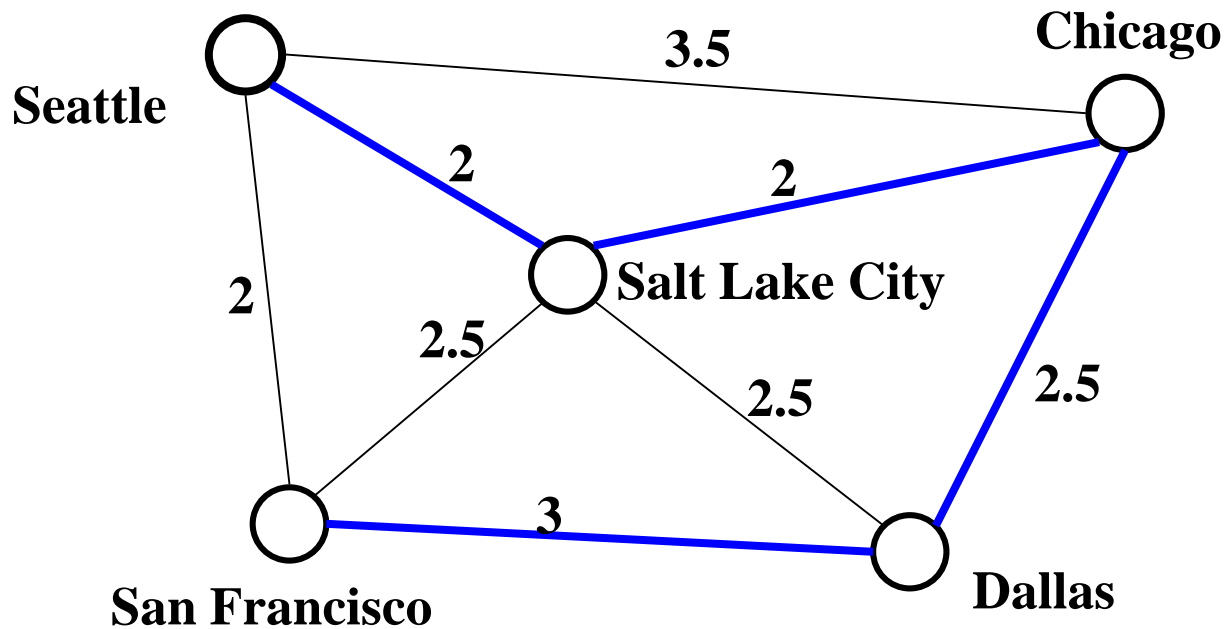

$\text{length}(P) = 4$   
 $\text{cost}(P) = 9.5$

# *Paths/cycles in directed graphs*

Example:

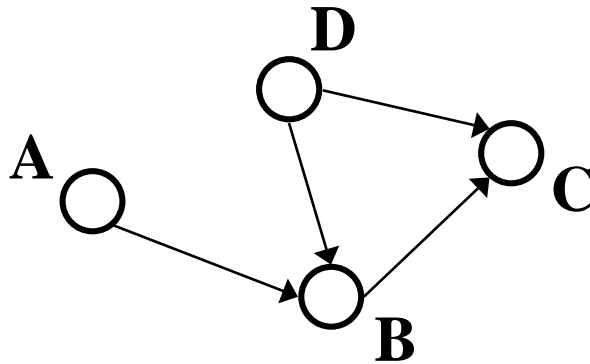

Is there a **path** from A to D?

Does the graph contain any **cycles**?

# Undirected graph connectivity

- An undirected graph is **connected** if for all pairs of vertices  $u, v$ , there exists a *path* from  $u$  to  $v$

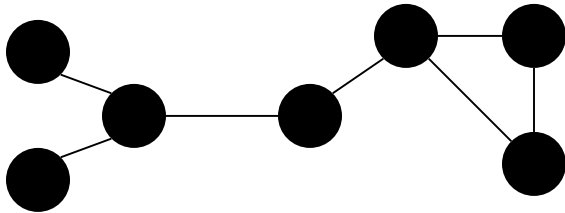

**Connected graph**

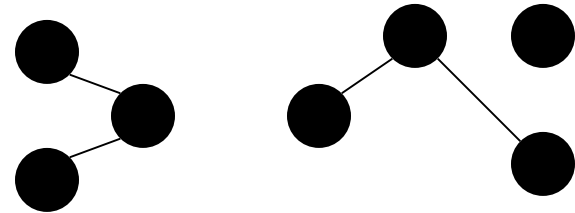

**Disconnected graph**

- An undirected graph is **complete**, a.k.a. **fully connected** if for all pairs of vertices  $u, v$ , there exists an edge from  $u$  to  $v$

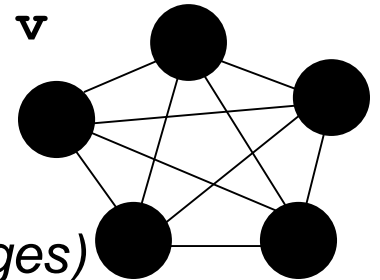

(plus self edges)

# Directed graph connectivity

- A directed graph is **strongly connected** if there is a path from every vertex to every other vertex
- A directed graph is **weakly connected** if there is a path from every vertex to every other vertex *ignoring direction of edges*
- A **complete** a.k.a. **fully connected** directed graph has an edge from every vertex to every other vertex

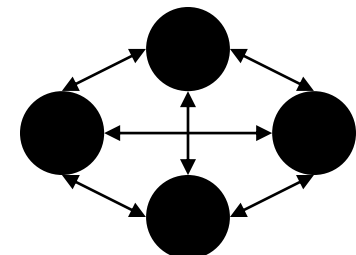
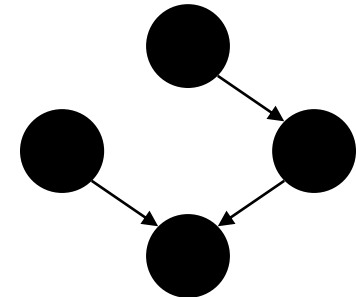
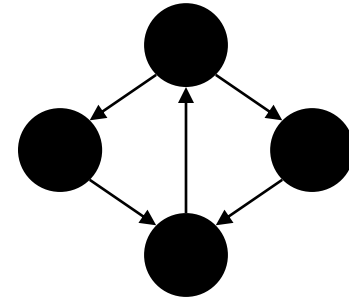

*(plus self edges)*

# Examples

For undirected graphs: **connected?**

For directed graphs: **strongly connected?** **weakly connected?**

- Web pages with links
- Facebook friends
- “Input data” for the Kevin Bacon game
- Methods in a program that call each other
- Road maps (e.g., Google maps)
- Airline routes
- Family trees
- Course pre-requisites
- ...

# *Trees as graphs*

When talking about graphs,  
we say a **tree** is a graph that is:

- undirected
- acyclic
- connected

So all trees are graphs, but not  
all graphs are trees

How does this relate to the trees  
we know and love?...

Example:

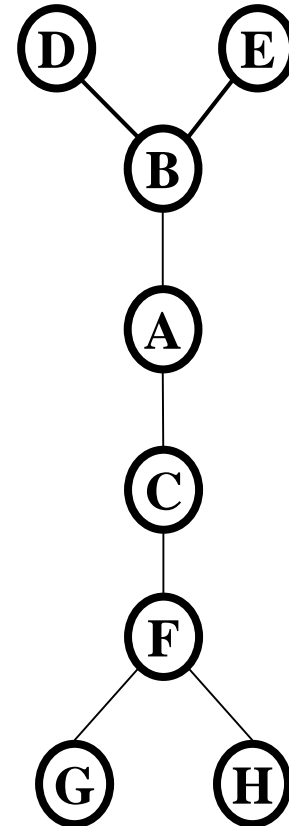

# Rooted Trees

- We are more accustomed to **rooted trees** where:
  - We identify a unique (“special”) root
  - We think of edges as **directed**: parent to children
- Given a tree, once you pick a root, you have a unique rooted tree (just drawn differently and with undirected edges)

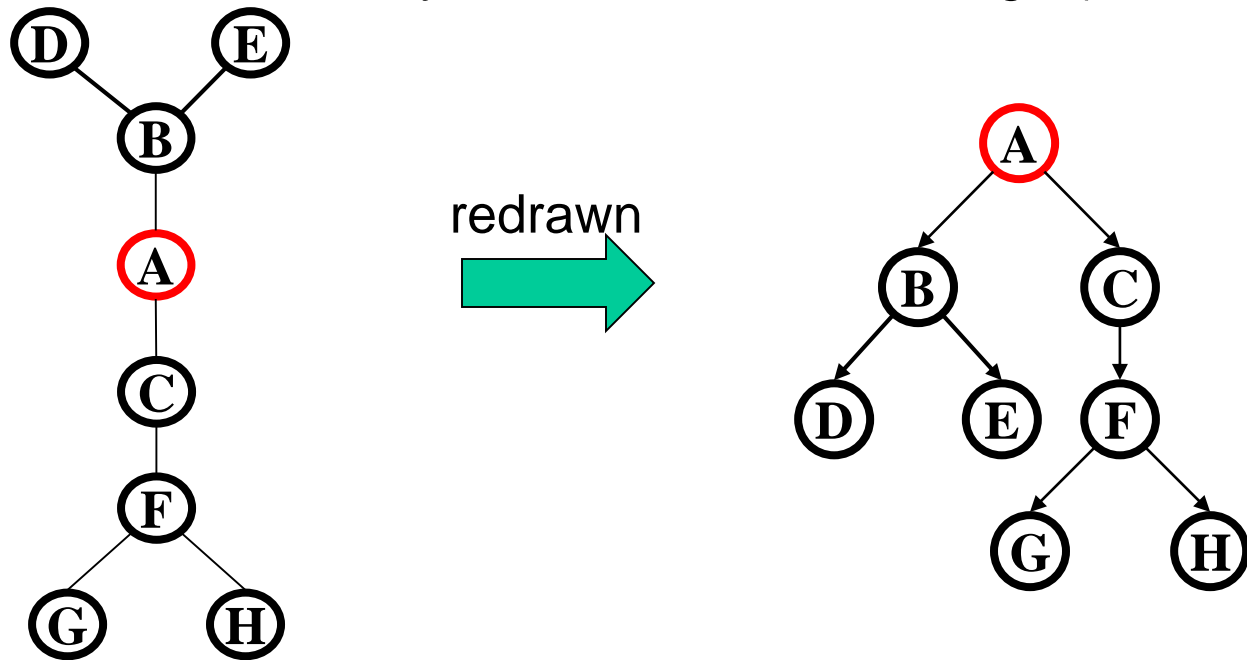

# Rooted Trees (Another example)

- We are more accustomed to **rooted trees** where:
  - We identify a unique (“special”) root
  - We think of edges as **directed**: parent to children
- Given a tree, once you pick a root, you have a unique rooted tree (just drawn differently and with undirected edges)

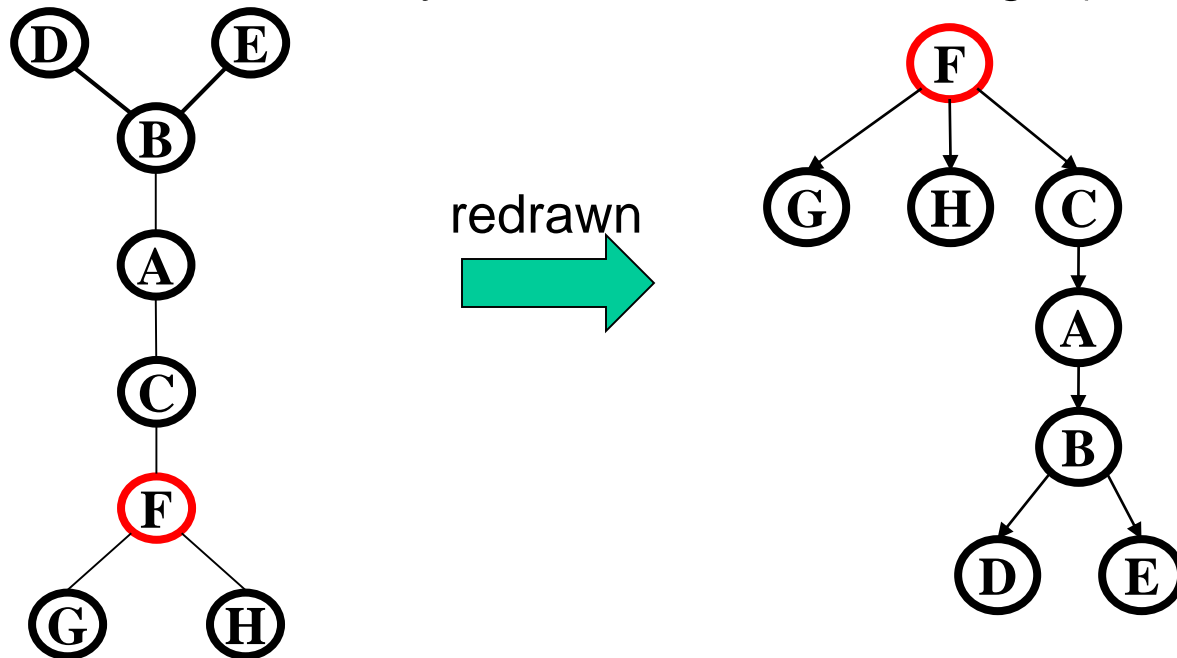

# Directed acyclic graphs (DAGs)

- A **DAG** is a directed graph with no (directed) cycles
  - Every rooted directed tree is a DAG
    - But not every DAG is a rooted directed tree:

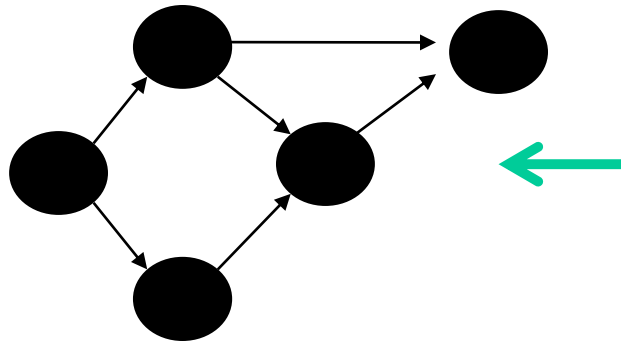

Not a rooted directed tree,  
Has a cycle (in the  
undirected sense)

- Every DAG is a directed graph
  - But not every directed graph is a DAG:

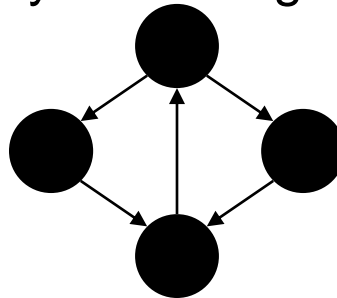

# *Examples*

Which of our **directed**-graph examples do you expect to be a **DAG**?

- Web pages with links
- “Input data” for the Kevin Bacon game
- Methods in a program that call each other
- Airline routes
- Family trees
- Course pre-requisites
- ...

# Density / sparsity

- Recall: In an undirected graph,  $0 \leq |E| < |V|^2$
- Recall: In a directed graph:  $0 \leq |E| \leq |V|^2$
- So for any graph,  $|E|$  is  $O(|V|^2)$
- One more fact: If an undirected graph is *connected*, then  $|E| \geq |V|-1$
- Because  $|E|$  is often much smaller than its maximum size, we do not always approximate as  $|E|$  as  $O(|V|^2)$ 
  - This is a correct bound, it just is often not tight
  - If it is tight, i.e.,  $|E|$  is  $\Theta(|V|^2)$  we say the graph is **dense**
    - More sloppily, dense means “lots of edges”
  - If  $|E|$  is  $O(|V|)$  we say the graph is **sparse**
    - More sloppily, sparse means “most (possible) edges missing”

# *What is the Data Structure?*

- So graphs are really useful for lots of data and questions
  - For example, “what’s the lowest-cost path from  $x$  to  $y$ ”
- But we need a data structure that represents graphs
- The “best one” can depend on:
  - Properties of the graph (e.g., dense versus sparse)
  - The common queries (e.g., “is  $(u, v)$  an edge?” versus “what are the neighbors of node  $u$ ?”)
- So we’ll discuss the two standard graph representations
  - [Adjacency Matrix](#) and [Adjacency List](#)
  - Different trade-offs, particularly time versus space

# Adjacency matrix

- Assign each node a number from 0 to  $|V| - 1$
- A  $|V| \times |V|$  matrix (i.e., 2-D array) of Booleans (or 1 vs. 0)
  - If  $\mathbf{M}$  is the matrix, then  $\mathbf{M}[\mathbf{u}][\mathbf{v}] == \mathbf{true}$  means there is an edge from  $\mathbf{u}$  to  $\mathbf{v}$

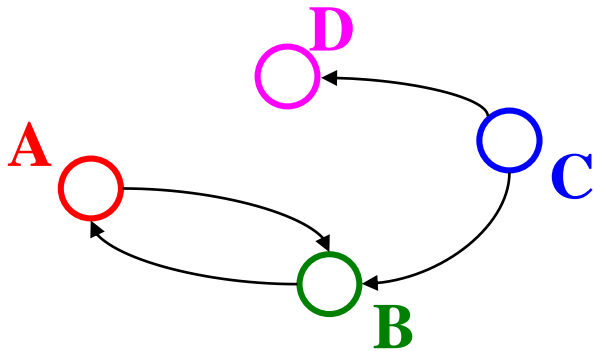

	A	B	C	D
A	F	T	F	F
B	T	F	F	F
C	F	T	F	T
D	F	F	F	F

# Adjacency Matrix Properties

- Running time to:
  - Get a vertex's out-edges:
  - Get a vertex's in-edges:
  - Decide if some edge exists:
  - Insert an edge:
  - Delete an edge:
- Space requirements:
- Best for sparse or dense graphs?

	A	B	C	D
A	F	T	F	F
B	T	F	F	F
C	F	T	F	T
D	F	F	F	F

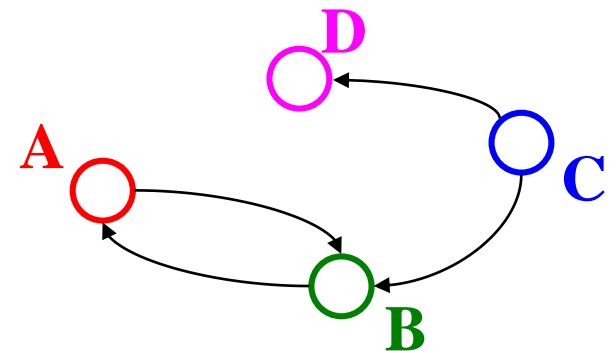

# Adjacency Matrix Properties

- How will the adjacency matrix vary for an *undirected graph*?
- How can we adapt the representation for *weighted graphs*?

	A	B	C	D
A	F	T	F	F
B	T	F	F	F
C	F	T	F	T
D	F	F	F	F

# Adjacency List

- Assign each node a number from 0 to  $|\mathbf{V}| - 1$
- An array of length  $|\mathbf{V}|$  in which each entry stores a list of all adjacent vertices (e.g., linked list)

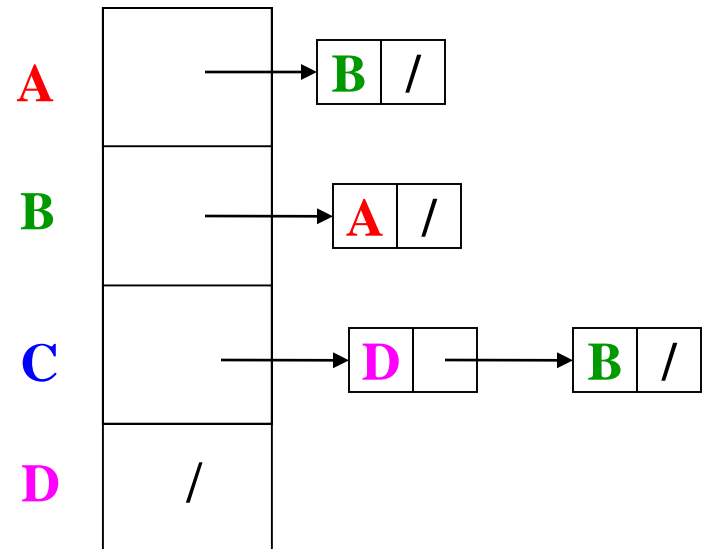
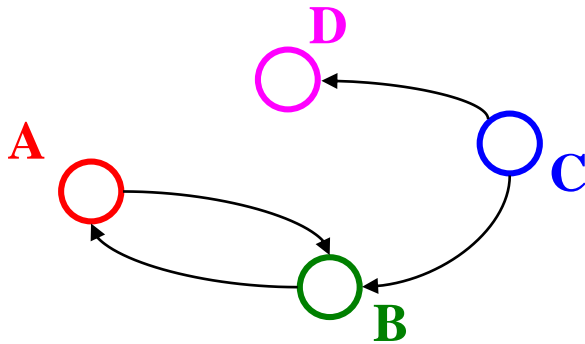

# Adjacency List Properties

- Running time to:
  - Get all of a vertex's out-edges:
  - Get all of a vertex's in-edges:
  - Decide if some edge exists:
  - Insert an edge:
  - Delete an edge:
- Space requirements:
- Best for dense or sparse graphs?

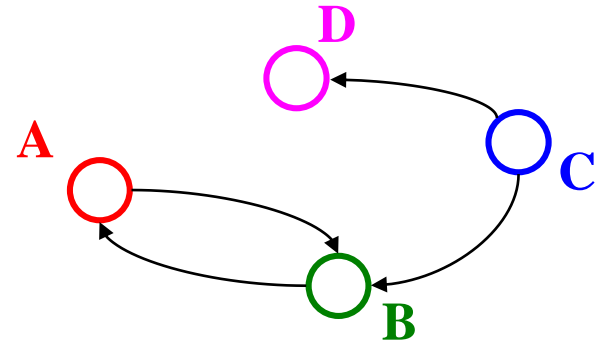
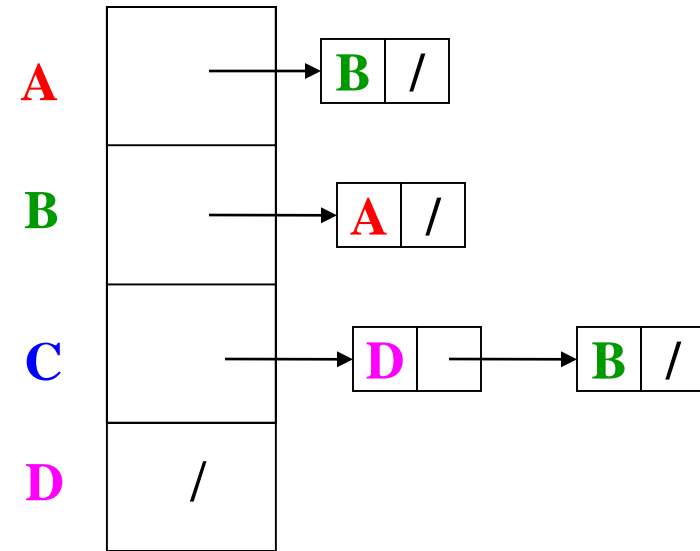

# Undirected Graphs

Adjacency matrices & adjacency lists both do fine for undirected graphs

- Matrix: Can save roughly  $\frac{1}{2}$  the space
  - But may slow down operations in languages with “proper” 2D arrays (not Java, which has only arrays of arrays)
  - How would you “get all neighbors”?
- Lists: Each edge in two lists to support efficient “get all neighbors”

Example:

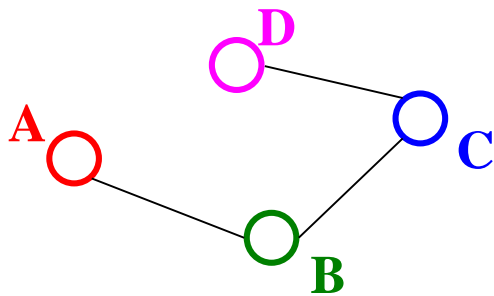

	A	B	C	D
A	F	T	F	F
B	T	F	T	F
C	F	T	F	T
D	F	F	T	F

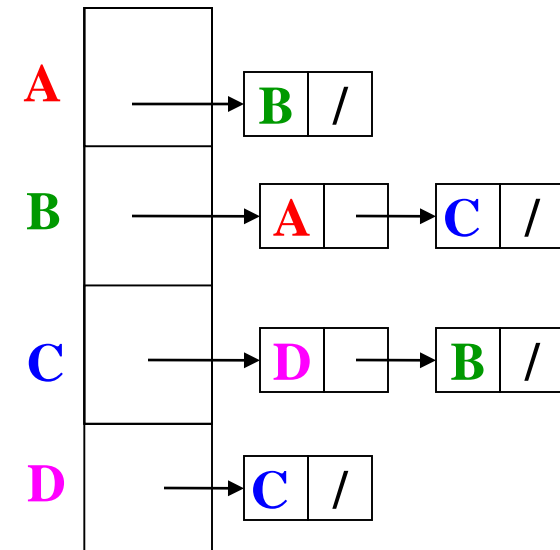

# *Which is better?*

Graphs are often sparse:

- Streets form grids
  - every corner is not connected to every other corner
- Airlines rarely fly to all possible cities
  - or if they do it is to/from a hub rather than directly to/from all small cities to other small cities

Adjacency lists should generally be your default choice

- Slower performance compensated by greater space savings

# Next...

Okay, we can represent graphs

Now let's implement some useful and non-trivial algorithms

- **Topological sort:** Given a DAG, order all the vertices so that every vertex comes before all of its neighbors
- **Shortest paths:** Find the shortest or lowest-cost path from  $x$  to  $y$ 
  - Related: Determine if there even is such a path