



CSE 332: Data Structures & Parallelism

Lecture 25: P, NP, NP-Complete

Richard Jiang

Summer 2020

Agenda (for next 2 lectures)

- A Few Problems:
 - Euler Circuits
 - Hamiltonian Circuits
- Intractability: P and NP
- NP-Complete
- What now?

Try it!

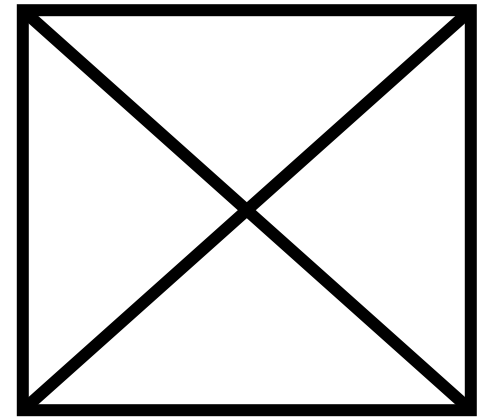
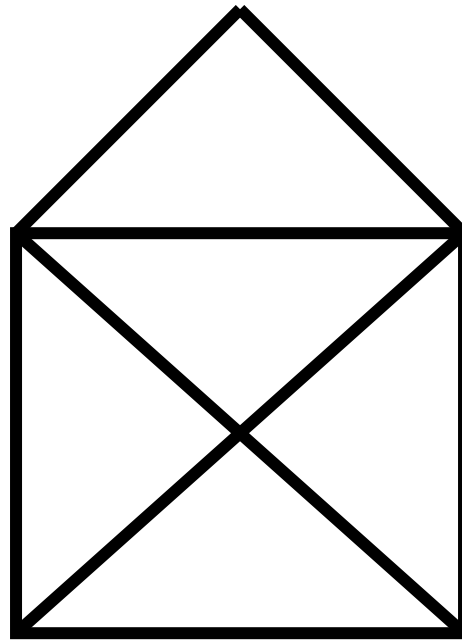
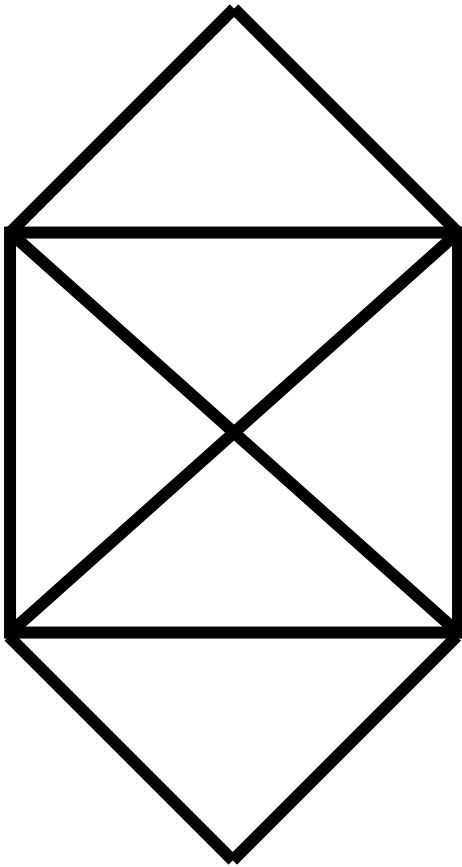

Which of these can you draw (trace all edges) without lifting your pencil, drawing each line only once?

Can you start and end at the same point?

Your First Task

- Your company has to inspect a set of roads between cities by driving over each of them.
- Driving over the roads costs money (fuel), and there are a lot of roads.
- Your boss wants you to figure out how to drive over each road exactly once, returning to your starting point.

Euler Circuits

- Euler circuit: a path through a graph that *visits each edge exactly once and starts and ends at the same vertex*
- Named after Leonhard Euler (1707-1783), who cracked this problem and founded graph theory in 1736
- An Euler circuit exists *iff*
 - the graph is connected and
 - each vertex has **even** degree (= # of edges on the vertex)

The Road Inspector: Finding Euler Circuits

Given a connected, undirected graph $G = (V, E)$, find an Euler circuit in G

Can check if one exists:

- Check if all vertices have even degree

Basic Euler Circuit Algorithm:

1. Do an edge walk from a start vertex until you are back to the start vertex.
 - You never get stuck because of the even degree property.
2. “Remove” the walk, leaving several components each with the even degree property.
 - Recursively find Euler circuits for these.
3. Splice all these circuits into an Euler circuit

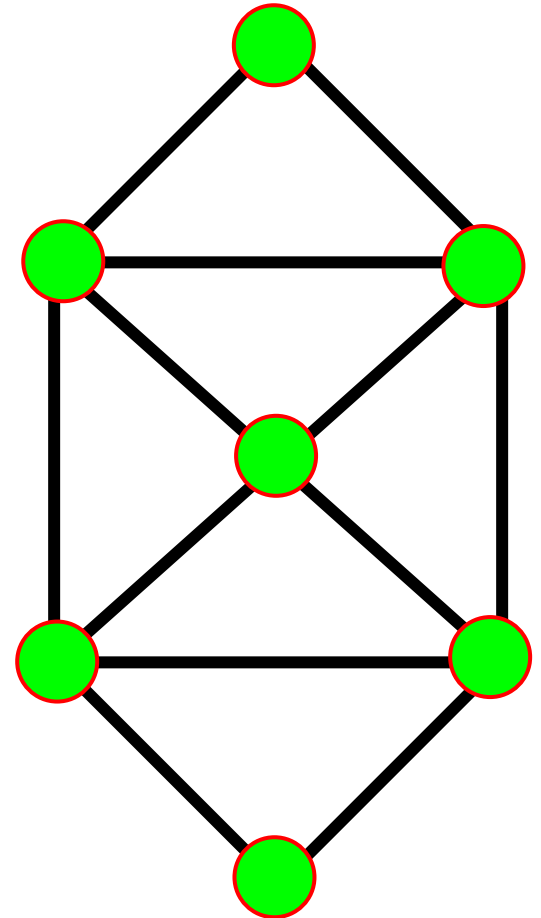

The Road Inspector: Finding Euler Circuits

Given a connected, undirected graph $G = (V, E)$, find an Euler circuit in G

Can check if one exists: (in $O(|V|+|E|)$)

- Check if all vertices have even degree

Basic Euler Circuit Algorithm:

1. Do an edge walk from a start vertex until you are back to the start vertex.
 - You never get stuck because of the even degree property.
2. “Remove” the walk, leaving several components each with the even degree property.
 - Recursively find Euler circuits for these.
3. Splice all these circuits into an Euler circuit

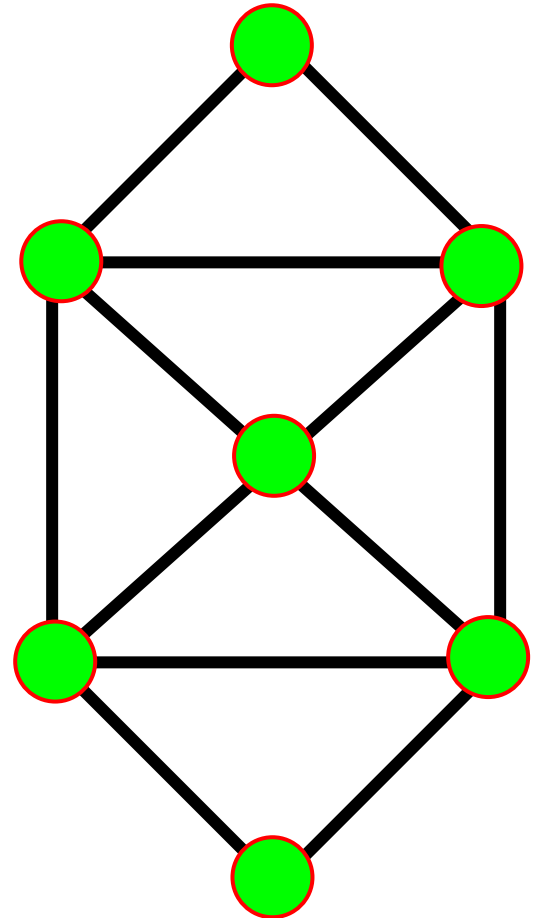

Euler Circuit Example

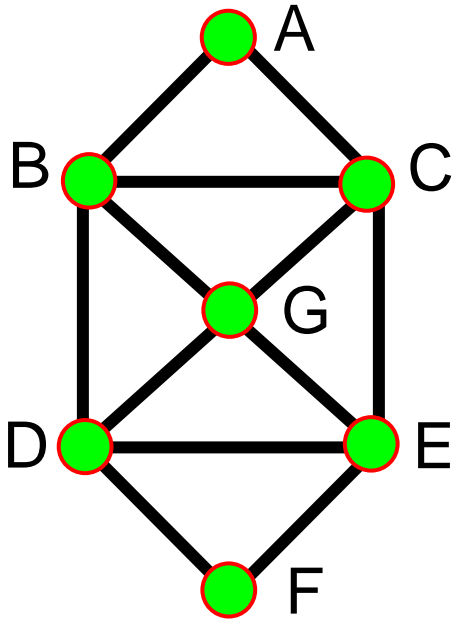

Euler(A) :

Euler Circuit Example

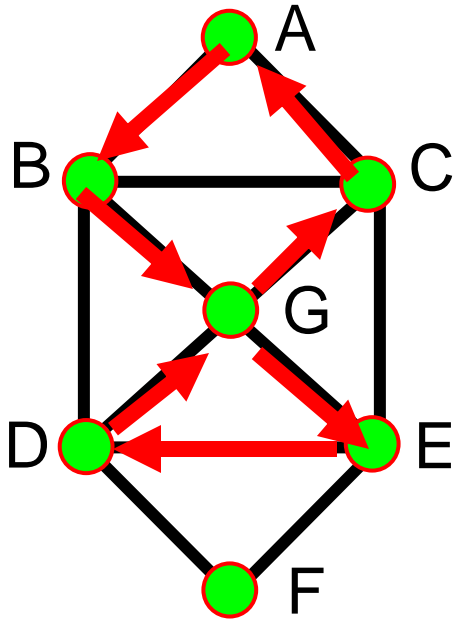

Euler(A) :
A B G E D G C A

Euler Circuit Example

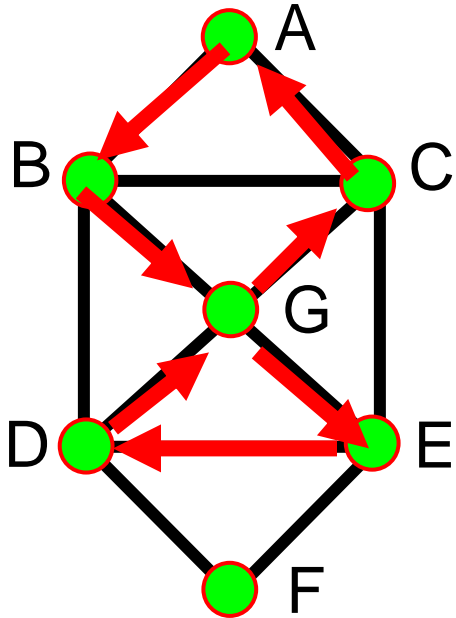

Euler(A) :
A B G E D G C A

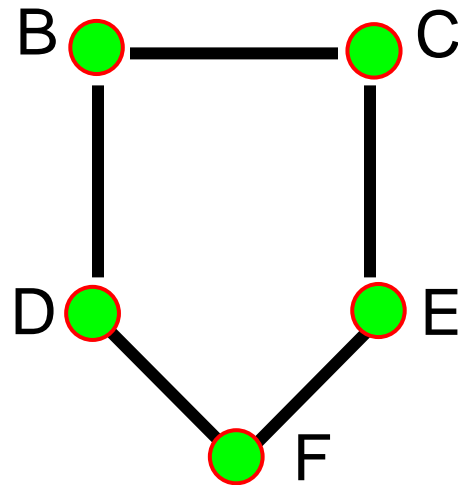

Euler(B)

Euler Circuit Example

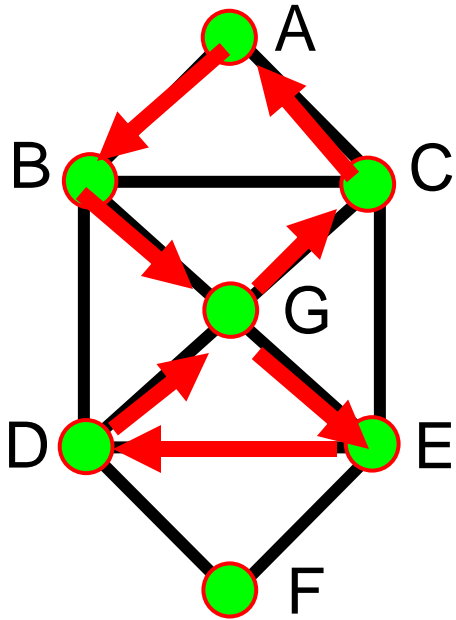

Euler(A) :
A B G E D G C A

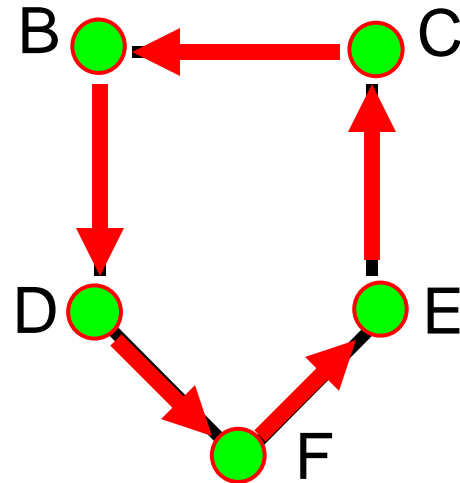

Euler(B):
B D F E C B

Euler Circuit Example

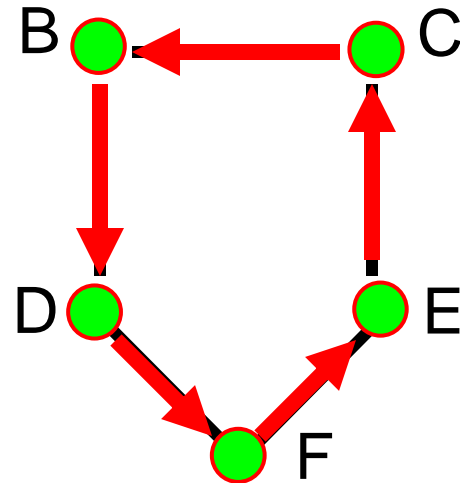
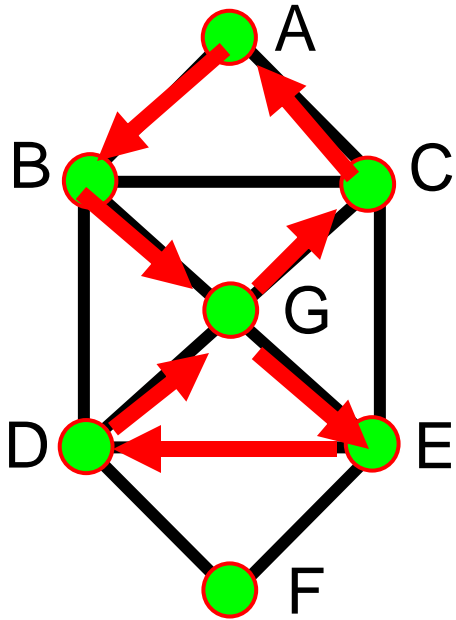

Euler(A) :

A B G E D G C A

Euler(B):

B D F E C B

Splice

12/04/2019 A B D F E C B G E D G C A

Your Second Task

- Your boss is pleased...and assigns you a new task.
- Your company has to send someone by car to a set of cities.
- The primary cost is the exorbitant toll going into each city.
- Your boss wants you to figure out how to drive to each city exactly once, returning in the end to the city of origin.

Hamiltonian Circuits

- **Euler circuit:** A cycle that goes through each *edge* exactly once
- **Hamiltonian circuit:** A cycle that goes through each *vertex* exactly once
- Does graph I have:
 - An Euler circuit?
 - A Hamiltonian circuit?
- Does graph II have:
 - An Euler circuit?
 - A Hamiltonian circuit?
- Which problem sounds harder?

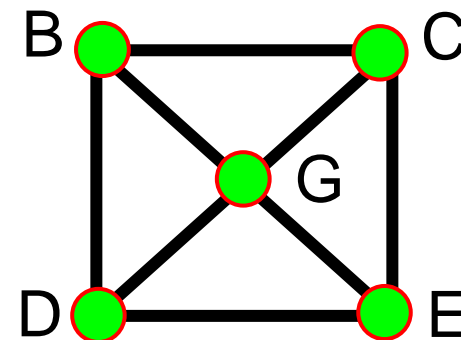
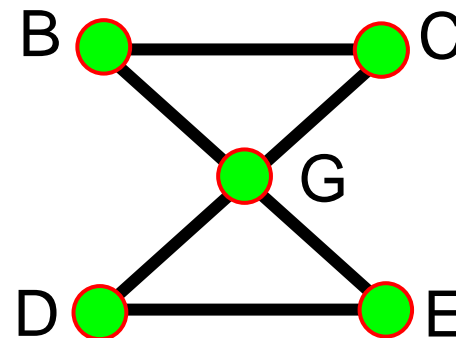

Finding Hamiltonian Circuits

- **Problem:** Find a Hamiltonian circuit in a connected, undirected graph G
- **One solution:** Search through *all paths* to find one that visits each vertex exactly once
 - Can use your favorite graph search algorithm to find paths
- This is an *exhaustive search* (“brute force”) algorithm
- Worst case: need to search all paths
 - **How many paths??**

Running Times

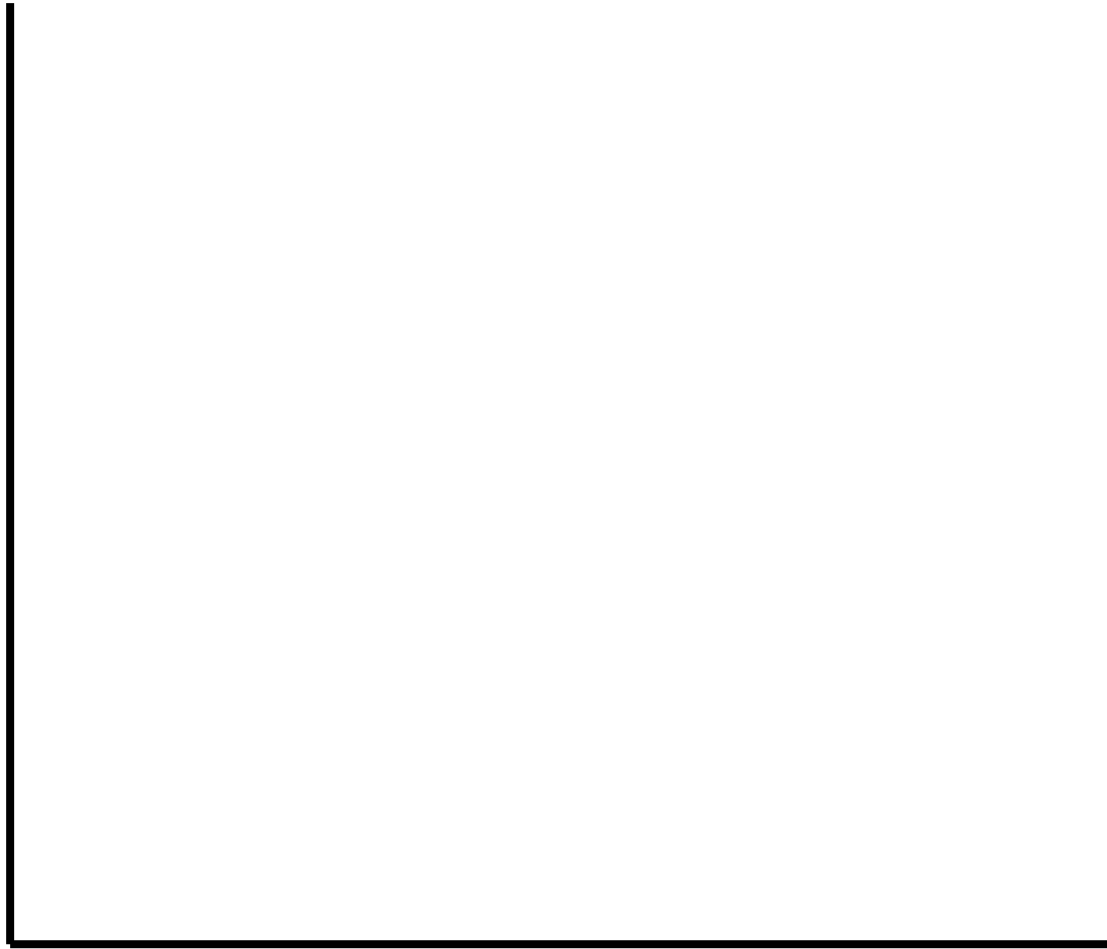

More Running Times

Table 2.1 The running times (rounded up) of different algorithms on inputs of increasing size, for a processor performing a million high-level instructions per second. In cases where the running time exceeds 10^{25} years, we simply record the algorithm as taking a very long time.

	n	$n \log_2 n$	n^2	n^3	1.5^n	2^n	$n!$
$n = 10$	< 1 sec	< 1 sec	< 1 sec	< 1 sec	< 1 sec	< 1 sec	4 sec
$n = 30$	< 1 sec	< 1 sec	< 1 sec	< 1 sec	< 1 sec	18 min	10^{25} years
$n = 50$	< 1 sec	< 1 sec	< 1 sec	< 1 sec	11 min	36 years	very long
$n = 100$	< 1 sec	< 1 sec	< 1 sec	1 sec	12,892 years	10^{17} years	very long
$n = 1,000$	< 1 sec	< 1 sec	1 sec	18 min	very long	very long	very long
$n = 10,000$	< 1 sec	< 1 sec	2 min	12 days	very long	very long	very long
$n = 100,000$	< 1 sec	2 sec	3 hours	32 years	very long	very long	very long
$n = 1,000,000$	1 sec	20 sec	12 days	31,710 years	very long	very long	very long

Somewhat old, from Rosen

Polynomial vs. Exponential Time

- All of the algorithms we have discussed in this class have been **polynomial time** algorithms:
 - Examples: $O(\log N)$, $O(N)$, $O(N \log N)$, $O(N^2)$
 - Algorithms whose running time is $O(N^k)$ for some $k > 0$
- **Exponential time** b^N is asymptotically worse than any polynomial function N^k for any k

The Complexity Class P

- P is the set of all problems that can be solved in *polynomial worst case time*
 - All *problems* that have some *algorithm* whose running time is $O(N^k)$ for some k
- **Examples of problems in P:**
sorting, shortest path, Euler circuit, *etc.*



P

Sorting
Shortest Path
Euler Circuit

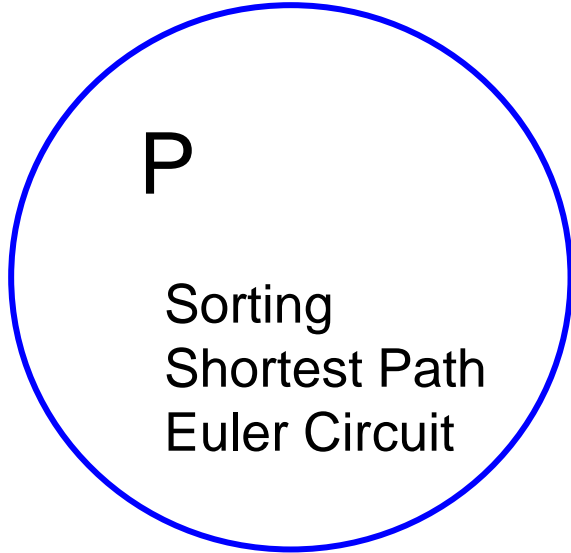

Hamiltonian Circuit

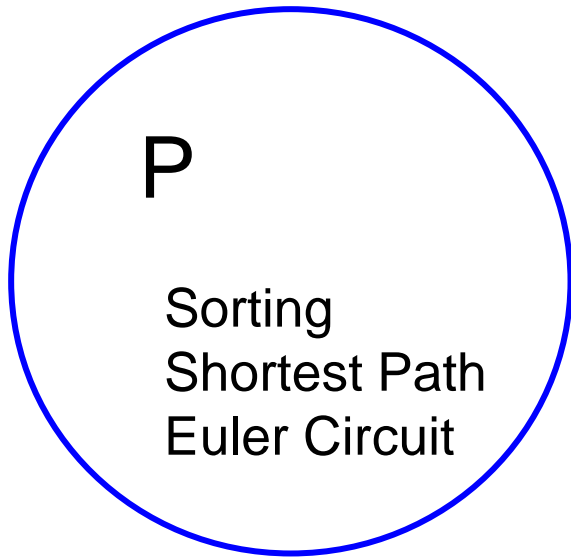

Hamiltonian Circuit
Satisfiability (SAT)
Vertex Cover
Travelling Salesman

Satisfiability

$$(\neg x_1 \vee x_2 \vee x_4) \wedge (x_1 \vee \neg x_3 \vee x_4) \wedge (x_2 \vee \neg x_4 \vee \neg x_5)$$

Input: a logic formula of size **m** containing **n** variables

Output: An assignment of Boolean values to the variables in the formula such that the formula is true

Algorithm: Try every variable assignment

Vertex Cover:

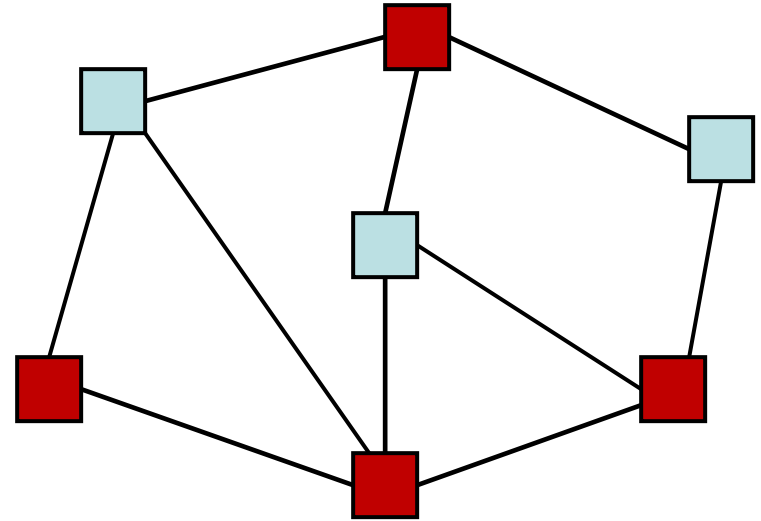

Input: A graph (V, E) and a number m

Output: A subset S of V such that for every edge (u, v) in E , at least one of u or v is in S and $|S|=m$ (if such an S exists)

Algorithm: Try every subset of vertices of size m

Traveling Salesman

Input: A complete *weighted* graph (V, E) and a number m

Output: A circuit that visits each vertex exactly once and has total cost $< m$ if one exists

Algorithm: Try every path, stop if find cheap enough one

A Glimmer of Hope

- If given a candidate solution to a problem, we can **check if that solution is correct in polynomial-time**, then **maybe** a polynomial-time solution exists?
- Can we do this with Hamiltonian Circuit?
 - Given a candidate path, is it a Hamiltonian Circuit?

A Glimmer of Hope

- If given a candidate solution to a problem, we can **check if that solution is correct in polynomial-time**, then maybe a polynomial-time solution exists?
- Can we do this with Hamiltonian Circuit?
 - Given a candidate path, is it a Hamiltonian Circuit? **just check if all vertices are visited exactly once in the candidate path**

The Complexity Class NP

- *Definition*: NP is the set of all problems for which a given *candidate solution* can be *tested* in polynomial time
- Examples of problems in NP:
 - *Hamiltonian circuit*: Given a candidate path, can test in linear time if it is a Hamiltonian circuit
 - *Vertex Cover*: Given a subset of vertices, do they cover all edges?
 - *All problems that are in P* (why?)

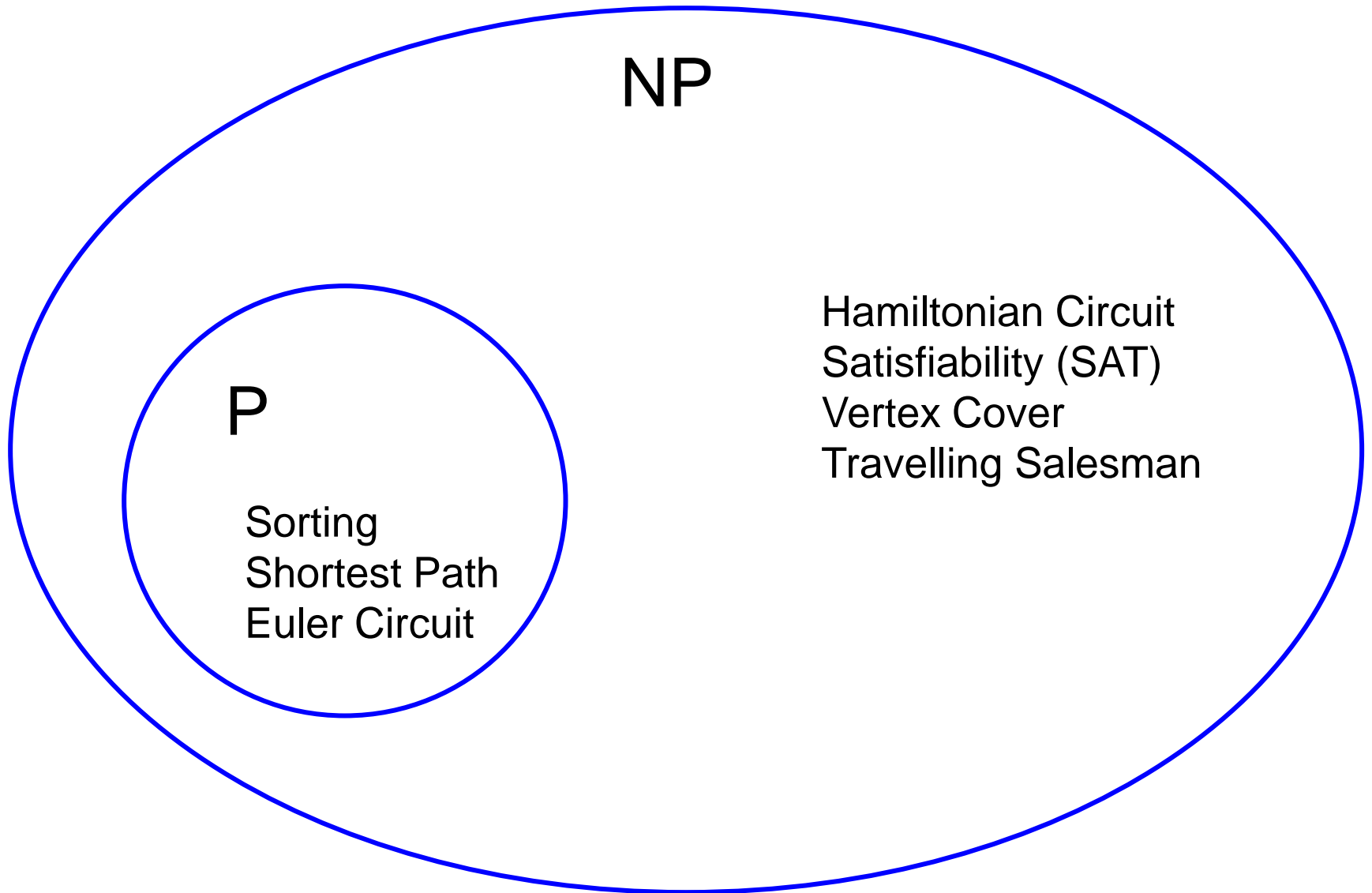

NP

P

Sorting
Shortest Path
Euler Circuit

Hamiltonian Circuit
Satisfiability (SAT)
Vertex Cover
Travelling Salesman

Why do we call it “NP”?

- NP stands for *Nondeterministic Polynomial time*
 - Why “nondeterministic”? Corresponds to algorithms that can guess a solution (if it exists), the solution is then verified to be correct in polynomial time
 - Can also think of as allowing a special operation that allows the algorithm to magically guess the right choice at each branch point.
 - Nondeterministic algorithms don't exist – purely theoretical idea invented to understand how hard a problem could be

Your Chance to Win a Turing Award!

It is generally believed that $P \neq NP$,
i.e. there are problems in NP that are **not** in P

- But no one has been able to show even one such problem!
- This is the fundamental open problem in theoretical computer science
- Nearly everyone has given up trying to prove it. Instead, theoreticians prove theorems about what follows once we assume $P \neq NP$!

NP-completeness

- Set of problems in NP that (we are pretty sure) **cannot** be solved in polynomial time.
- These are thought of as the **hardest** problems in the class NP.
- **Interesting fact:** If any one NP-complete problem could be solved in polynomial time, then **all** NP-complete problems could be solved in polynomial time.
- **Also:** If any NP-complete problem is in P, then all of NP is in P

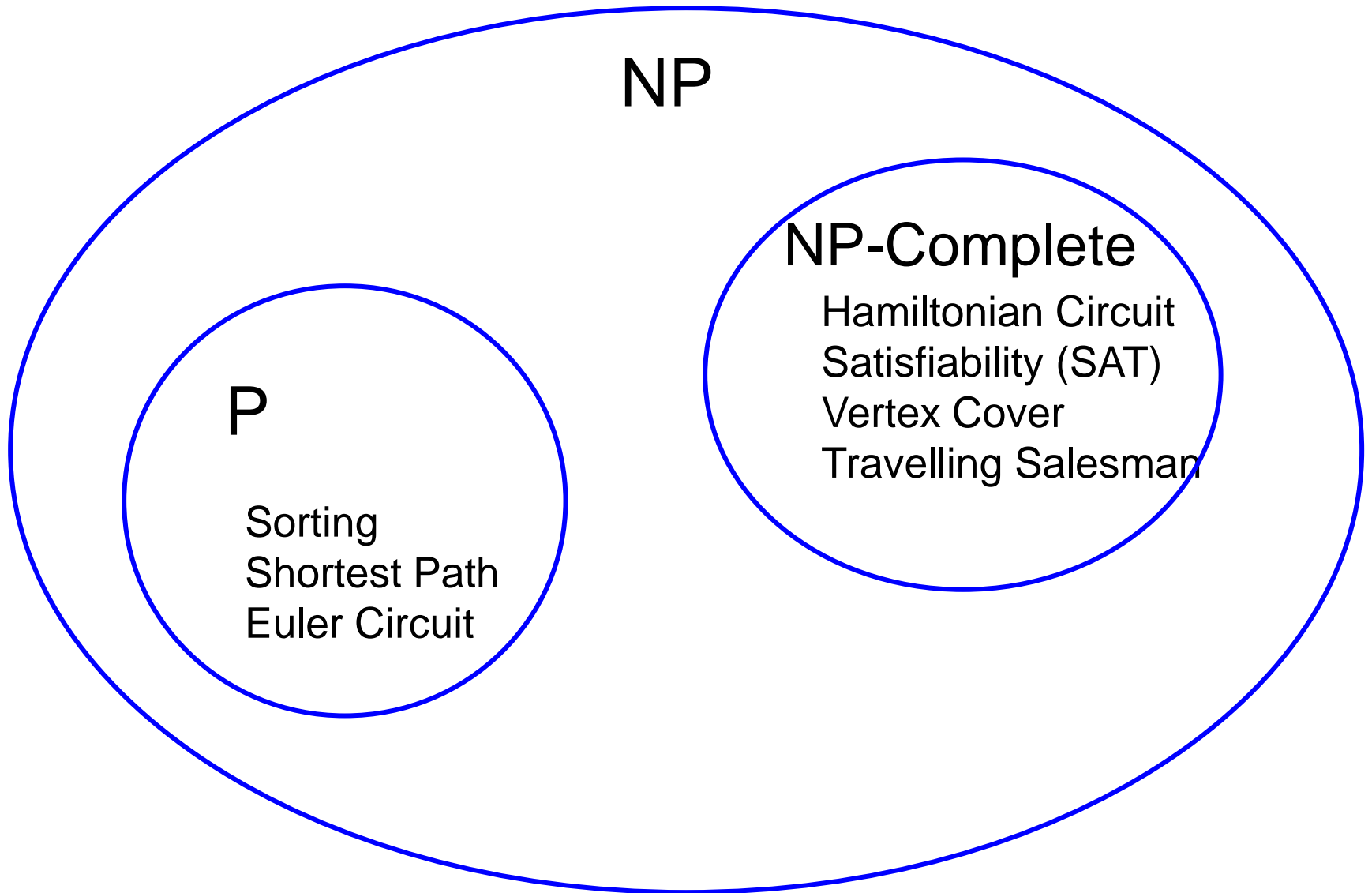

NP

P

Sorting
Shortest Path
Euler Circuit

NP-Complete

Hamiltonian Circuit
Satisfiability (SAT)
Vertex Cover
Travelling Salesman

Saving Your Job

- Try as you might, every solution you come up with for the Hamiltonian Circuit problem runs in exponential time.....
- You have to report back to your boss.
- Your options:
 - Keep working
 - Come up with an alternative plan...

In general, what to do with a Hard Problem

- Your problem seems really hard.
- If you can transform a known NP-complete problem into the one you're trying to solve, then you can stop working on your problem!

Your Third Task

- Your boss buys your story that others couldn't solve the last problem.
- Again, your company has to send someone by car to a set of cities. There is a road between every pair of cities.
- The primary cost is distance traveled (which translates to fuel costs).
- Your boss wants you to figure out how to drive to each city exactly once, then return to the first city, while staying within a fixed mileage budget k .

Travelling Salesman Problem (TSP)

- Your third task is basically TSP:
 - Given complete weighted graph G , integer k .
 - Is there a cycle that visits all vertices with cost $\leq k$?
- One of the canonical problems.
- Note difference from Hamiltonian cycle:
 - graph is complete
 - we care about weight.

Transforming Hamiltonian Cycle to TSP

- We can “reduce” Hamiltonian Cycle to TSP.
- Given graph $G=(V, E)$:
 - Assign weight of 1 to each edge
 - Augment the graph with edges until it is a complete graph $G'=(V, E')$
 - Assign weights of 2 to the new edges
 - Let $k = |V|$.

Notes:

- The transformation must take polynomial time
- You reduce the known NP-complete problem into your problem (not the other way around)
- In this case we are assuming Hamiltonian Cycle is our known NP-complete problem (in reality, both are known NP-complete)

Example

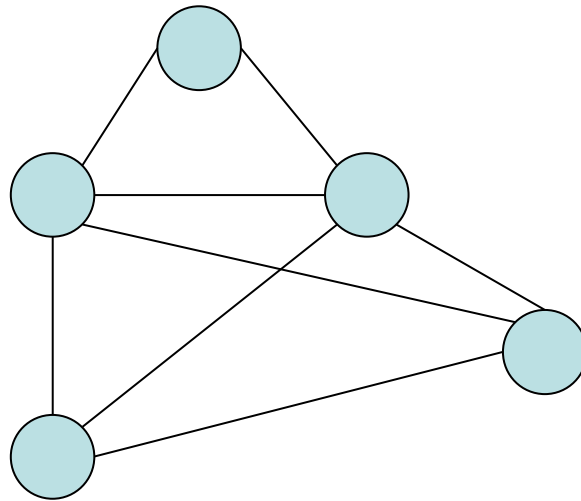

G

Input to Hamiltonian
Circuit Problem

Example

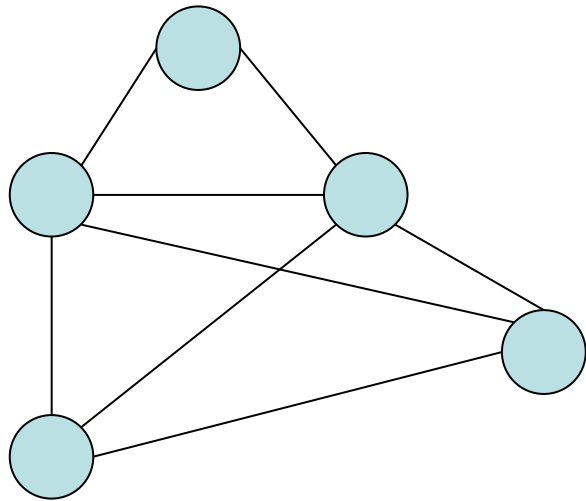

G

Input to Hamiltonian
Circuit Problem



Polynomial time
transformation

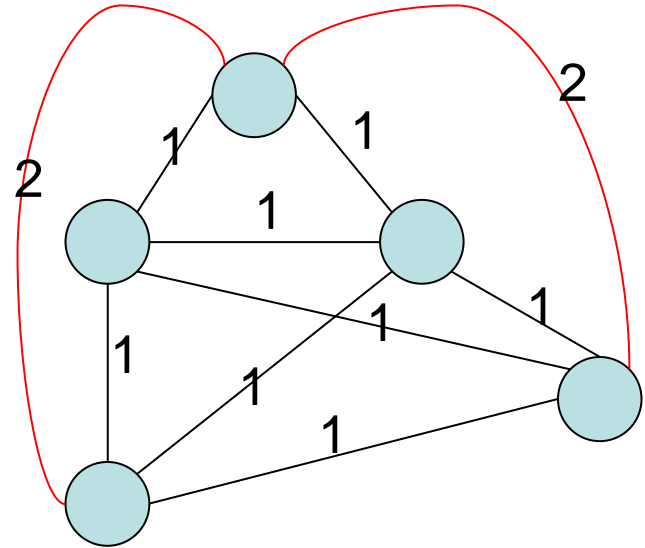

G'

Input to Traveling
Salesman Problem

Polynomial-time transformation

- G' has a TSP tour of weight $|V|$ iff G has a Hamiltonian Cycle.
- What was the cost of transforming HC into TSP?
- In the end, because there is a polynomial time transformation from HC to TSP, we say *TSP* is “at least as hard as” *Hamiltonian cycle*.

Insert Spiderman Meme

- It's not just Ham. Cycle and TSP; A lot of the problems in NP are actually reducible to each other. In fact, all of the hardest problems in NP have been proven to be reducible to each other.
- That means, if we can solve one of the hardest problems in NP in polynomial time, we could solve all of the problems in NP in polynomial time.

Solving Hamiltonian Cycle in polynomial time means we solve 3-SAT in polynomial time!

Or TSP!

Or Integer Programming!



One Last One: NP-Hard

- **NP-Complete:** All of the hardest problems in NP.
- If one NP complete problem is solvable in polynomial time, then all of NP is solvable in polynomial time.
- **NP-Hard:** All of the problems that are at least as hard as the hardest problems in NP.
- If a problem is **NP-hard** and in **NP**, then it is **NP-Complete**.

EXP

NP

NP-Hard

P

NP-Complete

Chess

Halting Prob.

Sorting
Shortest Path
Euler Circuit

Hamiltonian Circuit
Satisfiability (SAT)
Vertex Cover
Travelling Salesman

P=NP?

- If we find a polynomial time algorithm for any NP-complete problem, **we can use this algorithm to generate a polynomial time algorithm for all NP problems**, just like how we did for Hamiltonian and TSP.
- If this were to happen, then NP would collapse into P, meaning that **NP would be equal to P!**

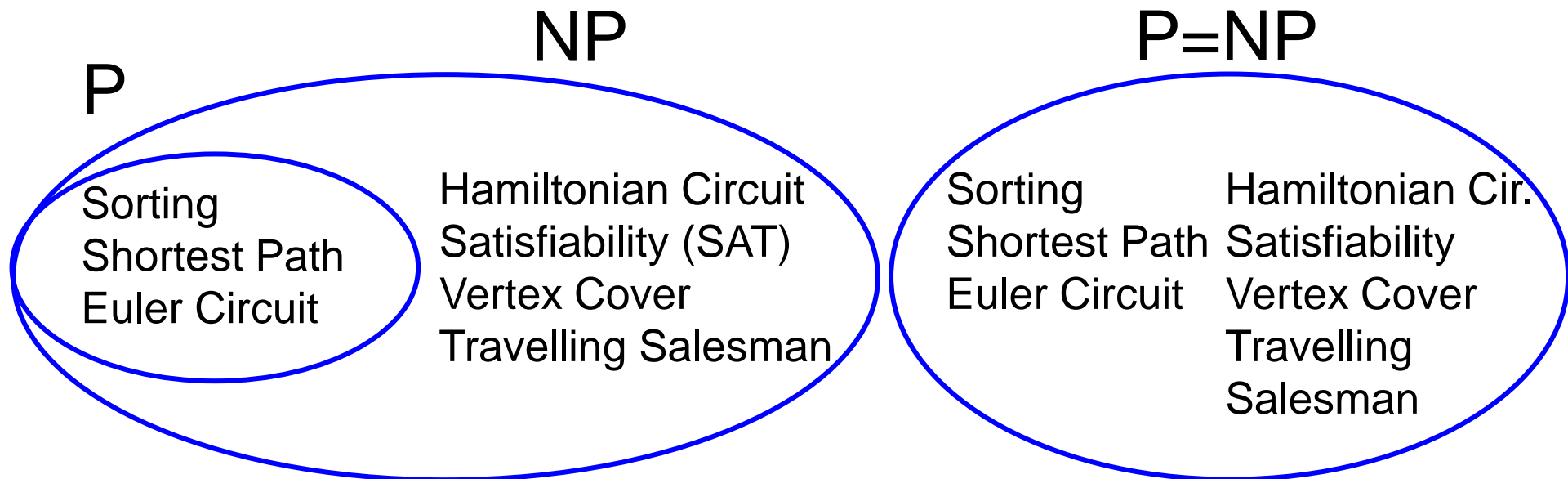

Who Wants to be a Millionaire

- There's a list of problems called the **Millenium Prize Problems**. Solving one of the problems on it wins you one million dollars!
- One of the problems is **P vs. NP: Does $P = NP$?**
- This problem has been around for a very, very, **very** long time and no one has solved it yet.
- $P = NP$ is about proving that “If something is easy to verify, then it's also easy to solve.”

If $P=NP$

- Traveling Salesman is easy! -> Drone pathing for Amazon is easy!
- Integer factorization is easy! -> RSA is easy to solve! -> Cryptography is busted!
- In theory, Cryptography is about having a problem that is **easy to verify** (check that the key fits), but **hard to crack** (create a new key from scratch).
- $P = NP$ -> Cryptography doesn't exist!
- Next Lecture: How to rob a bank if $P = NP$ (jk)

But $P \neq NP$, Probably

- No one really thinks $P = NP$.
- We've started assuming that $P \neq NP$ and proving things based on that.
- We've come up with new cryptography algorithms that don't rely on $P \neq NP$.
- **But if you still want a million dollars, a proof that shows that $P \neq NP$ will still win you the Millenium Prize.**

What do we do about it?

- Approximation Algorithm:
 - Can we get an efficient algorithm that guarantees something *close* to optimal? (e.g. Answer is guaranteed to be within 1.5x of Optimal, but solved in polynomial time).
- Restrictions:
 - Many hard problems are easy for restricted inputs (e.g. graph is always a tree, degree of vertices is always 3 or less).
- Heuristics:
 - Can we get something that seems to work well (good approximation/fast enough) *most* of the time? (e.g. In practice, n is small-ish)

Intro to Complexity

- Complexity isn't just about $P = NP$.
 - It's about discovering the limits of computers. (Halting Problem)
- It's about finding out how efficiently we can solve problems...
 - In time... (Is problem X in P ? In NP ? In LOG ? In EXP ?)
 - In space... ($PSPACE$? $LOGSPACE$? Almost- $PSPACE$?)
 - And in a few cases, about what's easier: Verifying or solving. (P vs. NP ? EXP vs. $NEXP$?)
- (Take 431 for more!)