

CSE 332

Data Abstractions

Graphs 3: Single-Source Shortest Paths

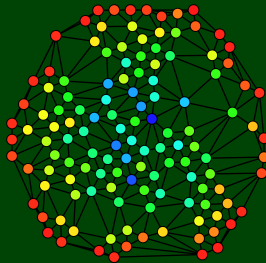

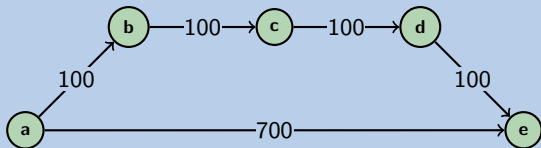

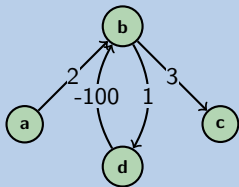
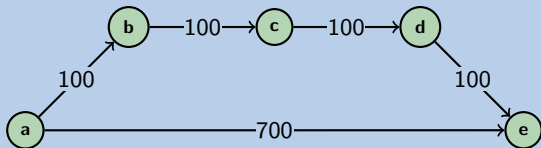

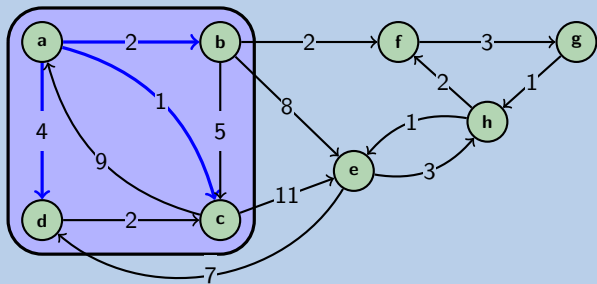

- Initially, start node has cost 0 and all other nodes have cost ∞
- At each step...
 - Try to expand the paths one more edge
 - Add vertices to the worklist
 - Update estimated distances
- We're done!

worklist ←

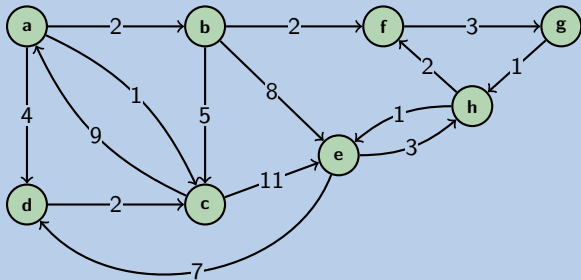

worklist ←

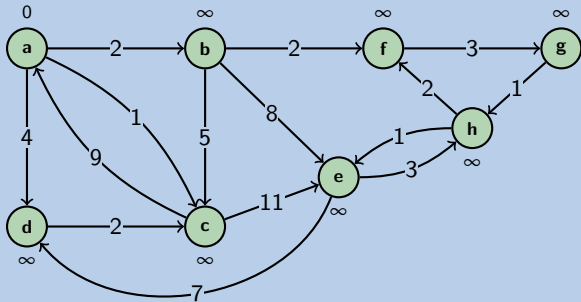

worklist ← $a \leq 0$ ←

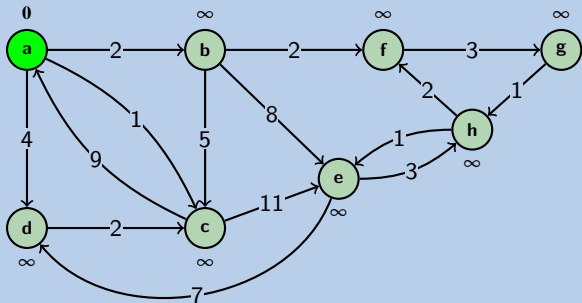

worklist ←

| | | |
|------------|------------|------------|
| $c \leq 1$ | $b \leq 2$ | $d \leq 4$ |
|------------|------------|------------|

 ←

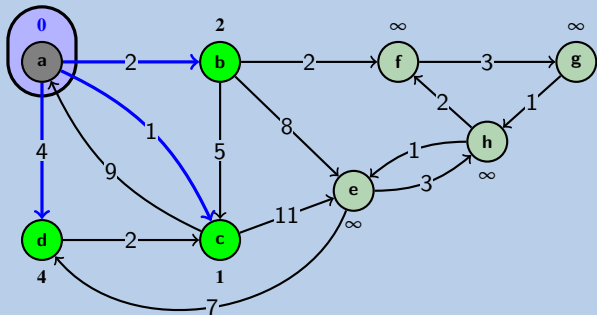

worklist ←

| | |
|------------|------------|
| $b \leq 2$ | $d \leq 4$ |
|------------|------------|

 ←

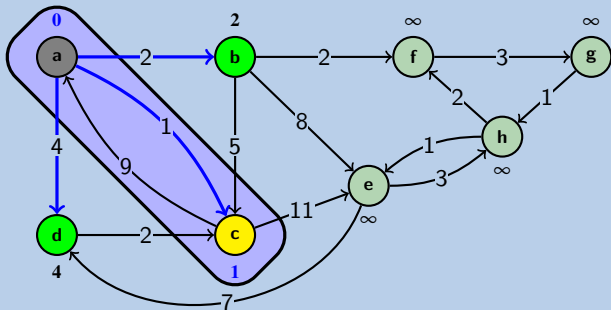

worklist ←

| | | |
|------------|------------|-------------|
| $b \leq 2$ | $d \leq 4$ | $e \leq 12$ |
|------------|------------|-------------|

 ←

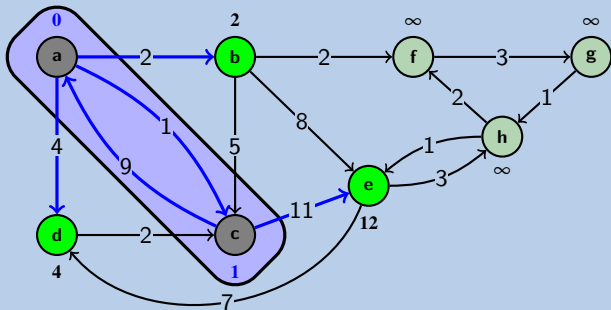

worklist ←

| | |
|------------|-------------|
| $d \leq 4$ | $e \leq 12$ |
|------------|-------------|

 ←

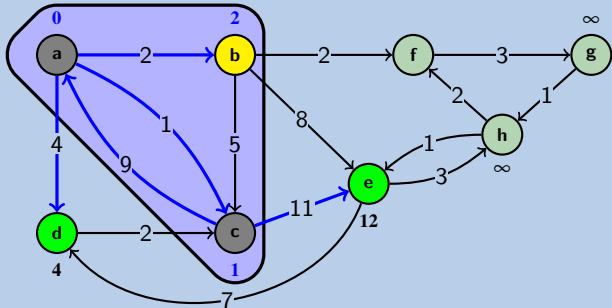

worklist ←

| | | |
|------------|------------|-------------|
| $d \leq 4$ | $f \leq 4$ | $e \leq 10$ |
|------------|------------|-------------|

 ←

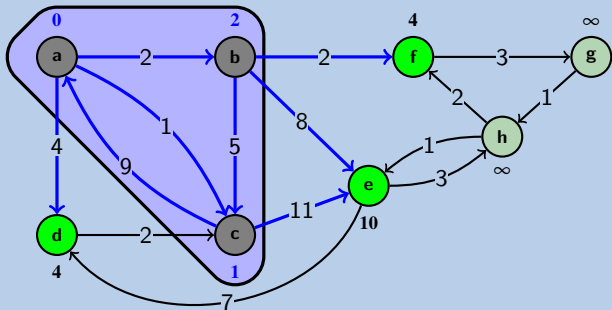

worklist ← $f \leq 4$ $e \leq 10$ ←

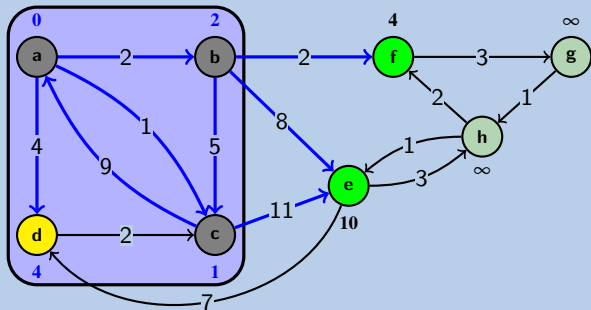

worklist ← $f \leq 4$ $e \leq 10$ ←

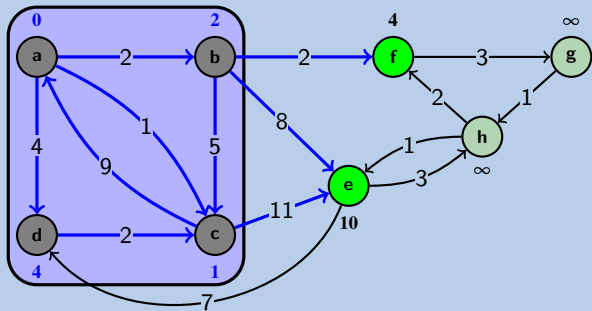

worklist ← $e \leq 10$ ←

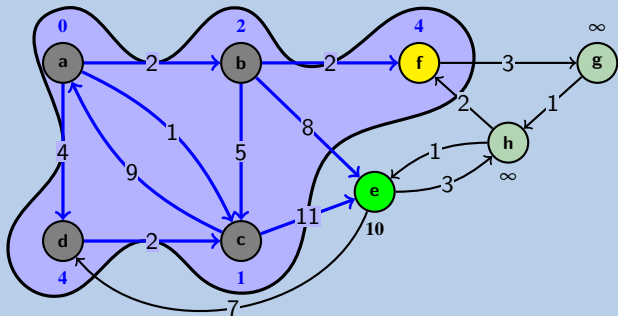

worklist ← $g \leq 7$ $e \leq 10$ ←

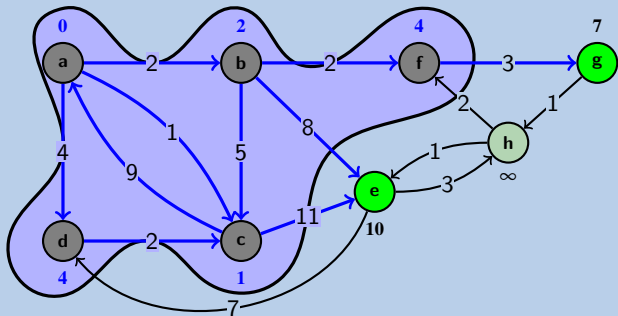

worklist ← $e \leq 10$ ←

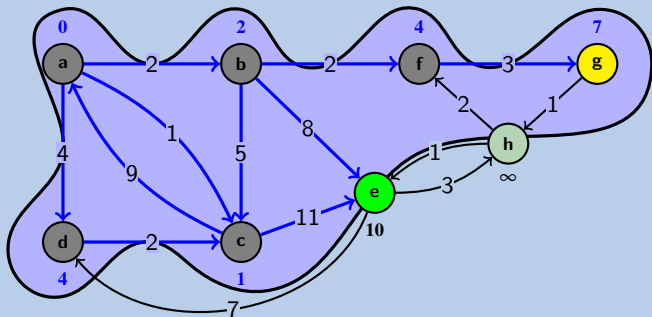

worklist ←

| | |
|------------|-------------|
| $h \leq 8$ | $e \leq 10$ |
|------------|-------------|

 ←

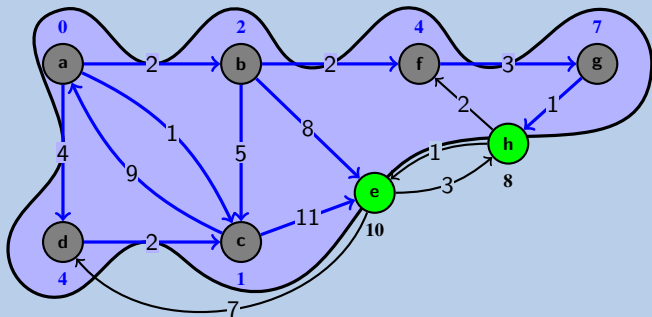

worklist ← $e \leq 10$ ←

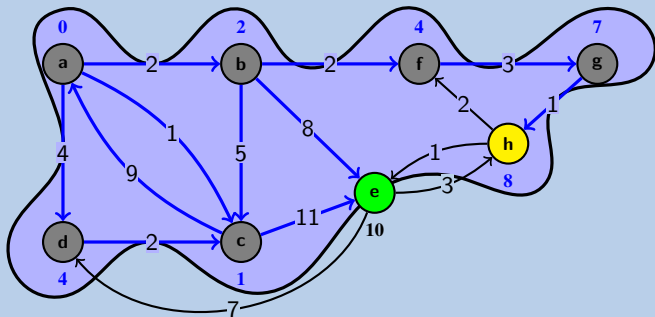

worklist ← $e \leq 9$ ←

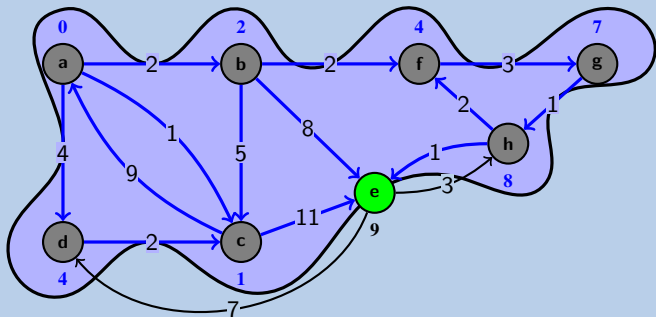

worklist ←

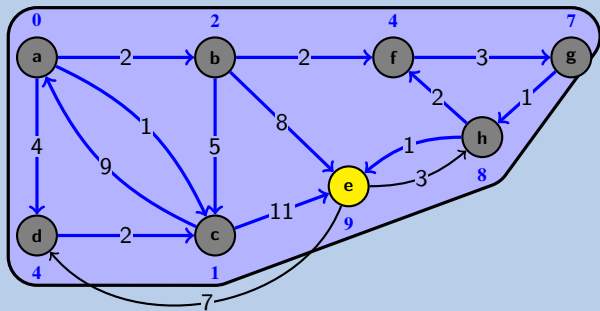

worklist ←

