

Final Exam Practice Questions Solutions

NFA Construction

Draw the state diagram of an NFA  $M$  that recognizes the language  $a^*b(b \cup ab)^*a$  over  $\Sigma = \{a, b\}$ . Try to avoid unnecessary states.

Solution:

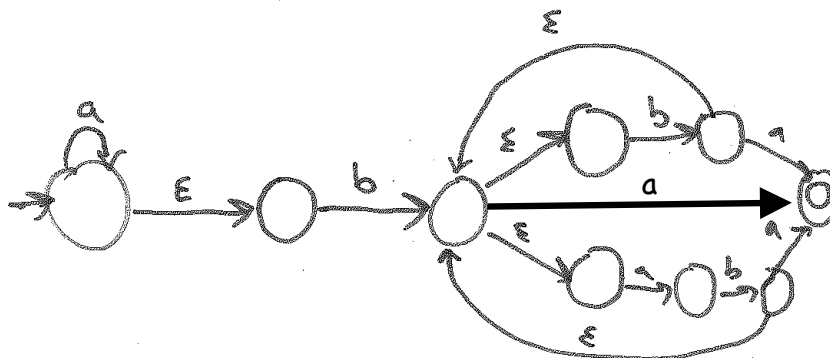

Powerset Construction

Build a DFA equivalent to the following NFA using the powerset construction. You only need to show states that are reachable from the start state of your DFA (but do not simplify further).

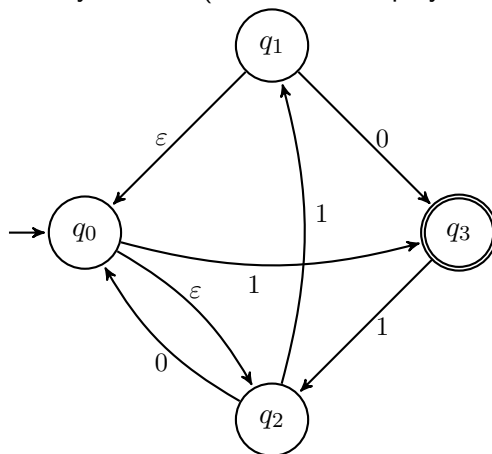

Solution:

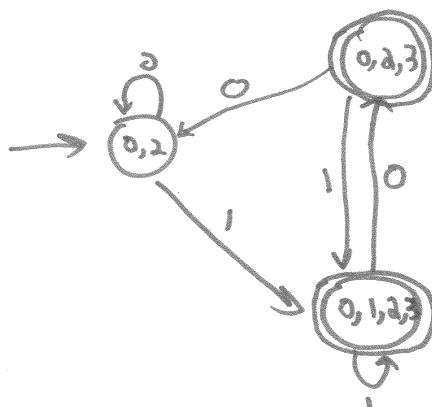

## DFA, Regexp, CFG

For each of the following languages, construct a DFA, Regular Expression, and CFG for it.

(a)  $A = \{w \in \{0,1\}^* : \text{the number of 0's minus the number of 1's in } w \text{ is divisible by 3}\}$ .

**Solution:**

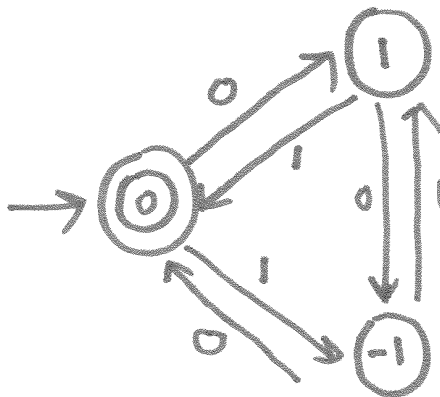

$$(((0 \cup (11))(01)^*((00) \cup 1)) \cup (10))^*$$

$$S \rightarrow 0A \mid 1B \mid \varepsilon$$

$$A \rightarrow 0B \mid 1S$$

$$B \rightarrow 0S \mid 1A$$

(b)  $B = \{w \in \{a,b\}^* : \text{every } a \text{ has two } b\text{'s immediately to its right}\}$ .

**Solution:**

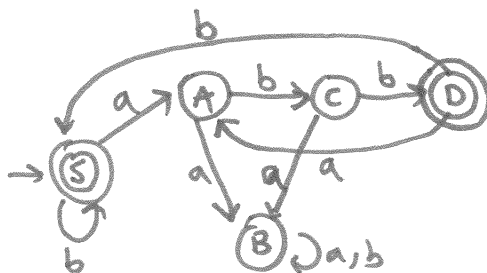

$$(b^*(abb)^*b^*)^*$$

$$S \rightarrow aA \mid bS \mid \varepsilon$$

$$A \rightarrow aB \mid bC$$

$$B \rightarrow B$$

$$C \rightarrow aB \mid bD$$

$$D \rightarrow aA \mid bS \mid \varepsilon$$

## Context-Free & Irregular

Consider the language  $C = \{a^n b a^m b a^{m+n} : n, m \geq 1\}$ .

(a) Show that  $C$  is context-free.

**Solution:**

$$\begin{aligned} S &\rightarrow aXa \\ X &\rightarrow aXa \mid baYa \\ Y &\rightarrow aYa \mid b \end{aligned}$$

(b) Show that  $C$  is not regular.

**Solution:**

Suppose for contradiction that  $C$  is regular. Then, there is an FSM  $M$  that accepts it. Consider the set of strings  $S = \{a^n b a b : n \geq 1\}$ . Then, since  $S$  is infinite and  $M$  only has a finite number of states, two strings  $a^i b a b \in S$  and  $a^j b a b \in S$ , where  $i \neq j$  end in the same state in  $M$ . Consider appending  $a^{i+1}$  to both strings:

- $a^i b a b a^{i+1}$  should be accepted, because  $i + 1 = i + 1$ .
- $a^j b a b a^{i+1}$  should not be accepted, because  $j + 1 \neq i + 1$  (since  $i \neq j$ ).

However, these two strings must end in the same state. So, it follows that  $M$  does not accept  $C$  which is a contradiction. So,  $C$  is not regular.

## Recursive Definitions & Strong Induction

(a) In the land of Garbanzo, the unit of currency is the bean. They only have two coins, one worth 2 beans and the other worth 5 beans.

(a) Give a recursive definition of the set of positive integers  $S$  such that  $x \in S$  iff one can make up an amount worth  $x$  beans using at most one 5-bean coin and any number of 2-bean coins.

**Solution:**

- $2 \in S$
- $5 \in S$
- If  $x \in S$ , then  $x + 2 \in S$

(b) Prove by strong induction that if  $n \geq 4$ , then  $n \in S$ .

**Solution:**

We go by strong induction to show for all  $n \geq 4$ ,  $n \in S$ .

**Base Cases:**

- $2 \in S \Rightarrow 2 + 2 \in S \Rightarrow 4 \in S$
- $5 \in S$

**Induction Hypothesis:** Suppose that  $4 \in S$ ,  $5 \in S$ ,  $\dots$ ,  $k \in S$  for some  $k \geq 5$ .

**Induction Step:** We show that  $k+1 \in S$ . Consider  $(k+1) - 2$ . Since  $(k+1) - 2 = k - 1 \geq 5 - 1 = 4$ , we already know  $k - 1 \in S$  by our IH. Then, note that  $k - 1 \in S \Rightarrow (k - 1) + 2 \in S \Rightarrow k + 1 \in S$  by definition of  $S$ . So, the claim is true for  $k + 1$ .

Thus, we have shown by strong induction that  $x \in S$  for all  $x \geq 4$ .

(b) Define  $g(n)$  as follows:

$$g(n+1) = \begin{cases} 0 & \text{if } n = 0 \\ \max_{1 \leq k \leq n} g(k) + g(n+1-k) + 1 & \text{otherwise} \end{cases}$$

Prove by induction that  $g(n) = n - 1$  for all  $n \geq 1$ .

**Solution:**

We go by strong induction to show for all  $n \geq 1$ ,  $g(n) = n - 1$ .

**Base Case:**

- By definition of  $g(1)$ , we have  $g(1) = 0 = 1 - 1$ .

**Induction Hypothesis:** Suppose that  $g(1) = 1 - 1$ ,  $g(2) = 2 - 1$ ,  $\dots$ ,  $g(k) = k - 1$  for some  $k \geq 1$ .

**Induction Step:** We show that  $g(k+1) = (k+1) - 1$ .

Note that  $k+1 \geq 1+1 \geq 2$ ; so, we can use the second part of the definition of  $g(n)$  for  $k+1$ . In particular, we know  $g(k+1) = \max_{1 \leq \ell \leq k} g(\ell) + g((k+1) - \ell) + 1$ . Note that by our IH, we can replace the inside of the max with the closed form. That is,  $g(k+1) = \max_{1 \leq \ell \leq k} (\ell - 1) + (k+1 - \ell - 1) + 1$  by IH. Simplifying, we see that  $g(k+1) = \max_{1 \leq \ell \leq k+1} (k+1) - 1 = k$  as required.

Thus, we have shown by strong induction that  $g(n) = n - 1$  for all  $n \geq 1$ .

**Relation Closures**

Let  $R$  be the relation  $\{(1, 2), (3, 4), (1, 3), (2, 1)\}$  defined on the set  $\{1, 2, 3, 4, 5\}$ .

(a) Draw the graph of  $R$ .

**Solution:**

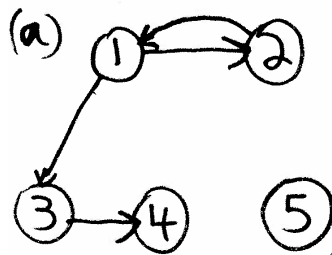

(b) Draw the graph of the  $R^2$ .

**Solution:**

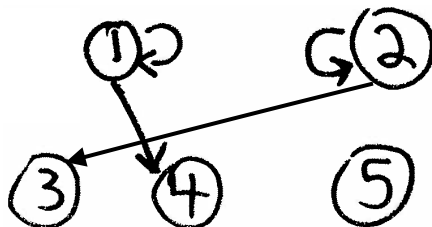

(c) Draw the graph of the reflexive-transitive closure of  $R$ .

**Solution:**

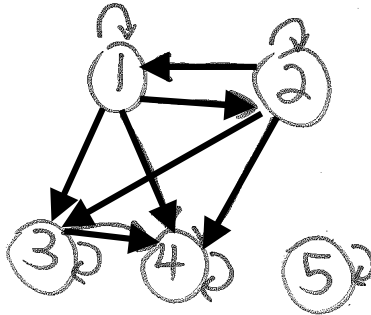

## Relations Proofs

Suppose  $R_1$  and  $R_2$  are reflexive relations on a set  $A$ . Is the relation  $R_1 \cup R_2$  necessarily a reflexive relation? Justify your answer.

**Solution:**

Yes. We show that  $\forall(x \in A) (x, x) \in R_1 \cup R_2$ . Let  $x \in A$  be arbitrary. Note that, since  $R_1$  is reflexive,  $(x, x) \in R_1$ . Thus,  $(x, x) \in R_1 \cup R_2$  by definition of union.

## True or False

For each of the following answer True or False and give a short (1-2 sentence) explanation of your answer.

- (a) 

True or False	The set $\{(\text{CODE}(R), x) : R \text{ halts when given } x\}$ is decidable.
---------------	---

**Solution:**

This set is undecidable by Rice's Theorem. We can write a program "return true" and another program "while (true)" such that the first program on any input will be in the set and the second will not.

- (b) 

True or False	The set $\{\text{CODE}(Q) : Q \text{ reads input}\}$ is decidable.
---------------	--

**Solution:**

This set is undecidable by Rice's Theorem. We can write a program "read input" and another program "return true" such that the first program on any input will be in the set and the second will not.

## DFA Minimization

Minimize the following DFA using the algorithm we discussed in lecture:

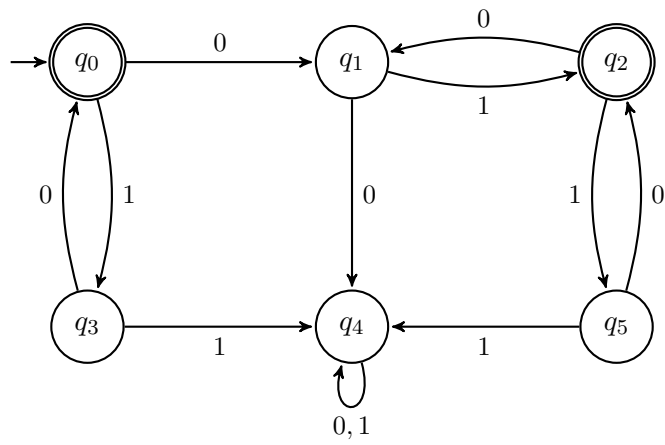

Solution:

