

LEC 15

CSE 121

2D Arrays

Questions during Class?

Raise hand or send here

sli.do #cse121



BEFORE WE START

Talk to your neighbors:

*What computer application (website, app)
do you use the most on a daily basis?*

Music:  [CSE 121 26sp Lecture Tunes](#) 

Instructors: Matt Wang

TAs:	Abdul	Amogh	Anant	Anum	Cayden
	Dalton	Ethan	Hayden	Jesse	Jessica
	Johnathan	Minh	Navya	Paul	Reese
	Ruslana	Sam	Savannah	Spencer	Shayna
	Tamsyn	TJ	Trey		

Announcements, Reminders

- C3 released, due **Tuesday, May 26th**
- R5 due next **Thursday, May 28th** (eligible: **P1**, C2, P2)
 - P1 cycling out of eligibility after R5
- Quiz 2 on **Thursday, May 28th**
 - can't make it? email Matt *before* your quiz!
 - [Quiz 2 Practice Resources](#) out! (including some explanations)
(practice quiz keys out Sunday)
- Reminder: final exam on **Wednesday, June 10th, 2:30 – 4:20 PM**



Practice: Think

[sli.do](#)[#cse121](#)

```
public static void main(String[] args) {
    int x = 0;
    int[] a = new int[4];
    x++;

    mystery(x, a);
    System.out.println(x + " " + Arrays.toString(a));

    x++;
    mystery(x, a);
    System.out.println(x + " " + Arrays.toString(a));
}

public static void mystery(int x, int[] a) {
    x++;
    a[x]++;
    System.out.println(x + " " + Arrays.toString(a));
}
```

Four lines of output are produced by this code. What would those four lines be?



Practice: Pair

sli.do

#cse121

```
public static void main(String[] args) {  
    int x = 0;  
    int[] a = new int[4];  
    x++;  
  
    mystery(x, a);  
    System.out.println(x + " " + Arrays.toString(a));  
  
    x++;  
    mystery(x, a);  
    System.out.println(x + " " + Arrays.toString(a));  
}  
  
public static void mystery(int x, int[] a) {  
    x++;  
    a[x]++;  
    System.out.println(x + " " + Arrays.toString(a));  
}
```

Four lines of output are produced by this code. What would those four lines be?



Practice: Think



sli.do

#cse121

```
public static void main(String[] args) {  
    → int x = 0;  
    → int[] a = new int[4];  
    x++;  
  
    mystery(x, a);  
    System.out.println(x + " " + Arrays.toString(a));  
  
    x++;  
    mystery(x, a);  
    System.out.println(x + " " + Arrays.toString(a));  
}
```

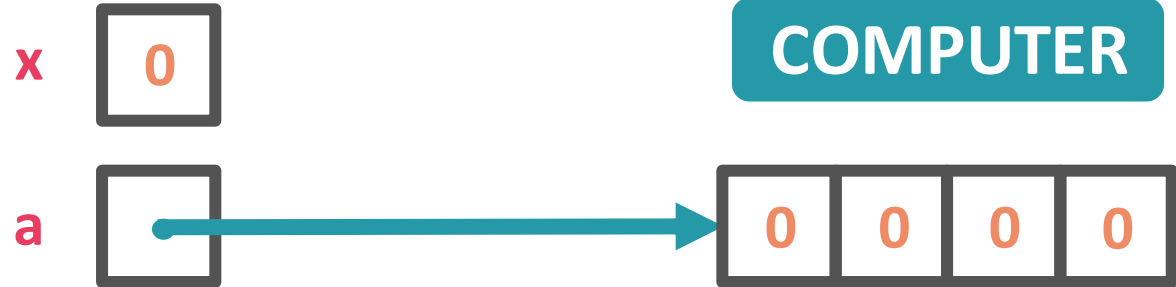

```
public static void mystery(int x, int[] a) {  
    x++;  
    a[x]++;  
    System.out.println(x + " " + Arrays.toString(a));  
}
```



Practice: Think



sli.do #cse121

```

public static void main(String[] args) {
    int x = 0;
    int[] a = new int[4];
    x++;
    mystery(x, a);
    System.out.println(x + " " + Arrays.toString(a));

    x++;
    mystery(x, a);
    System.out.println(x + " " + Arrays.toString(a));
}

```

```

public static void mystery(int x, int[] a) {
    x++;
    a[x]++;
    System.out.println(x + " " + Arrays.toString(a));
}

```

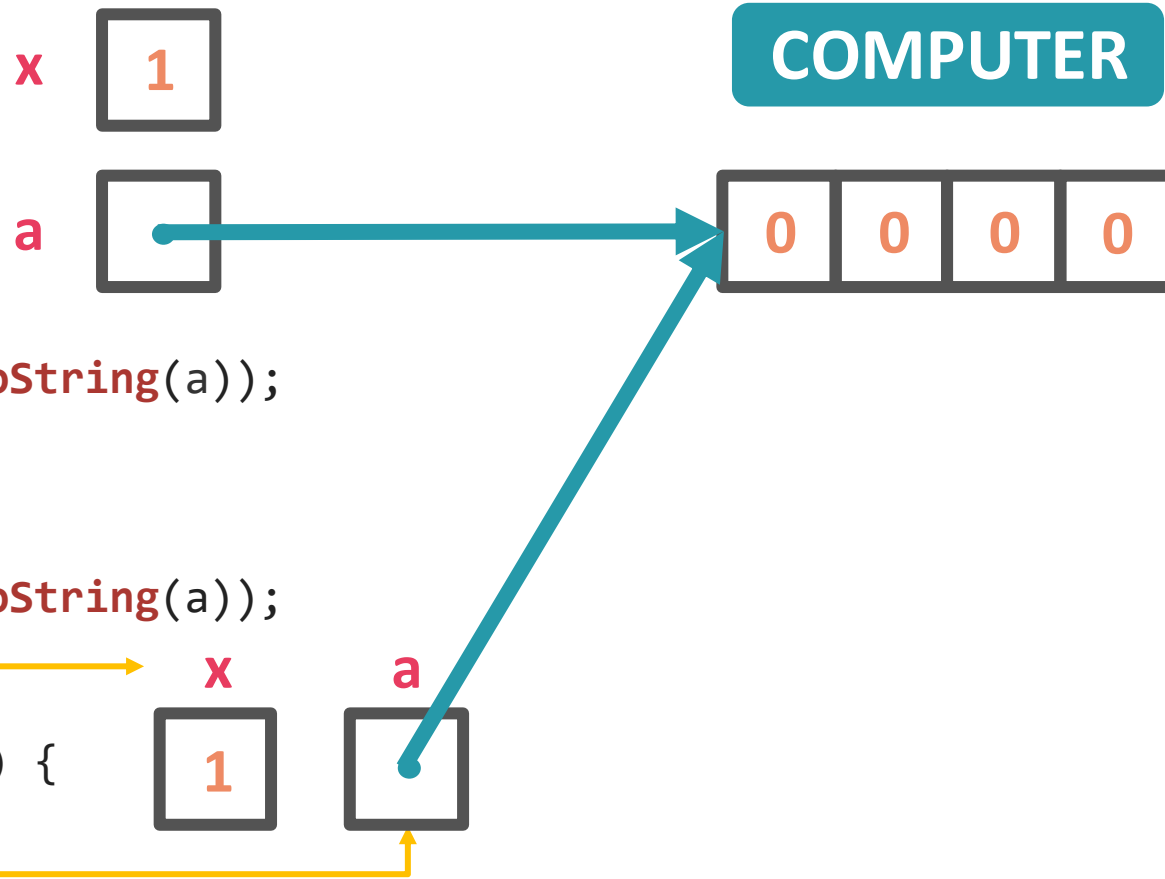



Practice: Think



slido #cse121

```

public static void main(String[] args) {
    int x = 0;
    int[] a = new int[4];
    x++;

    mystery(x, a);
    System.out.println(x + " " + Arrays.toString(a));

    x++;
    mystery(x, a);
    System.out.println(x + " " + Arrays.toString(a));
}

```

```

public static void mystery(int x, int[] a) {
    x++;
    a[x]++;
    System.out.println(x + " " + Arrays.toString(a));
}

```

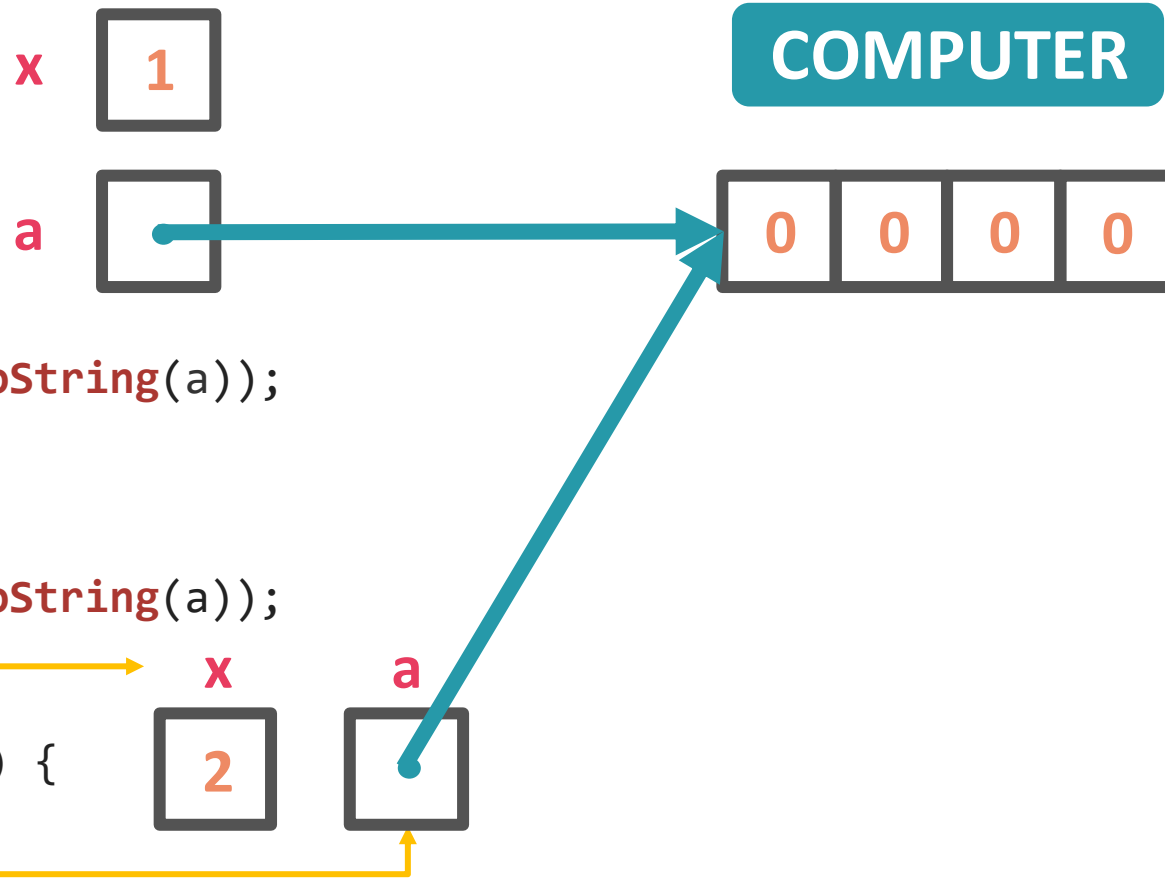



Practice: Think



slido #cse121

```
public static void main(String[] args) {
    int x = 0;
    int[] a = new int[4];
    x++;

    mystery(x, a);
    System.out.println(x + " " + Arrays.toString(a));

    x++;
    mystery(x, a);
    System.out.println(x + " " + Arrays.toString(a));
}
```

```
public static void mystery(int x, int[] a) {
    x++;
    a[x]++;
    System.out.println(x + " " + Arrays.toString(a));
}
```

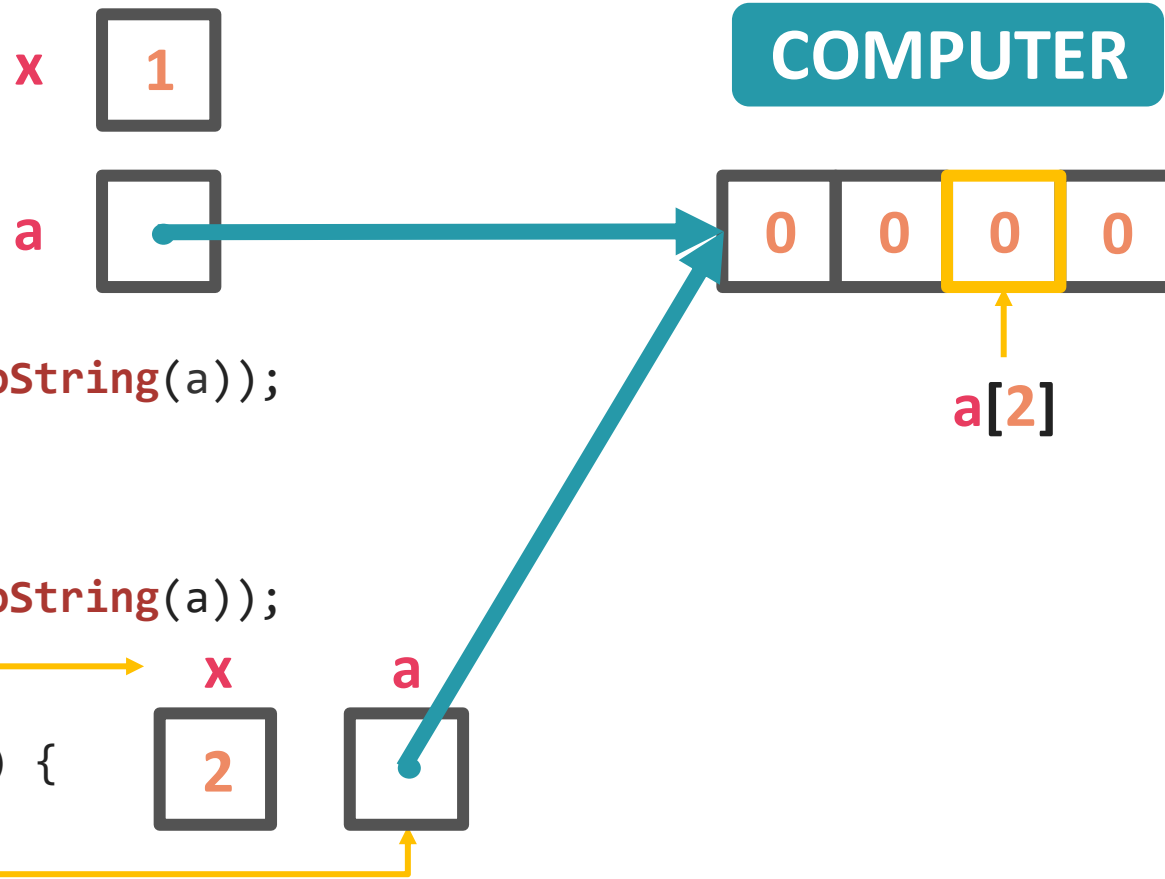



Practice: Think



sli.do #cse121

```
public static void main(String[] args) {
    int x = 0;
    int[] a = new int[4];
    x++;

    mystery(x, a);
    System.out.println(x + " " + Arrays.toString(a));

    x++;
    mystery(x, a);
    System.out.println(x + " " + Arrays.toString(a));
}
```

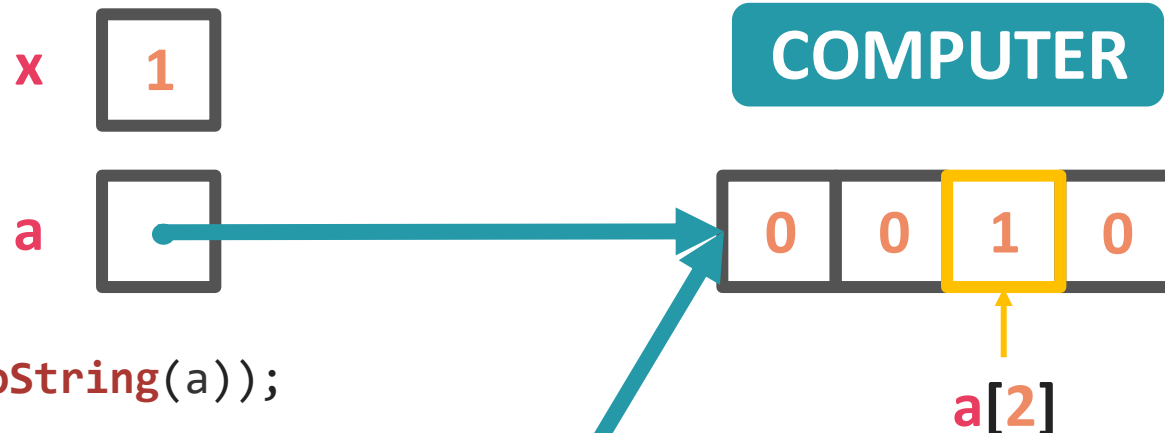

```
public static void mystery(int x, int[] a) {
    x++;
    a[x]++;
    System.out.println(x + " " + Arrays.toString(a));
}
```

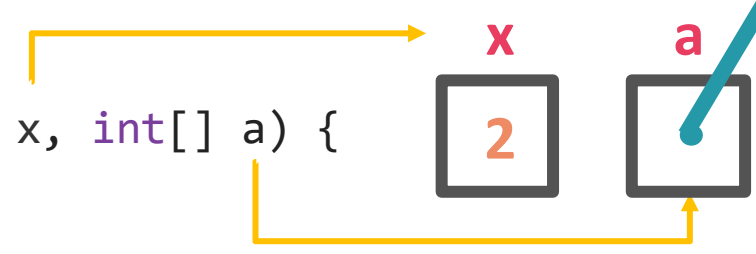



Practice: Think



sli.do #cse121

```
public static void main(String[] args) {
    int x = 0;
    int[] a = new int[4];
    x++;

    mystery(x, a);
    System.out.println(x + " " + Arrays.toString(a));

    x++;
    mystery(x, a);
    System.out.println(x + " " + Arrays.toString(a));
}
```

```
public static void mystery(int x, int[] a) {
    x++;
    a[x]++;
    System.out.println(x + " " + Arrays.toString(a));
}
```

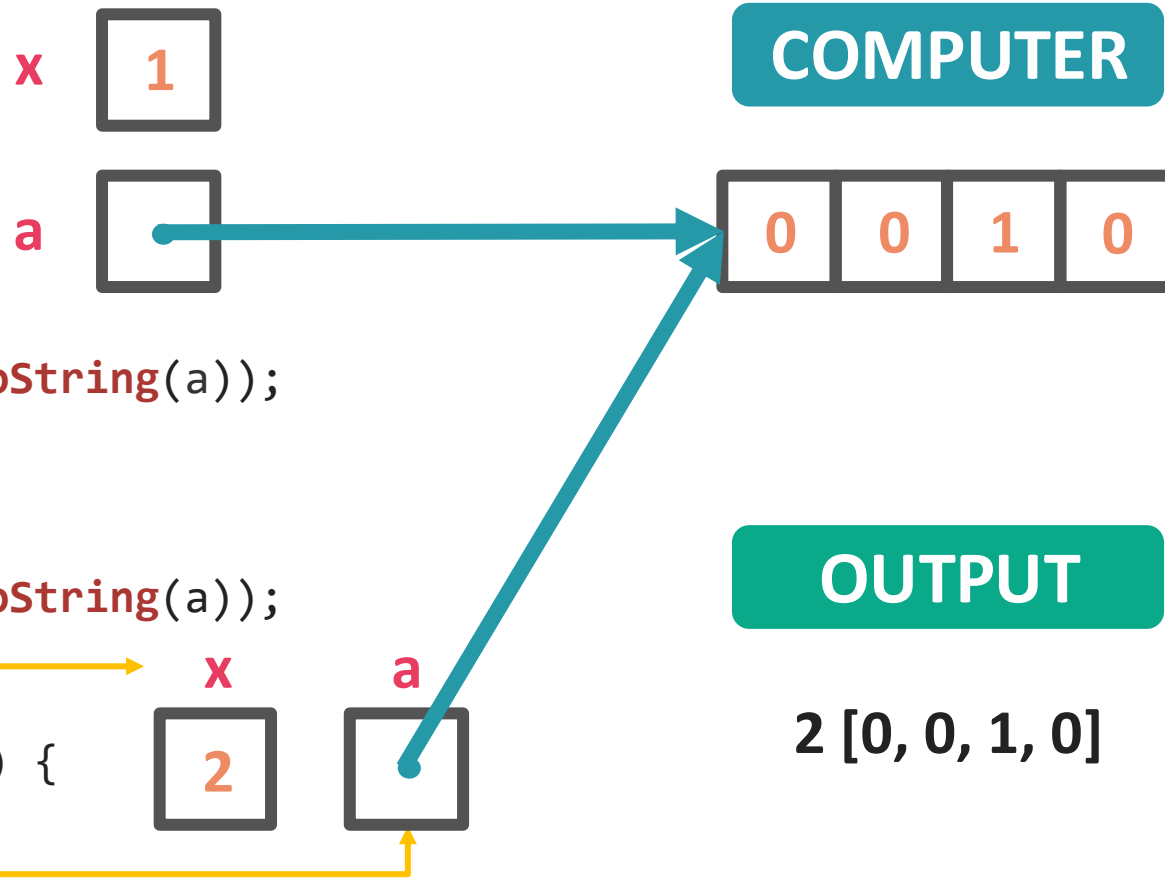



Practice: Think



sli.do #cse121

```
public static void main(String[] args) {
    int x = 0;
    int[] a = new int[4];
    x++;
```

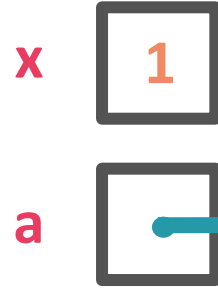

COMPUTER



```
    mystery(x, a);
    System.out.println(x + " " + Arrays.toString(a));

    x++;
    mystery(x, a);
    System.out.println(x + " " + Arrays.toString(a));
}
```

OUTPUT

2 [0, 0, 1, 0]
1 [0, 0, 1, 0]

```
public static void mystery(int x, int[] a) {
    x++;
    a[x]++;
    System.out.println(x + " " + Arrays.toString(a));
}
```

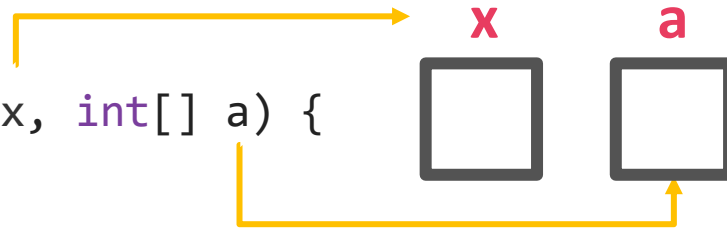



Practice: Think



sli.do #cse121

```
public static void main(String[] args) {
    int x = 0;
    int[] a = new int[4];
    x++;

    mystery(x, a);
    System.out.println(x + " " + Arrays.toString(a));
}

public static void mystery(int x, int[] a) {
    x++;
    a[x]++;
    System.out.println(x + " " + Arrays.toString(a));
}
```



COMPUTER



OUTPUT

2 [0, 0, 1, 0]
1 [0, 0, 1, 0]

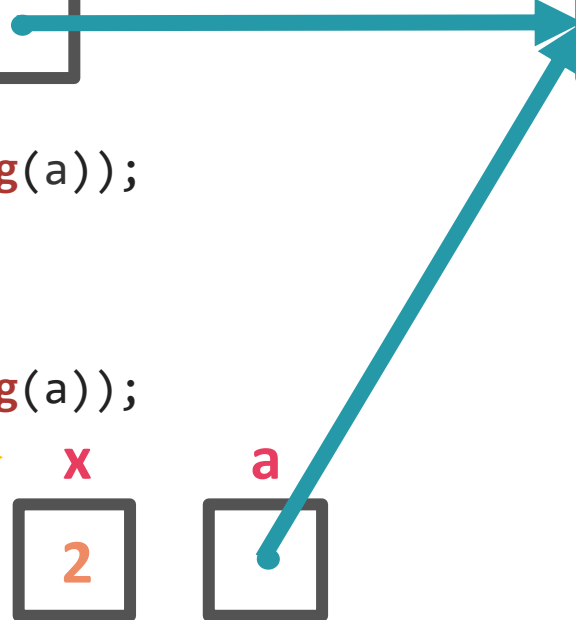



Practice: Think



sli.do #cse121

```
public static void main(String[] args) {
    int x = 0;
    int[] a = new int[4];
    x++;

    mystery(x, a);
    System.out.println(x + " " + Arrays.toString(a));

    x++;
    mystery(x, a);
    System.out.println(x + " " + Arrays.toString(a));
}
```

```
public static void mystery(int x, int[] a) {
    x++;
    a[x]++;
    System.out.println(x + " " + Arrays.toString(a));
}
```

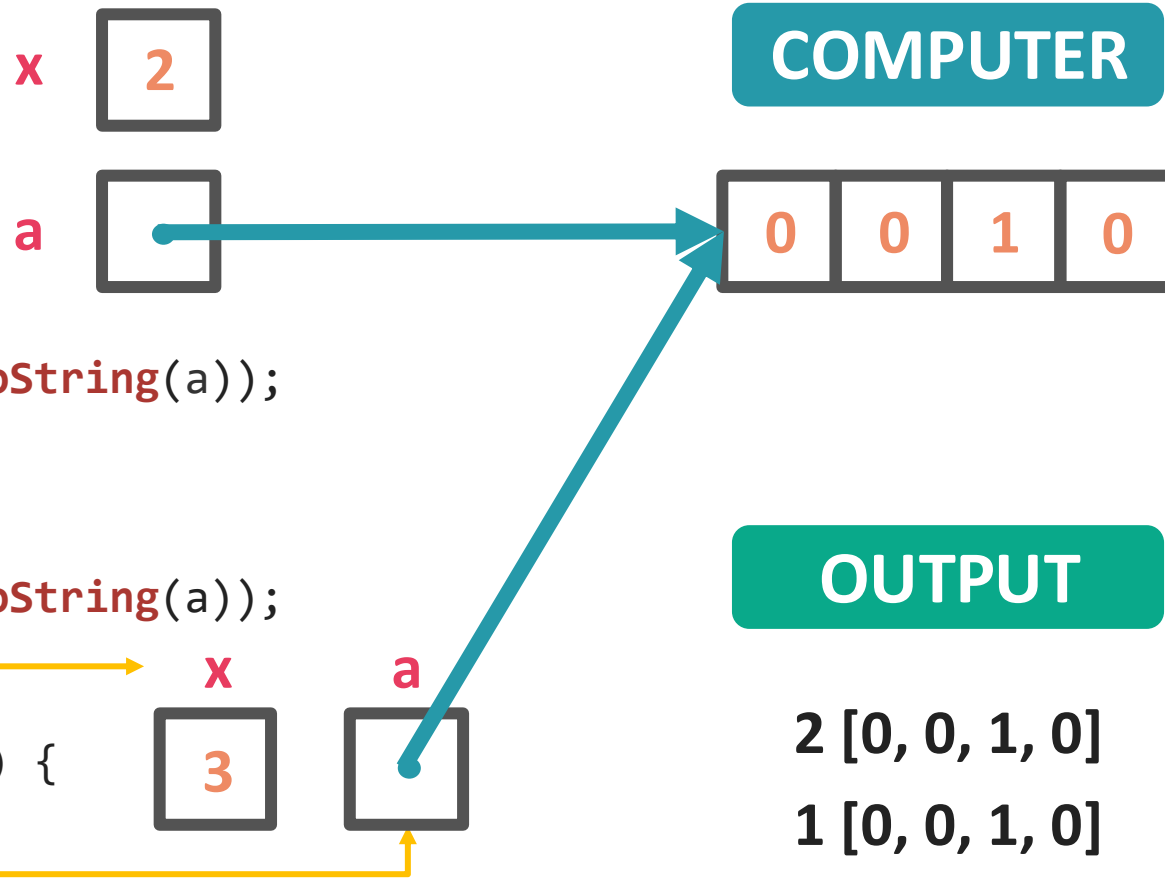

COMPUTER

OUTPUT

2 [0, 0, 1, 0]
1 [0, 0, 1, 0]



Practice: Think



sli.do #cse121

```
public static void main(String[] args) {
    int x = 0;
    int[] a = new int[4];
    x++;

    mystery(x, a);
    System.out.println(x + " " + Arrays.toString(a));

    x++;
    mystery(x, a);
    System.out.println(x + " " + Arrays.toString(a));
}
```

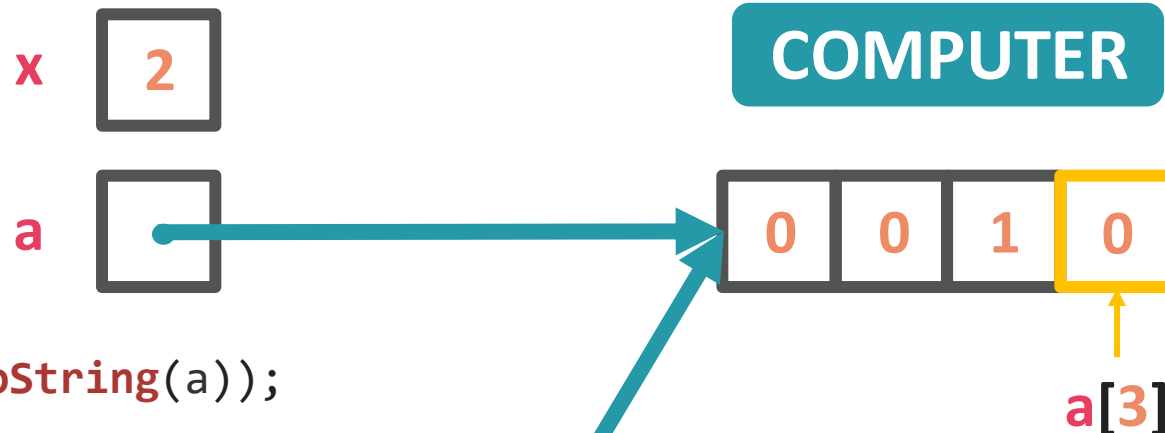

COMPUTER

```
public static void mystery(int x, int[] a) {
    x++;
    a[x]++;
    System.out.println(x + " " + Arrays.toString(a));
}
```

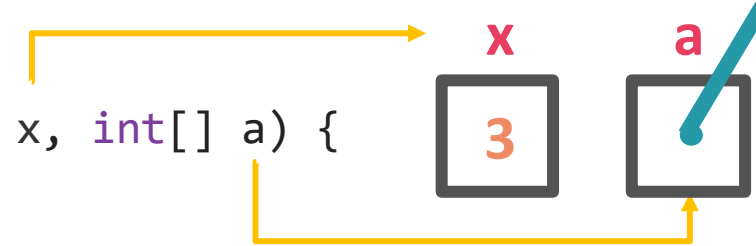

OUTPUT

2 [0, 0, 1, 0]
1 [0, 0, 1, 0]



Practice: Think



sli.do #cse121

```
public static void main(String[] args) {
    int x = 0;
    int[] a = new int[4];
    x++;

    mystery(x, a);
    System.out.println(x + " " + Arrays.toString(a));

    x++;
    mystery(x, a);
    System.out.println(x + " " + Arrays.toString(a));
}
```

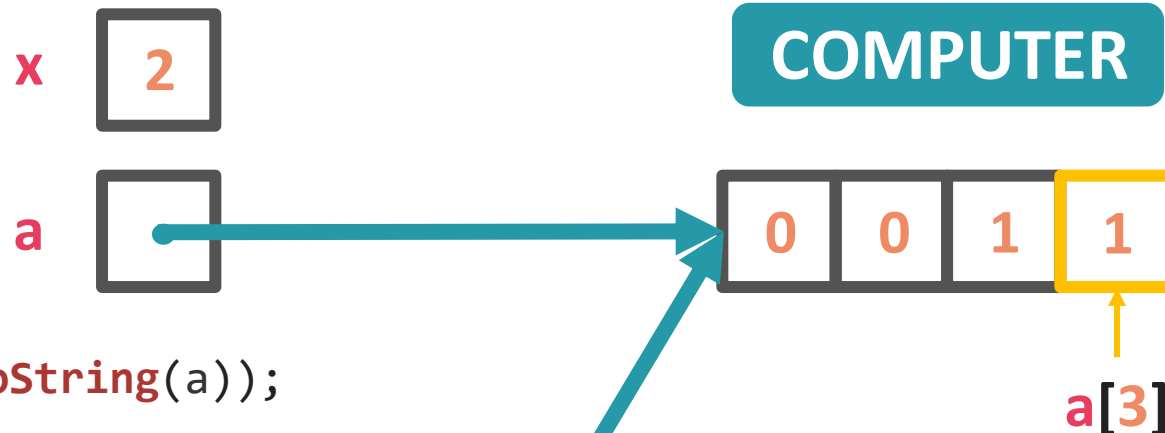

COMPUTER

OUTPUT

2 [0, 0, 1, 0]
1 [0, 0, 1, 0]

```
public static void mystery(int x, int[] a) {
    x++;
    a[x]++;
    System.out.println(x + " " + Arrays.toString(a));
}
```

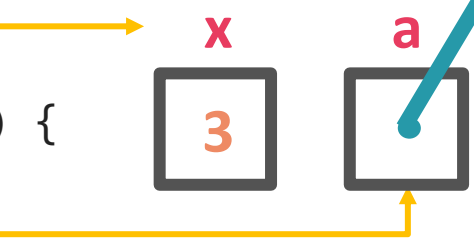



Practice: Think



sli.do #cse121

```
public static void main(String[] args) {
    int x = 0;
    int[] a = new int[4];
    x++;

    mystery(x, a);
    System.out.println(x + " " + Arrays.toString(a));

    x++;
    mystery(x, a);
    System.out.println(x + " " + Arrays.toString(a));
}
```

```
public static void mystery(int x, int[] a) {
    x++;
    a[x]++;
    System.out.println(x + " " + Arrays.toString(a));
}
```

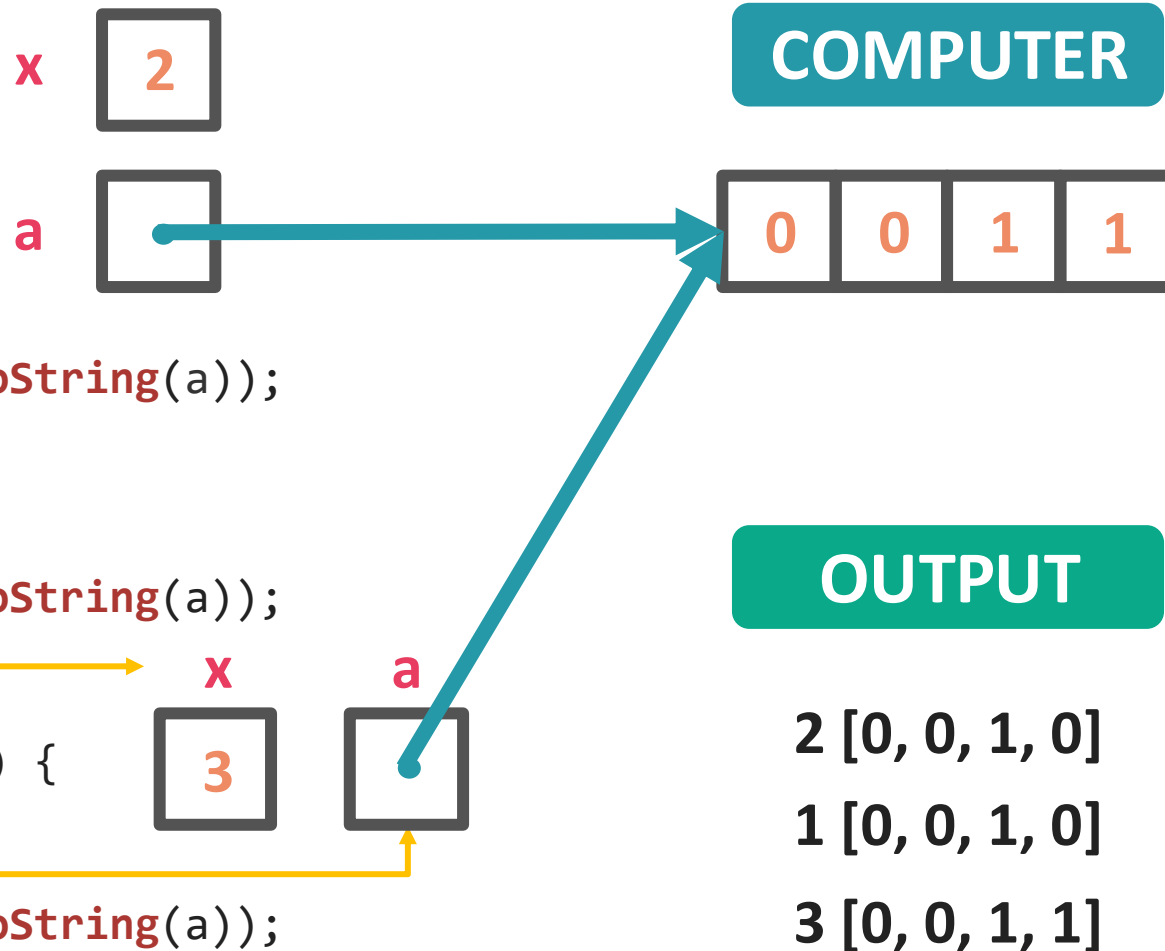



Practice: Think



sli.do #cse121

```
public static void main(String[] args) {
    int x = 0;
    int[] a = new int[4];
    x++;

    mystery(x, a);
    System.out.println(x + " " + Arrays.toString(a));

    x++;
    mystery(x, a);
    System.out.println(x + " " + Arrays.toString(a));
}
```

```
public static void mystery(int x, int[] a) {
    x++;
    a[x]++;
    System.out.println(x + " " + Arrays.toString(a));
}
```

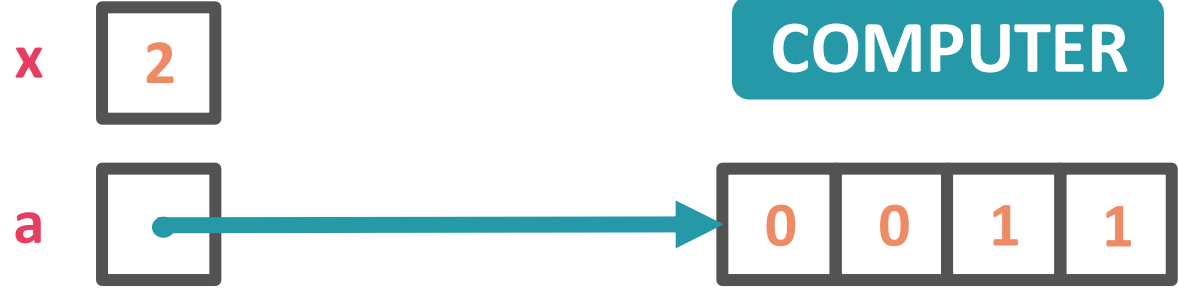

COMPUTER

OUTPUT

- 2 [0, 0, 1, 0]
- 1 [0, 0, 1, 0]
- 3 [0, 0, 1, 1]
- 2 [0, 0, 1, 1]

PCM Review: 2D Arrays

```
int[][] a = new int[4][3];
```

type name array creation code

An array of arrays!

The type of each individual element is another array!

- Your first example of “**nested** data structures”
- There will be more if you take CSE 122!

`int[][]`

`double[][]`

`String[][]`

`boolean[][]`

`char[][]`

Recall: Arrays

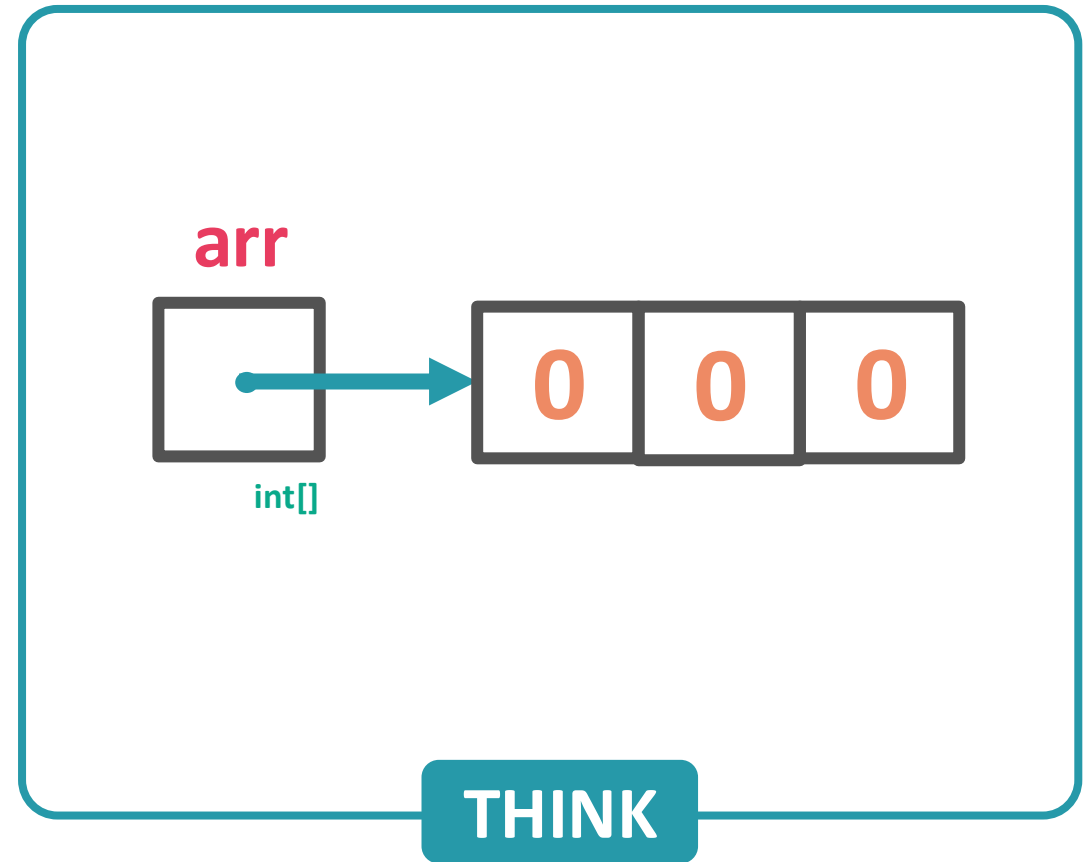
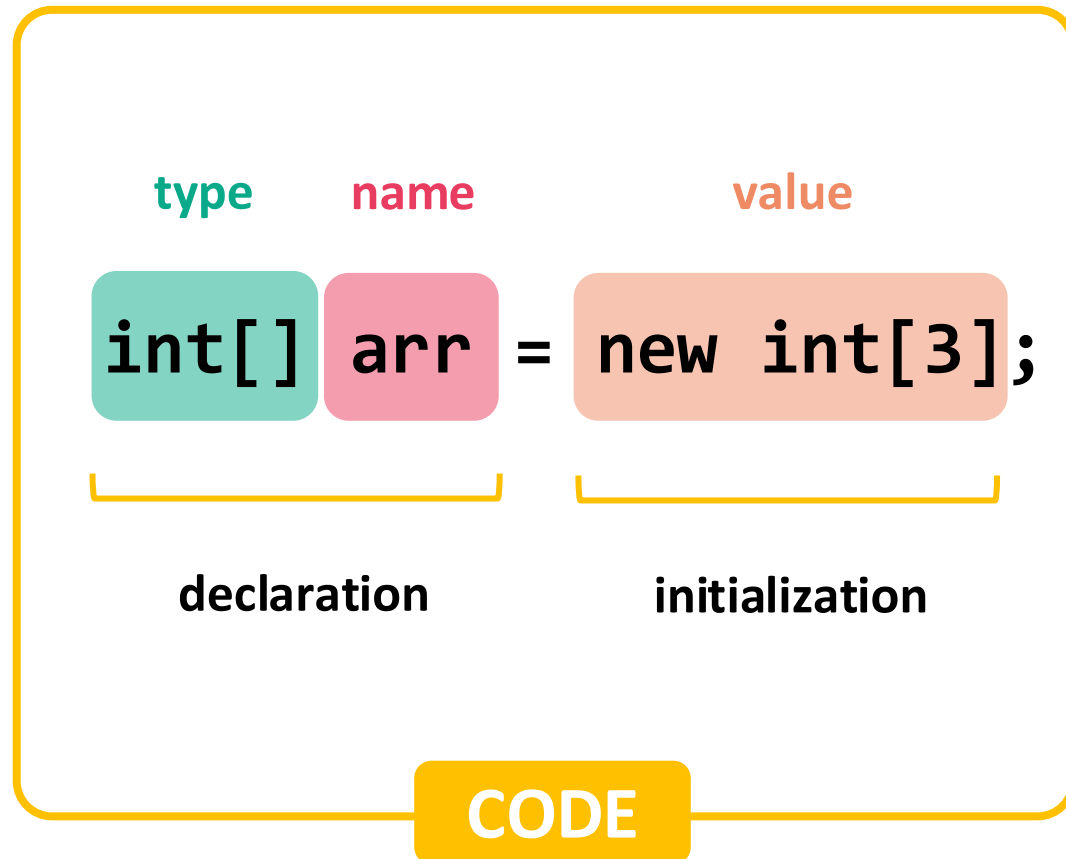

PCM Review: 2D Arrays as Rows and Columns 1

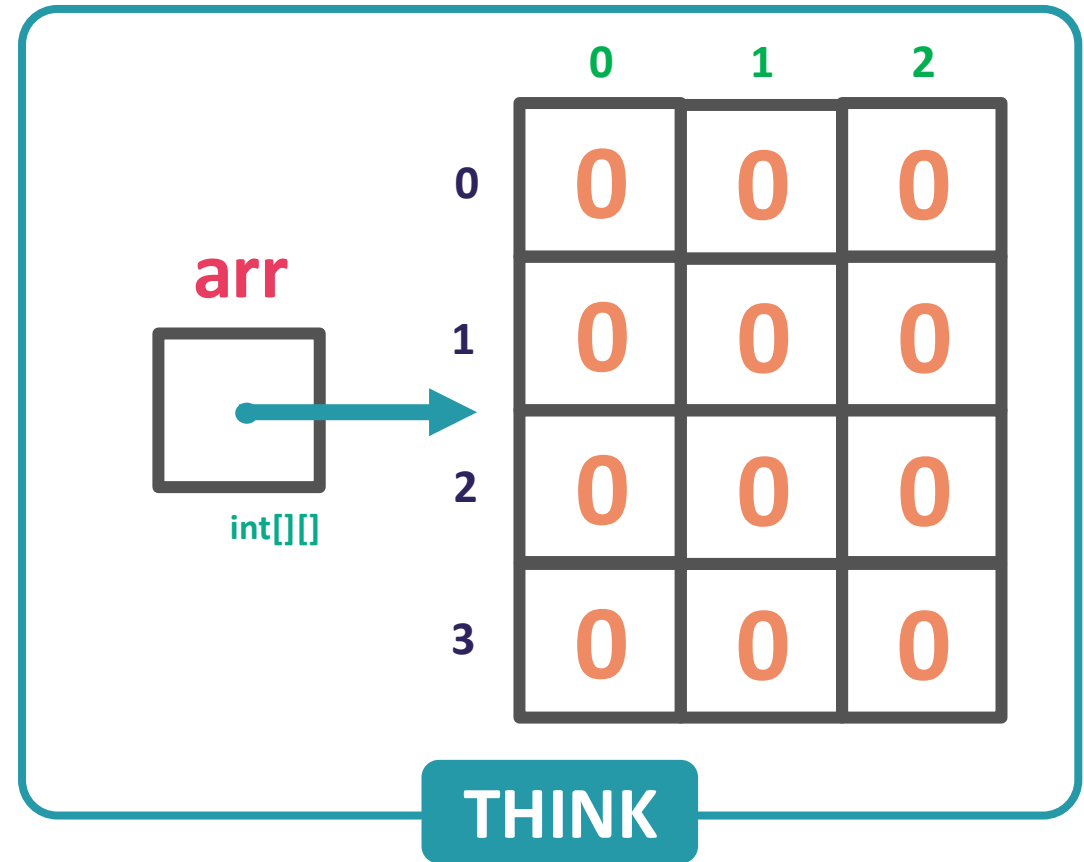
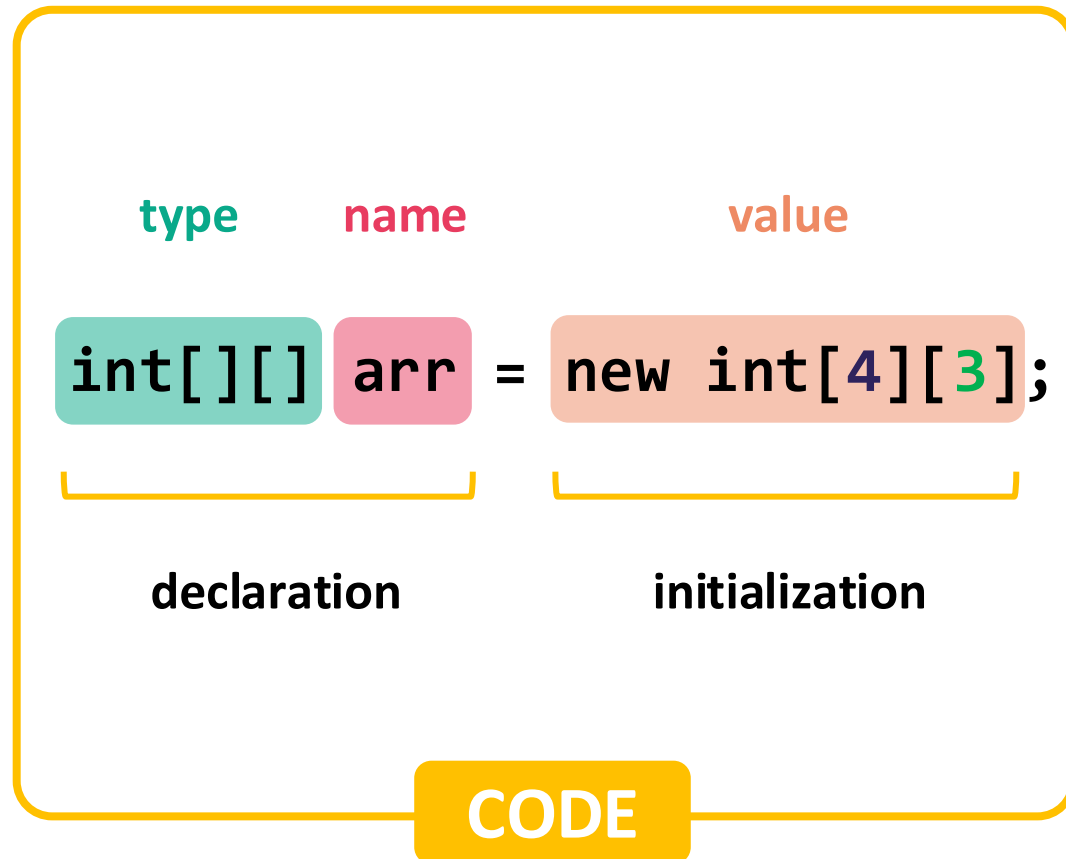

PCM Review: 2D Arrays as Rows and Columns 2

Individual elements are **row-first**, then **column** (“row-major”)

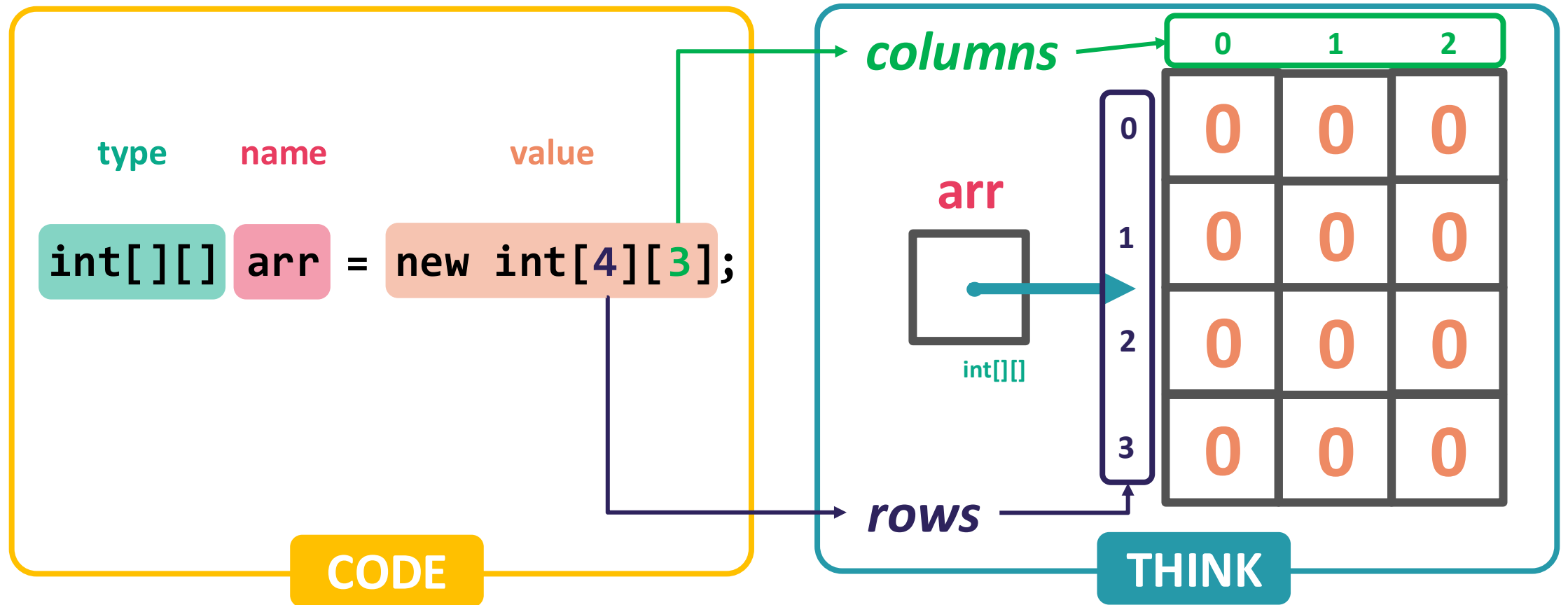

PCM Review: 2D Arrays as Rows and Columns 3

Individual elements are **row-first**, then **column** (“row-major”)

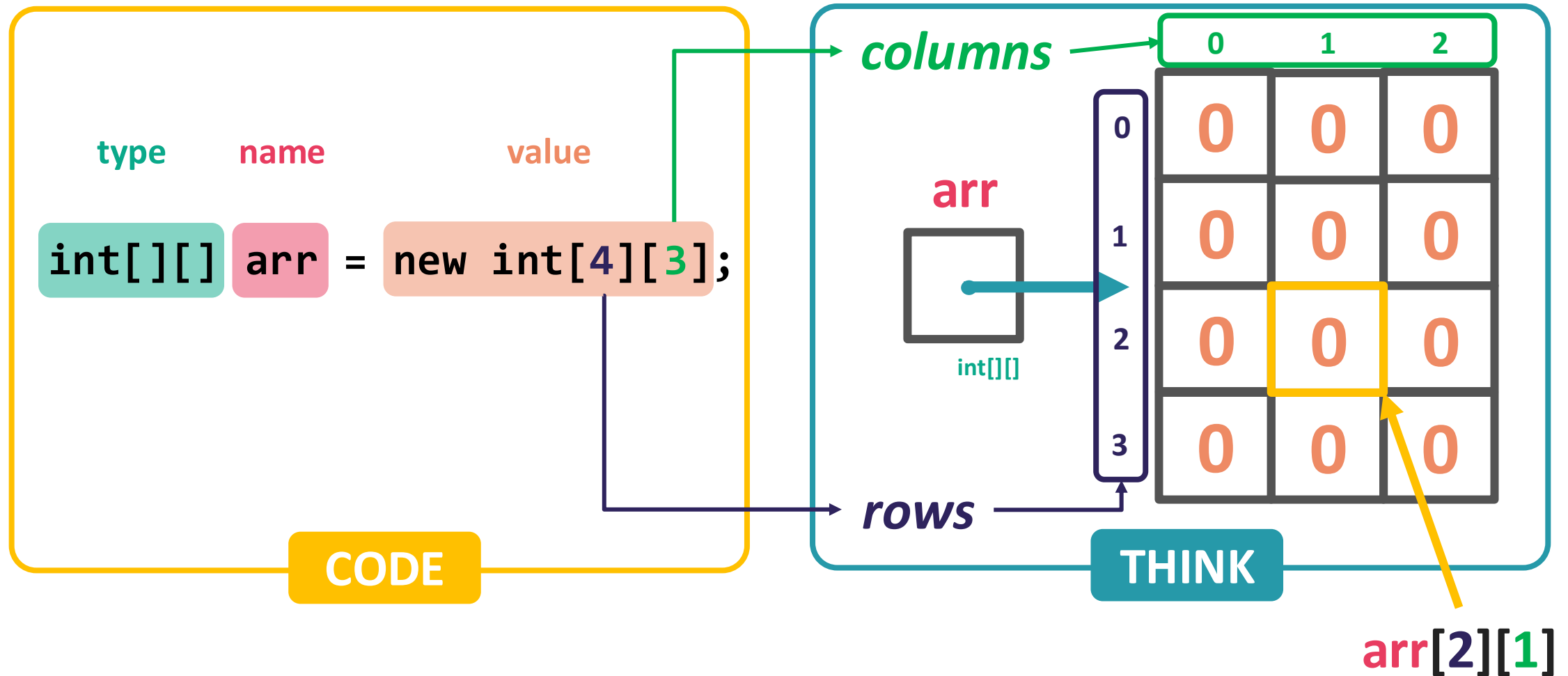

A More Accurate View (Reference Semantics)

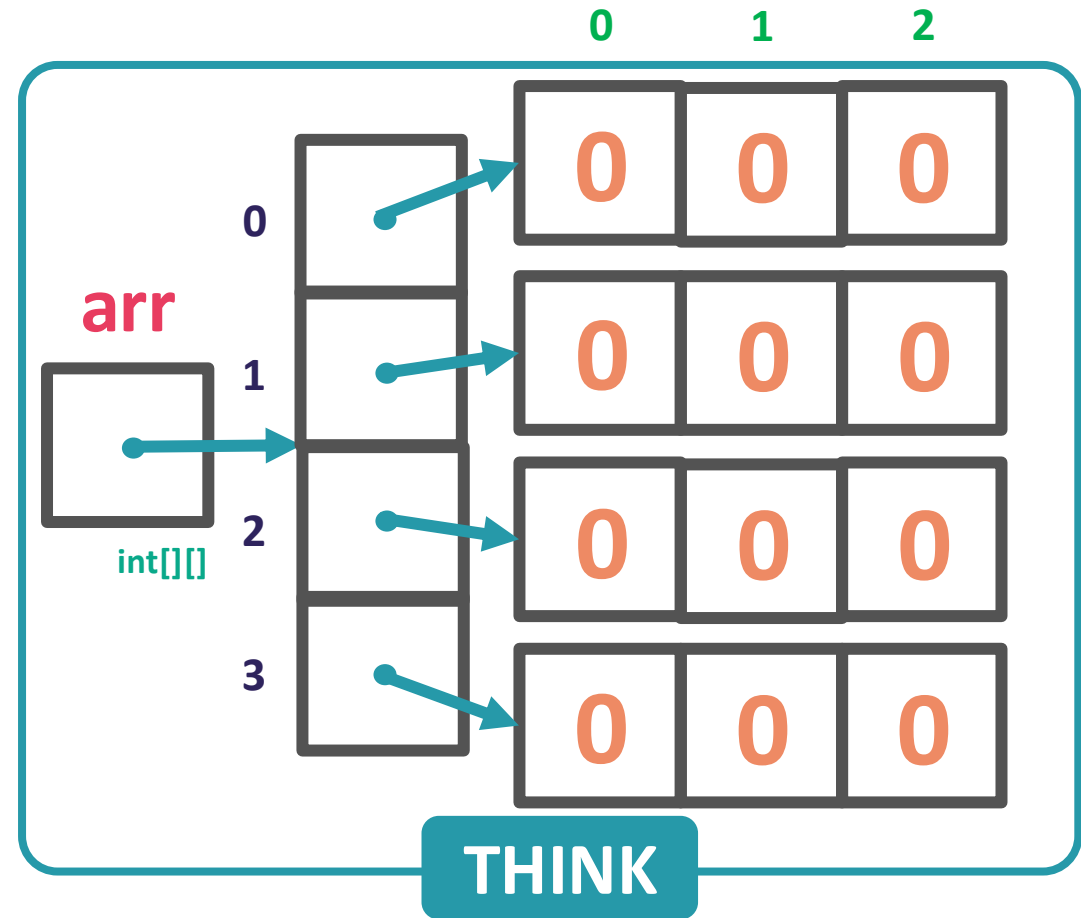
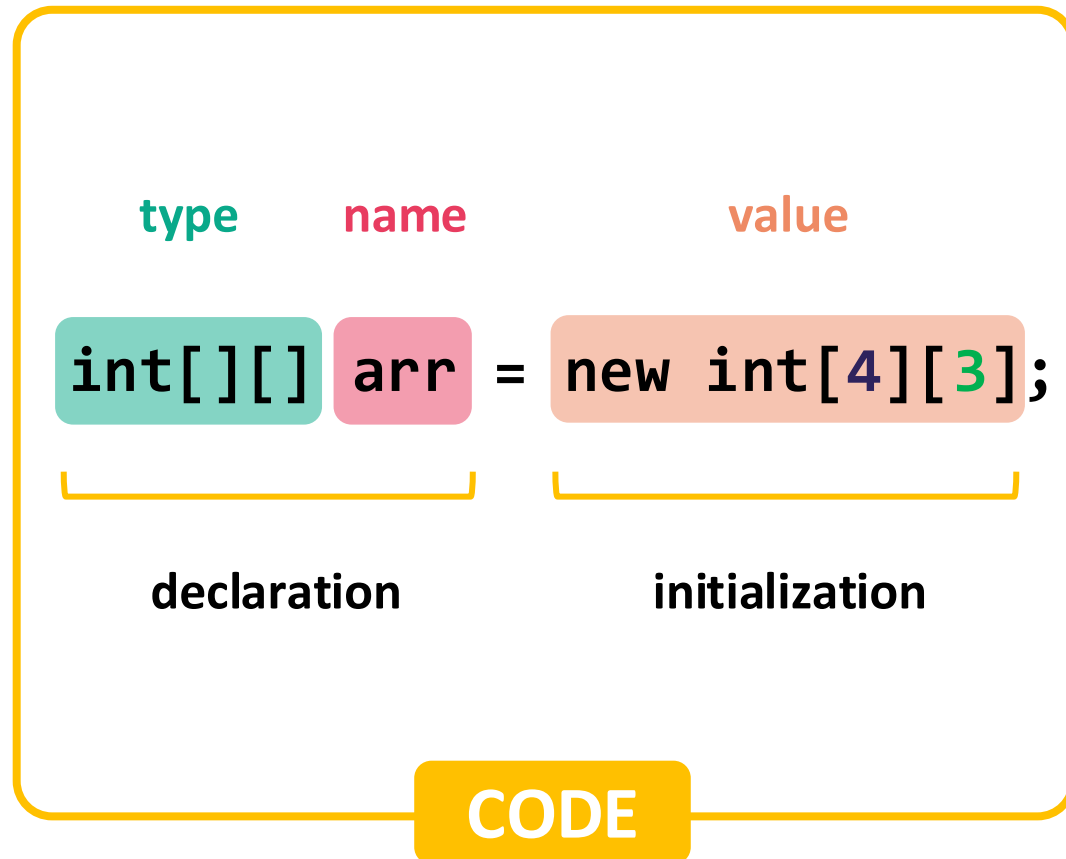

PCM Review: 2D Array Traversals

for each row...

```
for (int i = 0; i < list.length; i++) {  
    for (int j = 0; j < list[i].length; j++) {  
        // do something with list[i][j]  
    }  
}
```

for each element within a row...

Arrays Utility Class (and methods)

Method	Description
<code>Arrays.toString(array)</code>	Returns a String representing the array, such as "[10, 30, -25, 17]"
<code>Arrays.equals(array1, array2)</code>	Returns true if the two arrays contain the same elements in the same order
<code>Arrays.deepToString(array)</code>	Returns a String representing the array; if the array contains other arrays as elements, the String represents their contents, and so on. For example, "[[99, 151], [30, 5]]"
<code>Arrays.deepEquals(arr1, arr2)</code>	Returns true if the two arrays contain the same elements in the same order; if the array(s) contain other arrays as elements, their contents are tested for equality, and so on.

Applications of 2D Arrays

- **Matrices**
 - Useful in *so many* applications in math, engineering, and statistics
 - Fundamental to machine learning & AI
 - P3 is one real-life application of this! (bioinformatics)
- Board games
 - e.g. chess, checkers, tic-tac-toe, sudoku
- Tabular or grid-like data
 - e.g. scorekeeping, gradebook, census data
- Image processing

matrixAdd

23	96	18	4	64
45	40	18	44	34
92	13	77	71	12



70	73	66	79	39
91	75	73	99	47
27	64	21	34	1

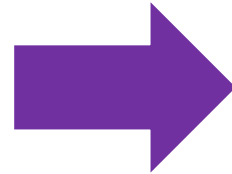

matrixAdd: first row

23	96	18	4	64
45	40	18	44	34
92	13	77	71	12



70	73	66	79	39
91	75	73	99	47
27	64	21	34	1

i: 0

j: 0

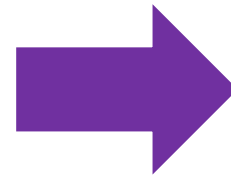

matrixAdd: 0,0

<u>23</u>	96	18	4	64
45	40	18	44	34
92	13	77	71	12



<u>70</u>	73	66	79	39
91	75	73	99	47
27	64	21	34	1

i: 0
j: 0

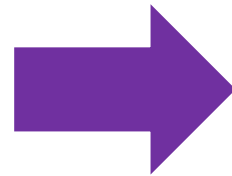

<u>93</u>				

matrixAdd: 0,1

23	<u>96</u>	18	4	64
45	40	18	44	34
92	13	77	71	12



70	<u>73</u>	66	79	39
91	75	73	99	47
27	64	21	34	1

i: 0
j: 1

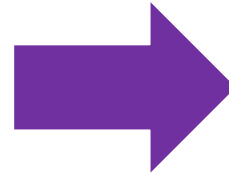

93	<u>169</u>			

matrixAdd: 0, 2

23	96	<u>18</u>	4	64
45	40	18	44	34
92	13	77	71	12



70	73	<u>66</u>	79	39
91	75	73	99	47
27	64	21	34	1

i: 0
j: 2

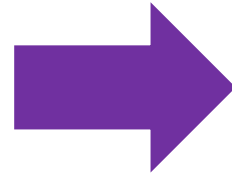

93	169	<u>84</u>		

matrixAdd: 0,3

23	96	18	<u>4</u>	64
45	40	18	44	34
92	13	77	71	12



70	73	66	<u>79</u>	39
91	75	73	99	47
27	64	21	34	1

i: 0
j: 3

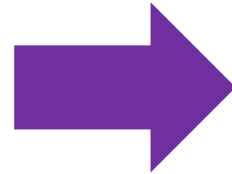

93	169	84	<u>83</u>	

matrixAdd: 0,4

23	96	18	4	<u>64</u>
45	40	18	44	34
92	13	77	71	12



70	73	66	79	<u>39</u>
91	75	73	99	47
27	64	21	34	1

i: 0
j: 4

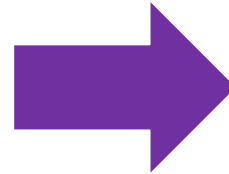

93	169	84	83	<u>103</u>

matrixAdd: 1,0

23	96	18	4	64
<u>45</u>	40	18	44	34
92	13	77	71	12



70	73	66	79	39
<u>91</u>	75	73	99	47
27	64	21	34	1

i: 1
j: 0

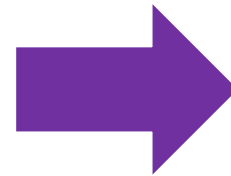

93	169	84	83	103
<u>136</u>				

matrixAdd: 1,1

23	96	18	4	64
45	<u>40</u>	18	44	34
92	13	77	71	12



70	73	66	79	39
91	<u>75</u>	73	99	47
27	64	21	34	1

i: 1
j: 1

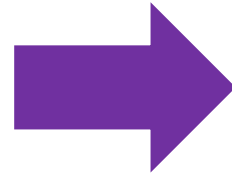

93	169	84	83	103
136	<u>115</u>			

matrixAdd: 1, 2

23	96	18	4	64
45	40	<u>18</u>	44	34
92	13	77	71	12



70	73	66	79	39
91	75	<u>73</u>	99	47
27	64	21	34	1

i: 1
j: 2

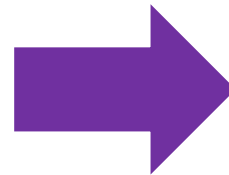

93	169	84	83	103
136	115	<u>91</u>		

matrixAdd: 1, 3

23	96	18	4	64
45	40	18	<u>44</u>	34
92	13	77	71	12



70	73	66	79	39
91	75	73	<u>99</u>	47
27	64	21	34	1

i: 1
j: 3

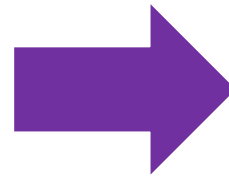

93	169	84	83	103
136	115	91	<u>143</u>	

matrixAdd: 1,4

23	96	18	4	64
45	40	18	44	<u>34</u>
92	13	77	71	12



70	73	66	79	39
91	75	73	99	<u>47</u>
27	64	21	34	1

i: 1
j: 4

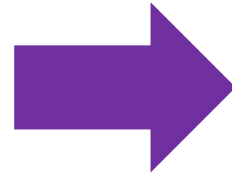

93	169	84	83	103
136	115	91	143	<u>81</u>

matrixAdd: 2,0

23	96	18	4	64
45	40	18	44	34
<u>92</u>	13	77	71	12



70	73	66	79	39
91	75	73	99	47
<u>27</u>	64	21	34	1

i: 2
j: 0

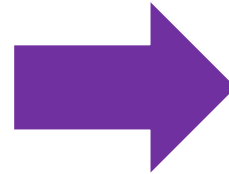

93	169	84	83	103
136	115	91	143	81
<u>119</u>				

matrixAdd: 2,1

23	96	18	4	64
45	40	18	44	34
92	<u>13</u>	77	71	12



70	73	66	79	39
91	75	73	99	47
27	<u>64</u>	21	34	1

i: 2
j: 1

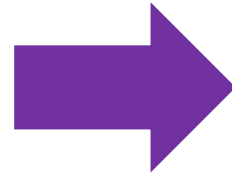

93	169	84	83	103
136	115	91	143	81
119	<u>77</u>			

matrixAdd: 2,2

23	96	18	4	64
45	40	18	44	34
92	13	<u>77</u>	71	12



70	73	66	79	39
91	75	73	99	47
27	64	<u>21</u>	34	1

i: 2
j: 2

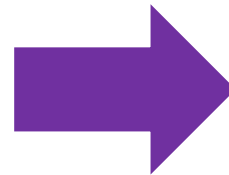

93	169	84	83	103
136	115	91	143	81
119	77	<u>98</u>		

matrixAdd: 2,3

23	96	18	4	64
45	40	18	44	34
92	13	77	<u>71</u>	12



70	73	66	79	39
91	75	73	99	47
27	64	21	<u>34</u>	1

i: 2
j: 3

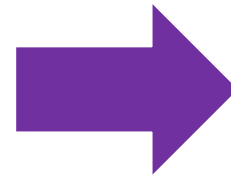

93	169	84	83	103
136	115	91	143	81
119	77	98	<u>105</u>	

matrixAdd: 2,4

23	96	18	4	64
45	40	18	44	34
92	13	77	71	<u>12</u>



70	73	66	79	39
91	75	73	99	47
27	64	21	34	<u>1</u>

i: 2
j: 4

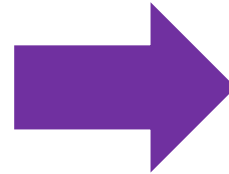

93	169	84	83	103
136	115	91	143	81
119	77	98	105	<u>13</u>

matrixAdd: finished!

23	96	18	4	64
45	40	18	44	34
92	13	77	71	12



70	73	66	79	39
91	75	73	99	47
27	64	21	34	1

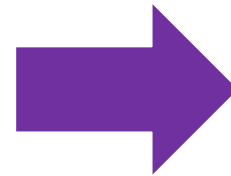

93	169	84	83	103
136	115	91	143	81
119	77	98	105	13

readData: processing input

```
How many days' data would you like to input? 3
```

```
Next day's data:
```

```
  Temperature in Seattle? 44
```

```
  Temperature in Tacoma? 40
```

```
  Temperature in Bothell? 43
```

```
Next day's data:
```

```
  Temperature in Seattle? 42
```

```
  Temperature in Tacoma? 40
```

```
  Temperature in Bothell? 44
```

```
Next day's data:
```

```
  Temperature in Seattle? 42
```

```
  Temperature in Tacoma? 41
```

```
  Temperature in Bothell? 43
```

```
...
```

readData: days



How many days' data would you like to input? 3

Next day's data:

Temperature in Seattle?

Temperature in Tacoma?

Temperature in Bothell?

Next day's data:

Temperature in Seattle?

Temperature in Tacoma?

Temperature in Bothell?

Next day's data:

Temperature in Seattle?

Temperature in Tacoma?

Temperature in Bothell?

...

	Seattle	Tacoma	Bothell
1			
2			
3			

readData: 1, Seattle

How many days' data would you like to input? 3

Next day's data:

Temperature in Seattle? 44

Temperature in Tacoma?

Temperature in Bothell?

Next day's data:

Temperature in Seattle?

Temperature in Tacoma?

Temperature in Bothell?

Next day's data:

Temperature in Seattle?

Temperature in Tacoma?

Temperature in Bothell?

...

	Seattle	Tacoma	Bothell
1	44		
2			
3			

readData: 1, Tacoma

How many days' data would you like to input? 3

Next day's data:

Temperature in Seattle? 44

Temperature in Tacoma? 40

Temperature in Bothell?

Next day's data:

Temperature in Seattle?

Temperature in Tacoma?

Temperature in Bothell?

Next day's data:

Temperature in Seattle?

Temperature in Tacoma?

Temperature in Bothell?

...

	Seattle	Tacoma	Bothell
1	44	40	
2			
3			

readData: 1, Bothell

How many days' data would you like to input? 3

Next day's data:

Temperature in Seattle? 44

Temperature in Tacoma? 40

Temperature in Bothell? 43

Next day's data:

Temperature in Seattle?

Temperature in Tacoma?

Temperature in Bothell?

Next day's data:

Temperature in Seattle?

Temperature in Tacoma?

Temperature in Bothell?

...

	Seattle	Tacoma	Bothell
1	44	40	43
2			
3			

readData: 2, Seattle

How many days' data would you like to input? 3

Next day's data:

Temperature in Seattle? 44

Temperature in Tacoma? 40

Temperature in Bothell? 43

Next day's data:

Temperature in Seattle? 42

Temperature in Tacoma?

Temperature in Bothell?

Next day's data:

Temperature in Seattle?

Temperature in Tacoma?

Temperature in Bothell?

...



	Seattle	Tacoma	Bothell
1	44	40	43
2	42		
3			

readData: 2, Tacoma

How many days' data would you like to input? 3

Next day's data:

Temperature in Seattle? 44

Temperature in Tacoma? 40

Temperature in Bothell? 43

Next day's data:

Temperature in Seattle? 42

Temperature in Tacoma? 40

Temperature in Bothell?

Next day's data:

Temperature in Seattle?

Temperature in Tacoma?

Temperature in Bothell?

...



	Seattle	Tacoma	Bothell
1	44	40	43
2	42	40	
3			

readData: 2, Bothell

How many days' data would you like to input? 3

Next day's data:

Temperature in Seattle? 44

Temperature in Tacoma? 40

Temperature in Bothell? 43

Next day's data:

Temperature in Seattle? 42

Temperature in Tacoma? 40

Temperature in Bothell? 44

Next day's data:

Temperature in Seattle?

Temperature in Tacoma?

Temperature in Bothell?

...

	Seattle	Tacoma	Bothell
1	44	40	43
2	42	40	44
3			

readData: 2, Seattle

How many days' data would you like to input? 3

Next day's data:

Temperature in Seattle? 44

Temperature in Tacoma? 40

Temperature in Bothell? 43

Next day's data:

Temperature in Seattle? 42

Temperature in Tacoma? 40

Temperature in Bothell? 44

Next day's data:

Temperature in Seattle? 42

Temperature in Tacoma?

Temperature in Bothell?

...

	Seattle	Tacoma	Bothell
1	44	40	43
2	42	40	44
3	42		



readData: 2, Tacoma

How many days' data would you like to input? 3

Next day's data:

Temperature in Seattle? 44

Temperature in Tacoma? 40

Temperature in Bothell? 43

Next day's data:

Temperature in Seattle? 42

Temperature in Tacoma? 40

Temperature in Bothell? 44

Next day's data:

Temperature in Seattle? 42

Temperature in Tacoma? 41

Temperature in Bothell?

...

	Seattle	Tacoma	Bothell
1	44	40	43
2	42	40	44
3	42	41	



readData: 2, Bothell

How many days' data would you like to input? 3

Next day's data:

Temperature in Seattle? 44

Temperature in Tacoma? 40

Temperature in Bothell? 43

Next day's data:

Temperature in Seattle? 42

Temperature in Tacoma? 40

Temperature in Bothell? 44

Next day's data:

Temperature in Seattle? 42

Temperature in Tacoma? 41

Temperature in Bothell? 43

...

	Seattle	Tacoma	Bothell
1	44	40	43
2	42	40	44
3	42	41	43



computeAverages

	Seattle	Tacoma	Bothell
1	44	40	43
2	42	40	44
3	42	41	43

How many days' data would you like to input? 3

...

The average values for each location were
[42.666666666666664, 40.333333333333336,
43.333333333333336]



42.667	40.333	43.333
--------	--------	--------

Average of Seattle
temperatures
 $(44 + 42 + 42) / 3$