

## Announcements:

- Today: HW2 due / HW3 release
- Remember to tag your submissions in Gradescope
- Project proposals –TAs will reach out with feedback

# Link Analysis for Recommender Systems and Web Spam

---

CS547 Machine Learning for Big Data

Tim Althoff



PAUL G. ALLEN SCHOOL  
OF COMPUTER SCIENCE & ENGINEERING

# Example: PageRank Scores

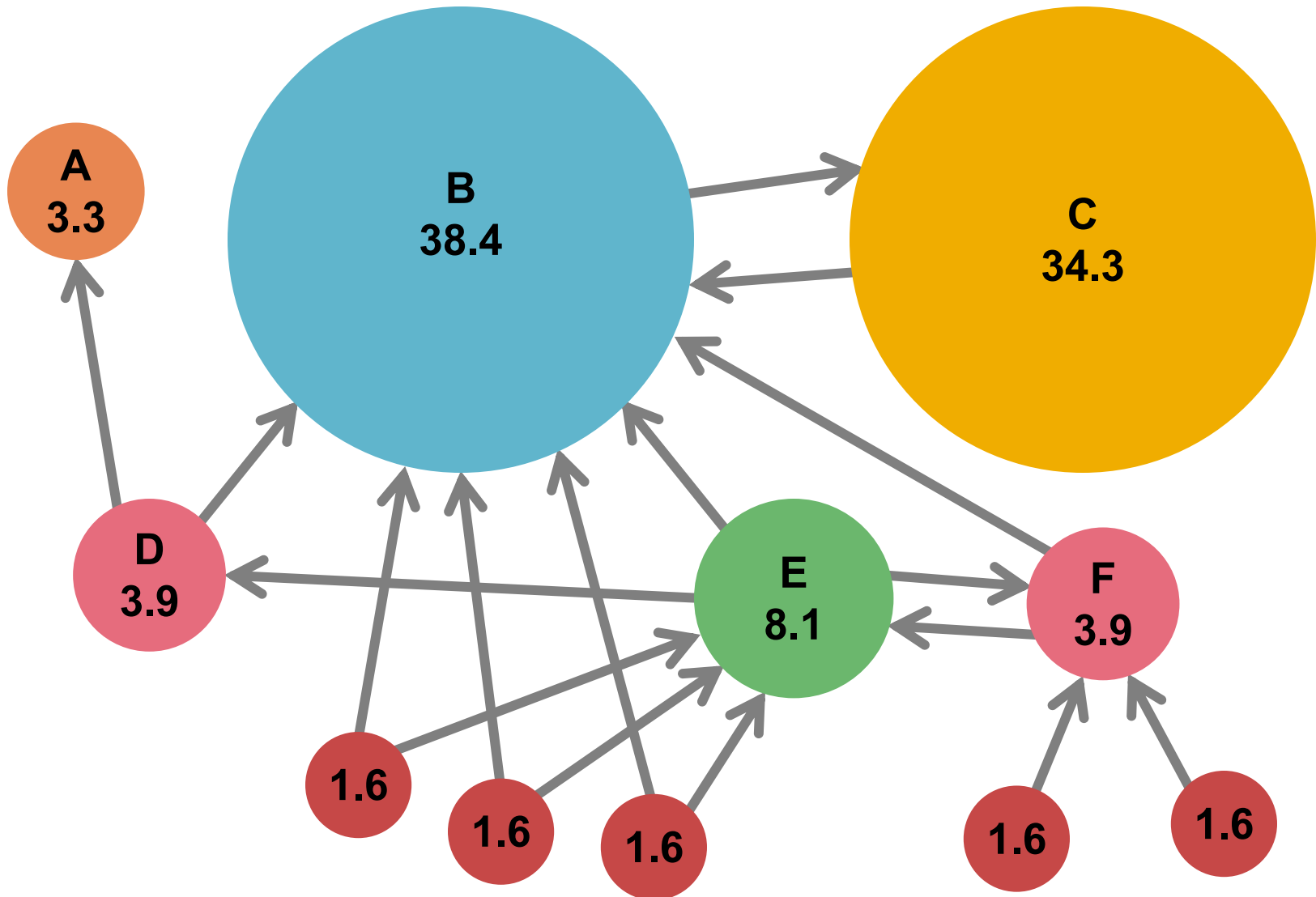

# Random Teleports ( $\beta = 0.8$ )

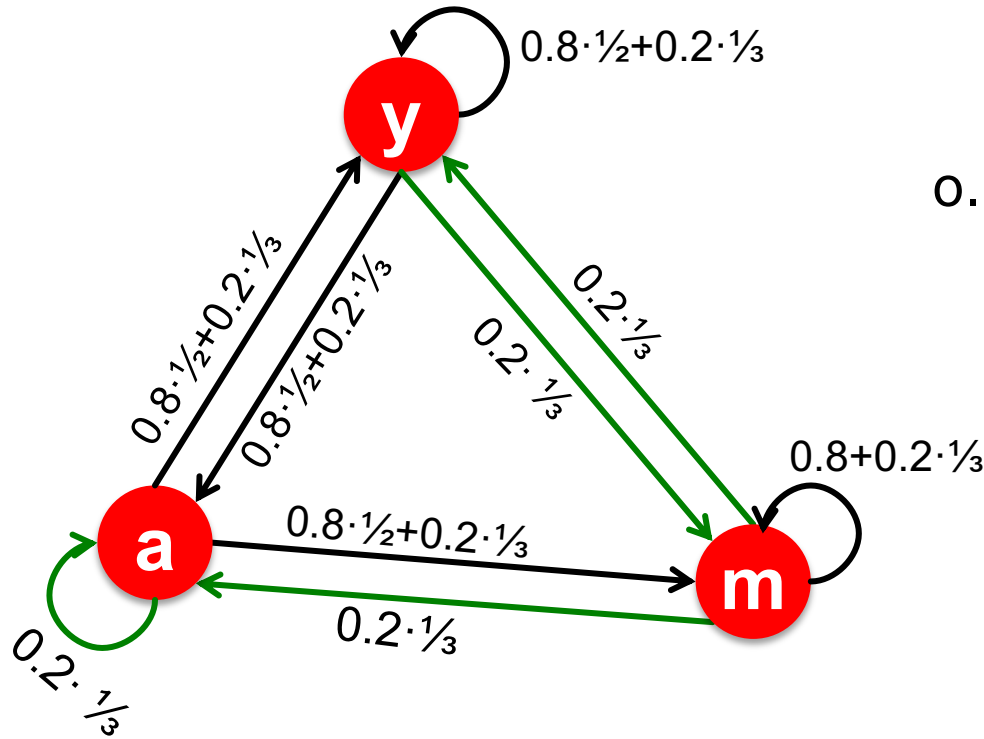

$$0.8 \begin{bmatrix} 1/2 & 1/2 & 0 \\ 1/2 & 0 & 0 \\ 0 & 1/2 & 1 \end{bmatrix} + 0.2 \begin{bmatrix} 1/3 & 1/3 & 1/3 \\ 1/3 & 1/3 & 1/3 \\ 1/3 & 1/3 & 1/3 \end{bmatrix}$$

$$\begin{matrix} y \\ a \\ m \end{matrix} \begin{bmatrix} 7/15 & 7/15 & 1/15 \\ 7/15 & 1/15 & 1/15 \\ 1/15 & 7/15 & 13/15 \end{bmatrix}$$

**A**

$$\begin{matrix} y \\ a \\ m \end{matrix} = \begin{matrix} 1/3 & 0.33 & 0.24 & 0.26 & & 7/33 \\ 1/3 & 0.20 & 0.20 & 0.18 & \dots & 5/33 \\ 1/3 & 0.46 & 0.52 & 0.56 & & 21/33 \end{matrix}$$

$$\mathbf{r} = \mathbf{A} \mathbf{r}$$

# PageRank: The Complete Algorithm

- **Input: Graph  $G$  and parameter  $\beta$** 
  - Directed graph  $G$  (can have **spider traps** and **dead ends**)
  - Parameter  $\beta$
- **Output: PageRank vector  $r$**

- **Set:**  $r_j^{(0)} = \frac{1}{N}, t = 1$
- **Do:**  $\forall j: r'_j = \sum_{i \rightarrow j} \beta \frac{r_i^{(t-1)}}{d_i}$   
 $r'_j = 0$  if in-degree of  $j$  is 0
  - **Now re-insert the leaked PageRank:**  
 $\forall j: r_j^{(t)} = r'_j + \frac{1-S}{N}$  where:  $S = \sum_j r'_j$
  - $t = t + 1$
- **while**  $\sum_j \left| r_j^{(t)} - r_j^{(t-1)} \right| < \epsilon$

If the graph has no dead-ends then the amount of leaked PageRank is  $1-\beta$ . But since we have dead-ends the amount of leaked PageRank may be larger. We have to explicitly account for it by computing  $S$ .

# Some Problems with PageRank

- **Measures generic popularity of a page**
  - Will ignore/miss topic-specific authorities
  - **Solution:** Topic-Specific PageRank (**next**)
- **Uses a single measure of importance**
  - Other models of importance
  - **Solution:** Hubs-and-Authorities
- **Susceptible to Link spam**
  - Artificial link topographies created in order to boost page rank
  - **Solution:** TrustRank (**later today**)

# Topic-Specific PageRank

---

# Topic-Specific PageRank

- **Instead of generic popularity, can we measure popularity within a topic?**
- **Goal:** Evaluate Web pages not just according to their popularity, but also by how close they are to a particular topic, e.g. “sports” or “history”
- **Allows search queries to be answered based on interests of the user**
  - **Example:** Query “Trojan” wants different pages depending on whether you are interested in sports, history, or computer security

# Topic-Specific PageRank

- Random walker has a small probability of teleporting at any step
- **Teleport can go to:**
  - **Standard PageRank:** Any page with equal probability
    - To avoid dead-end and spider-trap problems
  - **Topic Specific PageRank:** A topic-specific set of “relevant” pages (**teleport set**)
- **Idea: Bias the random walk**
  - When the walker teleports, she picks a page from a set  $\mathcal{S}$
  - $\mathcal{S}$  contains only pages that are relevant to the topic
    - E.g., Open Directory (DMOZ) pages for a given topic/query
  - For each teleport set  $\mathcal{S}$ , we get a different vector  $\mathbf{r}_{\mathcal{S}}$



# Matrix Formulation

- To make this work all we need is to update the teleportation part of the PageRank formulation:

$$A_{ij} = \begin{cases} \beta M_{ij} + (1 - \beta)/|S| & \text{if } i \in S \\ \beta M_{ij} + 0 & \text{otherwise} \end{cases}$$

- $A$  is a column-stochastic matrix!
- We weighted all pages in the teleport set  $S$  equally
  - Could also assign different weights to pages!
- Compute as for regular PageRank:
  - Multiply by  $M$ , then add a vector
  - Maintains sparseness

# Example: Topic-Specific PageRank

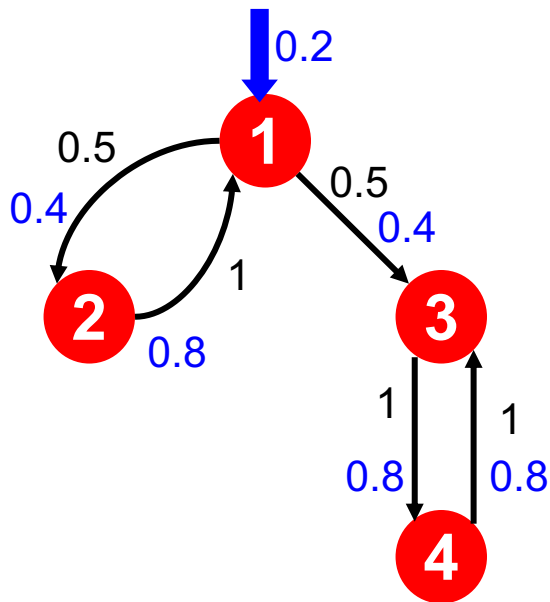

Suppose  $S = \{1\}$ ,  $\beta = 0.8$

Node	Iteration 0	1	2	...	stable
1	0.25	0.4	0.28		0.294
2	0.25	0.1	0.16		0.118
3	0.25	0.3	0.32		0.327
4	0.25	0.2	0.24		0.261

S	$\beta$	$r_1$	$r_2$	$r_3$	$r_4$
{1}	<b>0.9</b>	0.17	0.07	0.40	0.36
{1}	<b>0.8</b>	0.29	0.12	0.33	0.26
{1}	<b>0.7</b>	0.39	0.14	0.27	0.19

S	$\beta$	$r_1$	$r_2$	$r_3$	$r_4$
{1,2,3,4}	0.8	0.13	0.10	0.39	0.36
{1,2,3}	0.8	0.17	0.13	0.38	0.30
{1,2}	0.8	0.26	0.20	0.29	0.23
{1}	0.8	0.29	0.12	0.33	0.26

# Discovering the Topic Set S

- **Create different PageRanks for different topics**
  - The 16 DMOZ top-level categories:
    - Arts, Business, Sports,...
- **Which topic ranking to use?**
  - User can pick from a menu
  - Classify query into a topic
  - Can use the **context** of the query
    - E.g., query is launched from a web page talking about a known topic
    - History of queries e.g., “basketball” followed by “Jordan”
  - User context, e.g., user’s bookmarks, ...

# Application to Measuring Proximity in Graphs

---

**Random Walk with Restarts: set  $S$  is a single node**

# Proximity on Graphs

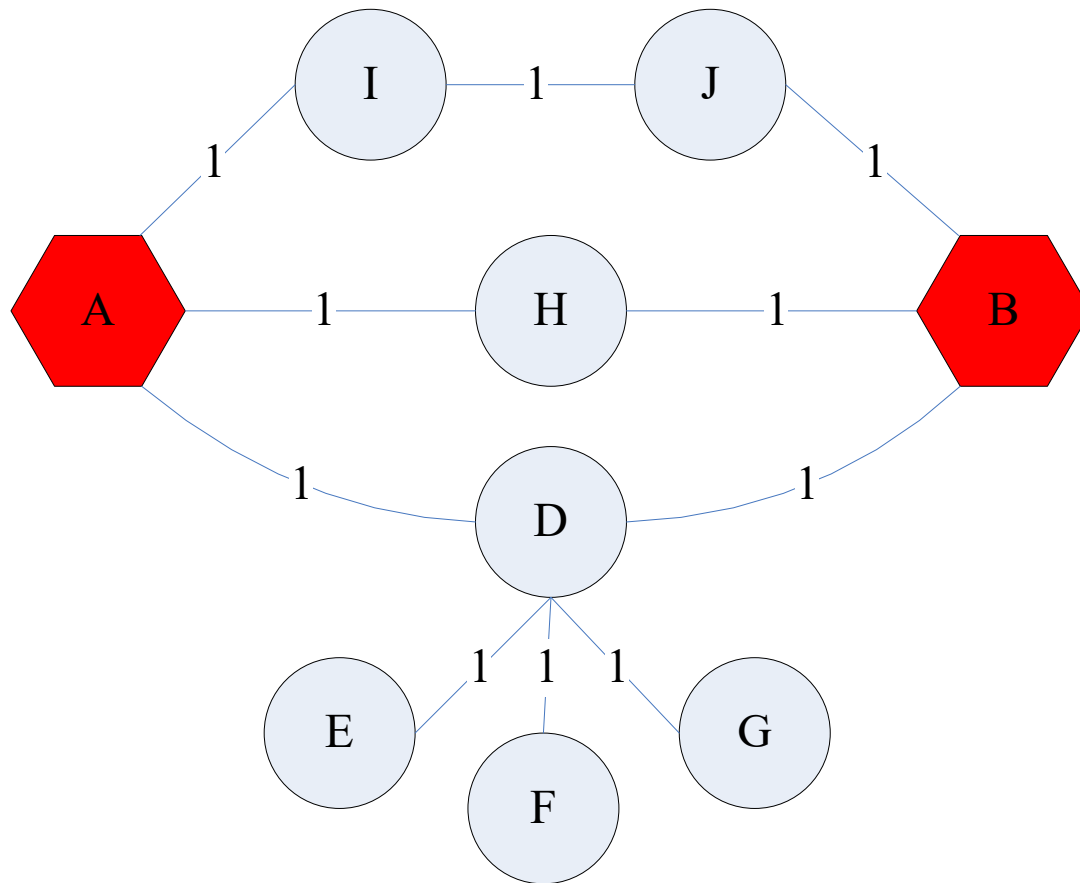

**a.k.a.: Relevance, Closeness, 'Similarity'...**

# Good proximity measure?

- **Shortest path is not good:**

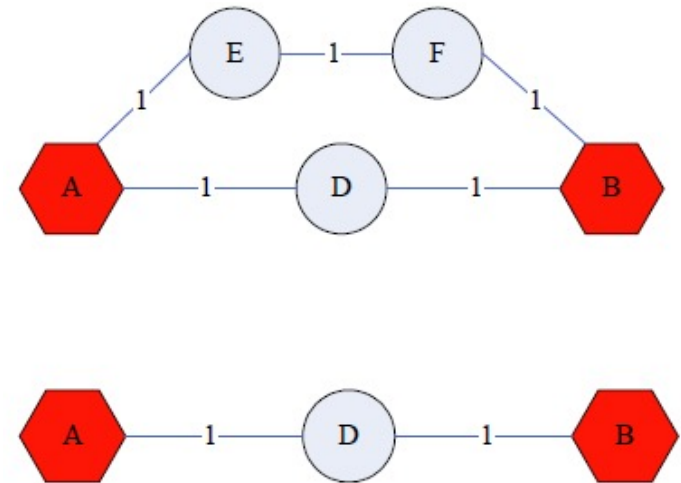
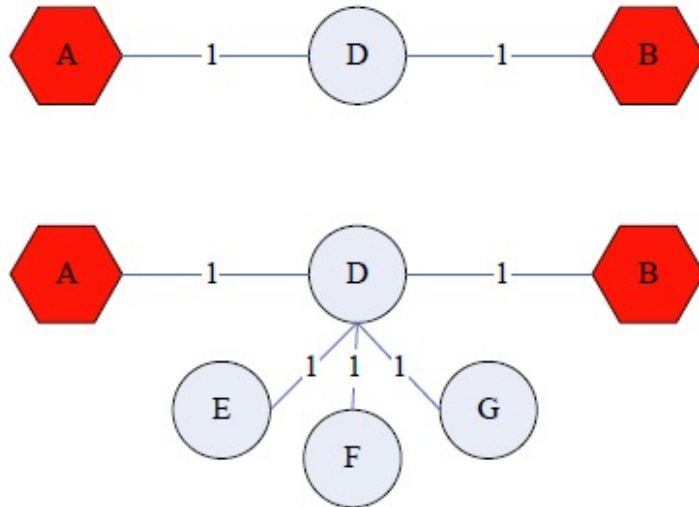

- **No effect of degree-1 nodes (E, F, G)!**
- Multi-faceted relationships

# Good proximity measure?

- Network flow is not good:

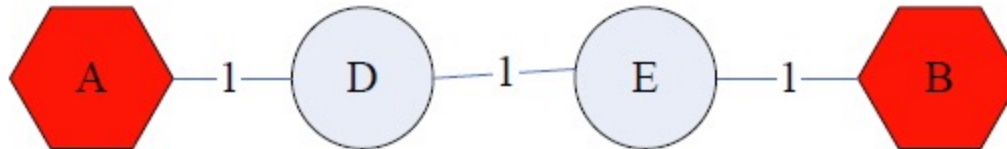
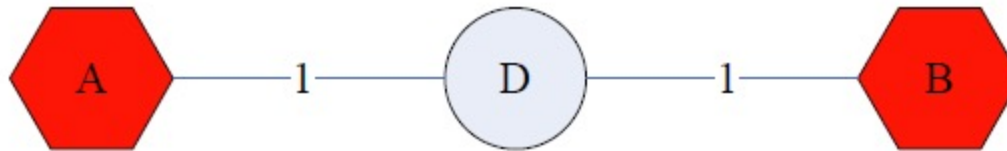

- Does not punish long paths

# What is a good notion of proximity?

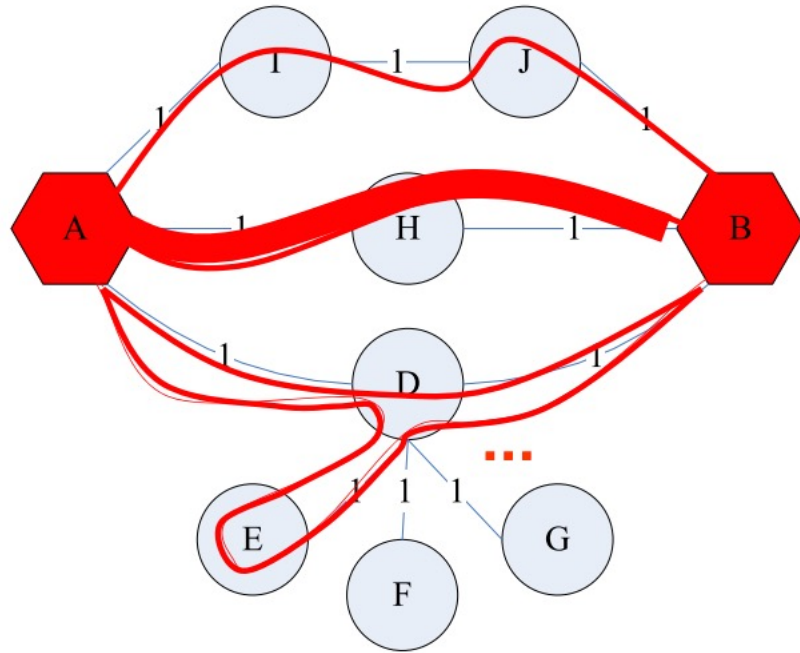

- **Need a method that considers:**

- Multiple connections
- Multiple paths
- Direct and indirect connections
- Degree of the node



# SimRank: Idea

- **SimRank:** Random walks from a **fixed node** on  $k$ -partite graphs
- **Setting:**  $k$ -partite graph with  $k$  types of nodes
  - E.g.: Authors, Conferences, Tags
- **Topic Specific PageRank** from node  $u$ : **teleport set**  $S = \{u\}$
- **Resulting scores measure similarity/proximity to node  $u$**
- **Problem:**
  - Must be done once for each node  $u$
  - Only suitable for sub-Web-scale applications

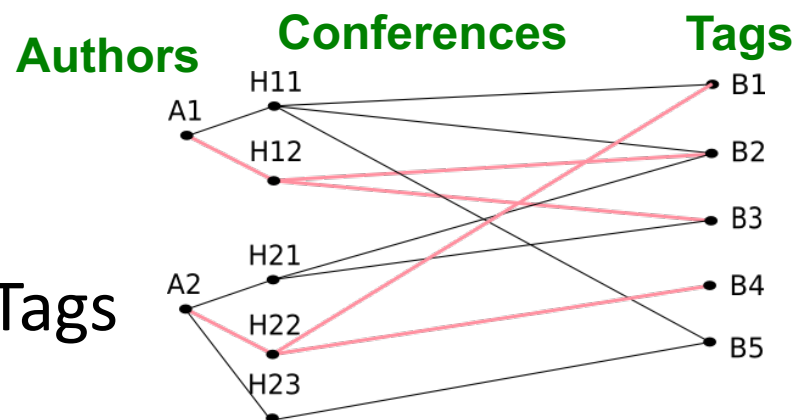

# SimRank: Example

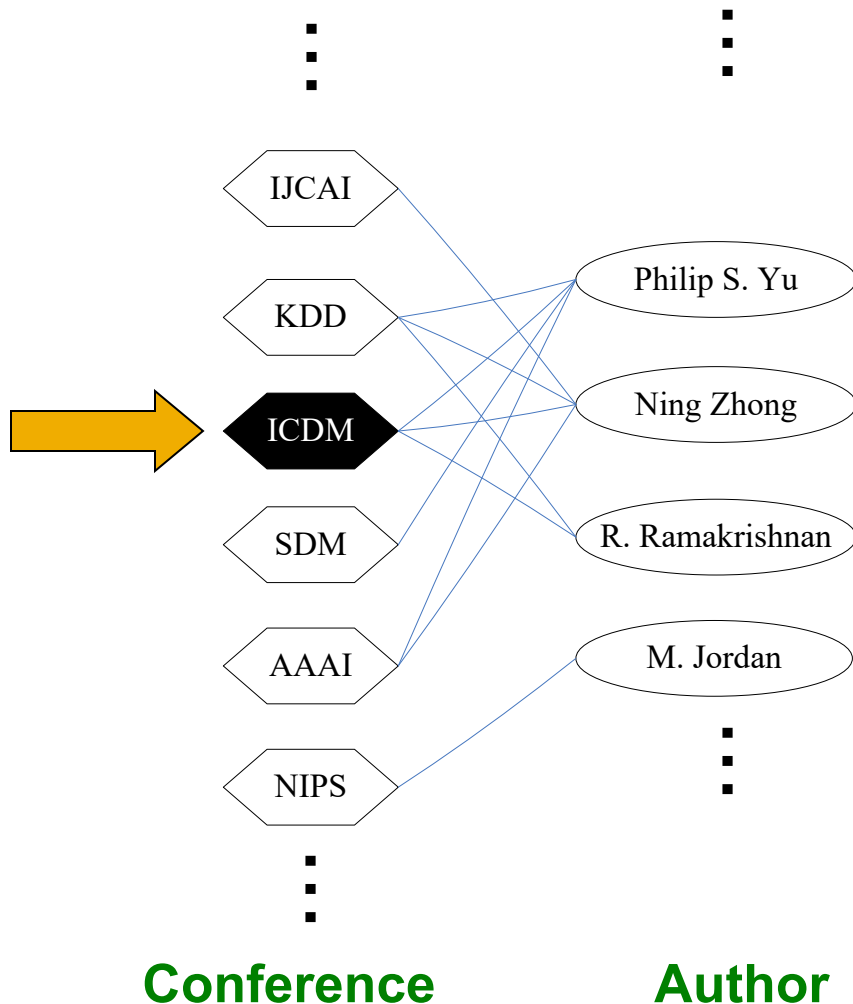

**Q:** What is the most related conference to **ICDM**?

**A:** Topic-Specific PageRank with teleport set  $S=\{\text{ICDM}\}$

# SimRank: Example

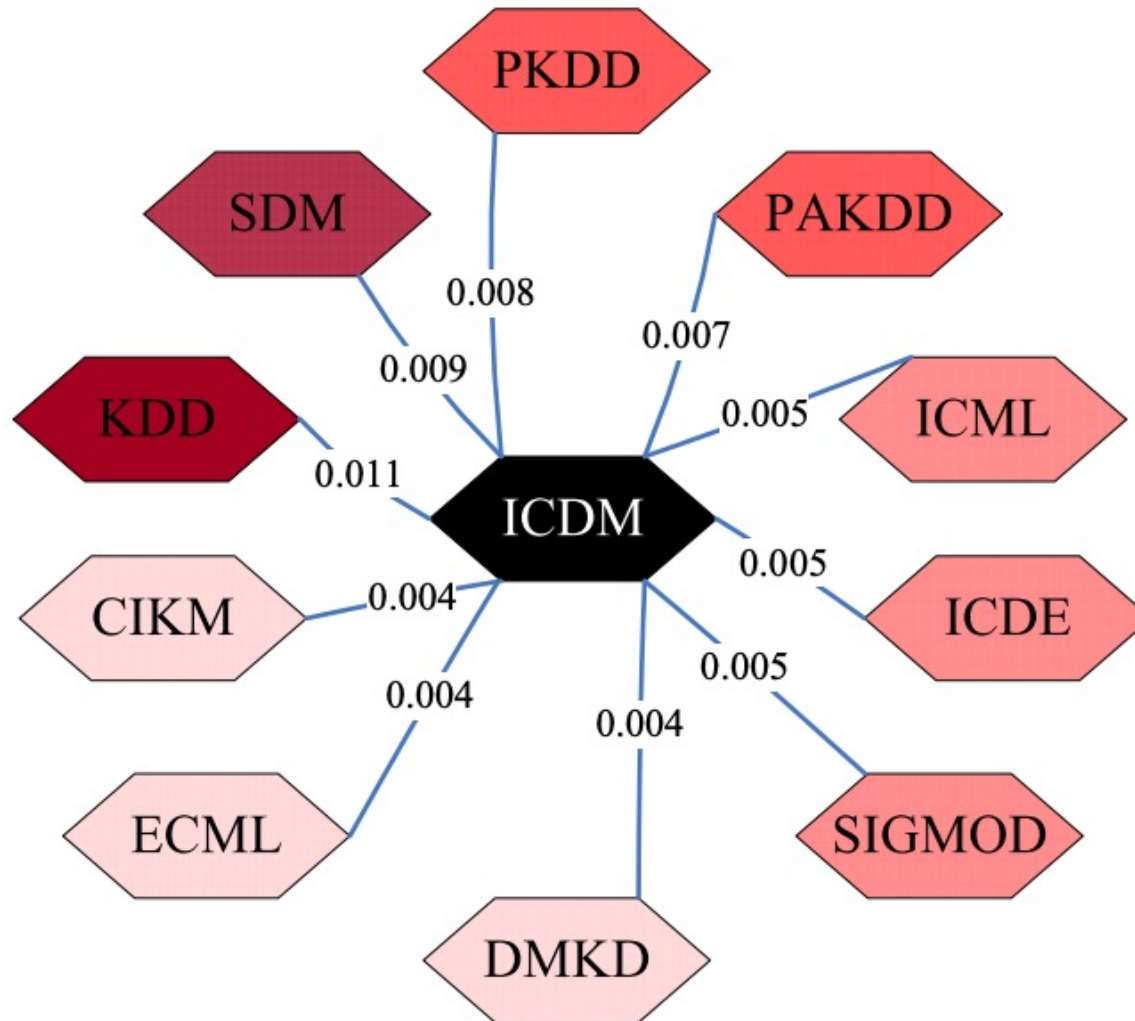

# Pinterest: Pins and Boards



**Pin**

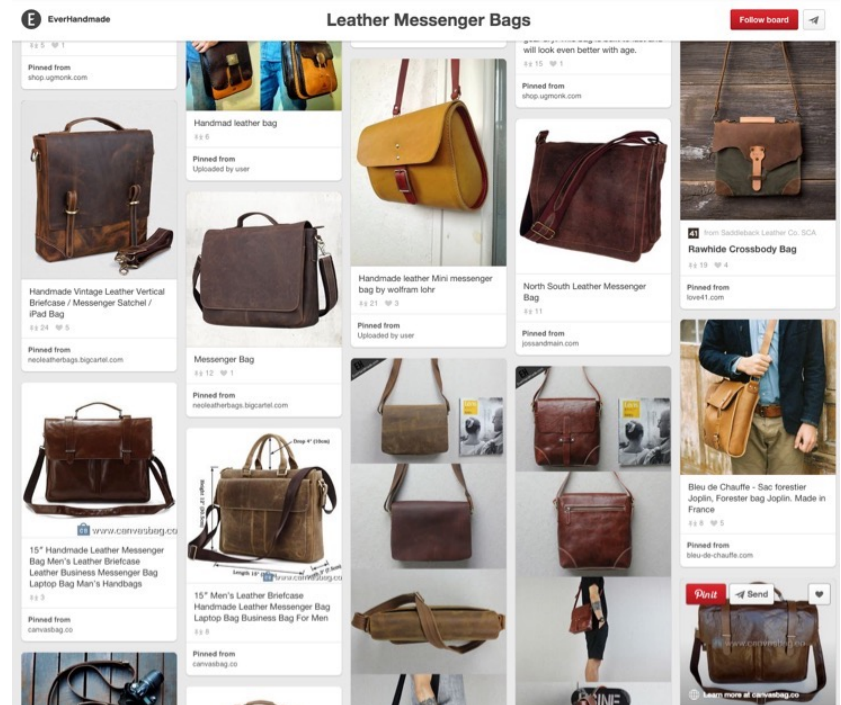
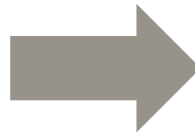

**Board**

# Pinterest is a Giant Bipartite Graph

- Pins belong to Boards

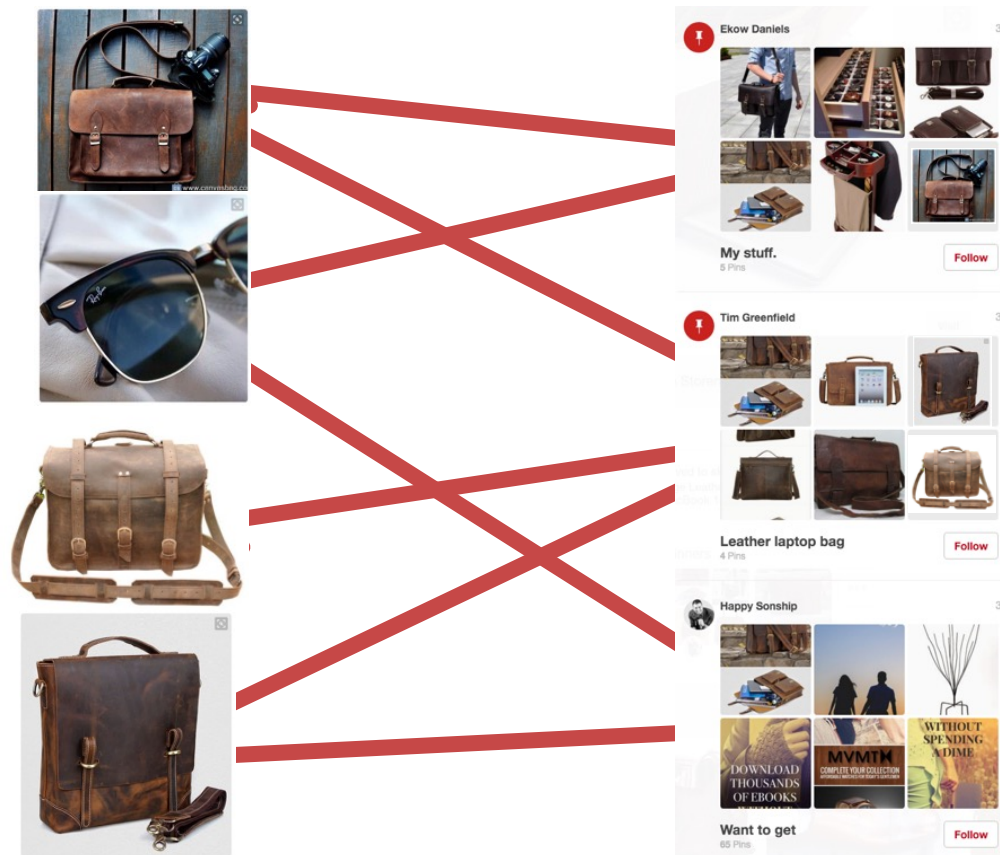

# Pins to Pins Recommendations

Input:



**Chocolate Strawberry Shake**

↑ 249

This healthier chocolate strawberry shake is like sipping a...

One Lovely Life



Danielle Benzaia  
Strawberries

# Pins to Pins Recommendations

Input: Recommendations:



**Chocolate Strawberry Shake** † 249  
 This healthier chocolate strawberry shake is like sipping a...  
 One Lovely Life  
 Danielle Benzaita Strawberries



**Chocolate Dipped Strawberry Smoothie** † 5.3k  
 Chocolate Dipped Strawberry Smoothie. Just in time for...  
 Be Whole. Be You.  
 Ed Todd Drinks- Smoothies



**Tropical Orange Smoothie**



**Easy Breezy Tropical Orange Smoothie** † 80.1k



**8 STAPLE SMOOTHIES**  
 (THAT YOU SHOULD KNOW HOW TO MAKE)

**8 Staple Smoothies You Should Know How to Make** † 5.2k  
 8 Staple Smoothies That You Should Know



**The Perfect Vanilla Pumpkin Smoothie: A Quick &...** † 11.4k

BabvSavers  
 Marybeth @ Bab... Best Comfort Fo...



**Spinach-Pear-Celery Smoothie** † 60  
 drink this daily and watch the pounds come off without fuss...  
 areenreset.com  
 Spring Stutzman R - Drink Up



# Pins to Pins Recommendations

## Input:



**Chocolate Strawberry Shake** † 249

This healthier chocolate strawberry shake is like sipping a...

One Lovely Life



Danielle Benzai  
Strawberries



**Healthy Chocolate Peanut Butter Chips Muffins** † 119

Healthy Chocolate Peanut Butter Chip Muffins made with greek...

The First Year



Katie - You Brew ...  
Healthy Recipes



**The Ultimate Healthy Soft & Chewy Chocolate Chip Cookies** † 221

The ULTIMATE Healthy Chocolate Chip Cookies -- so buttery...

Amy's Healthy Baking



Robin Guertin  
healthy cooking



# Pins to Pins Recommendations

Input:



**Chocolate Strawberry Shake** † 249

This healthier chocolate strawberry shake is like sipping a...

One Lovely Life

Danielle Benzaia Strawberries



**Healthy Chocolate Peanut Butter Chips Muffins** † 119

Healthy Chocolate Peanut Butter Chip Muffins made with greek...

The First Year

Katie - You Brew... Healthy Recipes



**The Ultimate Healthy Soft & Chewy Chocolate Chip Cookies** † 221

The ULTIMATE Healthy Chocolate Chip Cookies -- so buttery...

Amv's Healthy Baking

Robin Guertin healthy cooking

Recommendations:

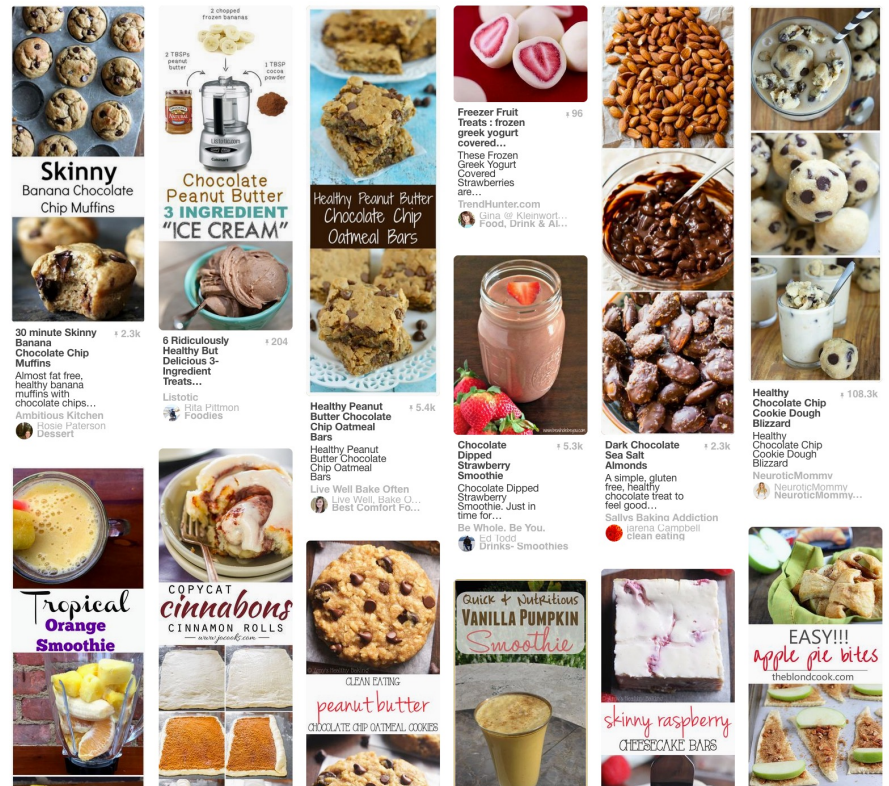

**Skinny Banana Chocolate Chip Muffins** † 2.3k

Almost fat free, healthy banana muffins with chocolate chips...

Ambitious Kitchen

Rose Patterson Unstap

**Chocolate Peanut Butter 3 INGREDIENT "ICE CREAM"** † 204

6 Ridiculously Healthy But Delicious 3-Ingredient Treats...

Listotic

Hila Pittman Foodies

**Healthy Peanut Butter Chocolate Chip Oatmeal Bars** † 5.4k

Healthy Peanut Butter Chocolate Chip Oatmeal Bars

Live Well Bake Often

Best Comfort Fo...

**Chocolate Dipped Strawberry Smoothie** † 5.3k

Chocolate Dipped Strawberry Smoothie. Just in time for...

Be Whole. Be You.

Ed Lodge Drinks+Smoothies

**Dark Chocolate Sea Salt Almonds** † 2.3k

A simple, gluten free, healthy chocolate treat to feel good...

salvia Baking Addiction

Jarena Campbell clean eating

**Healthy Chocolate Chip Cookie Dough Blizzard** † 108.3k

Healthy Chocolate Chip Cookie Dough Blizzard

NeuroticMommy

NeuroticMommy NeuroticMommy...

**Tropical Orange Smoothie**

**COPYCAT cinnabons CINNAMON ROLLS**

**peanut butter CHOCOLATE CHIP OATMEAL COOKIES**

**QUICK & Nutritious VANILLA PUMPKIN Smoothie**

**skinny raspberry CHEESECAKE BARS**

**EASY!!! apple pie bites**

theblondcook.com

# Bipartite Pin And Board Graph

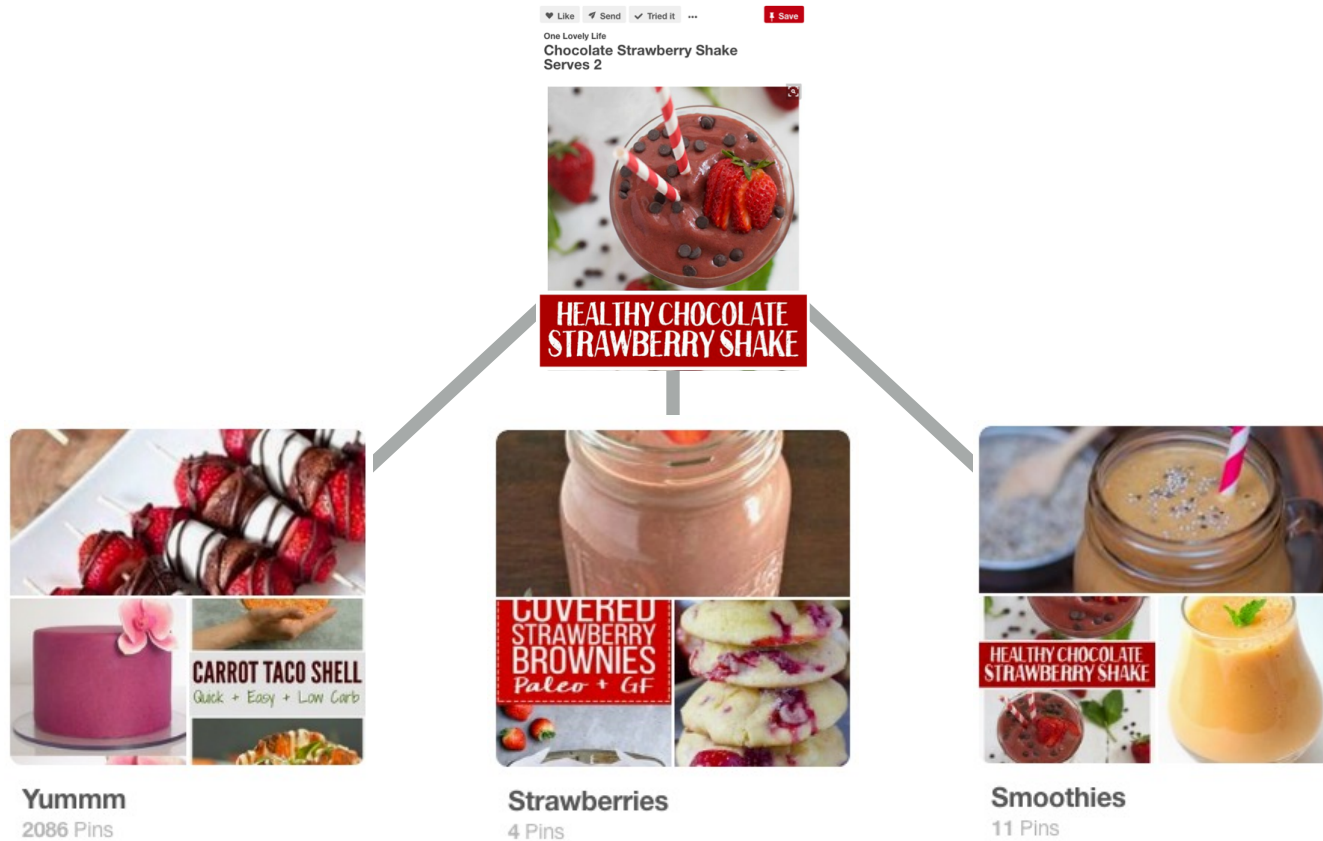

# Bipartite Pin And Board Graph

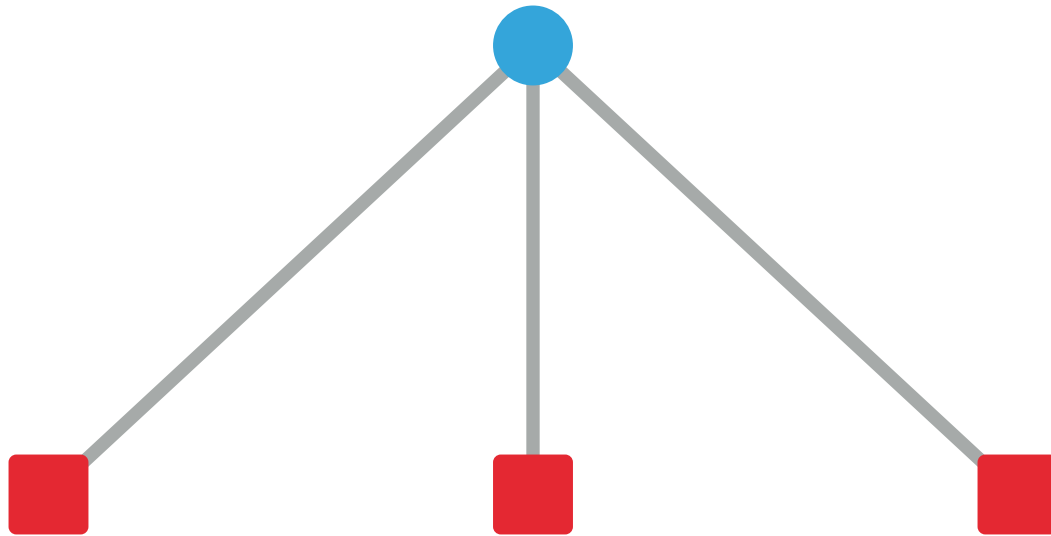

# Bipartite Pin And Board Graph

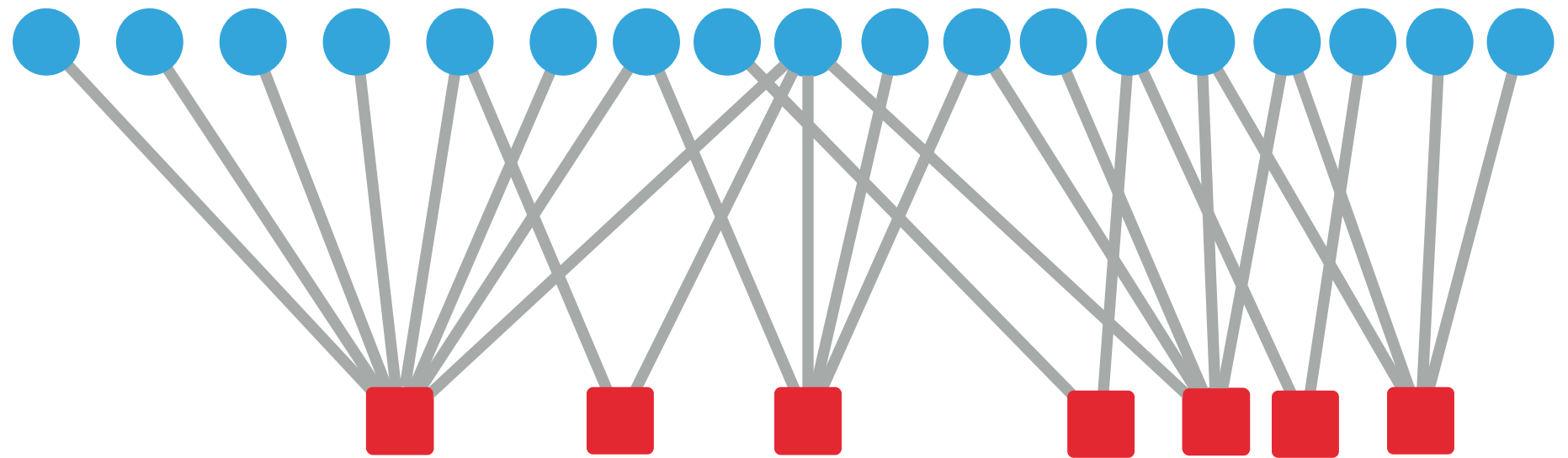

# Pixie Random Walks

- **Idea:**
  - Every node has some importance
  - Importance gets evenly split among all edges and pushed to the neighbors
- Given a set of QUERY NODES  $Q$ , simulate a random walk:

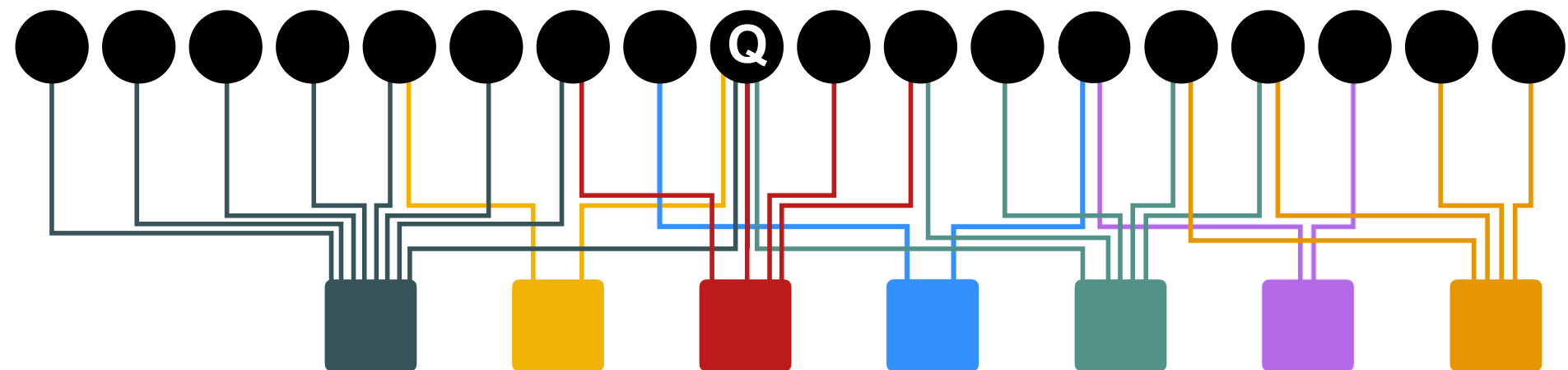

# Pixie Random Walk Algorithm

## ■ Proximity to query node(s) $Q$ :

ALPHA = 0.5

QUERY\_NODES =

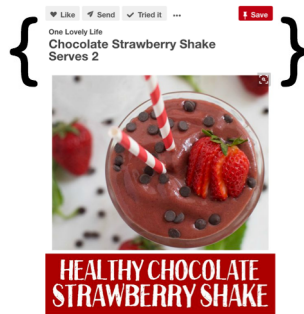

```
pin_node = QUERY_NODES.sample_by_weight()
```

```
for i in range(N_STEPS):
```

```
    board_node = pin_node.get_random_neighbor()
```

```
    pin_node = board_node.get_random_neighbor()
```

```
    pin_node.visit_count += 1
```

```
    if random() < ALPHA:
```

```
        pin_node = QUERY_NODES.sample_by_weight()
```

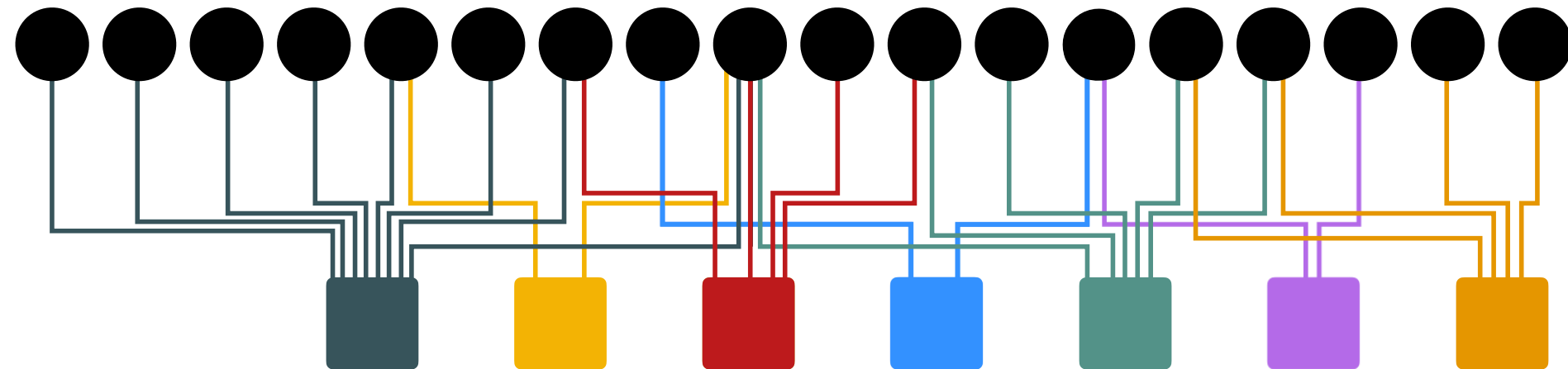

# Pixie Random Walk Algorithm

## ■ Proximity to query node(s) $Q$ :

ALPHA = 0.5

QUERY\_NODES =

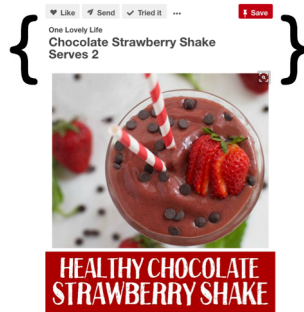

```
pin_node = QUERY_NODES.sample_by_weight()
```

```
for i in range(N_STEPS):
```

```
    board_node = pin_node.get_random_neighbor()
```

```
    pin_node = board_node.get_random_neighbor()
```

```
    pin_node.visit_count += 1
```

```
    if random() < ALPHA:
```

```
        pin_node = QUERY_NODES.sample_by_weight()
```

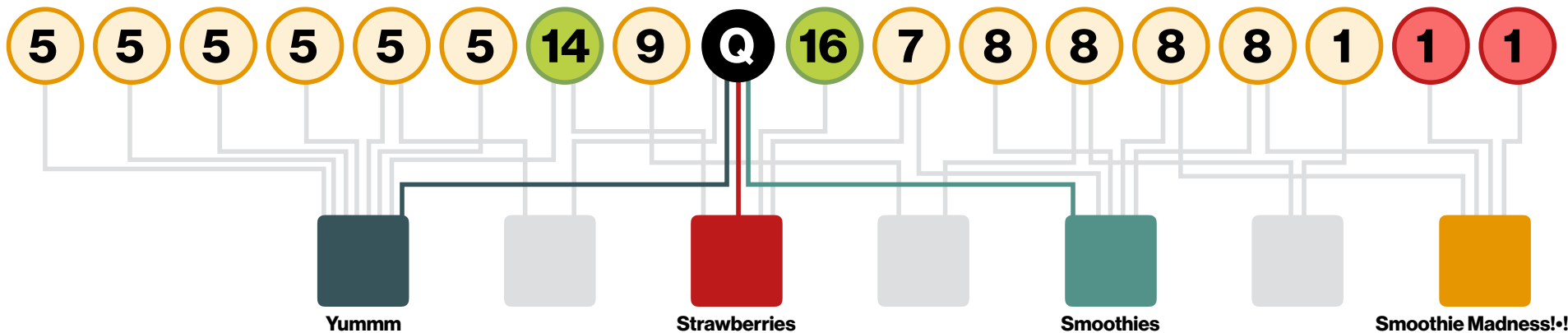

# Pixie Recommendations

- **Pixie:**

- **Outputs top 1k pins with highest visit count**

## **Extensions:**

- **Weighted edges:**

- The walk prefers to traverse certain edges:
  - Edges to pins in your local language

- **Early stopping:**

- Don't need to walk a fixed big number of steps
- Walk until 1k-th pin has at least 20 visits



# Graph Cleaning/Pruning

- **Pinterest graph has 200B edges**
- We don't need all of them!
  - Super popular pins are pinned to millions of boards
    - **Not useful:** When the random walk hits the pin, the signal just disperses. Such pins appear randomly in their recommendations.
- **What we did: Keep only good boards for pins**
  - Compute the similarity between pin's topic vector and each of its boards. Only take boards with high similarity.

Data Type	Number	Size	Memory
Pin Nodes	3 Billion	8 Bytes	24 GiB
Board Nodes	2 Billion	8 Bytes	16 GiB
Undirected Edges	20 Billion	8 Bytes	160 GiB
			208 GiB

# Benefits of Pixie

- **Benefits:**
  - **Very fast:** Given  $Q$ , we can output top 1k in 50ms (after doing 100k steps of the random walk)
  - Single machine can run 1500 walks in parallel! (1500 recommendation requests per second)
  - Can fit entire graph in RAM (17B edges, 3B nodes)
  - Can scale it by just adding more machines
- **Today about 70% of all the pins you see at Pinterest are recommended by random walks**

# PageRank: Summary

- **“Normal” PageRank:**
  - Teleports uniformly at random to any node
  - All nodes have the same probability of surfer landing there:  $\mathbf{S} = [0.1, 0.1, 0.1, 0.1, 0.1, 0.1, 0.1, 0.1, 0.1, 0.1]$
- **Topic-Specific PageRank also known as Personalized PageRank:**
  - Teleports to a topic specific set of pages
  - Nodes can have different probabilities of surfer landing there:  $\mathbf{S} = [0.1, 0, 0, 0.2, 0, 0, 0.5, 0, 0, 0.2]$
- **Random Walk with Restarts (e.g. SimRank):**
  - Topic-Specific PageRank where teleport is always to the same node.  $\mathbf{S} = [0, 0, 0, 0, \mathbf{1}, 0, 0, 0, 0, 0]$

# TrustRank: Combating Spam on the Web

---

# What is Web Spam?

- **Spamming:**
  - Any deliberate action to boost a web page's position in search engine results, incommensurate with the page's real value
- **Spam:**
  - Web pages that are the result of spamming
- This is a very broad definition
  - **SEO** industry might disagree!
  - SEO = search engine optimization
- Approximately **10-15%** of web pages are spam

# Web Search

- **Early search engines:**
  - Crawl the Web
  - Index pages by the words they contained
  - Respond to search queries (lists of words) with the pages containing those words
- **Early page ranking:**
  - Attempt to order pages matching a search query by “importance”
  - **First search engines considered:**
    - (1) Number of times query words appeared
    - (2) Prominence of word position, e.g. title, header

# First Spammers

- As people began to use search engines to find things on the Web, those with commercial interests tried to **exploit search engines** to bring people to their own site – whether they wanted to be there or not
- **Example:**
  - Shirt-seller might pretend to be about “movies”
- **Techniques for achieving high relevance/importance for a web page**

# First Spammers: Term Spam

- **How do you make your page appear to be about movies?**
  - **(1)** Add the word movie 1,000 times to your page
    - Set text color to the background color, so only search engines would see it
  - **(2)** Or, run the query “movie” on your target search engine
    - See what page came on top of result ranking
    - Copy it into your page, make it “invisible”
- **These and similar techniques are term spam**



# Google's Solution to Term Spam

- **Believe what people say about you, rather than what you say about yourself**
  - Use words in the anchor text (words that appear underlined to represent the link) and its surrounding text
- **PageRank as a tool to measure the “importance” of Web pages**

# Why It Works?

- **Our hypothetical shirt-seller loses**
  - Saying he is about movies doesn't help, because others don't say he is about movies
  - His page isn't very important, so it won't be ranked high for shirts or movies
- **Example:**
  - Shirt-seller creates 1,000 pages, each links to his with "movie" in the anchor text
  - These pages have no links in, so they get little PageRank
  - So the shirt-seller can't beat truly important movie pages, like IMDB

# Why does it not work?

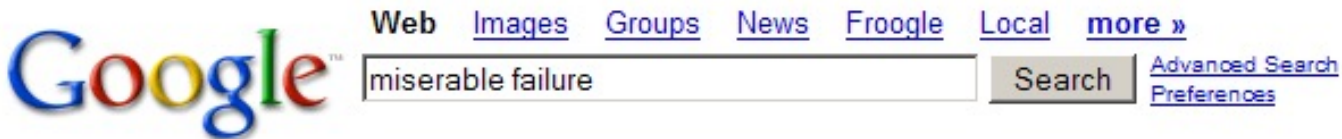

**Web**

Results 1 - 10 of about 969,000 for [miserable failure](#). (0.06 seconds)

## [Biography of President George W. Bush](#)

Biography of the president from the official White House web site.

[www.whitehouse.gov/president/gwbbio.html](http://www.whitehouse.gov/president/gwbbio.html) - 29k - [Cached](#) - [Similar pages](#)

[Past Presidents](#) - [Kids Only](#) - [Current News](#) - [President](#)

[More results from www.whitehouse.gov »](#)

## [Welcome to MichaelMoore.com!](#)

Official site of the gadfly of corporations, creator of the film Roger and Me and the television show The Awful Truth. Includes mailing list, message board, ...

[www.michaelmoore.com/](http://www.michaelmoore.com/) - 35k - [Sep 1, 2005](#) - [Cached](#) - [Similar pages](#)

## [BBC NEWS | Americas | 'Miserable failure' links to Bush](#)

Web users manipulate a popular search engine so an unflattering description leads to the president's page.

[news.bbc.co.uk/2/hi/americas/3298443.stm](http://news.bbc.co.uk/2/hi/americas/3298443.stm) - 31k - [Cached](#) - [Similar pages](#)

## [Google's \(and Inktomi's\) Miserable Failure](#)

A search for **miserable failure** on Google brings up the official George W.

Bush biography from the US White House web site. Dismissed by Google as not a ...

[searchenginewatch.com/sereport/article.php/3296101](http://searchenginewatch.com/sereport/article.php/3296101) - 45k - [Sep 1, 2005](#) - [Cached](#) - [Similar pages](#)



# SPAM FARMING

# Google vs. Spammers: Round 2!

- Once Google became the dominant search engine, spammers began to work out ways to fool Google
- **Spam farms** were developed to concentrate PageRank on a single page
- **Link spam:**
  - Creating link structures that boost PageRank of a particular page



# Link Spamming

- **Three kinds of web pages from a spammer's point of view**
  - **Inaccessible pages**
  - **Accessible pages**
    - e.g., blog comments pages
    - spammer can post links to his pages
  - **Owned pages**
    - Completely controlled by spammer
    - May span multiple domain names

# Link Farms

- **Spammer's goal:**
  - Maximize the PageRank of target page  $t$
- **Technique:**
  - Get as many links from accessible pages as possible to target page  $t$
  - Construct “link farm” to get PageRank multiplier effect (next)

# Link Farms

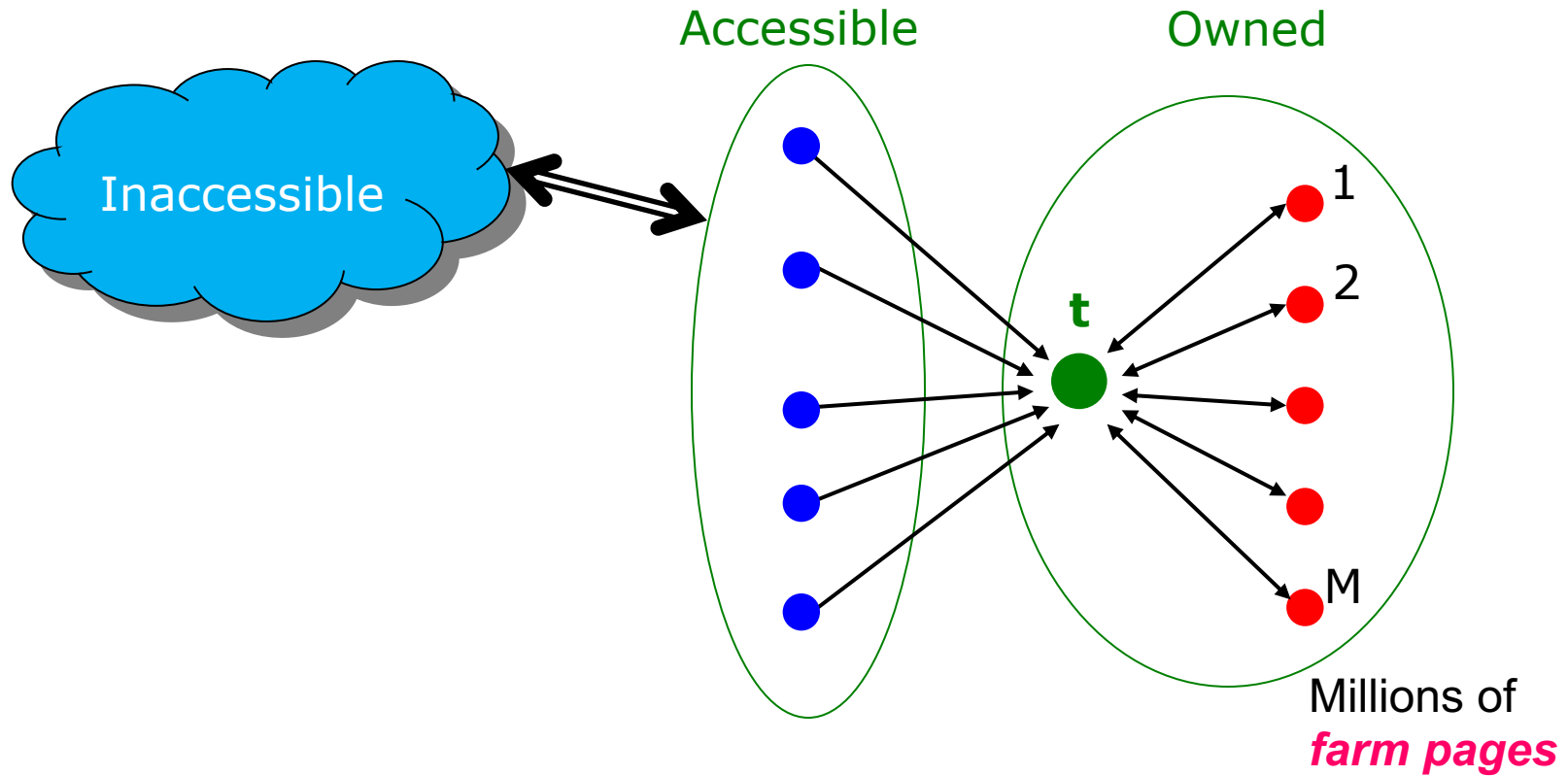

**One of the most common and effective organizations for a link farm**



# Analysis

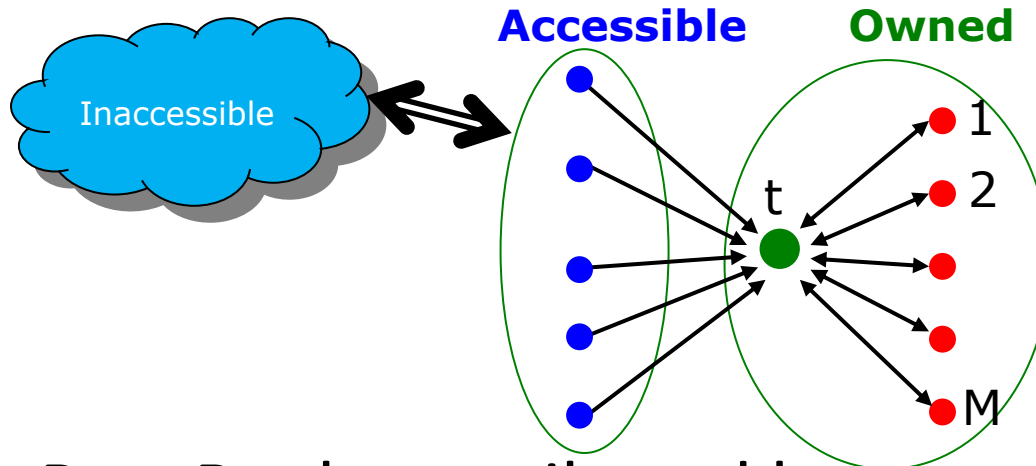

N...# pages on the web  
M...# of pages spammer owns

- $x$ : PageRank contributed by **accessible pages**
- $y$ : PageRank of target page  $t$

- Rank of each “farm” page =  $\frac{\beta y}{M} + \frac{1-\beta}{N}$

- $$y = x + \beta M \left[ \frac{\beta y}{M} + \frac{1-\beta}{N} \right] + \frac{1-\beta}{N}$$

$$= x + \beta^2 y + \frac{\beta(1-\beta)M}{N} + \frac{1-\beta}{N}$$

Very small; ignore  
Now we solve for  $y$

- $$y = \frac{x}{1-\beta^2} + c \frac{M}{N} \quad \text{where } c = \frac{\beta}{1+\beta}$$

# Analysis

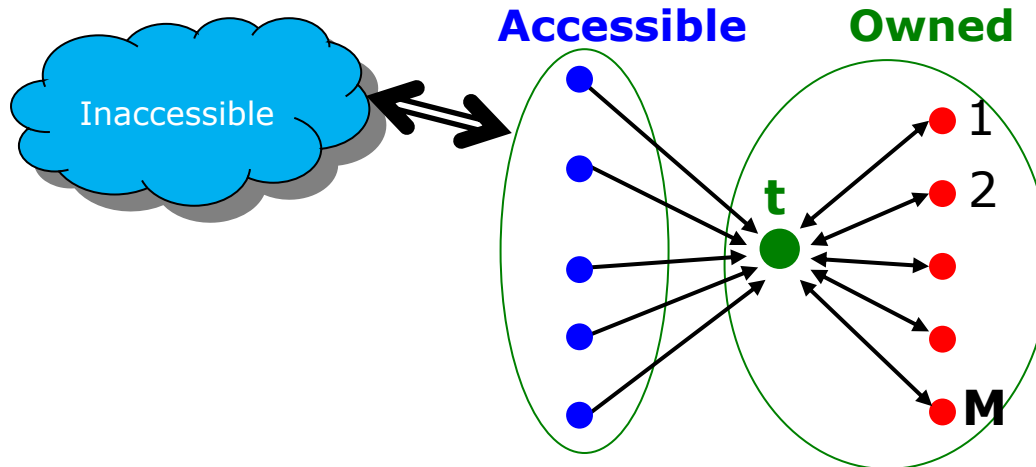

$N$ ...# pages on the web  
 $M$ ...# of pages spammer owns

- $y = \frac{x}{1-\beta^2} + c \frac{M}{N}$  where  $c = \frac{\beta}{1+\beta}$

- For  $\beta = 0.85$ ,  $1/(1-\beta^2) = 3.6$

- Multiplier effect for acquired PageRank

- By making  $M$  large, we can make  $y$  as large as we want

# TrustRank: Combating Spam on the Web

---

# Combating Spam

## ■ Combating term spam

- Analyze text using statistical methods
- Similar to email spam filtering
- Also useful: Detecting approximate duplicate pages

## ■ Combating link spam

- **Detection and blacklisting of structures that look like spam farms**
  - Leads to another war – hiding and detecting spam farms
- **TrustRank** = topic-specific PageRank with a teleport set of **trusted pages**
  - **Example:** .edu domains, similar domains for non-US schools

# TrustRank: Idea

- **Basic principle: Approximate isolation**
  - It is rare for a “good” page to point to a “bad” (spam) page
- Sample a set of **seed pages** from the web
- Have an **oracle (human)** to identify the good pages and the spam pages in the seed set
  - **Expensive task**, so we must make seed set as small as possible

# Trust Propagation

- Call the subset of seed pages that are identified as **good** the **trusted pages**
- Perform a topic-sensitive PageRank with **teleport set = trusted pages**
  - **Propagate trust through links:**
    - Each page gets a trust value between **0** and **1**
- **Solution 1: Use a threshold value and mark all pages below the trust threshold as spam**

# Simple Model: Trust Propagation

- **Set trust of each trusted page to 1**
- Suppose trust of page  $p$  is  $t_p$ 
  - Page  $p$  has a set of out-links  $o_p$
- For each  $q \in o_p$ ,  $p$  **confers the trust** to  $q$ 
  - $\beta t_p / |o_p|$  for  $0 < \beta < 1$
- **Trust is additive**
  - Trust of  $p$  is the sum of the trust conferred on  $p$  by all its in-linked pages
- **Note similarity to Topic-Specific PageRank**
  - Within a scaling factor, **TrustRank = PageRank** with trusted pages as teleport set

# Why is it a good idea?

- **Trust is additive**

- Sum up trust from pages linking to target page

- **Trust splitting:**

- The larger the number of out-links from a page, the less scrutiny the page author gives each out-link
- Trust is **split** across out-links

- **Trust attenuation:**

- The degree of trust conferred by a trusted page decreases with the distance in the graph



# Picking the Seed Set

- **Two conflicting considerations:**
  - **Cost:** Human has to inspect each seed page, so seed set must be as small as possible
  - **Coverage:** Must ensure every good page gets adequate trust rank, so need make all good pages reachable from seed set by short paths

# Approaches to Picking Seed Set

- Suppose we want to pick a seed set of  $k$  pages
- **How to do that?**
- **(1) PageRank:**
  - Pick the top  $k$  pages by PageRank
  - Theory is that you can't get a bad page's rank really high
- **(2) Use trusted domains** whose membership is controlled, like .edu, .mil, .gov

# TrustRank

---

# Spam Mass

- In the **TrustRank** model, we start with good pages and propagate trust
- **Complementary view:**  
What fraction of a page's PageRank comes from **spam** pages?
- In practice, we don't know all the spam pages, so we need to estimate

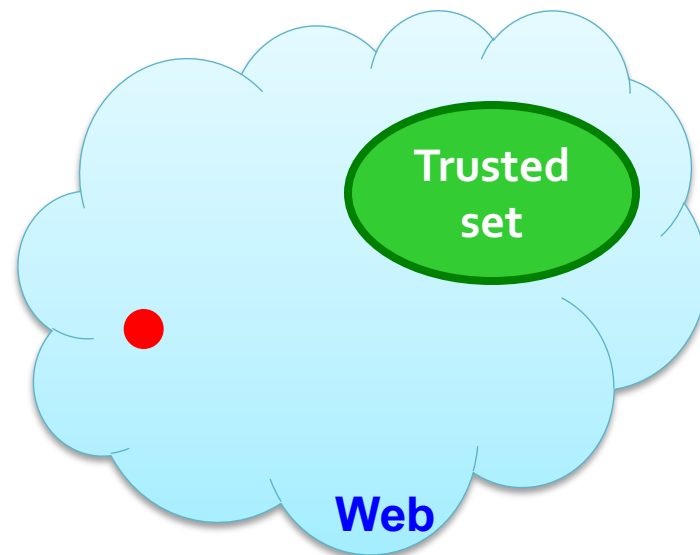

# Spam Mass Estimation

## Solution 2:

- $r_p$  = PageRank of page  $p$
- $r_p^+$  = PageRank of  $p$  with teleport into **trusted** pages only
- **Then:** What fraction of a page's PageRank comes from **spam** pages?

$$r_p^- = r_p - r_p^+$$

- **Spam mass of  $p$**  =  $\frac{r_p^-}{r_p}$ 
  - Pages with high spam mass are spam; can filter them out

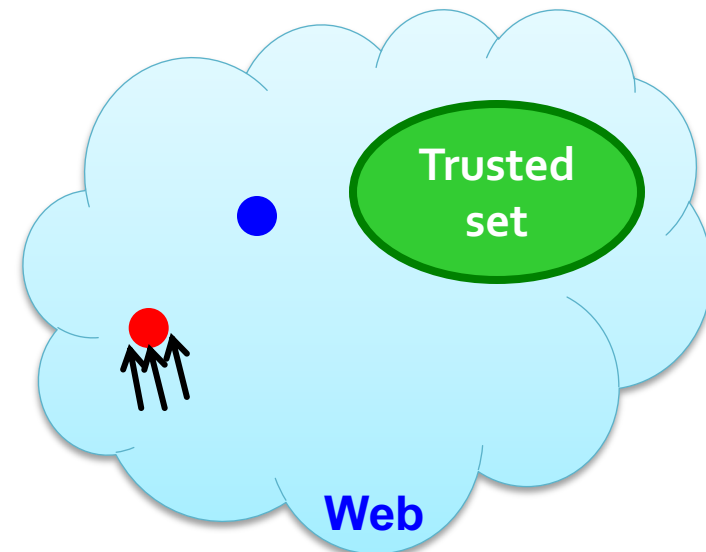

Please give us feedback 😊

<https://bit.ly/547feedback>