

- PERMANENT MAGNET STEPPER AND GEARED MOTORS •
- DIGITAL LINEAR ACTUATORS • BRUSHLESS DC MOTORS •

# PRODUCT SELECTION AND ENGINEERING GUIDE

- CUSTOMIZATION TO MEET YOUR PRECISE DESIGN NEEDS
- FAST, POWERFUL, PRECISE POSITIONING
- LARGE SELECTION OF PERMANENT MAGNET STEPPER MOTORS – FROM 15MM TO 60MM
- PIONEER IN DIGITAL LINEAR TECHNOLOGY
- STEP ANGLE RANGE FROM 1.8° TO 18°



**THOMSON**  
AIRPAX MECHATRONICS

All Thomson Industries Manufacturing Locations are  
ISO 9000 Certified and Automotive Facilities  
Operate to QS-9000 Standards  
General Motors Supplier of the Year Since 1995

ISO 9000

# Table of Contents

<b>Stepper Motor Technology</b>	<b>Page 2 - 9</b>
---------------------------------	-------------------

The stepper motor is a device used to convert electrical pulses into discrete mechanical rotational movements.

<b>Application Notes</b>	<b>Page 10 - 11</b>
--------------------------	---------------------

These application notes should be an aid in selecting the best stepper motor for your specific needs.

<b>Handy Formulas</b>	<b>Page 12 - 13</b>
-----------------------	---------------------

Primary units in this guide are metric (SI - the International System of units).

<b>Product Overview</b>	<b>Page 14</b>
-------------------------	----------------

<b>Application Chart</b>	<b>Page 15</b>
--------------------------	----------------

<b>Stepper Motor Quick Reference Chart</b>	<b>Page 16</b>
--	----------------

<b>Stepper Motors</b>	<b>Page 17</b>
	<b>Series 15M020D</b>

**Holding Torque: mN•m/oz-in**  
3.88/1.55  
**Step Angle** 18.0°

<b>Stepper Motors</b>	<b>Page 18</b>
	<b>Series 26M048B</b>

**Holding Torque: mN•m/oz-in**  
Unipolar 9.2/1.3 Bipolar 10.6/1.5  
**Step Angle** 7.5°

<b>Stepper Motors</b>	<b>Page 19</b>
	<b>Series 26M024B</b>

**Holding Torque: mN•m/oz-in**  
Unipolar 4.9/0.7 Bipolar 7.1/1.0  
**Step Angle** 15°

<b>Stepper Motors</b>	<b>Page 20</b>
	<b>Series 35M048B 35M024B 35M020B</b>

**Holding Torque: mN•m/oz-in**  
Unipolar 18.4/2.6, 16.93/2.4, 13.4/1.9  
**Step Angle** 7.5°, 15.0°, 18.0°

<b>Stepper Motors</b>	<b>Page 21</b>
	<b>Series 35L048B 35L024B 35L020B</b>

**Holding Torque: mN•m/oz-in**  
Unipolar 27.5/3.9, 21.1/3.0, 17.7/2.5  
**Step Angle** 7.5°, 15.0°, 18.0°

<b>Stepper Motors</b>	<b>Page 22</b>
	<b>Series 42M048C</b>

**Holding Torque: mN•m/oz-in**  
Unipolar 73.4/10.4 Bipolar 87.5/12.4  
**Step Angle** 7.5°

<b>Stepper Motors</b>	<b>Page 23</b>
	<b>Series 42M100B</b>

**Holding Torque: mN•m/oz-in**  
Unipolar 45.2/6.4 Bipolar 49.4/7.0  
**Step Angle** 3.6°

<b>Stepper Motors</b>	<b>Page 24</b>
	<b>Series 57L048B 57M024B 57M048B</b>

**Holding Torque: mN•m/oz-in**  
Unipolar 205/25.0, 55/7.8, 74/10.5  
**Step Angle** 7.5°, 15°

<b>Stepper Motors</b>	<b>Page 25</b>
	<b>Series 60L048B 60L024B</b>

**Holding Torque: mN•m/oz-in**  
Unipolar 198/28, 141/20  
**Step Angle** 7.5°, 15°

<b>Stepper Motors</b>	<b>Page 26</b>
	<b>Series 4SQ</b>

**Holding Torque: mN•m/oz-in**  
Unipolar 65/9.2  
**Step Angle** 1.8°

For information or to place an order in North America: 1 (203) 271-6444 Europe: (44) 1276-691622 Asia: (65) 7474-888



The specifications in this publication are believed to be accurate and reliable. However, it is the responsibility of the product user to determine the suitability of Thomson products for a specific application. While defective products will be replaced without charge if promptly returned, no liability is assumed beyond such replacement.

# Table of Contents

**Stepper Motors** Page 27



Series  
4SHG

Holding Torque: mN•m/oz-in  
Unipolar 388/55, 600/85  
Step Angle 1.8°

**Stepper Motors** Page 28



Series  
26M048B  
With  
Gear Trains  
(Type V)

Gear Train Rating:  
141.2 mN•m/20 oz-in static  
70.6 mN•m/10 oz-in running

**Stepper Motors** Page 29



Series  
35M048B  
With  
Gear Trains  
(Type X)

Gear Train Rating:  
141.2 mN•m/20 oz-in static  
35.3 mN•m/5.0 oz-in running

**Stepper Motors** Page 30



Series  
42M048C  
With  
Gear Trains  
(Type R)

Gear Train Rating:  
1.06 N•m/150 oz-in static  
0.706 N•m/100 oz-in running

**Stepper Motors** Page 31



Series  
42M048C  
With  
Gear Trains  
(Type Z)

Gear Train Rating:  
2.12 N•m/300 oz-in static  
1.41 N•m/200 oz-in running

**Stepper Motor Terminology** Page 32

**Introduction to Digital Linear Actuators** Page 33

**Digital Linear Actuators** Page 34-35



Series  
K92100  
L92100

Min Holding Force: 60 oz @ .001 in  
Linear Travel per step: .001", .002", & .004"

**Digital Linear Actuators** Page 36-37



Series  
K92200  
L92200

Min Holding Force: 40 oz @ .001 in  
Linear Travel per step: .001", .002", & .003"

**Digital Linear Actuators** Page 38-39



Series  
L92400

Min Holding Force: >20 lb  
Linear Travel per step: .001" & .002"

**Brushless DC Motors** Page 40



Series  
58MD036000

58mm Motor will be available in 1999.

**Brushless DC Motors** Page 40



Series  
98MD036000

98mm Motor will be available in 1999.

**Motion Control Solutions From Thomson Industries** Page 41



TMC-2000  
Motion  
Controller

**AXI-PAK\* Complete Servo Axis Packages**



**OMNIDRIVE\* Digital Servo Drives**



**BLX Brushless Servo Motors**



For information or to place an order in North America: 1 (203) 271-6444 Europe: (44) 1276-691622 Asia: (65) 7474-888

\*Trademark of Thomson Industries, Inc. THOMSON is registered in the U.S. Patent and Trademark Office and in other countries. The specifications in this publication are believed to be accurate and reliable. However, it is the responsibility of the product user to determine the suitability of Thomson products for a specific application. While defective products will be replaced without charge if promptly returned, no liability is assumed beyond such replacement.

# Stepper Motor Technology

The stepper motor is a device used to convert electrical pulses into discrete mechanical rotational movements.

The Thomson Airpax Mechatronics stepper motors described in this guide are 2-phase permanent magnet (PM) motors which provide discrete angular movement every time the polarity of a winding is changed.

## CONSTRUCTION

In a typical motor, electrical power is applied to two coils. Two stator cups formed around each of these coils, with pole pairs mechanically displaced by 1/2 a pole pitch, become alternately energized North and South magnetic poles. Between the two stator-coil pairs, the displacement is 1/4 of a pole pitch.

The permanent magnet rotor is magnetized with the same number of pole pairs as contained by the stator-coil section.

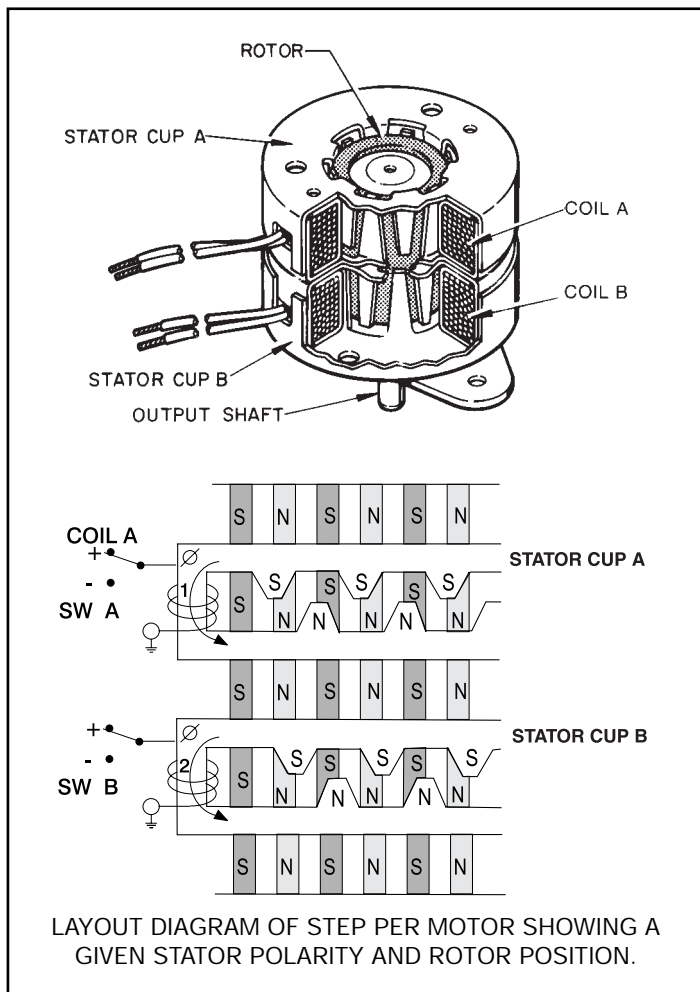

Figure 1: Cutaway 2Ø — Permanent Magnet Stepper Motor.

Interaction between the rotor and stator (opposite poles attracting and likes repelling) causes the rotor to move 1/4 of a pole pitch per winding polarity change. A 2-phase motor with 12 pole pairs per stator-coil section would thus move 48 steps per revolution or 7.5° per step.

## ELECTRICAL INPUT

The normal electrical input is a 4-step switching sequence as is shown in Figure 2.

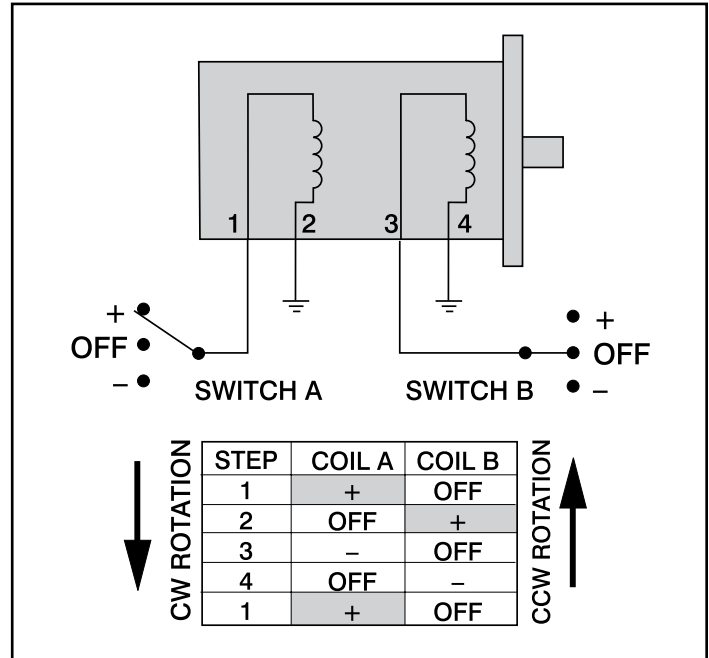

Figure 2: Schematic — 4-Step Switching Sequence.

Continuing the sequence causes the rotor to rotate forward. Reversing the sequence reverses the direction of rotation. Thus, the stepper motor can be easily controlled by a pulse input drive which can be a 2-flip-flop logic circuit operated either open or closed loop. Operated at a fixed frequency, the electrical input to the motor is a 2-phase 90° shifted square wave as shown below in Fig. 3.

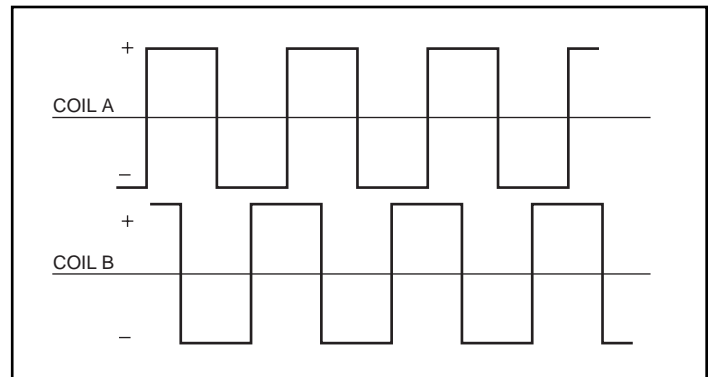

Figure 3: Voltage Wave Form — Fixed Frequency — 4-Step Sequence.

Since each step of the rotor can be controlled by a pulse input to a drive circuit, the stepper motor used with modern digital circuits, microprocessors and transistors provides accurate speed and position control along with long life and reliability.

For information or to place an order in North America: 1 (203) 271-6444 Europe: (44) 1276-691622 Asia: (65) 7474-888

## STEP ANGLE

Step angles for steppers are available in a range from .72° to 90°. Standard step angles for Thomson Airpax steppers are:

- 3.6° — 100 steps per rev.
- 7.5° — 48 steps per rev.
- 15° — 24 steps per rev.
- 18° — 20 steps per rev.

A movement of any multiple of these angles is possible. For example, six steps of a 15° stepper motor would give a movement of 90°.

## ACCURACY

A 7.5° stepper motor, either under a load or no load condition, will have a step-to-step accuracy of 6.6% or 0.5°. This error is non-cumulative so that even after making a full revolution, the position of the rotor shaft will be  $360^\circ \pm 0.5^\circ$ .

The step error is noncumulative. It averages out to zero within a 4-step sequence which corresponds to 360 electrical degrees. A particular step characteristic of the 4-step is to sequence repeatedly using the same coil, magnetic polarity and flux path. Thus, the most accurate movement would be to step in multiples of four, since electrical and magnetic imbalances are eliminated. Increased accuracy also results from movements which are multiples of two steps. Keeping this in mind, positioning applications should use 2 or 4 steps (or multiples thereof) for each desired measured increment, wherever possible.

## TORQUE

The torque produced by a specific stepper motor depends on several factors:

- 1/ The Step Rate
- 2/ The Drive Current Supplied to the Windings
- 3/ The Drive Design

## HOLDING TORQUE

At standstill (zero steps/sec and rated current), the torque required to deflect the rotor a full step is called the *holding torque*. Normally, the holding torque is higher than the running torque and, thus, acts as a strong brake in holding a load. Since deflection varies with load, the higher the holding torque the more accurate the position will be held. Note in the curve below in Fig. 4, that a 2-step deflection corresponding to a phase displacement of 180, results in zero torque. A 1-step plus or minus displacement represents the initial lag that occurs when the motor is given a step command.

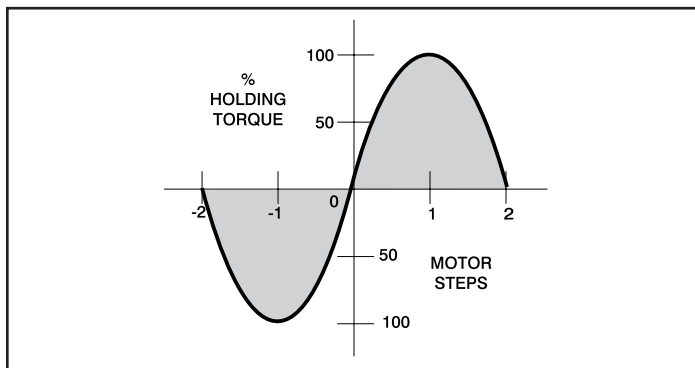

Figure 4: Torque Deflection.

## RESIDUAL TORQUE

The non-energized detent torque of a permanent magnet stepper motor is called *residual torque*. A result of the permanent magnet flux and bearing friction, it has a value of approximately 1/10 the holding torque. This characteristic of PM steppers is useful in holding a load in the proper position even when the motor is de-energized. The position, however, will not be held as accurately as when the motor is energized.

## DYNAMIC TORQUE

A typical torque versus step rate (speed) characteristic curve is shown in Figure 5.

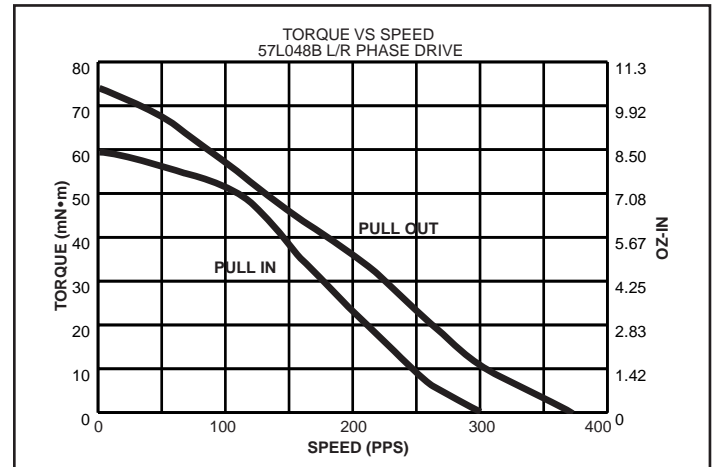

Figure 5: Torque/Speed — (Thomson Airpax 57L048B L/R Stepper).

The *PULL IN* curve shows what torque load the motor can start and stop without loss of a step when started and stopped at a constant step or pulse rate.

The *PULL OUT* curve is the torque available when the motor is slowly accelerated to the operating rate. It is thus the actual dynamic torque produced by the motor.

The difference between the *PULL IN* and *PULL OUT* torque curves is the torque lost due to accelerating the motor rotor inertia.

**The torque/speed characteristic curves are key to selecting the right motor and control drive method for a specific application.**

Note: In order to properly analyze application requirements, the load torque must be defined as being either *Frictional* and/or *Inertial*. (See Handy Formula Section in this engineering guide on pages 12 and 13 for resolving the load torque values. Also, an additional "Application Notes" section is located on pages 10 and 11.)

For information or to place an order in North America: 1 (203) 271-6444 Europe: (44) 1276-691622 Asia: (65) 7474-888

The specifications in this publication are believed to be accurate and reliable. However, it is the responsibility of the product user to determine the suitability of Thomson products for a specific application. While defective products will be replaced without charge if promptly returned, no liability is assumed beyond such replacement.

Use the **PULL IN** curve if the control circuit provides no acceleration and the load is frictional only.

Example: Frictional Torque Load.

Using a torque wrench, a frictional load is measured to be 25 mN•m (3.54 oz-in). It is desired to move this load 67.5° in .06 sec or less.

**Solution:**

1. If a 7.5° motor is used, then the motor would have to take nine steps to move 67.5°.  
A rate of  $v = \frac{9}{.06} = 150$  steps/sec or higher is thus required.
2. Referring to Fig. 6, the maximum **PULL IN** error rate with a torque of 25 mN•m is 185 steps/sec. (It is assumed no acceleration control is provided.)
3. Therefore, a 57L048B motor could be used at 150 steps per second — allowing a safety factor.

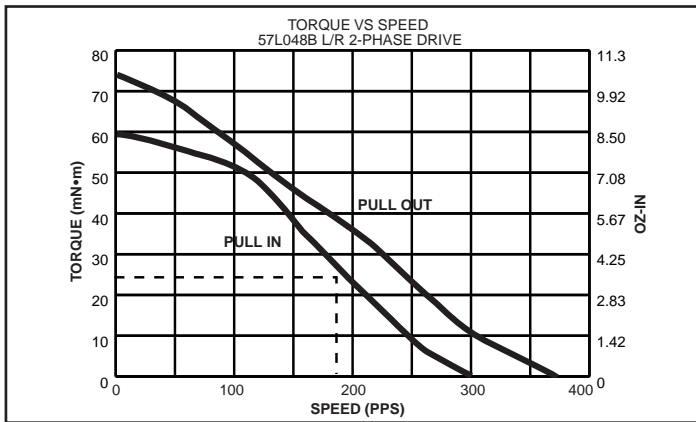

Figure 6: Torque/Speed — Frictional Load.

Use the **PULL OUT** curve, in conjunction with a Torque = Inertia x Acceleration equation ( $T = J\alpha$ ), when the load is inertial and/or acceleration control is provided.

In this equation, acceleration or ramping  $\alpha = \frac{\Delta v}{\Delta t}$  is in radians/sec<sup>2</sup>.

**RAMPING**

Acceleration control or *ramping* is normally accomplished by gating on a voltage controlled oscillator (VCO) and associated charging capacitor. Varying the RC time constant will give different ramping times. A typical VCO acceleration control frequency plot for an incremental movement with equal acceleration and deceleration time would be as shown in Fig. 7.

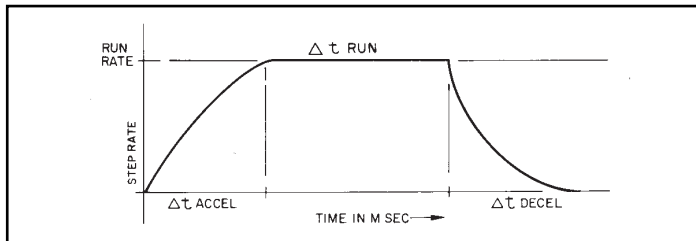

Figure 7: Step Rate/Time.

Acceleration also may be accomplished by changing the timing of the input pulses (frequency). For example, the frequency could start at a 1/4 rate, go to a 1/2 rate, 3/4 rate and finally the running rate.

**A. Applications where:**

**Ramping acceleration or deceleration control time is allowed.**

$$T_J(\text{Torque mN}\cdot\text{m}) = J_T \times \frac{\Delta v}{\Delta t} \times K$$

Where  $J_T$  = Rotor Inertia ( $g\cdot m^2$ ) plus Load Inertia ( $g\cdot m^2$ )

$\Delta v$  = Step rate change

$\Delta t$  = Time allowed for acceleration in seconds

$$K = \frac{2\pi}{\text{steps/rev}} \text{ (converts steps/sec to radians/sec)}$$

$$K = .13 \text{ for } 7.5^\circ \text{ — 48 steps/revolution}$$

$$K = .26 \text{ for } 15^\circ \text{ — 24 steps/revolution}$$

$$K = .314 \text{ for } 18^\circ \text{ — 20 steps/revolution}$$

In order to solve an application problem using acceleration ramping, it is usually necessary to make several estimates according to a procedure similar to the one used to solve the following example:

Example: Frictional Torque Plus Inertial Load with Acceleration Control. An assembly device must move 4 mm in less than 0.5 sec. The motor will drive a lead screw through a gear ratio. The lead screw and gear ratio were selected so that 100 steps of a 7.5° motor = 4 mm. The total Inertial Load (rotor + gear + screw) =  $25 \times 10^{-4} g\cdot m^2$ . The Frictional Load = 15 mN•m

**Solution:**

1. Select a stepper motor **PULL OUT** curve which allows a torque in excess of 15 mN•m at a step rate greater than

$$v = \frac{100 \text{ steps}}{0.5 \text{ sec}} = 200 \text{ steps/sec}$$

Referring to Fig. 8, determine the maximum possible rate (vF) with the frictional load only.

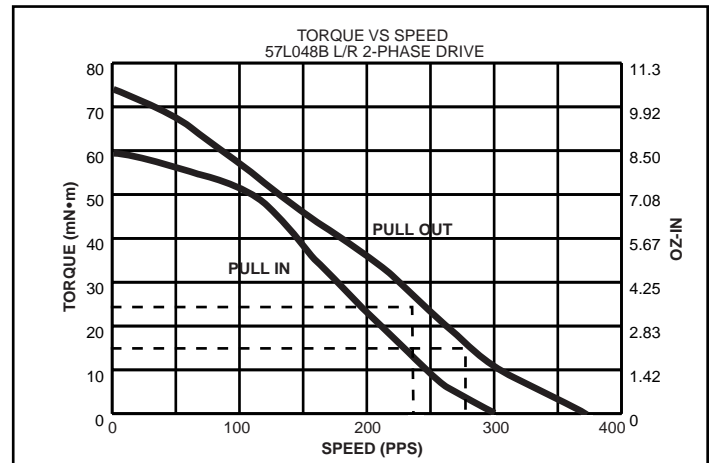

Figure 8: Torque/Speed — Friction Plus Inertia. (Thomson Airpax 57L048B L/R Stepper).

For information or to place an order in North America: 1 (203) 271-6444 Europe: (44) 1276-691622 Asia: (65) 7474-888



The specifications in this publication are believed to be accurate and reliable. However, it is the responsibility of the product user to determine the suitability of Thomson products for a specific application. While defective products will be replaced without charge if promptly returned, no liability is assumed beyond such replacement.

2. Make a first estimate of a working rate (a running rate less than the maximum) and determine the torque available to accelerate the inertia (excess over  $T_F$ ).

$$T_1 - T_F = 23 - 15 = 8 \text{ mN}\cdot\text{m}$$

(torque available for acceleration at 240 steps/sec)

3. Using a 60% safety factor

$$8 \text{ mN}\cdot\text{m} \times .6 = 4.8 \text{ mN}\cdot\text{m},$$

calculate  $\Delta t$  to accelerate. (Refer to Fig. 7).

$$\text{From the } T_J = J_T \times \frac{\Delta v}{\Delta t} \times K \text{ equation,}$$

$$4.8 \text{ mN}\cdot\text{m} = \frac{25 \times 10^{-4} \times 240 \times .13}{\Delta t}$$

Therefore, to accelerate  $\Delta t = .016 \text{ sec}$ .

Note: The same amount of time is allowed to decelerate.

4. The number of steps used to accelerate and decelerate,

$$N_A + N_D = \frac{v}{2} \Delta t \times 2$$

or

$$N_A + N_D = v \Delta t \\ = 240 (.016) = 4 \text{ steps}$$

5. The time to move at the run rate

$$\Delta t_{\text{run}} = N_T - (N_A + N_D) = \frac{100-4}{240} = .4 \text{ sec}$$

Where  $N_T$  = Total move of 100 steps

6. The total time to move is thus

$$\Delta t_{\text{run}} + \Delta t_{\text{accel}} + \Delta t_{\text{decel}} \\ .4 + .016 + .016 = .43 \text{ sec}$$

This is the first estimate. You may make the motor move slower if more safety is desired, or faster if you want to optimize it. At this time, you may wish to consider a faster motor drive combination as will be discussed on page 8.

#### B. Applications where:

**No ramping acceleration or deceleration control time is allowed.**

Even though no acceleration time is provided, the stepper motor can lag a maximum of two steps or 180 electrical degrees. If the motor goes from zero steps/sec to  $v$  steps/sec, the lag time  $\Delta t$  would be

$$\frac{2}{v} \text{ sec}$$

Thus, the torque equation for no acceleration or deceleration is:

$$T (\text{Torque mN}\cdot\text{m}) = J_T \times \frac{v^2}{2} \times K$$

Where:

$$J_T = \text{Rotor Inertia (g}\cdot\text{m}^2) \text{ plus Load Inertia (g}\cdot\text{m}^2)$$

$$v = \text{steps/sec rate}$$

$$K = \frac{2\pi}{\text{step/rev}}$$

("K" values as shown in application A on page 4)

*Example: Friction Plus Inertia – No Acceleration Ramping.*

A tape capstan is to be driven by a stepper motor. The frictional drag torque ( $T_F$ ) is 15.3 mN·m and the inertia of the capstan is  $10 \times 10^{-4} \text{ g}\cdot\text{m}^2$ . The capstan must rotate in  $7.5^\circ$  increments at a rate of 200 steps per second.

#### Solution:

Since a torque greater than 15.3 mN·m at 200 steps per second is needed, consider a 57L048B motor.

The Total Inertia = Motor Rotor Inertia + Load Inertia.

$$J_T = J_R + J_L \\ = (34 \times 10^{-4} + 10 \times 10^{-4}) \text{ g}\cdot\text{m}^2 \\ = 44 \times 10^{-4} \text{ g}\cdot\text{m}^2$$

1. Since there is no acceleration ramping, use the equation:

$$T_J = J_T \times \frac{v^2}{2} \times K \quad (K = .13)$$

$$T_J = 44 \times 10^{-4} \times \frac{200^2}{2} \times .13$$

$$T_J = 11.4 \text{ mN}\cdot\text{m}$$

2. Total Torque =  $T_F + T_J$

$$= 15.3 + 11.4$$

$$= 26.7 \text{ mN}\cdot\text{m}$$

3. Refer to the *PULL OUT* curve Fig. 9, at speed of 200 pulses per second, where the available torque is 35 mN·m. Therefore, the 57L048B motor can be selected with a safety factor.

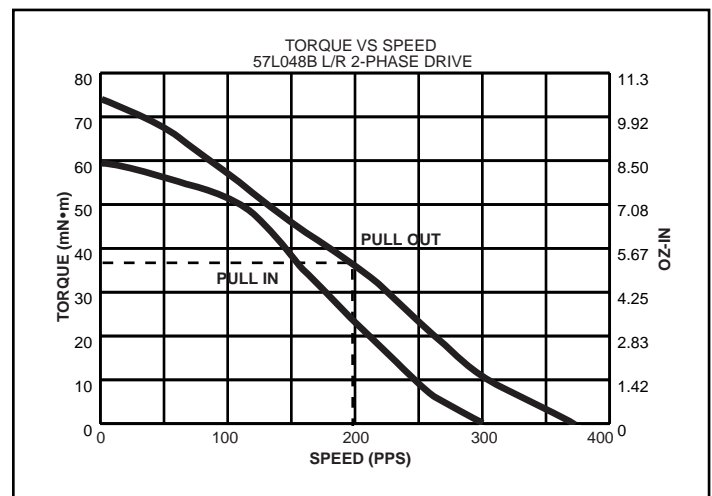

Figure 9: Torque/Speed — Friction Plus Inertia. (Thomson Airpax 57L048B L/R Stepper).

For information or to place an order in North America: 1 (203) 271-6444 Europe: (44) 1276-691622 Asia: (65) 7474-888

The specifications in this publication are believed to be accurate and reliable. However, it is the responsibility of the product user to determine the suitability of Thomson products for a specific application. While defective products will be replaced without charge if promptly returned, no liability is assumed beyond such replacement.

## STEP FUNCTION - SINGLE STEP

When a single step of a motor is made, a typical response is as shown in Figure 10.

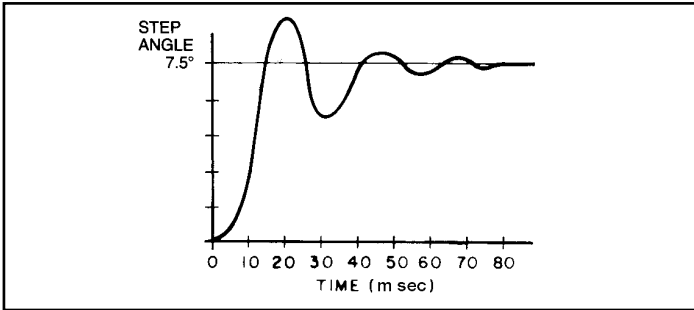

Figure 10: Single Step Response.

The actual response for a given motor is a function of the power input provided by the drive and the load. Increasing the frictional load or adding external damping can thus modify this response, if it is required.

Mechanical dampers (e.g., slip pads or plates), or devices such as a fluid coupled flywheel can be used, but add to system cost and complexity. Electronic damping also can be accomplished. Step sequencing is altered to cause braking of the rotor, thus minimizing overshoot.

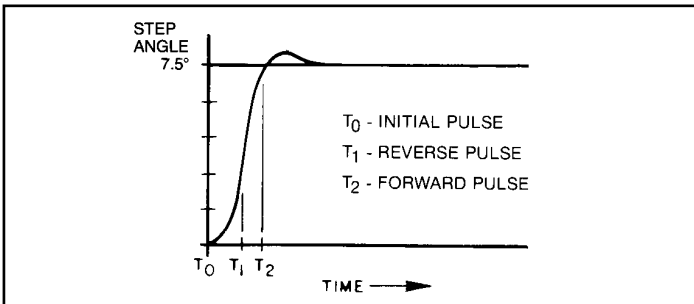

Figure 11: Electronically Damped Response.

## STEP FUNCTION - MULTIPLE STEPPING

Multiple stepping can offer several alternatives. A 7.5° motor moving 12 steps (90°), or a 15° motor moving six steps (90°) to give a 90° output move would have less overshoot, be stiffer, and relatively more accurate than a motor with a 90° step angle. Also, the pulses can be timed to shape the velocity of the motion; slow during start, accelerate to maximum velocity, then decelerate to stop with minimum ringing.

## RESONANCE

If a stepper motor is operated no load over the entire frequency range, one or more natural oscillating resonance points may be detected, either audibly or by vibration sensors. Some applications may be such that operation at these frequencies should be avoided. External damping, added inertia, or a microstepping drive can be used to reduce the effect of resonance. A permanent magnet stepper motor, however, will not exhibit the instability and loss of steps often found in variable reluctance stepper motors, since the PM has a higher rotor inertia and a stronger detent torque.

## DRIVE METHODS

The normal drive method is the 4-step sequence shown in Fig. 2, (page 2); however, the following methods are also possible.

## WAVE DRIVE

Energizing only one winding at a time, as indicated in Fig. 12 is called *Wave Excitation*. It produces the same increment as the 4-step sequence.

Since only one winding is on, the hold and running torque with rated voltage applied will be reduced 30%. Within limits, the voltage can be increased to bring output power back to near rated torque value. The advantage of this type of drive is increased efficiency, while the disadvantage is decreased step accuracy.

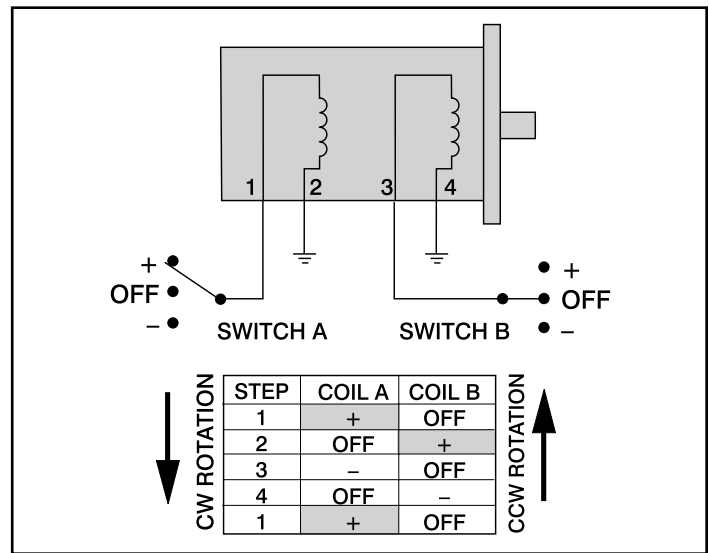

Figure 12: Schematic — Wave Drive Switching Sequence.

## HALF STEP

It is also possible to step the motor in an 8-step sequence to obtain a half step — such as a 3.75° step from a 7.5° motor, as in Fig. 13.

For applications utilizing this, you should be aware that the holding torque will vary for every other step, since only one winding will be energized for a step position; but, on the next step two windings are energized. This gives the effect of a strong step and a weak step. Also, since the winding and flux conditions are not similar for each step when 1/2 stepping, accuracy will not be as good as when full stepping.

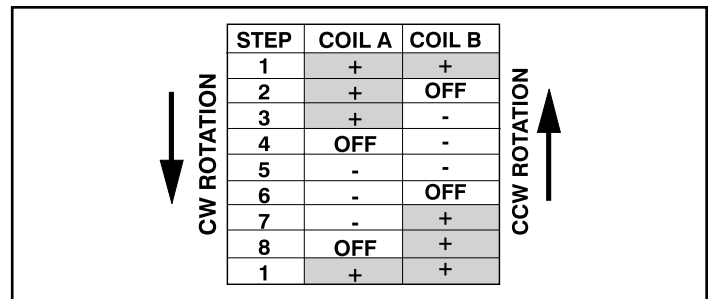

Figure 13: Half Step or 8-Step Switching Sequence.

For information or to place an order in North America: 1 (203) 271-6444 Europe: (44) 1276-691622 Asia: (65) 7474-888



## BIPOLAR AND UNIPOLAR OPERATION

All Thomson Airpax stepper motors are available with either 2-coil *Bipolar*, or 4-coil *Unipolar* windings.

The stator flux with a Bipolar winding is reversed by reversing the current in the winding. It requires a push-pull Bipolar drive as shown in Fig. 14. Care must be taken to design the circuit so that the transistors in series do not short the power supply by coming on at the same time. Properly operated, the Bipolar winding gives the optimum motor performance at low-to-medium step rates.

A Unipolar winding has two coils wound on the same bobbin (one bobbin resides in each stator half) per stator half. Flux is

reversed in each coil bobbin assembly by sequentially grounding ends of each half of the coil winding. The use of a Unipolar winding, sometimes called a *bifilar winding*, allows the drive circuit to be simplified. Not only are half as many power switches required (4 vs. 8), but the timing is not as critical to prevent a current short through two transistors as is possible with a Bipolar drive.

For a Unipolar motor to have the same number of turns per winding as a Bipolar motor, the wire diameter must be decreased and the resistance increased. As a result, Unipolar motors have 30% less torque at low step rates. However, at higher rates the torque outputs are equivalent.

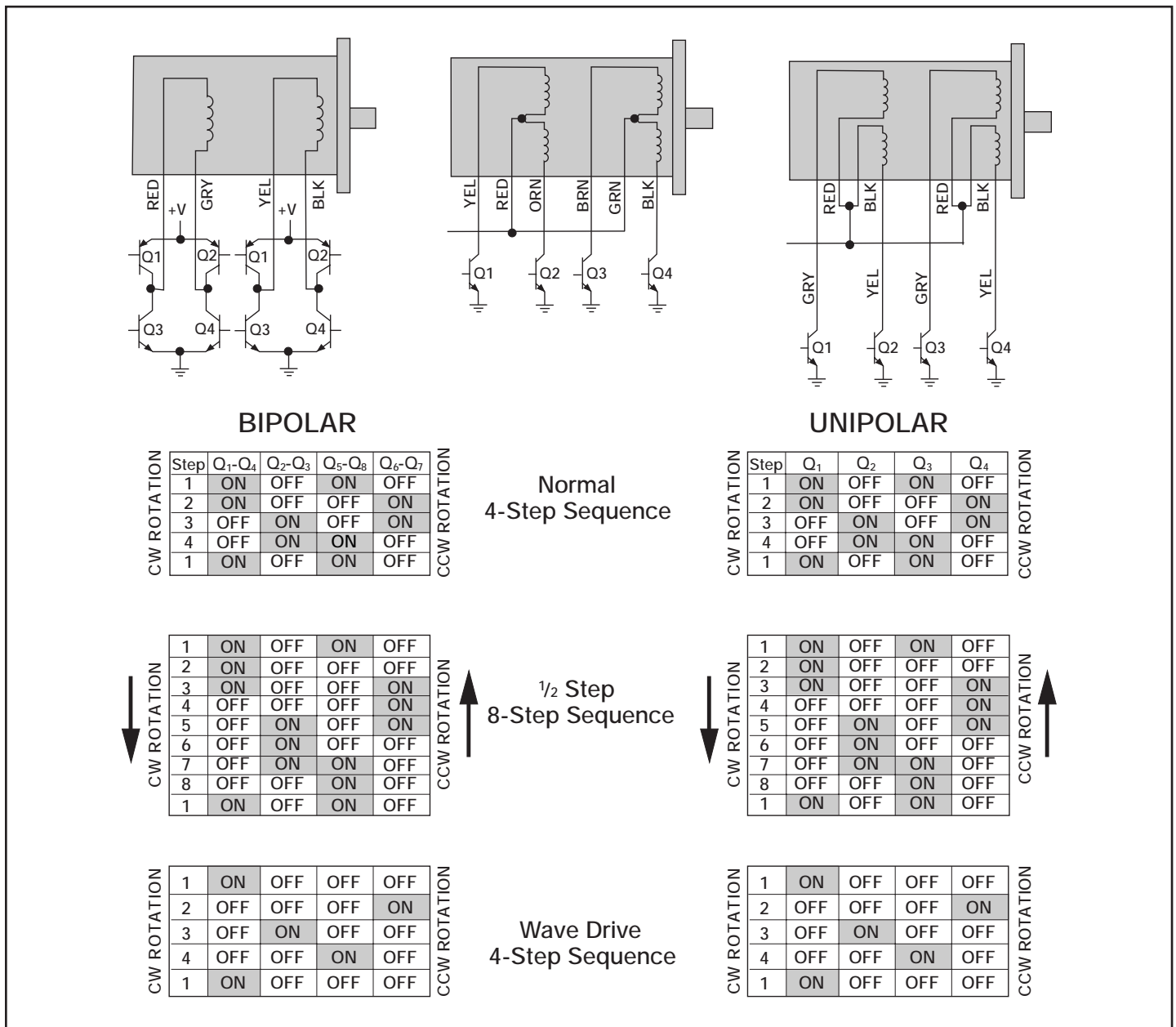

Figure 14: Schematic Bipolar and Unipolar Switching Sequence. Direction of Rotation Viewed from Shaft End.

For information or to place an order in North America: 1 (203) 271-6444 Europe: (44) 1276-691622 Asia: (65) 7474-888

The specifications in this publication are believed to be accurate and reliable. However, it is the responsibility of the product user to determine the suitability of Thomson products for a specific application. While defective products will be replaced without charge if promptly returned, no liability is assumed beyond such replacement.

## HIGHER PERFORMANCE

A motor operated at a fixed rated voltage has a decreasing torque curve as the frequency or step rate increases. This is due to the fact that the rise time of the coil limits the percentage of power actually delivered to the motor. This effect is governed by the inductance to resistance ratio of the circuit (L/R).

Compensation for this effect can be achieved by either increasing the power supply voltage to maintain a constant current as the frequency increases, or by raising the power supply voltage and adding a series resistor in the L/4R drive circuit (See Fig. 15). Note that as the L/R is changed, more total power is used by the system.

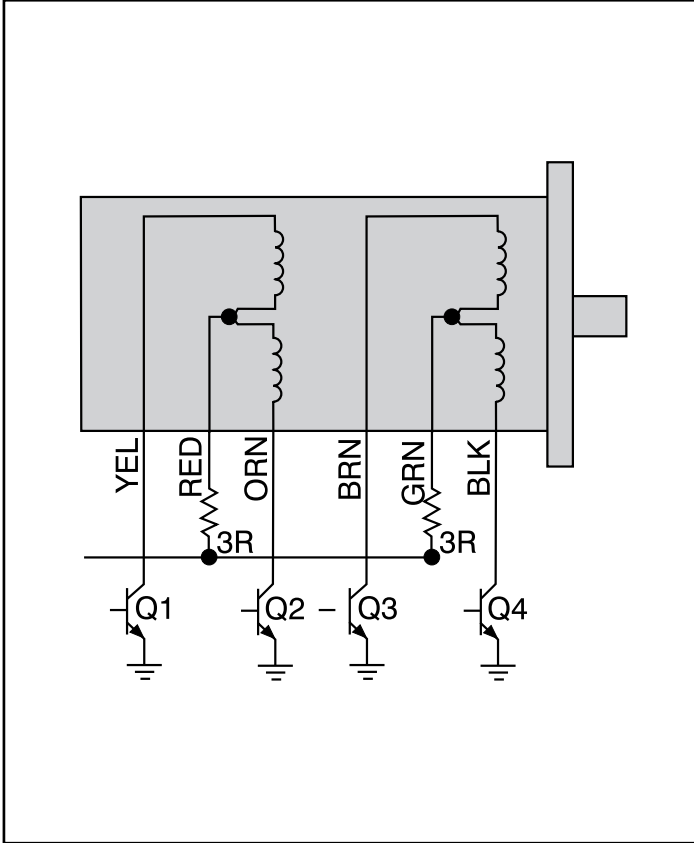

Figure 15: L/4R Drive

The series resistors, R, are selected for the L/R ratio desired. For L/4R they are selected to be three times the motor winding resistance with a wattage rating =  $(\text{current per winding})^2 \times R$ .

The power supply voltage is increased to four times motor rated voltage so as to maintain rated current to the motor. The power supplied will thus be four times that of a L/R drive.

Note, the Unipolar motor which has a higher coil resistance, thus has a better L/R ratio than a Bipolar motor.

To minimize power consumption, various devices such as a bi-level power supply or chopper drive may be used.

## BI-LEVEL DRIVE

The bi-level drive allows the motor at zero steps/sec to hold at a lower than rated voltage. When stepping, it runs at a higher than rated voltage. It is most efficient when operated at a fixed stepping rate. The high voltage may be switched on through the use of a current sensing resistor, or by a circuit (See Fig. 16) which uses the inductively generated turnoff current spikes to control the voltage.

At zero steps/sec the windings are energized with the low voltage. As the windings are switched according to the 4-step sequence, the suppression diodes D<sub>1</sub>, D<sub>2</sub>, D<sub>3</sub> and D<sub>4</sub> are used to turn on the high voltage supply transistors S<sub>1</sub> and S<sub>2</sub>.

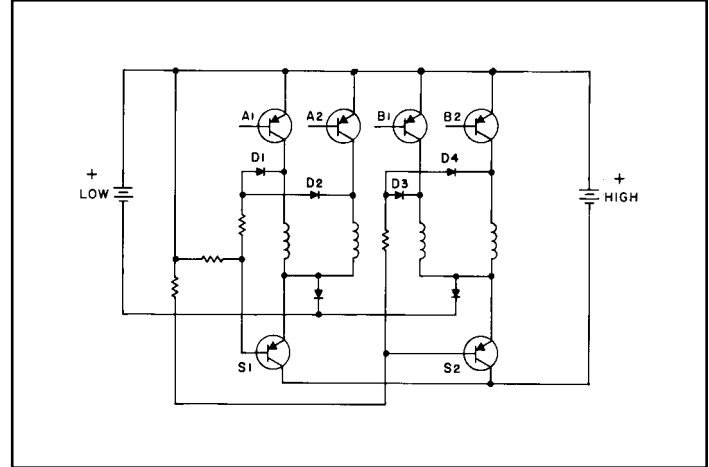

Figure 16: Unipolar Bi-Level Drive.

## CHOPPER DRIVE

A chopper drive maintains an average current level through the use of a current sensor, which turns on a high voltage supply until an upper current value is reached. It then turns off the voltage until a low level limit is sensed, when it turns on again. A chopper is best for fast acceleration and variable frequency applications. It is more efficient than a constant current amplifier regulated supply. The V<sub>+</sub> in the chopper shown in Fig. 17 typically would be five to six times the motor voltage rating.

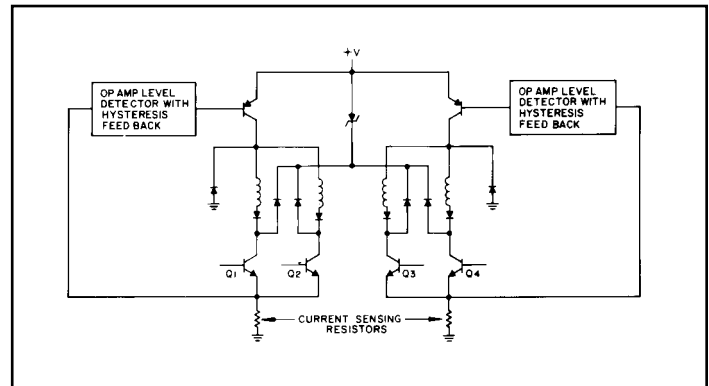

Figure 17: Unipolar Chopper Drive.

For information or to place an order in North America: 1 (203) 271-6444 Europe: (44) 1276-691622 Asia: (65) 7474-888

## VOLTAGE SUPPRESSION

Whenever winding current is turned off, a high voltage inductive spike will be generated, which can damage the drive circuit. The normal method used to suppress these spikes is to put a diode across each winding. This, however, will reduce the torque output of the motor, unless the voltage across the switching transistors is allowed to build up to at least twice the supply voltage. The higher this voltage, the faster the induced field, and current will collapse, and thus the better performance. For this reason, a zener diode or series resistor is usually added as shown in Figure 18.

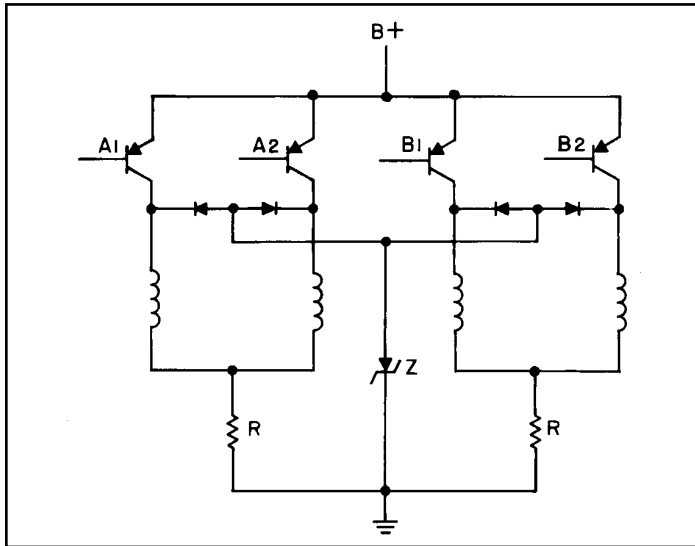

Figure 18: Voltage Suppression Circuit.

## PERFORMANCE LIMITATIONS

Increasing the voltage to a stepper motor at standstill or low stepping rates will produce a proportionally higher torque until the magnetic flux paths within the motor saturate. As the motor nears saturation, it becomes less efficient and thus does not justify the additional power input.

The maximum speed a stepper motor can be driven is limited by hysteresis and eddy current losses. At some rate, the heating effects of these losses limit any further effort to get more speed or torque output by driving the motor harder.

## TORQUE MEASUREMENT

The output torque of a stepper motor and drive can best be measured by using a bridge type strain gage coupled to a magnetic particle brake load. A simple pulley and pull spring scale also can be used, but is difficult to read at low and high step rates.

## MOTOR HEATING AND TEMPERATURE RISE

Operating continuous duty at rated voltage and current will give an approximate 40°C motor winding a temperature rise. If the motor is mounted on a substantial heat sink, however, more power may be put into the windings. If it is desired to push the motor harder, a maximum motor winding temperature of 100°C should be the upper limit. Motor construction can be upgraded to allow for a winding temperature of 120°C (60°C rise).

## SUMMARY OF KEY TORQUE EVALUATIONS

The torque-speed characteristic curves are key to selecting the right motor and the control drive method for a specific application.

Define your application load.

Use the PULL IN curve if the control circuit provides no acceleration and the load is frictional only.

Use the PULL OUT curve, in conjunction with a Torque = Inertia x Acceleration equation ( $T = J\alpha$ ), when the load is inertial and/or acceleration control is provided.

When acceleration ramping control is provided, use the PULL OUT curve and this torque equation:

$$T_J \text{ (Torque mN}\cdot\text{m)} = J_T \times \frac{\Delta V}{\Delta t} \times K$$

When no acceleration ramping control is provided, use the PULL OUT curve and this torque equation:

$$T \text{ (Torque mN}\cdot\text{m)} = J_T \times \frac{v^2}{2} \times K$$

## Motor Selection Guidelines

1. Based on frictional torque and speed, make a first estimate motor selection.
2. Use torque equations and motion plot to evaluate.
3. If necessary, select another motor and/or modify the drive.
4. Secure prototype and test.

Formula for determining temperature rise of a motor (using coil resistance) is:

$$\text{Motor T rise } ^\circ\text{C} = \frac{R_{\text{hot}}}{R_{\text{cold}}} (234.5 + T_{\text{amb cold}}) - (234.5 + T_{\text{amb hot}})$$

For information or to place an order in North America: 1 (203) 271-6444 Europe: (44) 1276-691622 Asia: (65) 7474-888

The specifications in this publication are believed to be accurate and reliable. However, it is the responsibility of the product user to determine the suitability of Thomson products for a specific application. While defective products will be replaced without charge if promptly returned, no liability is assumed beyond such replacement.

Applying a stepper motor can be relatively easy or it can be complex. As a designer gains experience, the versatility and ways to use a stepper motor become more obvious. These application notes should be an aid to you in gaining this experience.

## SELECTION GUIDE

The following elements should be considered in selecting a stepper motor:

1. Frictional torque required in  $\text{mN}\cdot\text{m}$
2. Load inertia in  $\text{g}\cdot\text{m}^2$
3. Move required in degrees
4. Time to complete move in sec
5. Number of steps and step angle in movement
6. Step rate in steps per sec
7. Acceleration - Deceleration time in sec
8. Power available
9. Drive System (Unipolar and/or Bipolar)
10. Size; Weight; Shaft and Mounting considerations

The importance of any of the above elements will, of course, depend on system and budget considerations. Some apply only to positioning type applications. Other considerations should be taken into account for fixed speed or variable speed applications. These might include:

1. RPM required
2. Maximum/Minimum pulse rate required
3. Pulse or frequency source accuracy
4. Allowable velocity variations
5. Resonance

## OPEN LOOP

The features of a stepper motor make it an ideal open loop device for providing precise pulse-to-step movements in a variety of positioning applications from printer paper feeds to small clocks. Most applications are open loop. When operated open loop, always assume worst case values in calculating loads. If you measure average values, allow at least a 20% safety factor. Some applications run open loop with a periodic verification. For example, an electronic typewriter may be character advanced open loop with the line return end position verified by a sensor.

Variable speed or fixed speed applications such as chart drives or reagent pumps take advantage of the fact that variations in torque do not effect the output speed, which is as accurate as the pulse source. For applications such as these you should avoid running at certain frequencies because of resonance.

## CLOSED LOOP

Various devices such as optical encoders or magnetic Hall effect sensors may be used to close the control loop in order to obtain the maximum torque and/or acceleration from a given stepper motor.

In a typical closed loop system, a 2-quadrature track encoder capable of detecting direction could be used to sense that a step has been made before allowing the next pulse to step the motor.

Obviously, the closed loop system will be more complicated and expensive than open loop, but it will have the ability to handle a wide variation in load conditions with optimum acceleration and reliability. Closed loop operation also can be used to stabilize resonance in variable speed applications.

A more detailed analysis of both open and closed loop performance is beyond the scope of this guide; however, it can be obtained by referring to the proceedings from *Incremental Motion Control Systems and Devices, University of Illinois, 1972 to 1998 issues*.

## LOAD COUPLING, GEARS AND PULLEYS, LEAD SCREWS

Other than the added inertia of the coupling, a properly aligned direct coupling will present the load as it is.

Gears, however, will increase or decrease the load by the gear ratio as is shown in the *Handy Formula Section (pages 12-13)*. It is not recommended to gear up, such as to make a  $30^\circ$  movement with a  $15^\circ$  stepper motor. The torque reflected to the motor in this case would be twice the frictional load torque and the inertia would be four times the inertia load.

It would be better to take two motor steps to get the  $30^\circ$  movement, or if the motor load were high, take four motor steps of  $7.5^\circ$  and gear down 2:1 speed torque curve permitting. In this instance, the motor would see only 1/2 the frictional load and 1/4 the inertial load.

Equations using lead screws also are given in the *Handy Formula Section*. Note how the load to the motor is reduced when the lead of the screw is small.

*The following examples show how three typical systems were designed.*

### 1. FIXED SPEED APPLICATION

A stepper motor being run at a fixed speed is in reality a synchronous motor running on square waves.

Typical applications running at fixed frequencies are timing devices, recorders, meters and clocks.

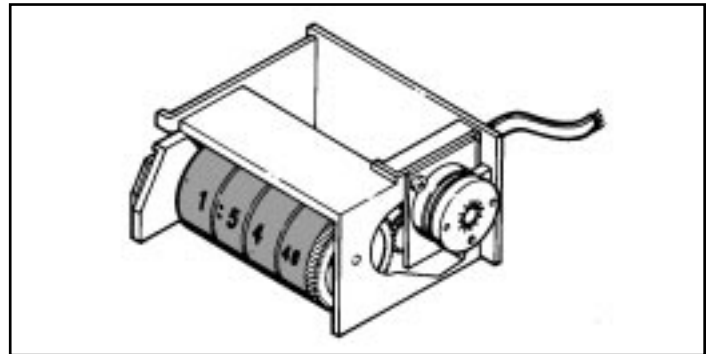

One such system, a DC operated clock, uses a small stepper motor and drive with signal pulses supplied by a 240 Hz crystal oscillator module. The 240 Hz signal generates the equivalent of 60 Hz 2-phase operation. When operated at this pulse rate, a  $15^\circ$  stepper rotates at 600 RPM and will be as accurate as the crystal rate.

For information or to place an order in North America: 1 (203) 271-6444 Europe: (44) 1276-691622 Asia: (65) 7474-888

# Application Notes

## 2. POSITIONING TYPE APPLICATION

A computer peripheral type serial character printer is a typical positioning application. The stepper motor is used to advance the paper for line feed.

The printer prints either six or eight lines per inch.

A 4.5:1 gear ratio is used between the paper roller and the motor. A 7.5° stepper motor taking eight steps per incremental movement will advance the paper at six lines per inch. A simple control logic change makes the motor take six steps per movement giving eight lines per inch.

The reflected frictional load to the motor is 22% of the frictional load of the roller and paper and only 5% of the inertial load because of the gear ratio.

Since the motor always takes at least six pulses to move a line, the timing of the pulses is spaced or ramped so as to accelerate and decelerate the motor in the fastest time with minimum ringing.

In order to get the maximum line feed rate, the motor is driven by a bi-level supply which puts five times rated voltage on the motor when stepping and drops down to 25% rated voltage when not being stepped. This allows maximum input power during stepping and minimum dissipation during standstill.

Additionally, the accuracy of the spacing between lines is optimum, since the motor is stepped in multiples of four or two.

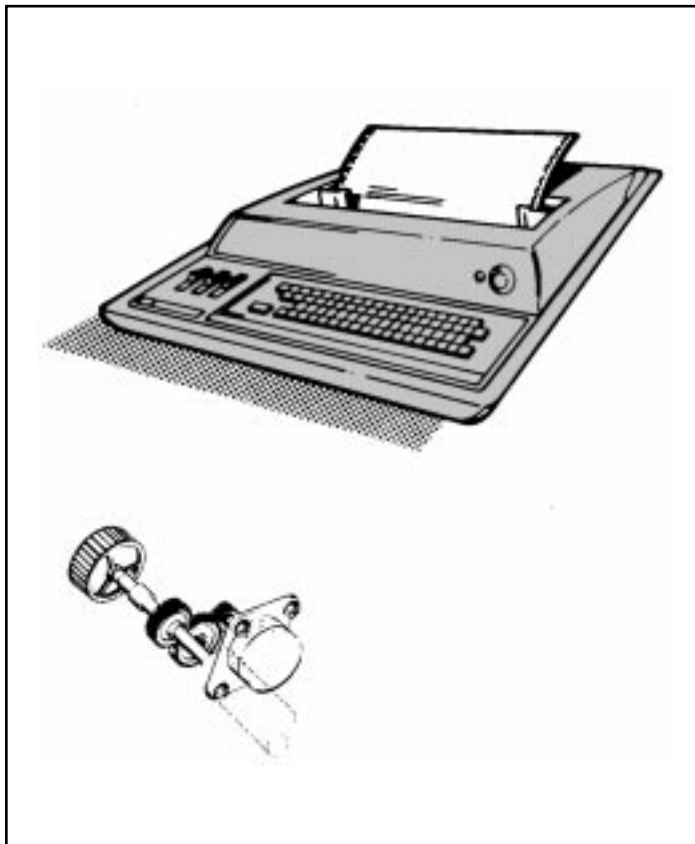

## 3. VARIABLE SPEED APPLICATION

Many variable speed applications use DC motors with the speed of the motor being controlled by velocity feedback devices. Since problems of life, noise and complexity of feedback servo make the use of a DC motor unsatisfactory, it is more advantageous to use stepper motors in applications such as a reagent pump.

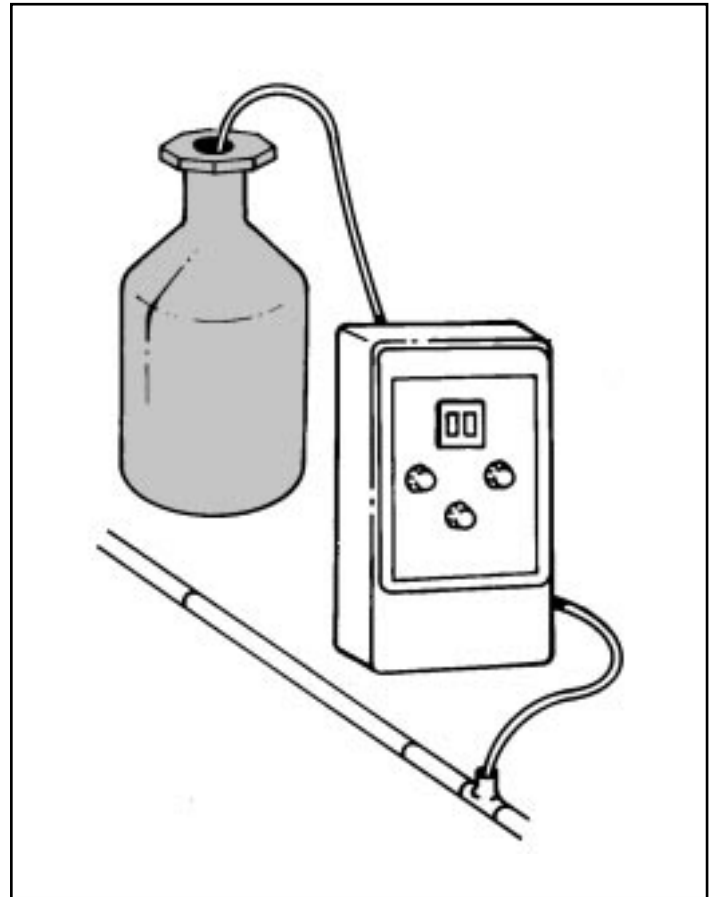

Reagent pumps are used to dispense various solutions at preselected rates. A crystal oscillator is used as the base frequency. Sub-multiples of this frequency are obtained by dividing the base frequency to get the desired feed rates.

A 4:1 ratio pulley and belt couple the 7.5° stepper motor to the pump. The stepper motor was selected on the basis of the maximum running rate torque required with a 50% safety factor. Since the feed rates are fixed by the crystal, torque load variations within the range have no effect on the rate the fluid is dispensed.

The relative low shaft speed of the motor and the absence of brushes provide the long motor life required of the pump. Also, the stepper motor has the ability to be pulsed from very low rates to very high rates, thus giving the pump a possible flow rate range of 1000:1. A practical open loop DC system speed range is only about 10:1.

For information or to place an order in North America: 1 (203) 271-6444 Europe: (44) 1276-691622 Asia: (65) 7474-888

The specifications in this publication are believed to be accurate and reliable. However, it is the responsibility of the product user to determine the suitability of Thomson products for a specific application. While defective products will be replaced without charge if promptly returned, no liability is assumed beyond such replacement.

# Handy Formulas

Primary units in this guide are metric (SI – the International System of units):

- Length - m - (meter)
- Mass - g - (gram)
- Force - mN - (millinewton)
- Torque - mN•m - (millinewton meter)
- Inertia - g•m<sup>2</sup> - (gram meter<sup>2</sup>)

In this system, mass is always in kilograms or grams. Force, or weight, is always in newtons or millinewtons.

$$\text{Force (or weight)} = \text{Mass} \times \text{Acceleration}$$

$$F = ma$$

when  $a = 9.81 \text{ m/sec}^2$  (acceleration due to gravity), then F would be the weight in newtons.

## How to measure Mass or Force.

A spring scale reading of 1 kg means that you are measuring a mass of 1 kg.

A spring scale reading of 2.2 lb also is measuring a mass of 1 kg.

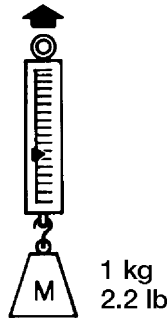

If you use that same spring scale to measure a force, the 1 kg reading must be multiplied by 9.8 to give a force of 9.8 newtons.

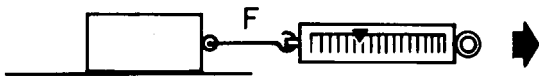

The reading of 2.2 lb is a force and is equal to 9.8 newtons.

If the same scale is used to measure torque ( $T = FR$ ) at a one meter radius, the reading of

$$1 \text{ kilogram} \times 1 \text{ meter} = 1 \text{ kgm}$$

must be multiplied by 9.8 to give a torque of 9.8 newton meters (N•m).

	Given Unit		Units Used in this Manual (Metric SI)
Length	1 inch =	2.54 cm =	$2.54 \times 10^{-2} \text{m}$
Force	1 oz =	=	278 mN
	1 lb =	4.45 N =	4,450 mN
	1 g•cm =	=	9.8 mN
Mass	1 lb =	=	454g
	1oz =	=	28.4g
	1kg =	=	1,000g
	1 slug =	14.6 kg =	14,600g
Inertia	1 g•cm <sup>2</sup> =	=	$10^{-4} \text{g} \cdot \text{m}^2$
	1 oz-in-sec <sup>2</sup> =	=	$7.06 \text{g} \cdot \text{m}^2$
	1 slug ft <sup>2</sup> =	=	$.29 \text{g} \cdot \text{m}^2$
Torque	1 oz-in =	72.01 g•cm =	7.06 mN•m
	1 lb-ft =	=	$1.356 \times \text{N} \cdot \text{m}$
	1 g•cm =	=	$9.8 \times 10^{-2} \text{mN} \cdot \text{m}$
		10.2 g•cm =	1 mN•m
		141.6 oz-in =	1 N•m

$$1. \text{ Torque (mN} \cdot \text{m)} = \text{Force (mN)} \times \text{Radius (m)}$$

$$\text{Torque} = FR$$

$$2. \text{ Torque required to accelerate inertial load}$$

$$T \text{ (mN} \cdot \text{m)} = J \alpha$$

$$J = \text{Inertia in } \text{g} \cdot \text{m}^2$$

$$\alpha = \text{Acceleration in radians/sec}^2$$

EXAMPLE:

If a rotor inertia plus load inertia =  $J = 2 \times 10^{-3} \text{g} \cdot \text{m}^2$ , and the motor is to be accelerated at 6,000 radians per sec, what torque is required?

$$T = J\alpha = 2 \times 10^{-3} \times 6000$$

$$T = 12 \text{ mN} \cdot \text{m}$$

For stepper motors,  $\alpha$  can be converted to radians/sec<sup>2</sup> from steps/sec<sup>2</sup>.

$$\alpha \text{ (radians/sec)} = \frac{\Delta v \text{ (steps/sec)}}{\Delta t \text{ (accel. time)}} \times \frac{2\pi}{\text{steps/rev}}$$

$$\text{TORQUE} = J \frac{\Delta v}{\Delta t} \times \frac{2\pi}{\text{steps/rev}}$$

EXAMPLE:

For a 48-step per revolution motor accelerating from zero to steps/sec running rate  $v$  in  $\Delta t$  seconds.

$$\text{TORQUE} = J \frac{v}{\Delta t} \times \frac{\pi}{24}$$

For information or to place an order in North America: 1 (203) 271-6444 Europe: (44) 1276-691622 Asia: (65) 7474-888

If no *acceleration time* is provided, then a maximum 2-step lag can occur.

$$\Delta t \text{ (sec)} = \frac{2 \text{ (steps)}}{v \text{ (steps/sec)}} \text{ giving the following equation.}$$

$$\text{TORQUE} = J \frac{V^2}{2} \times \frac{2 \pi}{\text{steps/rev}}$$

### 3. Moment of Inertia

#### Disc or shaft

M = Mass in grams

R = Radius in meters

$$J \text{ (g}\cdot\text{m}^2) = \frac{MR^2}{2}$$

#### Cylinder

$$J \text{ (g}\cdot\text{m}^2) = \frac{M^2}{2} (R_1^2 + R_2^2)$$

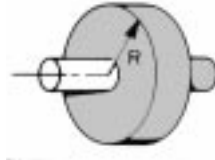

### 4. Reflected loads when using gears or pulleys

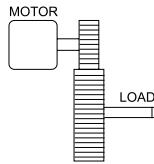

$$\text{Torque required of motor} = \frac{\text{Load Torque}}{GR}$$

$$\text{gear or pulley ratio GR} = \frac{\text{motor shaft revolutions}}{\text{load shaft revolutions}}$$

$$\text{Inertia reflected to motor} = \frac{\text{Load inertia}}{(GR)^2}$$

### 5. Equivalent Inertial Load

For a pulley and weight or a rack and pinion

$$J \text{ eqv. (g}\cdot\text{m}^2) = MR^2$$

M = Mass of load in grams

R = Radius of pulley in meters

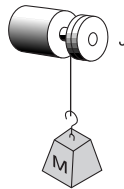

### 6. Total Load

Note: Be sure to include all load components.

$$J_T = \text{Rotor Inertia} + \text{all J Loads}$$

$$T_F = \text{Frictional and Forces}$$

Note: In the pulley example above, the total load would be:

$$J_T = J \text{ rotor} + J \text{ pulley} + J \text{ eqv.}$$

$$T_F = T \text{ frictional} + \text{Load Weight} \times \text{Radius}$$

$$\text{Total T} = J_T \alpha + T_F$$

The load weight = mass x 9.8 millinewtons.

### 7. Axial Force of Lead Screw

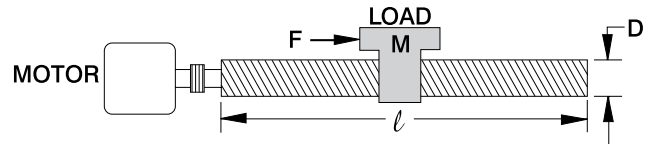

$$F = \frac{2 \pi \times T}{L} \times \text{eff.}$$

F (mN) when T = Torque in mN•m

L = Lead of screw in meters

F (oz) when T = Torque in oz-in

L = Lead of screw in inches

efficiency = from .9 for ballnut to .3 for Acme

Inertia of lead screw load

$$J = J \text{ rotor} + J \text{ steel screw} + J \text{ reflected}$$

$$J \text{ steel screw} = D^4 \times l \times \frac{\pi}{32} \times \text{Density}$$

$$\text{Density for steel} = 7.83 \times 10^6 \text{ g/m}^3$$

then:

$$J \text{ (g}\cdot\text{m}^2) = D^4 \times l \times 7.7 \times 10^5$$

The reflected inertia of the load is:

$$J \text{ reflected (g}\cdot\text{m}^2) = M \text{ (load)} L^2 \times .025$$

Total Torque Load from lead screw (T) in mN•m

$$T = (J \text{ rotor} + J \text{ screw} + J \text{ reflected}) \alpha + T \text{ friction}$$

### 8. Motor watts output

$$\text{Watts out} = \text{Torque output} \times \text{speed in radians/sec}$$

$$1 \text{ watt} = 1 \text{ Nm/sec}$$

For a given output Torque (mN•m) and converting v (steps/sec) to radians/sec

$$\text{Watts out} = \text{Torque (mN}\cdot\text{m)} \times v \frac{(\text{motor step angle})}{57.3} \times 10^{-3}$$

If the speed is in RPM then:

$$\text{Watts out} = 1.05 \times 10^{-4} \times \text{torque (mN}\cdot\text{m)} \times \text{RPM}$$

### 9. Steps/sec to RPM

$$\text{RPM} = \frac{v \text{ (steps/sec)} \times 60}{\text{motor steps/rev}}$$

For information or to place an order in North America: 1 (203) 271-6444 Europe: (44) 1276-691622 Asia: (65) 7474-888

The specifications in this publication are believed to be accurate and reliable. However, it is the responsibility of the product user to determine the suitability of Thomson products for a specific application. While defective products will be replaced without charge if promptly returned, no liability is assumed beyond such replacement.

## Permanent Magnet Stepper And Geared Motors

Thomson Airpax Mechatronics manufactures permanent magnet (PM) stepper motors. They have a stator construction that consists of bobbin wound coils surrounded by a "claw tooth" pole configuration and a rotor assembly that includes a multi-pole ring magnet.

- Standard Industry configuration for drop-in replacement
- Motor sizes from  $\phi 15\text{mm}$  to  $\phi 60\text{mm}$ , with step angles ranging from  $3.6^\circ$  to  $18^\circ$
- Simple mechanical construction with proven design characteristics
- Self-lubricating sintered bronze bearings
- Ideal for high volume production

Permanent magnet motors also are available with gear reductions, which provide the following advantages:

- Higher motor output torque (  $35.3 \text{ mN}\cdot\text{m}/5 \text{ oz}\cdot\text{in}$  to  $13.56 \text{ mN}\cdot\text{m}/10 \text{ lb}\cdot\text{ft}$ ) with compact gear train packages
- Gearboxes adaptable to 26mm, 35mm, 42mm & 57mm frame size motors
- Available in wide range of gear and pinion materials for optimum cost and performance
- Standard Industry configuration for drop-in replacement
- Reduces impact of load inertia
- Full utilization of the maximum motor power

Thomson Airpax Mechatronics motor products are ideally suited for applications such as:

- Computer Peripherals
- Office Automation
- HVAC
- Medical
- Instrumentation
- Communications

*Call or E-Mail and discuss your application with an expert*

North America: 1 (203) 271-6444  
motorinfo@snet.net

Europe: (44) 1276-691622  
info@tammail.com

Asia: (65) 7474-888  
airpax@tamsales.com.sg





# Application Chart

The applications for Permanent Magnet, Hybrid, Value Added (Gear-Train & DLA) Stepper Motors and Brushless DC Motors are virtually

unlimited. Listed here are some typical motion control applications where reliability, repeatability, and controllability are most important.

	PM Stepper & Hybrid Stepper	Geared Stepper	Digital Linear Actuator (DLA)	Brushless DC Motor (BLDC)
<b>COMPUTER PERIPHERAL</b>				
Disk Drive	■			■
Ink Jet/Laser Printers	■			■
Thermal/Dot Matrix Printers	■			
Plotter	■		■	
Page/Document Scanner	■	■		
<b>OFFICE AUTOMATION</b>				
Copy Machine	■			■
Facsimile Machine	■			
Typewriter/Printer	■		■	
Identification/Smart Card	■			
Bar-Code Machine	■	■		■
Mail Handling System	■			■
<b>HVAC</b>				
Valves	■	■	■	
Dampers	■	■	■	■
Thermostats	■			
<b>GAMING</b>				
Slot Machine	■			
<b>MEDICAL</b>				
Peristaltic Pump	■	■		
Fluid Metering	■	■		■
Pipette	■		■	
Blood Analyzer	■	■	■	■
<b>INSTRUMENTATION</b>				
Chart Recorder	■	■		
Camera, Optical Scope	■	■	■	
Buoy		■		
Security Camera	■	■	■	■
Laser Alignment		■		■
Robotics	■	■	■	■
Telecommunications	■	■	■	
Satellite Antenna	■	■		■

For information or to place an order in North America: 1 (203) 271-6444 Europe: (44) 1276-691622 Asia: (65) 7474-888

The specifications in this publication are believed to be accurate and reliable. However, it is the responsibility of the product user to determine the suitability of Thomson products for a specific application. While defective products will be replaced without charge if promptly returned, no liability is assumed beyond such replacement.



# Stepper Motor Quick Reference Chart

Permanent Magnet Stepper Motor							
SERIES	Holding Torque (Min.) (mN•m/oz-in)	Step Angle (Degrees)	Steps/Rev	DC Operating Voltage	Resistance/Windings $\Omega$ Unipolar		Page for full Specs
					5 Vdc	12 Vdc	
15M020D	3.33/.55	18	20	5	40	–	17
26M048B	7.0/0.99	7.5	48	5 or 12	20	110	18
26M024B	5.5/0.78	15	24	5 or 12	20	110	19
35M048B	17.4/2.6	7.5	48	5 or 12	12.5	72	20
35M024B	16.2/.2.3	15	24	5 or 12	12.5	72	20
35M020B	13.4/1.9	18	20	5 or 12	12.5	72	20
35L048B	25.0/3.5	7.5	24	5 or 12	11.0	64	21
35L024B	21.1/3.0	15	24	5 or 12	11.0	64	21
35L020B	17.7/2.5	18	20	5 or 12	11.0	64	21
42M048C	73.4/10.4	7.5	48	5 or 12	9.1	52.4	22
42M100B	33/4.8	3.6	100	5 or 12	12.5	75	23
57L048B	113/16.0	7.5	48	5 or 12	6.3	36	24
57M024B	55/7.8	15	24	5 or 12	6.3	36	24
57M048B	74/10.5	7.5	48	5 or 12	6.3	36	24
60L048B	198/28	7.5	48	5 or 12	4.6	26.0	25
60L024B	141/20	15	24	5 or 12	4.6	26.0	25
4SQ	65/9.2	1.8	200	12	–	74.0	26
4SHG (46mm)	388/55	1.8	200	6 to 12	7 $\Omega$ @ 6 Vdc	104 $\Omega$ @ 24 Vdc	27
4SHG (56mm)	600/85	1.8	200	6 to 12	4.7 $\Omega$ @ 6 Vdc	79 $\Omega$ @ 24 Vdc	27

Permanent Magnet Stepper Motor with Gear Trains							
SERIES	Gear Train Rating		Shape of Gear Box	DC Operating Voltage	Resistance/Windings $\Omega$ Unipolar		Page for full Specs
	(Running) (mN•m/oz-in)	(Static) (mN•m/oz-in)			5 Vdc	12Vdc	
26M048B-V	70.6/10	141.2/20	Football	5 or 12	20.0	110.0	28
35M048B-X	35.3/5	141.2/20	Pear	5 or 12	12.5	72.0	29
42M048C-R	706/100	1.06 N•m/150	Round	5 or 12	9.1	52.4	30
42M048C-Z	1.4 N•m/200	2.12 N•m/300	Pear	5 or 12	9.1	52.4	31

Digital Linear Actuator							
SERIES	Linear Travel Per Step mm/in	Maximum Force	Min. Holding Force (Unenergized)	DC Operating Voltage	Resistance/Windings $\Omega$ Unipolar		Page for full Specs
					5 Vdc	12Vdc	
K & L 92100	.25/.001 .05/.002 .10/.004	12.5 N/45 oz	16.68 N/60 oz @ .025 mm/.001"	5 or 12	15.0	84.0	34-35
K & L 92200	.25/.001 .05/.002 .76/.003	20.9 N/75 oz	11.1 N/40 oz @ .025 mm/.001"	5 or 12	10.0	58.0	36-37
L92400	.025/.001 .05/.002	88 N/20 lb	88 N/20 lb @ .025 mm/.001"	5 or 12	4.3	25.0	38-39

The L/R torque/speed curves are intended as guides for motor selection and are considered to be typical. Improved performance can be achieved through the use of various drive methods (several approaches are described on pages 8 and 9 of this engineering guide) or by using high-energy magnet materials. For more specific recommendations to cover your application — contact one of our experienced sales engineers.

Note: Inductance is measured using an LRC bridge with  $L_S$  scale and internal 1 KC oscillator..

All above data as well as data shown on proceeding pages are specified at room temperature, with operating voltage at the motor leads.

For information or to place an order in North America: 1 (203) 271-6444 Europe: (44) 1276-691622 Asia: (65) 7474-888

# Series 15M020D Stepper Motors



## Dimensions: mm/inches

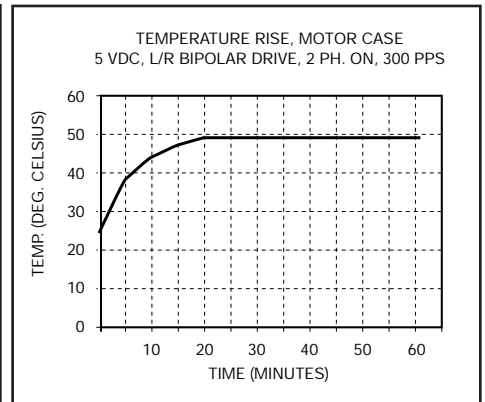
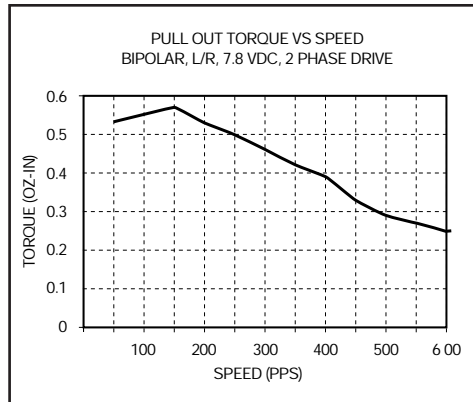
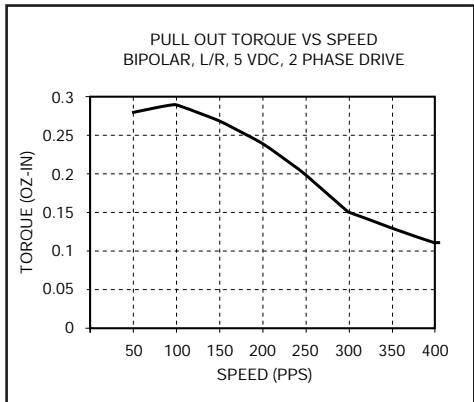
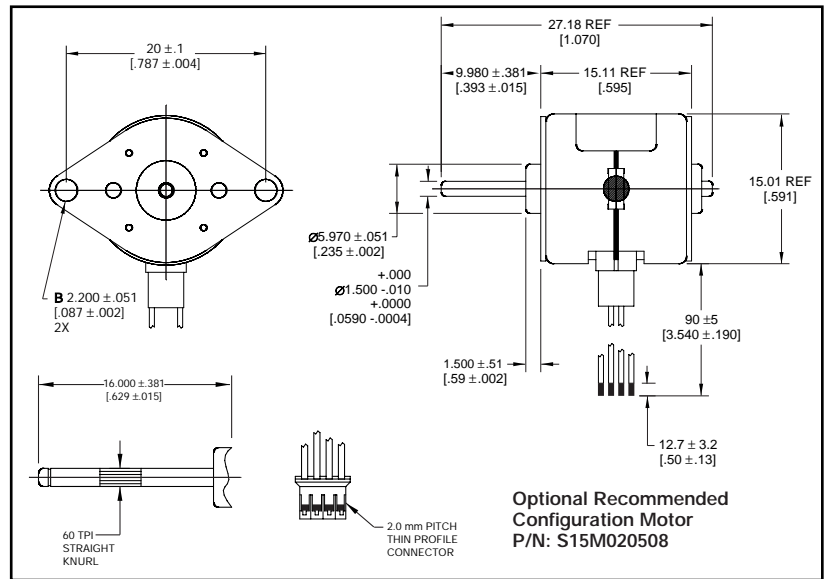

## Specifications

Part Number	15M020D1B
DC Operating Voltage	5
Res. per Winding $\Omega$	40 $\pm$ 10%
Ind. per Winding mH	14 $\pm$ 20%
Holding Torque mN•m/oz-in <sup>†</sup>	3.88/55
Detent Torque mN•m/oz-in	1.62/.23
Step Angle	18°
Step Angle Tolerance <sup>†</sup>	$\pm$ 1.5°
Steps per Rev.	20
Max Operating Temp.	100°C
Ambient Temp Range	
Operating	-20°C to 70°C
Storage	-40°C to 85°C
Bearing Type	Bronze sleeve
Insulation Res. at 500Vdc	100 megohms
Dielectric Withstanding Voltage	400 $\pm$ 50 VRMS 60 Hz for 2 seconds
Weight g/oz	14 g/0.5 oz
Lead Wires	28 AWG, UL style 1429

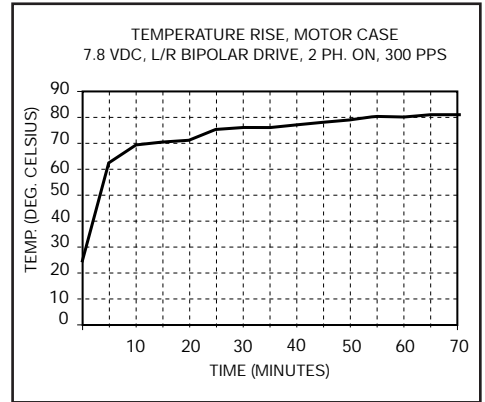

<sup>†</sup> Measured with 2 phases energized.

For information or to place an order in North America: 1 (203) 271-6444 Europe: (44) 1276-691622 Asia: (65) 7474-888

The specifications in this publication are believed to be accurate and reliable. However, it is the responsibility of the product user to determine the suitability of Thomson products for a specific application. While defective products will be replaced without charge if promptly returned, no liability is assumed beyond such replacement.



# Series 26M048B Stepper Motors



Dimensions: mm/inches

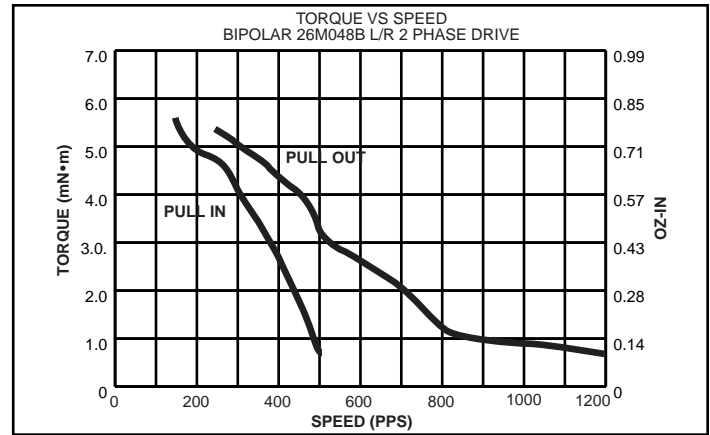
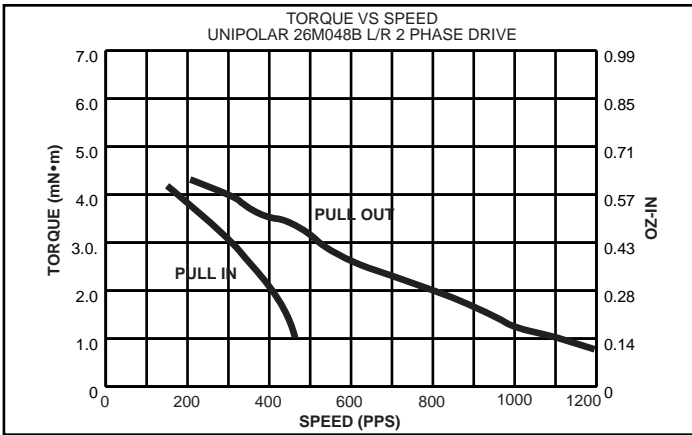
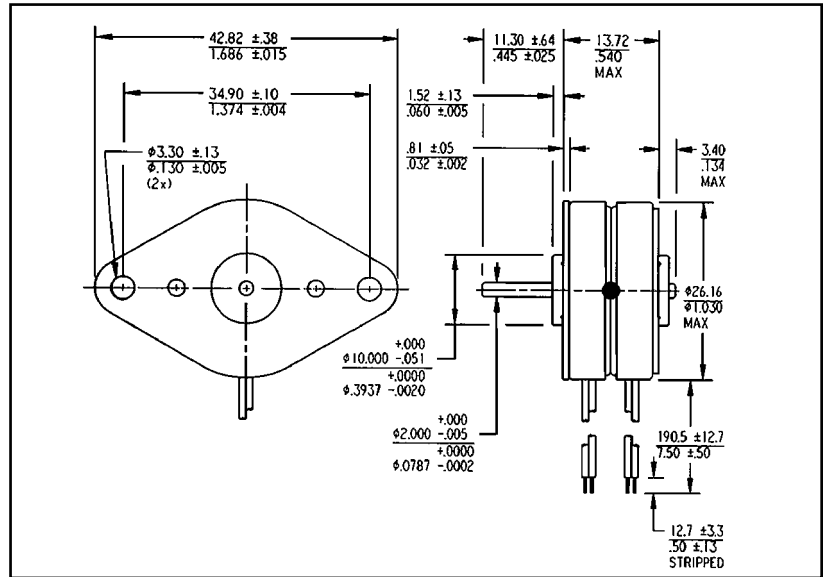

## Specifications

NOTE: Refer to page 7 for switching sequence

Part Number	Unipolar		Bipolar	
	26M048B1U	26M048B2U	26M048B1B	26M048B2B
DC Operating Voltage	5	12	5	12
Res. per Winding $\Omega$	19.6	110	19.8	108
Ind. per Winding mH	5.3	36.5	13.0	60.7
Holding Torque $mN\cdot m/oz\cdot in^{\dagger}$	9.2/1.3		10.6/1.5	
Rotor Moment of Inertia $g\cdot m^2$	1.1 x 10 <sup>-4</sup>			
Detent Torque $mN\cdot m/oz\cdot in$	0.85/0.12			
Step Angle	7.5°			
Step Angle Tolerance <sup>†</sup>	± 5°			
Steps per Rev.	48			
Max Operating Temp.	100°C			
Ambient Temp Range				
Operating	-20°C to 70°C			
Storage	-40°C to 85°C			
Bearing Type	Bronze sleeve			
Insulation Res. at 500Vdc	100 megohms			
Dielectric Withstanding Voltage	650 ± 50 VRMS 60 Hz for 1 to 2 seconds			
Weight g/oz	28 g/1 oz			
Lead Wires	28 AWG			

<sup>†</sup> Measured with 2 phases energized.

For information or to place an order in North America: 1 (203) 271-6444 Europe: (44) 1276-691622 Asia: (65) 7474-888

# Series 26M024B Stepper Motors



Dimensions: mm/inches

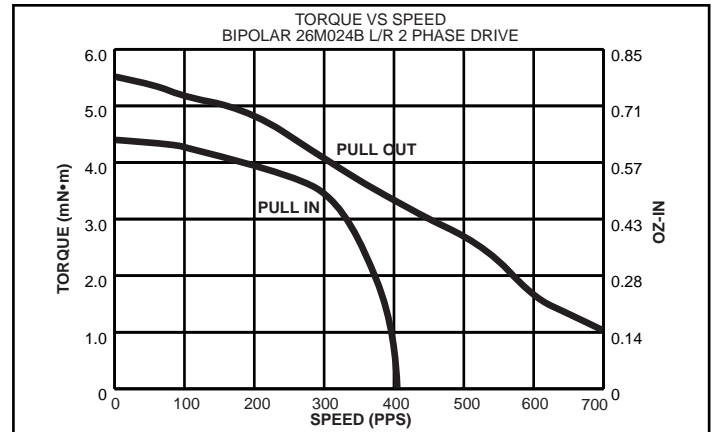
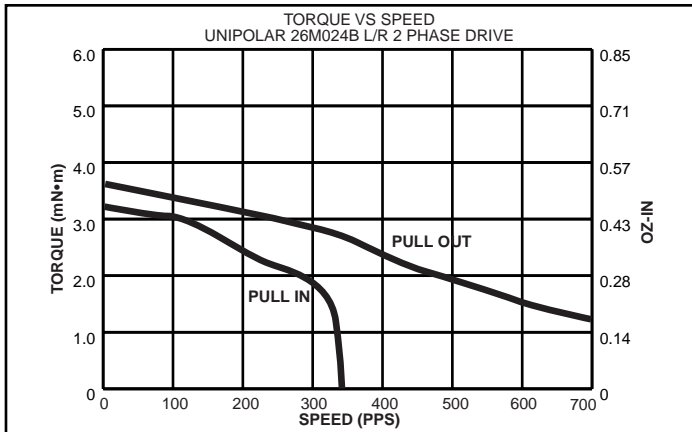
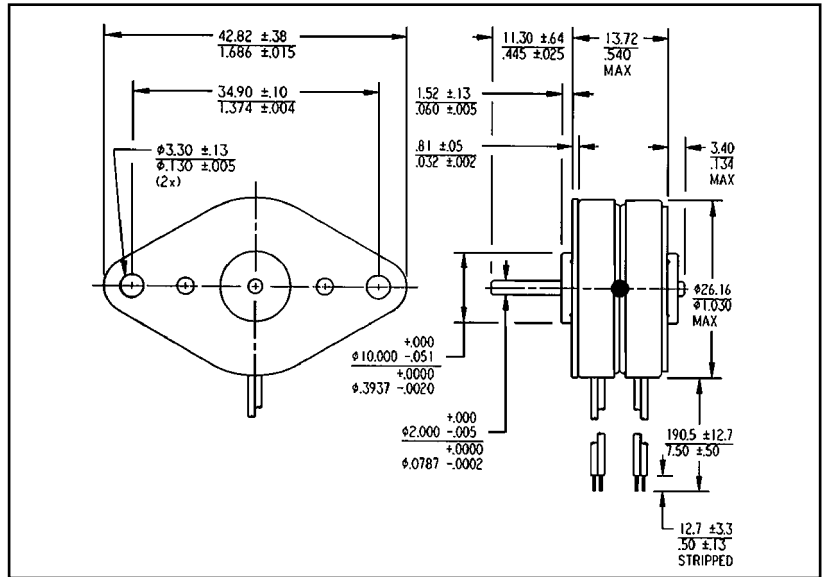

## Specifications

NOTE: Refer to page 7 for switching sequence

Part Number	Unipolar		Bipolar	
	26M024B1U	26M024B2U	26M024B1B	26M024B2B
DC Operating Voltage	5	12	5	12
Res. per Winding Ω	20.4	118	19.6	113
Ind. per Winding mH	6.4	33.8	13.8	72.9
Holding Torque mN·m/oz-in†	4.9/0.7		7.1/1.0	
Rotor Moment of Inertia g·m <sup>2</sup>	1.1 x 10 <sup>-4</sup>			
Detent Torque mN·m/oz-in	1.06/0.15			
Step Angle	15°			
Step Angle Tolerance†	±1°			
Steps per Rev.	24			
Max Operating Temp.	100°C			
Ambient Temp Range				
Operating	-20°C to 70°C			
Storage	-40°C to 85°C			
Bearing Type	Bronze sleeve			
Insulation Res. at 500Vdc	100 megohms			
Dielectric Withstanding Voltage	650 ±50 VRMS 60 Hz for 1 to 2 seconds			
Weight g/oz	28 g/1 oz			
Lead Wires	28 AWG			

† Measured with 2 phases energized.

For information or to place an order in North America: 1 (203) 271-6444 Europe: (44) 1276-691622 Asia: (65) 7474-888

The specifications in this publication are believed to be accurate and reliable. However, it is the responsibility of the product user to determine the suitability of Thomson products for a specific application. While defective products will be replaced without charge if promptly returned, no liability is assumed beyond such replacement.



# Series 35M048B, 35M024B & 35M020B Stepper Motors

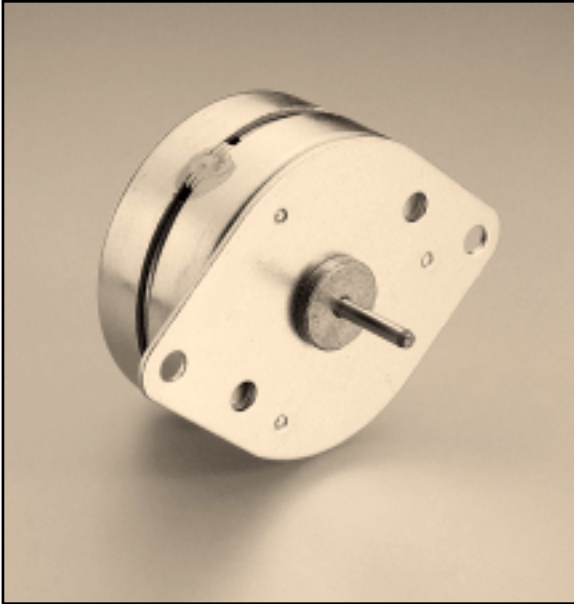

Dimensions: mm/inches

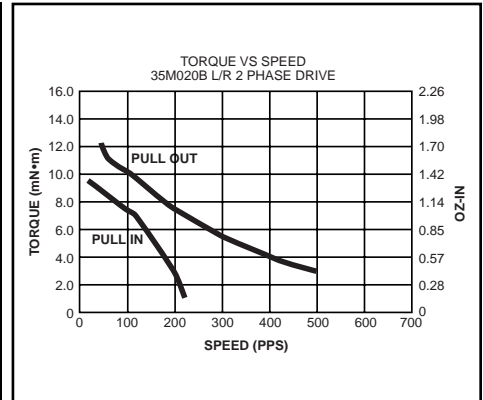
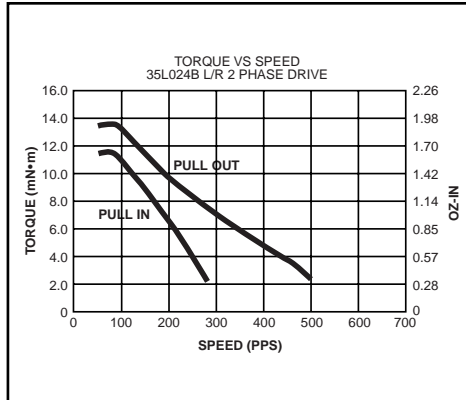
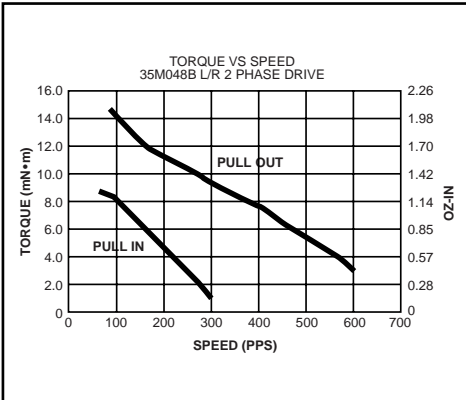
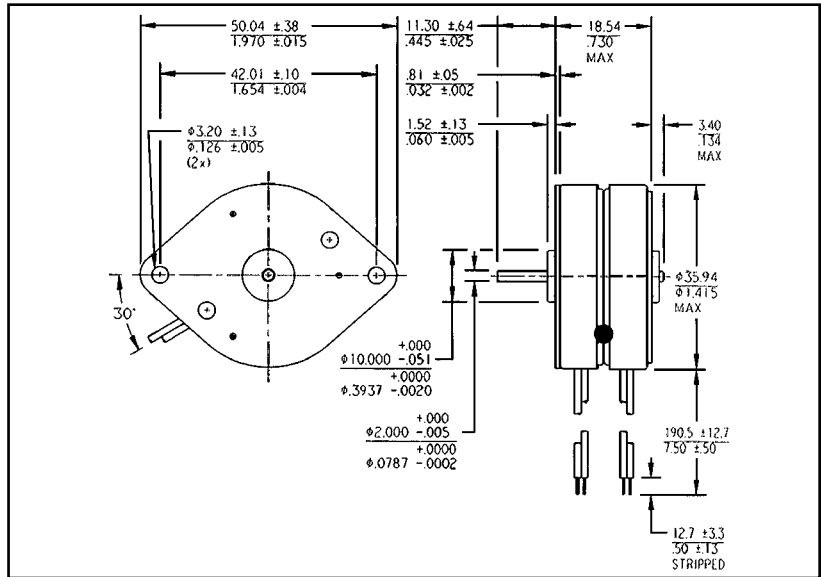

## Specifications

NOTE: Refer to page 7 for switching sequence

Part Number	35M048B1U	35M048B2U	35M024B1U	35M024B2U	35M020B1U	35M020B2U
DC Operating Voltage	5	12	5	12	5	12
Res. per Winding Ω	12.5	72	12.5	72	12.5	72
Ind. per Winding mH	7.8	36	7	34	6.6	30
Holding Torque mN•m/oz-in <sup>1</sup>	18.4/2.6		16.93/2.4		13.4/1.9	
Rotor Moment of Inertia g•m <sup>2</sup>	2 x 10 <sup>-4</sup>		2 x 10 <sup>-4</sup>		2 x 10 <sup>-4</sup>	
Detent Torque mN•m/oz-in	1.8/0.26		1.8/0.26		1.8/0.26	
Step Angle	7.5°		15.0°		18.0°	
Step Angle Tolerance <sup>†</sup>	±.5°		±1°		±1.2°	
Steps per Rev.	48		24		20	
Max Operating Temp.	100°C					
Ambient Temp Range						
Operating	-20°C to 70°C					
Storage	-40°C to 85°C					
Bearing Type	Bronze sleeve					
Insulation Res. at 500Vdc	100 megohms					
Dielectric Withstanding Voltage	650 ±50 VRMS 60 Hz for 2 seconds					
Weight g/oz	79/2.8					
Lead Wires	26 AWG					

<sup>†</sup> Measured with 2 phases energized.

For information or to place an order in North America: 1 (203) 271-6444 Europe: (44) 1276-691622 Asia: (65) 7474-888

# Series 35L048B, 35L024B & 35L020B Stepper Motors



Dimensions: mm/inches

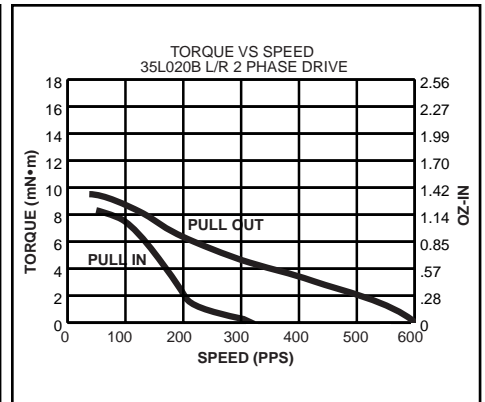
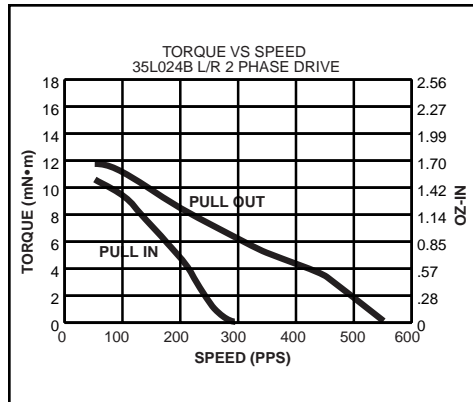
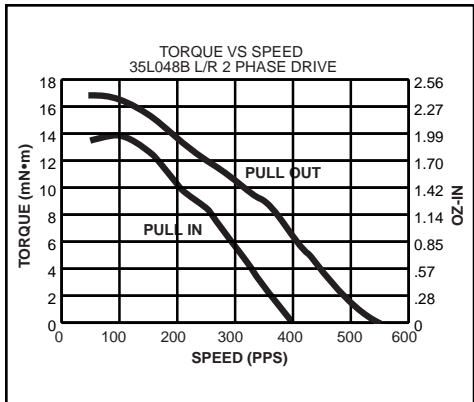
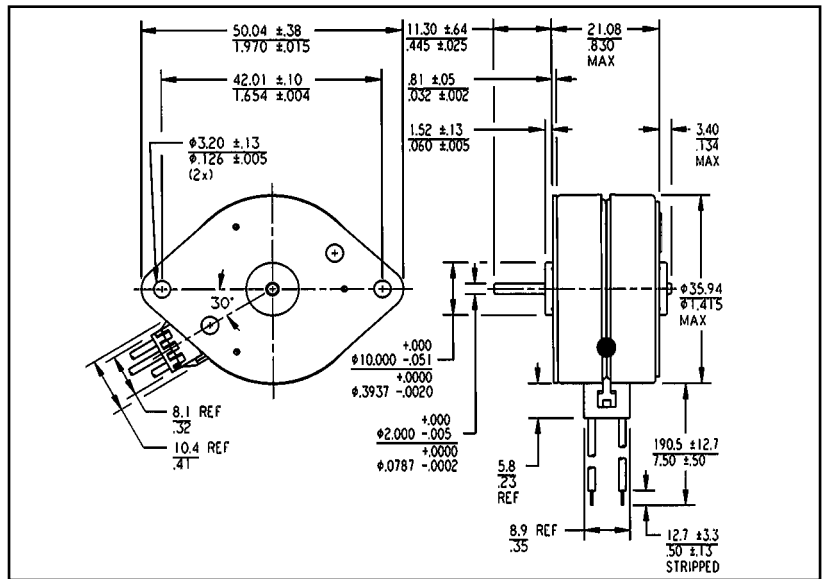

## Specifications

NOTE: Refer to page 7 for switching sequence

Part Number	35L048B1U	35L048B2U	35L024B1U	35L024B2U	35L020B1U	35L020B2U
DC Operating Voltage	5	12	5	12	5	12
Res. per Winding $\Omega$	11	64	11	64	11	64
Ind. per Winding mH	7	38	7	34	7	30
Holding Torque mN·m/oz-in†	27.5/3.9		21.1/3.0		17.7/2.5	
Rotor Moment of Inertia g·m <sup>2</sup>	$4.0 \times 10^{-4}$		$4.0 \times 10^{-4}$		$4.0 \times 10^{-4}$	
Detent Torque mN·m/oz-in	2.5/.36		2.5/.36		2.5/.36	
Step Angle	7.5°		15.0°		18.0°	
Step Angle Tolerance†	±.5°		±1°		±1.2°	
Steps per Rev.	48		24		20	
Max Operating Temp.	100°C					
Ambient Temp Range						
Operating	-20°C to 70°C					
Storage	-40°C to 85°C					
Bearing Type	Bronze sleeve					
Insulation Res. at 500Vdc	100 megohms					
Dielectric Withstanding Voltage	650 ±50 VRMS 60 Hz for 2 seconds					
Weight g/oz	88/3.1					
Lead Wires	26 AWG					

† Measured with 2 phases energized.

For information or to place an order in North America: 1 (203) 271-6444 Europe: (44) 1276-691622 Asia: (65) 7474-888

The specifications in this publication are believed to be accurate and reliable. However, it is the responsibility of the product user to determine the suitability of Thomson products for a specific application. While defective products will be replaced without charge if promptly returned, no liability is assumed beyond such replacement.



# Series 42M048C Stepper Motors



Dimensions: mm/inches

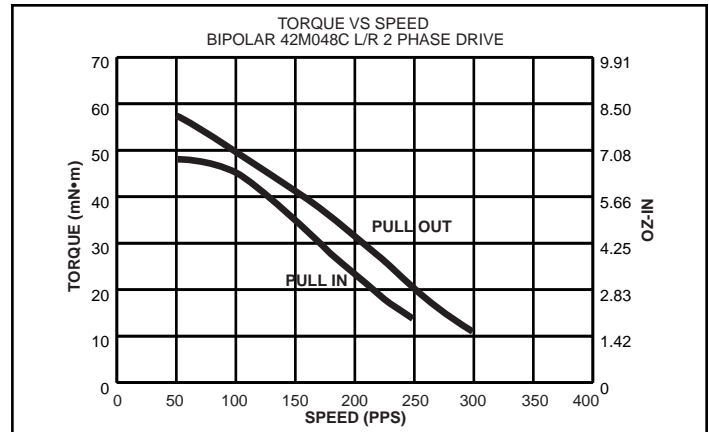
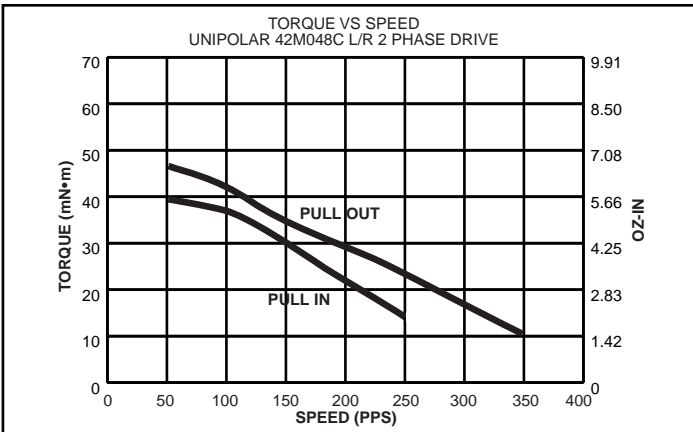
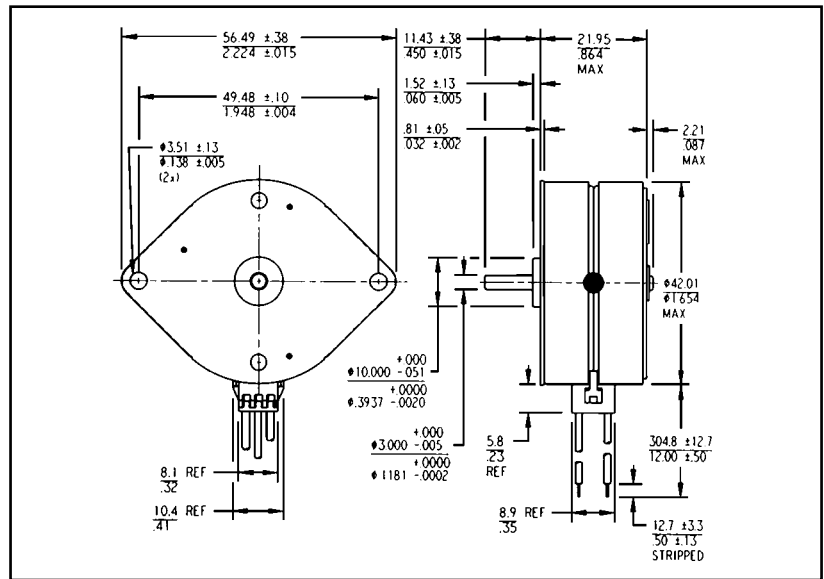

## Specifications

NOTE: Refer to page 7 for switching sequence

Part Number	Unipolar		Bipolar	
	42M048C1U	42M048C2U	42M048C1B	42M048C2B
DC Operating Voltage	5	12	5	12
Res. per Winding $\Omega$	9.1	52.4	9.1	52.4
Ind. per Winding mH	7.5	46.8	14.3	77.9
Holding Torque mN·m/oz·in <sup>†</sup>	73.4/10.4		87.5/12.4	
Rotor Moment of Inertia g·m <sup>2</sup>	12.5 x 10 <sup>-4</sup>			
Detent Torque mN·m/oz·in	9.2/1.3			
Step Angle	7.5°			
Step Angle Tolerance <sup>†</sup>	±.5°			
Steps per Rev.	48			
Max Operating Temp.	100°C			
Ambient Temp Range				
Operating	-20°C to 70°C			
Storage	-40°C to 85°C			
Bearing Type	Bronze sleeve			
Insulation Res. at 500Vdc	100 megohms			
Dielectric Withstanding Voltage	650 ±50 VRMS 60 Hz for 1 to 2 seconds			
Weight g/oz	144/5.1			
Lead Wires	26 AWG			

<sup>†</sup> Measured with 2 phases energized.

For information or to place an order in North America: 1 (203) 271-6444 Europe: (44) 1276-691622 Asia: (65) 7474-888



# Series 42M100B Stepper Motors



Dimensions: mm/inches

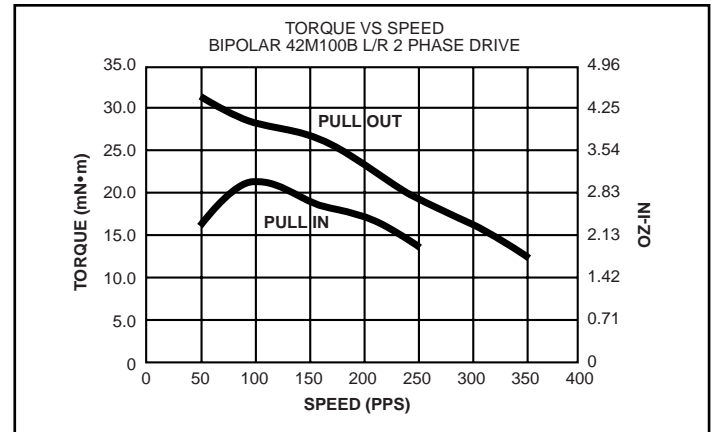
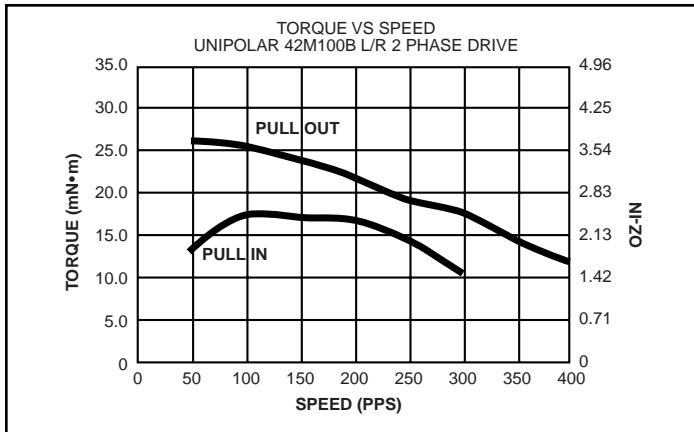
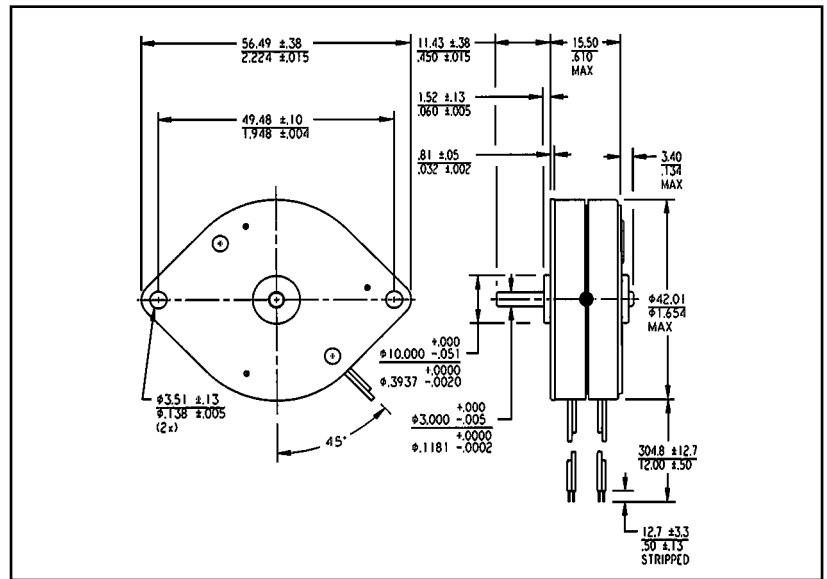

## Specifications at the Rotor

NOTE: Refer to page 7 for unipolar switching sequence

Part Number	Unipolar		Bipolar	
	42M100B1U	42M100B2U	42M100B1B	42M100B2B
DC Operating Voltage	5	12	5	12
Res. per Winding $\Omega$	12.5	75	12.5	75
Ind. per Winding mH	6.6	37.7	11.3	62.1
Holding Torque mN·m/oz-in <sup>†</sup>	45.2/6.4		49.4/7.0	
Rotor Moment of Inertia g·m <sup>2</sup>	11.8 x 10 <sup>-4</sup>			
Detent Torque mN·m/oz-in	5.0/0.7			
Step Angle	3.6°			
Step Angle Tolerance <sup>†</sup>	±0.25°			
Steps per Rev.	100			
Max Operating Temp.	100°C			
Ambient Temp Range				
Operating	-20°C to 70°C			
Storage	-40°C to 85°C			
Bearing Type	Bronze sleeve			
Insulation Res. at 500Vdc	100 megohms			
Dielectric Withstanding Voltage	650 ±50 VRMS 60 Hz for 1 to 2 seconds			
Weight g/oz	88/3.1			
Lead Wires	28 AWG			

<sup>†</sup> Measured with 2 phases energized.

For information or to place an order in North America: 1 (203) 271-6444 Europe: (44) 1276-691622 Asia: (65) 7474-888

The specifications in this publication are believed to be accurate and reliable. However, it is the responsibility of the product user to determine the suitability of Thomson products for a specific application. While defective products will be replaced without charge if promptly returned, no liability is assumed beyond such replacement.



# Series 57L048B, 57M024B & 57M048B Stepper Motors



Dimensions: mm/inches

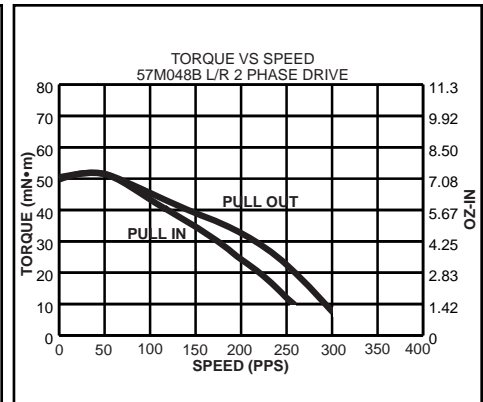
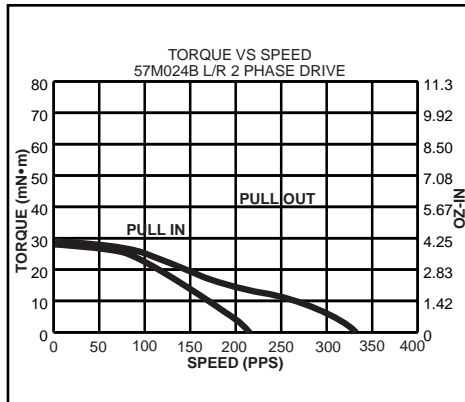
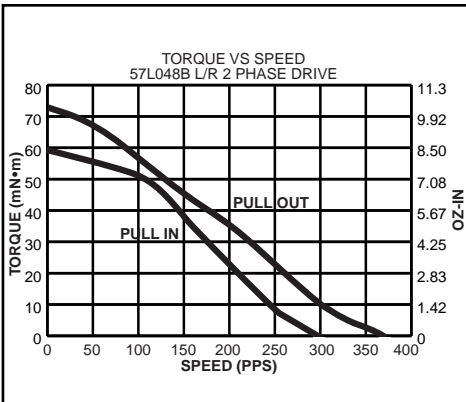
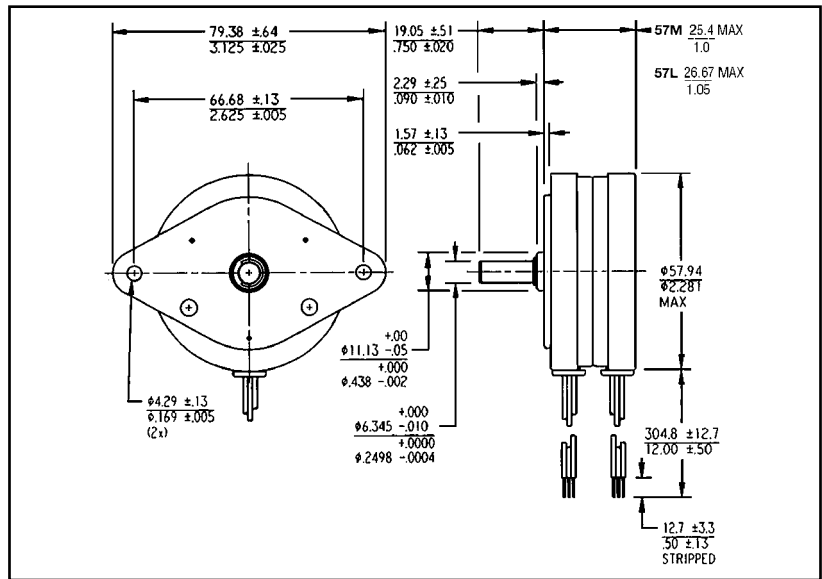

## Specifications

NOTE: Refer to page 7 for switching sequence

Part Number	57L048B1U	57L048B2U	57M024B1U	57M024B2U	57M048B1U	57M048B2U
DC Operating Voltage	5	12	5	12	5	12
Res. per Winding Ω	6.3	36	6.3	36	6.3	36
Ind. per Winding mH	7.0	38	4.5	24	5.0	26
Holding Torque mN·m/oz·in <sup>†</sup>	205/25.0		55/7.8		74/10.5	
Rotor Moment of Inertia g·m <sup>2</sup>	3.4 x 10 <sup>-3</sup>		3.1 x 10 <sup>-3</sup>		3.1 x 10 <sup>-3</sup>	
Detent Torque mN·m/oz·in	9.9/1.4		9.9/1.4		9.9/1.4	
Step Angle	7.5°		15.0°		7.5°	
Step Angle Tolerance <sup>†</sup>	±.5°		±1°		±.5°	
Steps per Rev.	48		24		48	
Max Operating Temp.	100°C					
Ambient Temp Range						
Operating	-20°C to 70°C					
Storage	-40°C to 85°C					
Bearing Type	Bronze sleeve					
Insulation Res. at 500Vdc	100 megohms					
Dielectric Withstanding Voltage	650 ± 50 VRMS 60 Hz for 2 seconds					
Weight g/oz	281/9.9		239/8.4		239/8.4	
Lead Wires	26 AWG		26 AWG		26 AWG	

<sup>†</sup> Measured with 2 phases energized.

For information or to place an order in North America: 1 (203) 271-6444 Europe: (44) 1276-691622 Asia: (65) 7474-888

# Series 60L048B & 60L024B Stepper Motors

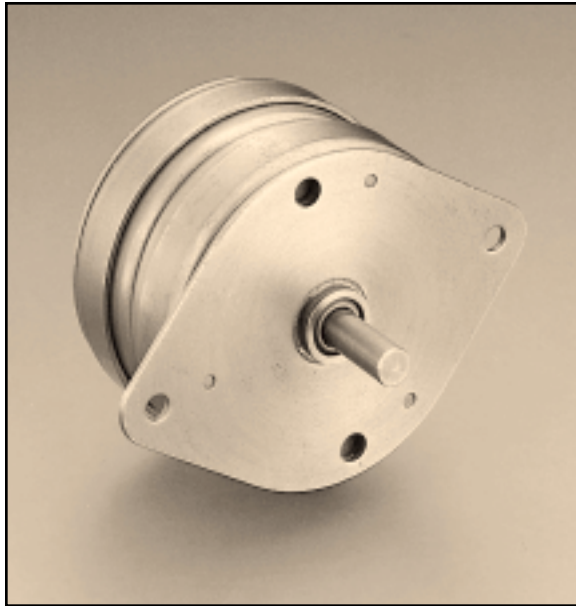

Dimensions: mm/inches

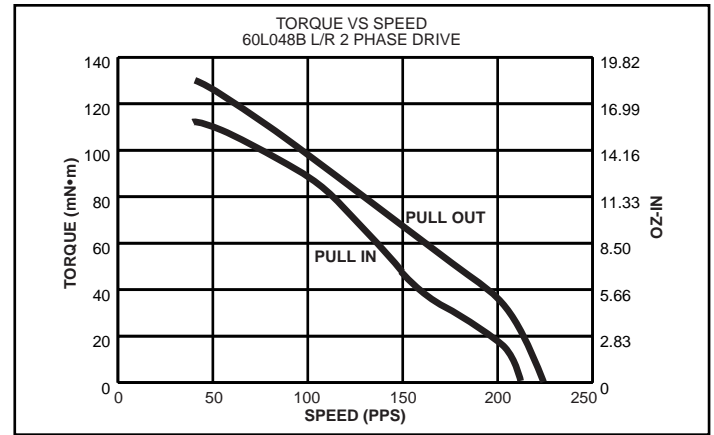
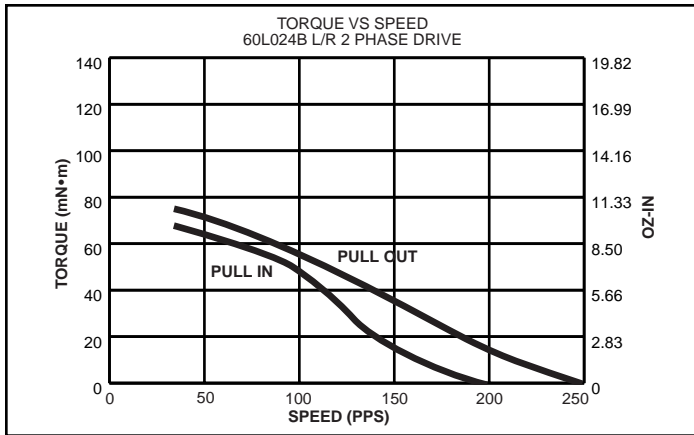
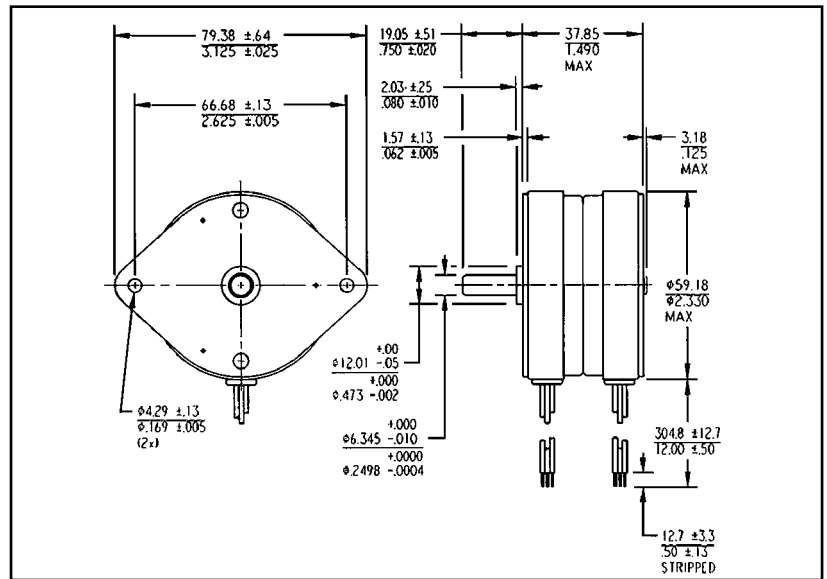

## Specifications

NOTE: Refer to page 7 for switching sequence

Part Number	60L048B1U	60L048B2U	60L024B1U	60L024B2U
DC Operating Voltage	5	12	5	12
Res. per Winding $\Omega$	4.6	26	4.6	26
Ind. per Winding mH	6.0	33	5.4	29
Holding Torque mN·m/oz·in <sup>†</sup>	198/28		141/20	
Rotor Moment of Inertia g·m <sup>2</sup>	$9.5 \times 10^{-3}$		$9.5 \times 10^{-3}$	
Detent Torque mN·m/oz·in	21.2/3.0		21.2/3.0	
Step Angle	7.5°		15°	
Step Angle Tolerance <sup>†</sup>	±.5°		±1.0°	
Steps per Rev.	48		24	
Max Operating Temp.	100°C			
Ambient Temp Range				
Operating	-0°C to 60°C			
Storage	-40°C to 85°C			
Bearing Type	Bronze sleeve			
Insulation Res. at 500Vdc	100 megohms			
Dielectric Withstanding Voltage	650 ±50 VRMS 60 Hz for 2 seconds			
Weight g/oz	440/15.5			
Lead Wires	24 AWG			

<sup>†</sup> Measured with 2 phases energized.

For information or to place an order in North America: 1 (203) 271-6444 Europe: (44) 1276-691622 Asia: (65) 7474-888

The specifications in this publication are believed to be accurate and reliable. However, it is the responsibility of the product user to determine the suitability of Thomson products for a specific application. While defective products will be replaced without charge if promptly returned, no liability is assumed beyond such replacement.



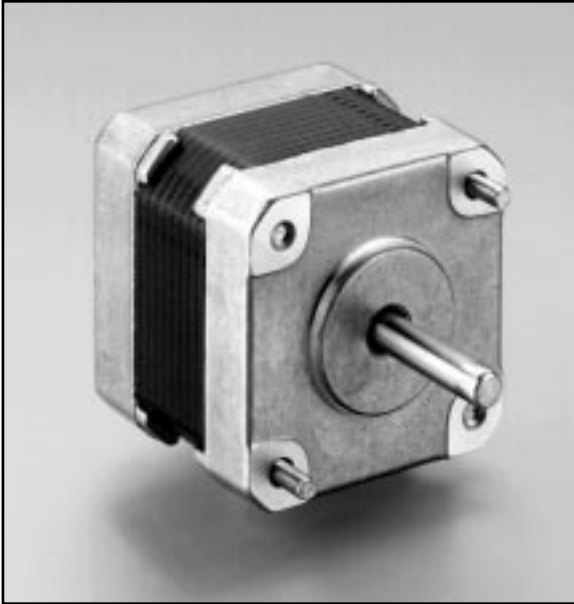

Dimensions: mm/in

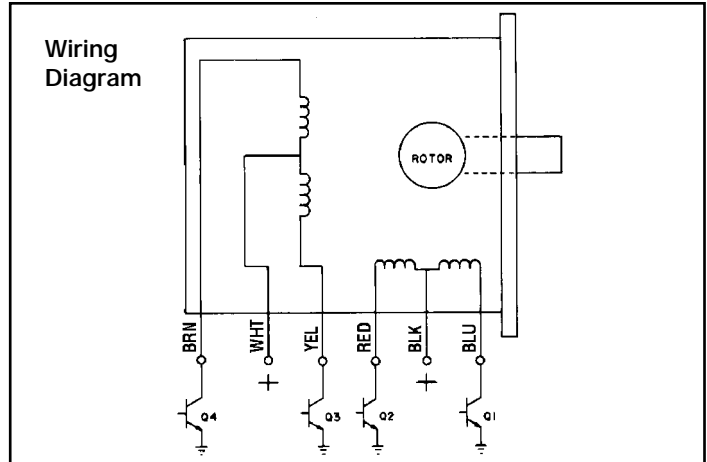
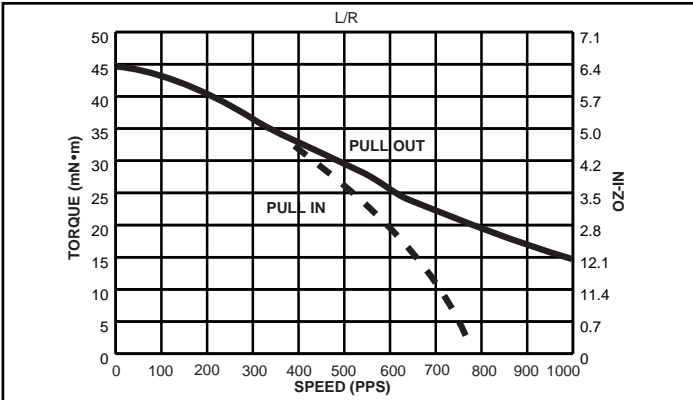
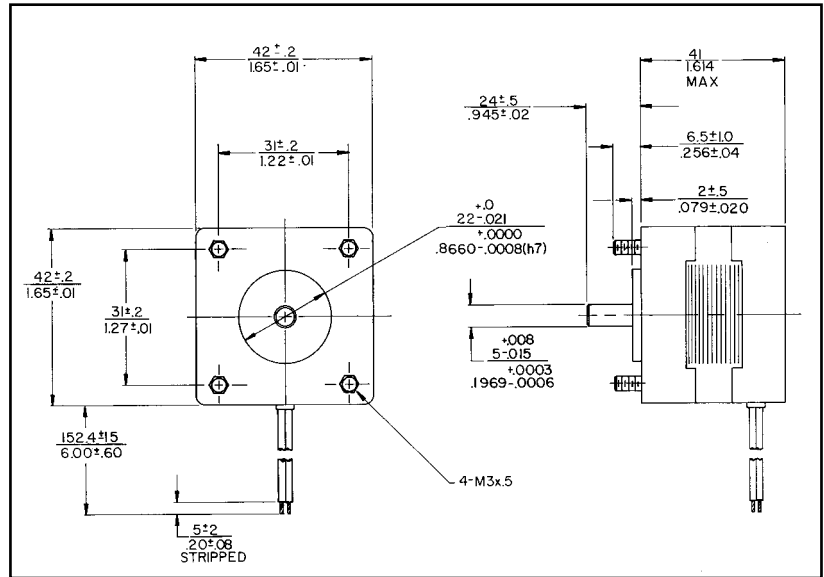

NOTE: Refer to page 7 for unipolar switching sequence

Specifications

Part Number	4SQ - 120B34S
DC Operating Voltage	12
Res. per Winding $\Omega$	5
Ind. per Winding mH	26
Holding Torque mN·m/oz-in <sup>†</sup>	65/9.2
Rotor Moment of Inertia g·m <sup>2</sup>	$1.9 \times 10^{-3}$
Detent Torque mN·m/oz-in	8.5/01.2
Step Angle	1.8°
Step Angle Tolerance <sup>†</sup>	±5%
Steps per Rev.	200
Max. Radial Load <sup>††</sup> kg/lb	4/8.8
Max. Axial Load kg/lb	8/17.6
Max. Temp. Rise	55°C
Ambient Temp Range	
Operating	-20°C to +50°C
Storage	-20°C to +60°C
Bearing Type	Bal, Double Shielded
Insulation Res. at 500Vdc	50 megohms
Dielectric Withstanding Voltage	500 Vac for 60 Sec
Weight g/oz	195/7

NOTE: Unless otherwise indicated all values shown are typical. Other windings available on special order. Consult Thomson Airpax for availability of motors with 3.6° step angle.

<sup>†</sup> Measured with 2 phases energized. <sup>††</sup> Measured at 10mm from mounting plate surface

Catalog P/N Construction

Example 1. Single Shaft Extension

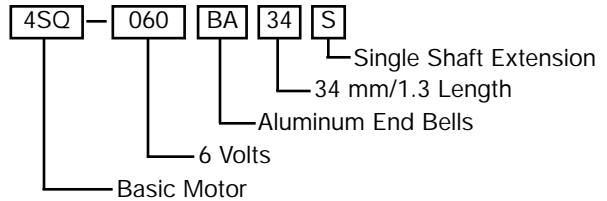

Example 2. Double Shaft Extension

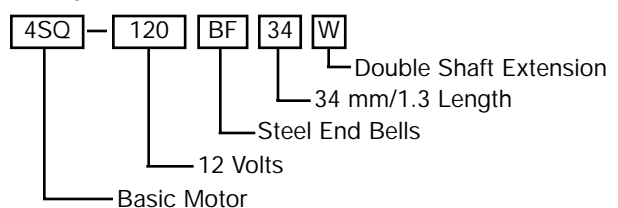

For information or to place an order in North America: 1 (203) 271-6444 Asia: (65) 7474-888

# Series 4SHG Stepper Motors 1.8° Not available for sale in Europe



Dimensions: mm/inches

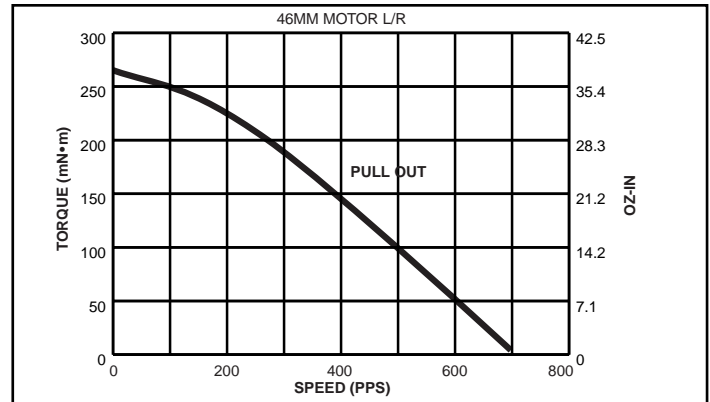
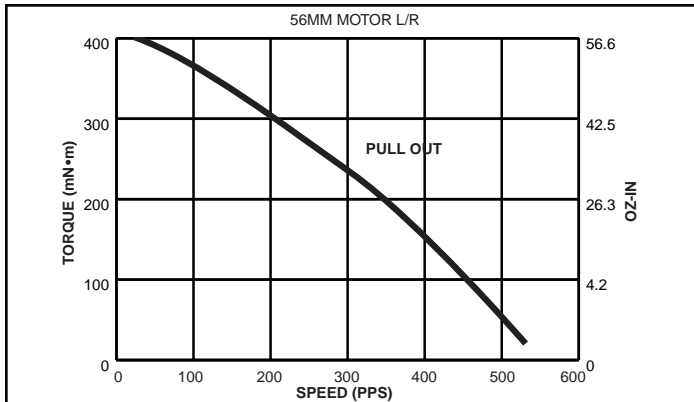
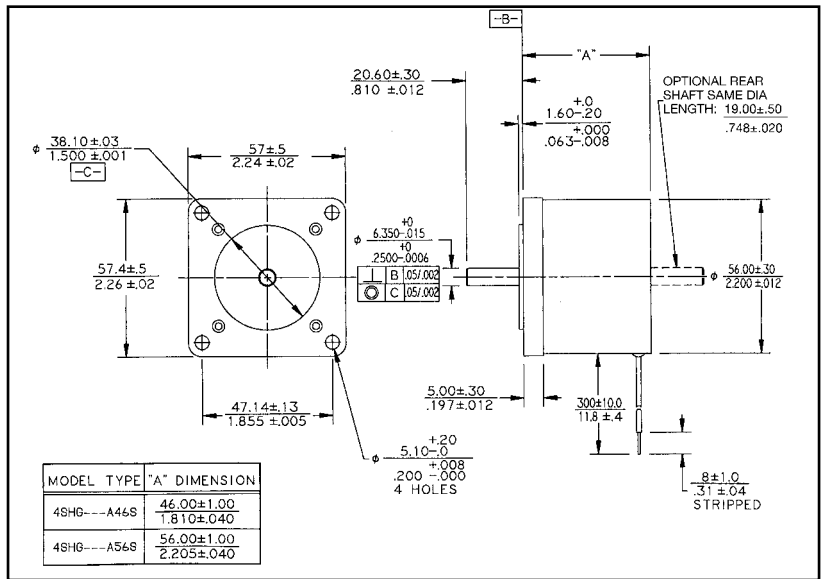

## Specifications

NOTE: Refer to page 7 for unipolar switching sequence

Part Number (For optional Rear Shaft, Remove Suffix "S" and Replace with Suffix "W")	(46 mm)			(56 mm)		
	4SHG 060A46S	4SHG 120A46S	4SHG 240A46S	4SHG 060A56S	4SHG 120A56S	4SHG 240A56S
DC Operating Voltage	6	12	24	6	12	24
Res. per Winding Ω	7	27	104	4.7	20.5	79
Ind. per Winding mH	8.6	30	89	9	45	150
Holding Torque mN·m/oz-in <sup>1</sup>	388/55	388/55	353/50	600/85	600/85	600/85
Rotor Moment of Inertia g·m <sup>2</sup>	1 x 10 <sup>-2</sup>			1.67 x 10 <sup>-2</sup>		
Detent Torque mN·m/oz-in	49.4/7					
Step Angle	1.8°					
Step Angle Tolerance <sup>†</sup>	±5%					
Steps per Rev.	200					
Max. Radial Load <sup>††</sup> kg/lb	7/15.4					
Max. Axial Load kg/lb	12/26.4					
Max Temp. Rise	80°C					
Ambient Temp Range						
Operating	-20°C to 50°C					
Storage	-20°C to 60°C					
Bearing Type	Ball, Double Shielded					
Insulation Res. at 500Vdc	50 megohms					
Dielectric Withstanding Voltage	500 Vac for 60 seconds					
Weight g/oz	450/16			610/21.5		

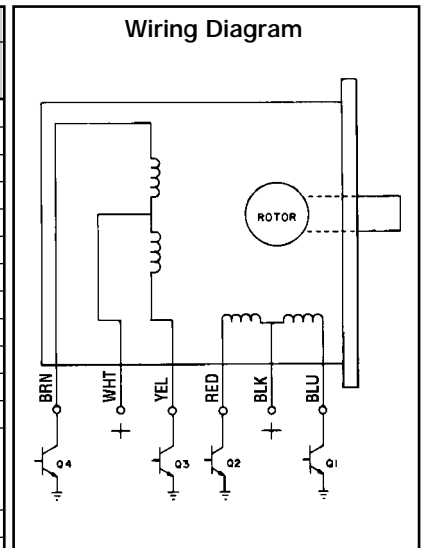

<sup>1</sup> Measured with 2 phases energized. <sup>††</sup> Measured at 10mm from mounting plate surface

For information or to place an order in North America: 1 (203) 271-6444

Asia: (65) 7474-888

The specifications in this publication are believed to be accurate and reliable. However, it is the responsibility of the product user to determine the suitability of Thomson products for a specific application. While defective products will be replaced without charge if promptly returned, no liability is assumed beyond such replacement.



# Series 26M048B Stepper Motors With Gear Trains (Type V)



Dimensions: mm/in

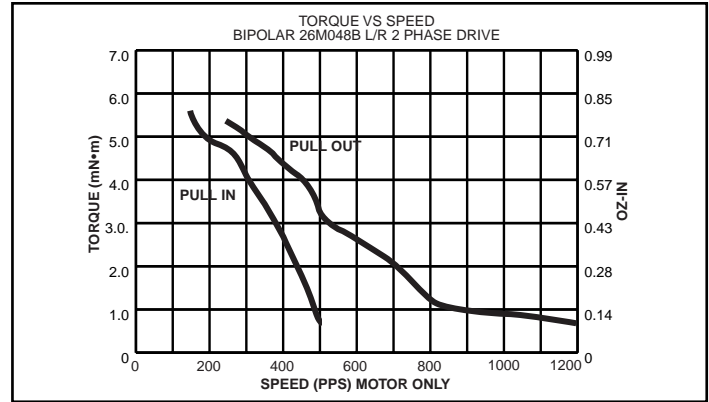
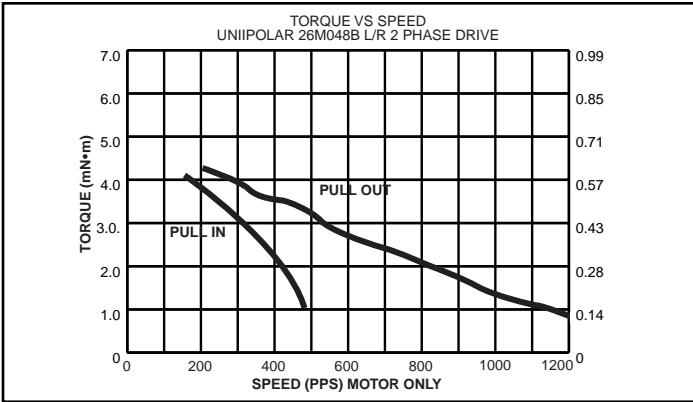
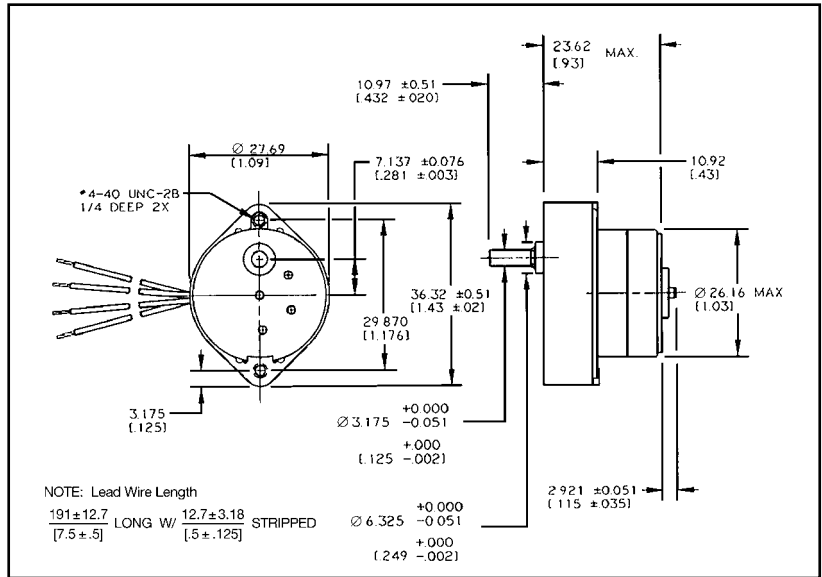

## Specifications (Motor Only)

Part Number	Unipolar		Bipolar	
	26M048B1U	26M048B2U	26M048B1B	26M048B2B
DC Operating Voltage	5	12	5	12
Res. per Winding Ω	19.6	110	19.8	108
Ind. per Winding mH	5.3	36.5	13.0	60.7
Holding Torque mN·m/oz-in <sup>1</sup>	9.2/1.3		10.6/1.5	
Rotor Moment of Inertia g·m <sup>2</sup>	1.1 x 10 <sup>-4</sup>			
Detent Torque mN·m/oz-in	0.85/0.12			
Step Angle	7.5°			
Step Angle Tolerance <sup>1</sup>	±.5°			
Steps per Rev.	48			
Max Operating Temp.	100°C			
Ambient Temp Range				
Operating	-20°C to 70°C			
Storage	-40°C to 85°C			
Bearing Type	Bronze sleeve			
Insulation Res. at 500Vdc	100 megohms			
Dielectric Withstanding Voltage	650±50 VRMS 60 Hz for 1 to 2 seconds			
Weight g/oz	57.2/2			
Lead Wires	28 AWG			

<sup>1</sup> Measured with 2 phases energized.

## Available Gear Train Reductions

Part Suffix	Gear Ratio	Output Step Angle	Output Speed RPM @ 100 PPS	Running Torque @ 100 PPS mN·m/oz-in
-V11	2:1	3.75°	62.50	8.9/1.16
-V16	5:1	1.5°	25.00	17.01/2.41
-V19	7.5:1	1.00°	16.66	21.08/3.00
-V21	10:1	.75°	12.50	28.24/4.00
-V24	15:1	.5°	8.33	35.30/5.00
-V27	20:1	.375°	6.25	46.88/6.64
-V31	30:1	.25°	4.17	70.6/10.00
-V37	60:1	.125°	2.09	112.96/16.00

### How to Order

- List Series 26M048B.
- Add suffix -V11 to V37 for desired gear ratio.

### Examples of Part Numbers

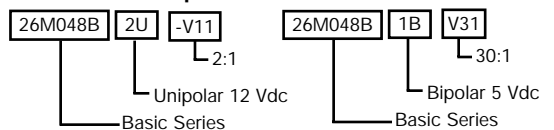

For information or to place an order in North America: 1 (203) 271-6444 Europe: (44) 1276-691622 Asia: (65) 7474-888

# Series 35M048B Stepper Motors With Gear Trains (Type X)



Dimensions: mm/in

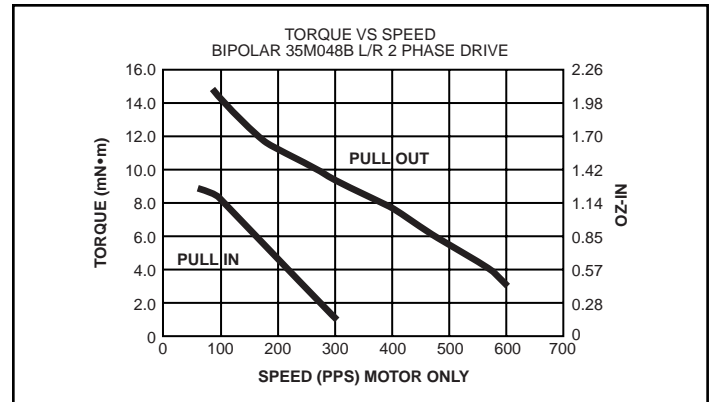
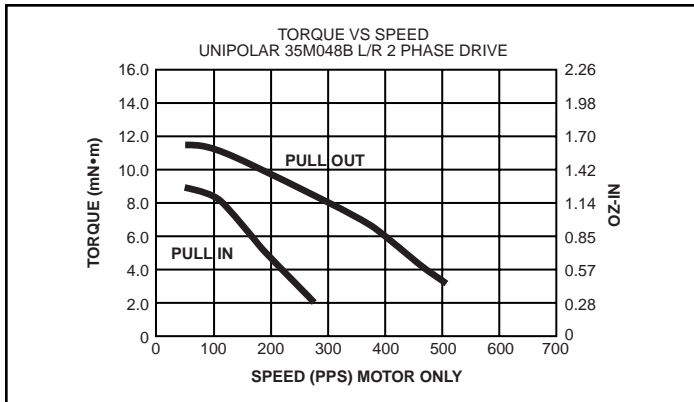
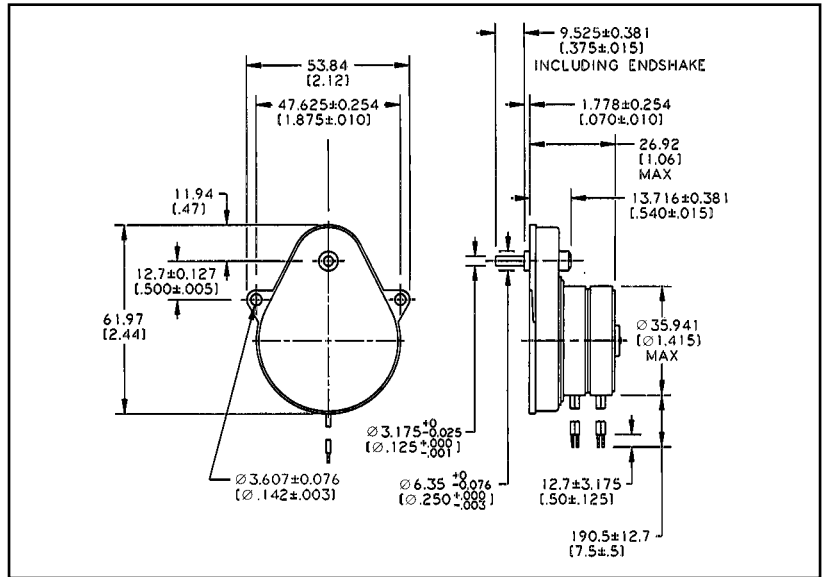

## Specifications (Motor Only)

Part Number	Unipolar		Bipolar	
	35M048B1U	35M048B2U	35M048B1B	35M048B2B
DC Operating Voltage	5	12	5	12
Res. per Winding Ω	12.5	72	12.5	72
Ind. per Winding mH	7.8	36	16.4	86.0
Holding Torque mN•m/oz-in <sup>†</sup>	18.4/2.6		10.6/1.5	
Rotor Moment of Inertia g•m <sup>2</sup>	2 x 10 <sup>-4</sup>			
Detent Torque mN•m/oz-in	1.8/0.26			
Step Angle	7.5°			
Step Angle Tolerance <sup>†</sup>	±.5°			
Steps per Rev.	48			
Max Operating Temp.	100°C			
Ambient Temp Range				
Operating	-20°C to 70°C			
Storage	-40°C to 85°C			
Bearing Type	Bronze sleeve			
Insulation Res. at 500Vdc	100 megohms			
Dielectric Withstanding Voltage	650±50 VRMS 60 Hz for 1 to 2 seconds			
Weight g/oz	142/5			
Lead Wires	26 AWG			

<sup>†</sup> Measured with 2 phases energized.

## Available Gear Train Reductions

Part Suffix	Gear Ratio	Output Step Angle	Output Speed RPM @ 240 PPS	Running Torque @ 240 PPS mN•m/oz-in
-X24	15:1	.500°	20	35.3/5.0 MAX <sup>††</sup>
-X27	20:1	.375°	15	
-X31	30:1	.250°	10	
-X37	60:1	.1250°	5	
-X39	75:1	.1000°	4	
-X45	150:1	.0500°	2	
-X52	300:1	.0250°	1	
-X64	1350:1	.0055°	.222	

<sup>††</sup> Higher ratings available.

## How to Order

- List Series 35M048B.
- Add suffix -X24 to -X64 for desired gear ratio.

## Examples of Part Numbers

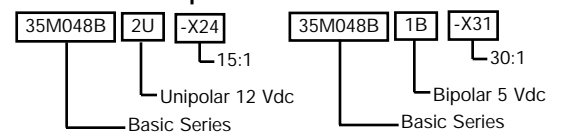

For information or to place an order in North America: 1 (203) 271-6444 Europe: (44) 1276-691622 Asia: (65) 7474-888

The specifications in this publication are believed to be accurate and reliable. However, it is the responsibility of the product user to determine the suitability of Thomson products for a specific application. While defective products will be replaced without charge if promptly returned, no liability is assumed beyond such replacement.

# Series 42M048C Stepper Motors With Gear Trains (Type R)



Dimensions: mm/inches

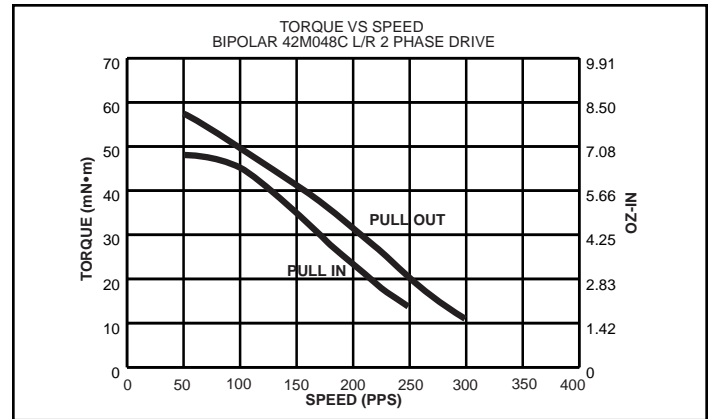
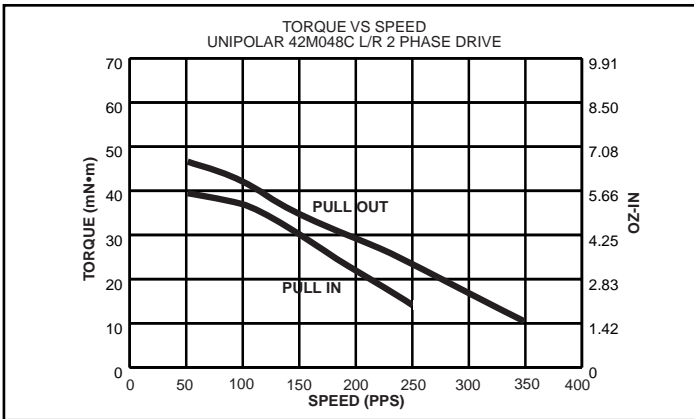
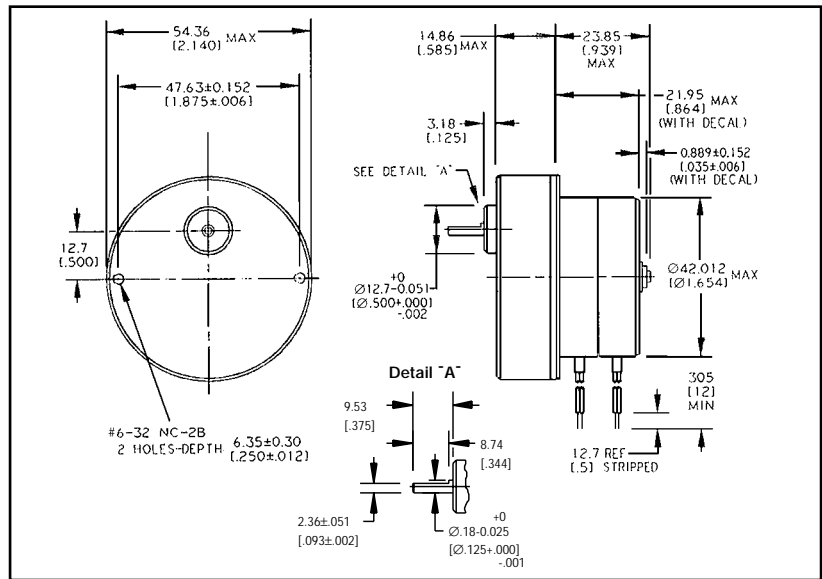

## Specifications (Motor Only)

Part Number	Bipolar		Unipolar	
	42M048C1B	42M048C2B	42M048C1U	42M048C2U
DC Operating Voltage	5	12	5	12
Res. per Winding Ω	9.1	52.4	9.1	52.4
Ind. per Winding mH	14.3	77.9	7.5	46.8
Holding Torque mN·m/oz-in <sup>1</sup>	87.5/12.4		73.4/10.4	
Rotor Moment of Inertia g·m <sup>2</sup>	12.5 x 10 <sup>-4</sup>			
Step Angle	7.5°			
Step Angle Tolerance <sup>†</sup>	±0.5°			
Steps per Rev.	48			
Max Operating Temp.	100°C			
Ambient Temp Range				
Operating	-20°C to 70°C			
Storage	-40°C to 85°C			
Bearing Type	Bronze sleeve			
Insulation Res. at 500Vdc	100 megohms			
Weight g/oz	312/11.0			
Lead Wires	No. 26 AWG			

<sup>1</sup> Measured with 2 phases energized.

## Available Gear Train Reductions

Part Suffix	Gear Ratio	Output Step Angle	Output Speed RPM @240 PPS	Running Torque @ 240 PPS N·m/oz-in
-R12	2.5:1	3.00°	50	0.078/11
-R16	5:1	1.50°	25	0.155/22
-R21	10:1	.75°	12.5	0.318/45
-R24	15:1	.50°	8.33	0.473/67
-R27	20:1	.375°	6.25	0.635/90
-R31	30:1	.25°	4.17	0.706/100 max
-R36	50:1	.15°	2.5	0.706/100 max
-R39	75:1	.10°	1.67	0.706/100 max

### How to Order

1. List Series 42M048C.
2. Add suffix -R12 to -R39 for round diecast.

### Example of Part Numbers

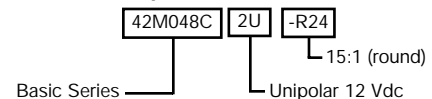

For information or to place an order in North America: 1 (203) 271-6444 Europe: (44) 1276-691622 Asia: (65) 7474-888



# Series 42M048C Stepper Motors With Gear Trains (Type Z)



## Dimensions: mm/inches

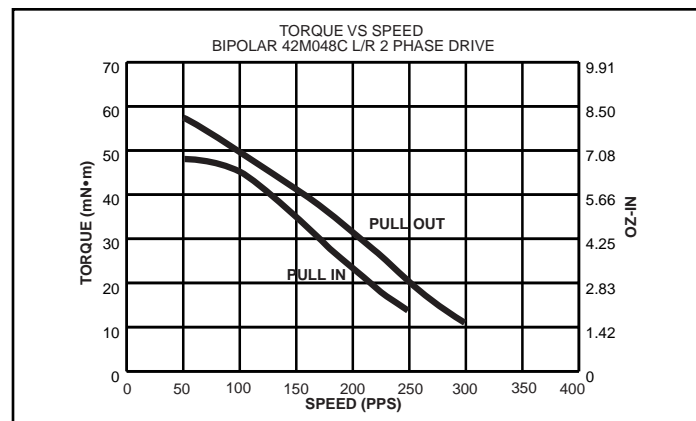
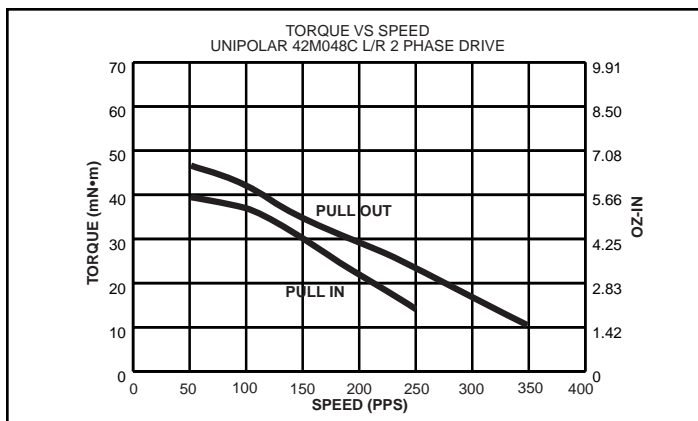
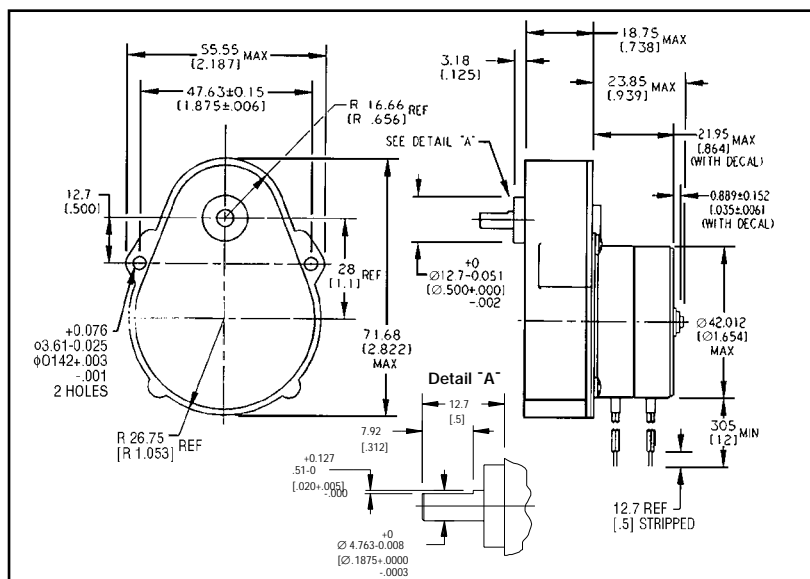

## Specifications (Motor Only)

Part Number	Bipolar		Unipolar	
	42M048C1B	42M048C2B	42M048C1U	42M048C2U
DC Operating Voltage	5	12	5	12
Res. per Winding $\Omega$	9.1	52.4	9.1	52.4
Ind. per Winding mH	14.3	77.9	7.5	46.8
Holding Torque mN•m/oz-in <sup>1</sup>	87.5/12.4		73.4/10.4	
Rotor Moment of Inertia g•m <sup>2</sup>	12.5 x 10 <sup>-4</sup>			
Step Angle	7.5°			
Step Angle Tolerance <sup>†</sup>	±0.5°			
Steps per Rev.	48			
Max Operating Temp.	100°C			
Ambient Temp Range				
Operating	-20°C to 70°C			
Storage	-40°C to 85°C			
Bearing Type	Bronze sleeve			
Insulation Res. at 500Vdc	100 megohms			
Weight g/oz	312/11.0			
Lead Wires	No. 26 AWG			

<sup>†</sup> Measured with 2 phases energized.

## Available Gear Train Reductions

Part Suffix	Gear Ratio	Output Step Angle	Output Speed RPM @ 240 PPS	Running Torque @240 PPS N•m/oz-in
-Z16	5:1	1.50°	25	0.155/22
-Z21	10:1	.75°	12.5	0.318/45
-Z24	15:1	.50°	8.33	0.473/67
-Z27	20:1	.375°	6.25	0.635/90
-Z31	30:1	.25°	4.17	0.953/135
-Z36	50:1	.15°	2.5	1.412/200 max

### How to Order

1. List Series 42M048C.
2. Add suffix -Z16 to -Z36 for pear diecast gearbox.

### Example of Part Numbers

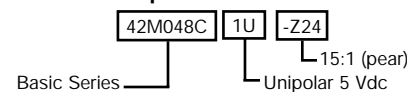

For information or to place an order in North America: 1 (203) 271-6444 Europe: (44) 1276-691622 Asia: (65) 7474-888

The specifications in this publication are believed to be accurate and reliable. However, it is the responsibility of the product user to determine the suitability of Thomson products for a specific application. While defective products will be replaced without charge if promptly returned, no liability is assumed beyond such replacement.

# Stepper Motor Terminology

---

**Step Angle:** The nominal angle that the motor shaft rotates for each winding polarity change.

**Step Accuracy:** The per step deviation from the nominal step angle of an unloaded motor. May be expressed as a percent or in degrees.

**Holding Torque:** The torque required to deflect the rotor a full step with the motor energized and in a standstill condition.

**Residual Torque:** The non-energized detent torque due to the effects of the permanent magnet and bearing friction.

**Pull Out Torque:** The maximum torque load that the motor can drive, at a fixed frequency, without losing synchronism.

**Pull In Torque:** The maximum torque load the motor can start and stop with, at a fixed frequency, without loss of a step.

**Pull In Rate:** The stepping rate at which a motor with no external load inertia can start and stop without losing a step.

**Ramping:** A control method used to vary the pulse rate to accelerate from zero steps per second to the running rate, or from any step rate to a different rate — whether it is accelerating or decelerating.

**Torque-To-Inertia Ratio:** The holding torque of a motor divided by the rotor inertia. This ratio is sometimes used to relate the step response of one motor size or design to another.

**Step Response:** The motor shaft rotational response to a step command related to time.

**Overshoot:** The amount the motor shaft may rotate beyond the step angle before it comes to rest at the step angle position.

**Drive:** The switching circuitry which controls the stepper motor.

**Pulse Rate:** The rate, pulses per second, at which pulses are fed to a drive. In most cases, the pulse rate is the stepping rate or running rate.

For information or to place an order in North America: 1 (203) 271-6444 Europe: (44) 1276-691622 Asia: (65) 7474-888

# Introduction to Digital Linear Actuators

Thomson Airpax Mechatronics manufactures digital linear actuators (DLA's). These are modified rotary stepper motors, with rotors that include a molded thread that mates to an externally threaded shaft (lead screw). Rotary motion is converted to linear movement, with the travel per step determined by the pitch of the lead screw and step angle of the motor.

- High linear resolution in a complete solution package
- Ideal for fast and precise positioning
- Available in three package sizes based on our  $\phi 26\text{mm}$ ,  $\phi 35\text{mm}$  and  $\phi 57\text{mm}$  stepper motors
- Available in linear travel per step .001" (.025mm) to .004" (.102mm)
- Available with output force up to 20 lb (89 Newtons)

Thomson Airpax Mechatronics DLA products are ideally suited for applications such as:

- Computer Peripherals
- HVAC
- Instrumentation
- Office Automation
- Medical

*Call or E-Mail and discuss your application with an expert*

North America: 1 (203) 271-6444  
motorinfo@snet.net

Europe: (44) 1276-691622  
info@tammail.com

Asia: (65) 7474-888  
airpax@tamsales.com.sg

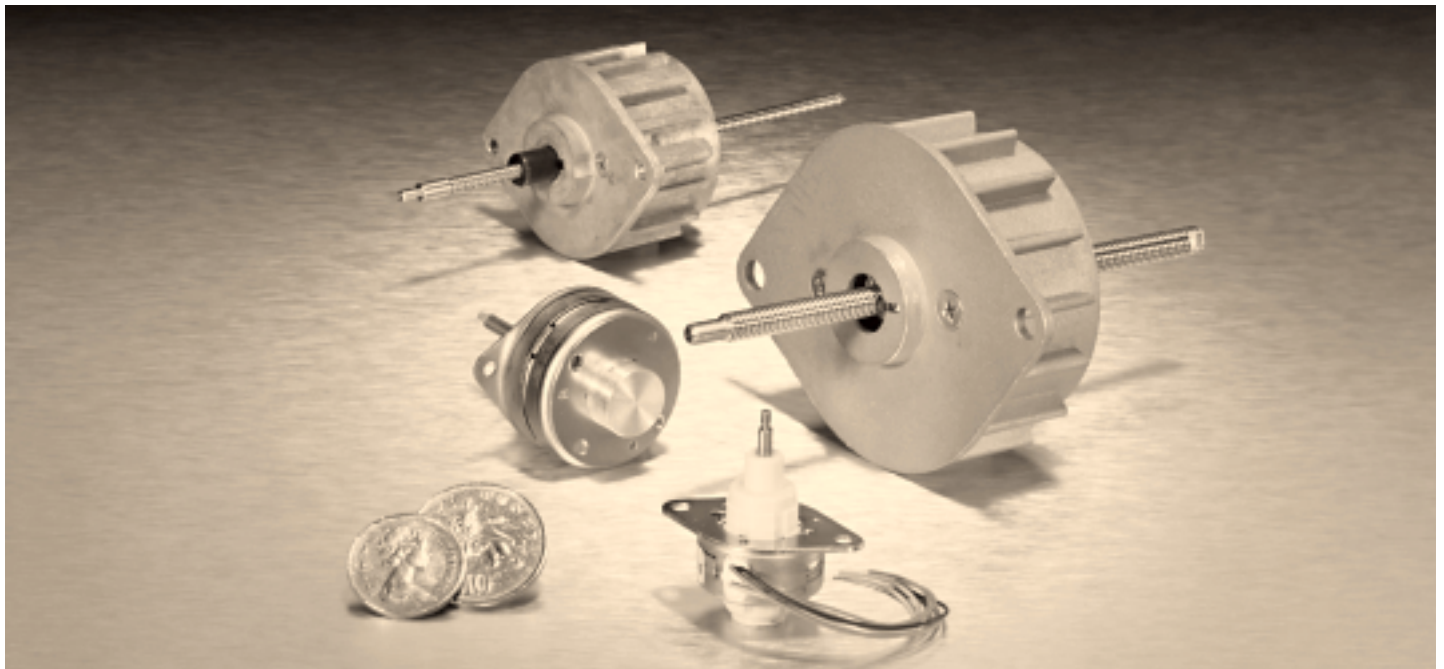

## Standard Switching Sequence for Linear Actuators – Unipolar Drive 5Vdc and 12Vdc

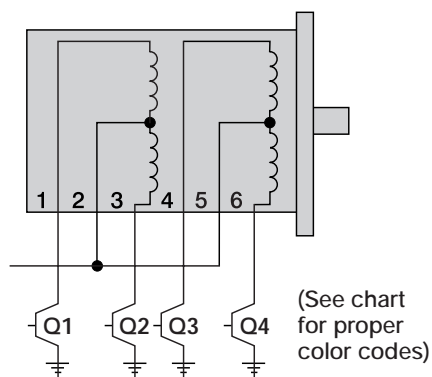

	Q1	Q2	Q3	Q4	
OUT	ON	OFF	ON	OFF	↑
	ON	OFF	OFF	ON	
	OFF	ON	OFF	ON	
	OFF	ON	ON	OFF	
	Unipolar Drive				↓

**Note:** Chart sequence repeats after four pulses. For outward thrust, use switching from top of chart to bottom. For inward thrust, use switching from bottom of chart to top.

### Lead Wire Color Codes

Series	Q1	Q2	Q3	Q4	+V
92100 5V & 12V	YEL	ORN	BLK	BRN	RED (2) GRN (5)
92200 5V	GRN	GRY	BLU	WHT	RED
92200 12V	YEL	BLK	ORN	BRN	RED
92400 5V	GRN	GRY	BLU	WHT	RED
92400 12V	YEL	BLK	ORN	BRN	RED

# Series K92100 & L92100 Digital Linear Actuators



## Series 92100 Digital Linear Actuators

The Series 92100 bidirectional linear actuator is a stepper motor that has been modified by incorporating a pre-loaded ball bearing and an internally threaded rotor with a lead screw shaft. Energizing the unit's coil in proper sequence will cause the threaded shaft to move out or back into the rotor in linear increments of .001", .002" or .004" per pulse.

The actuator shaft will remain in position when power is removed. The actuator shaft of the Series K92100 has a maximum travel of 1/2". Maximum travel of the Series L92100 shaft is 1 7/8". The *Linear Force Chart* shows typical forces available vs. pulse rates. "K" units contain an integral anti-rotational shaft feature. "L" units require an external means of preventing shaft rotation.

These devices are particularly useful for applications, such as valve actuators, variable displacement pumps, etc., where rapid movement to a particular linear position is required. Actuators for applications requiring different step increments, force outputs or extended travel can be provided on a special basis. Please supply us with complete specifications of your requirements.

## Specifications

Part Number	DC Operating Voltage	Maximum Travel	Linear Travel Per Step	Maximum Force	Minimum Holding Force (Unenergized)
K92111-P1	5	0.5" (12.7mm)	.001" (.025mm)	45 oz (12.5N)	60 oz (16.68N)
K92111-P2	12				
L92111-P1	5	1.875" (47.6mm)			
L92111-P2	12				
K92121-P1	5	0.5" (12.7mm)	.002" (.05mm)	26 oz (7.23N)	40 oz (11.13N)
K92121-P2	12				
L92121-P1	5	1.875" (47.6mm)			
L92121-P2	12				
K92141-P1	5	0.5" (12.7mm)	.004" (.10mm)	16 oz (4.45N)	7 oz (1.95N)
K92141-P2	12				
L92141-P1	5	1.875" (47.6mm)			
L92141-P2	12				

Note: Shaft Options Series K92100

Add Suffix-S1 for #4-40 NC-2A Threaded Tip

Add Suffix-S2 for #2-56 NC-2A Threaded Tip

<b>Unipolar Drive</b>		
Max Pull-in Rate (Steps/Sec)	380	
Max Pull-out Rate (Steps/Sec)	650	
<b>Power Consumption:</b>	3.5 Watts	
<b>Insulation Resistance:</b>	20MΩ	
<b>Bearings:</b>	Radial Ball	
<b>Weight:</b>	1.5 oz. (42.5 gr.)	
<b>Operating Temp. Range:</b>	-20°C to 70°C	
<b>Storage Temp. Range:</b>	-40°C to 85°C	
<b>Coil Data</b>	-P1 (5Vdc)	-P2 (12Vdc)
<b>Resistance Per Phase:</b>	15Ω	84Ω
<b>Inductance Per Phase:</b>	5mH	29mH

For information or to place an order in North America: 1 (203) 271-6444 Europe: (44) 1276-691622 Asia: (65) 7474-888

# Dimensions: mm/in

## Series K92100

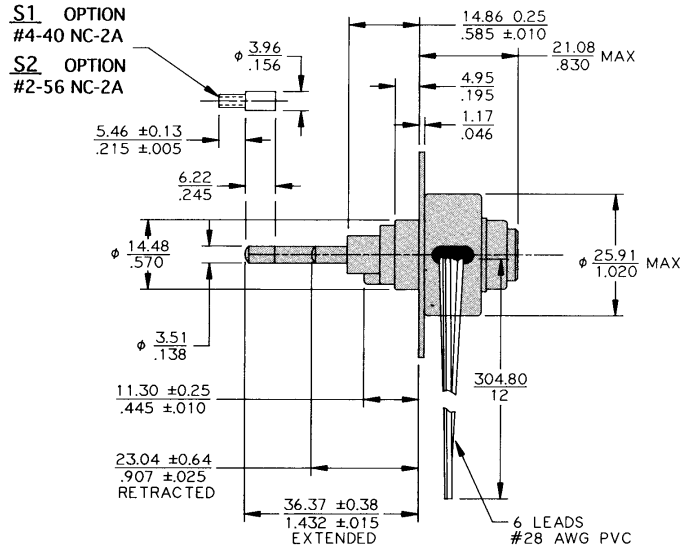
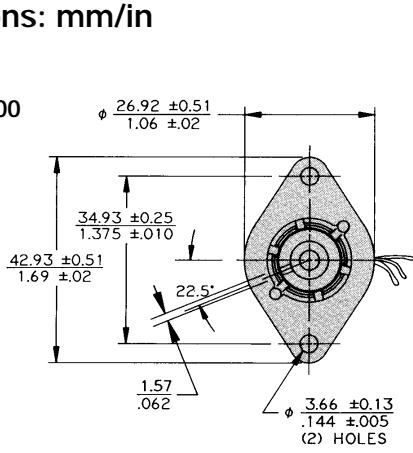

## Series L92100

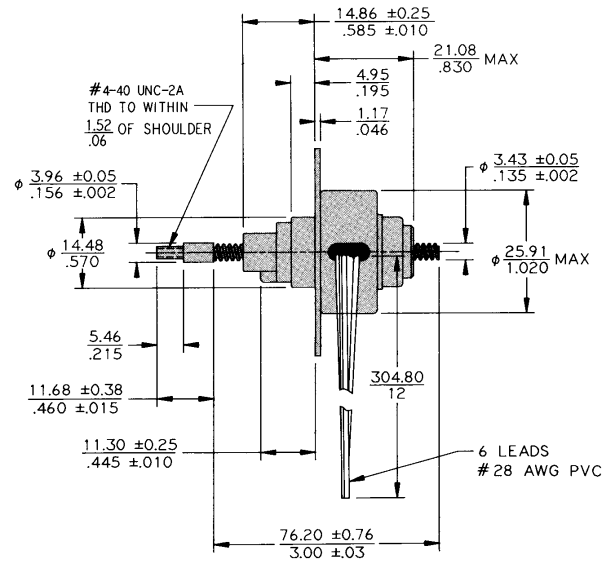
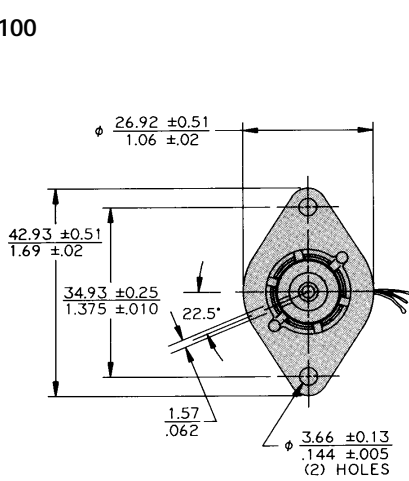

Typical Linear Pull-In Force vs. Linear Rate at 20°C

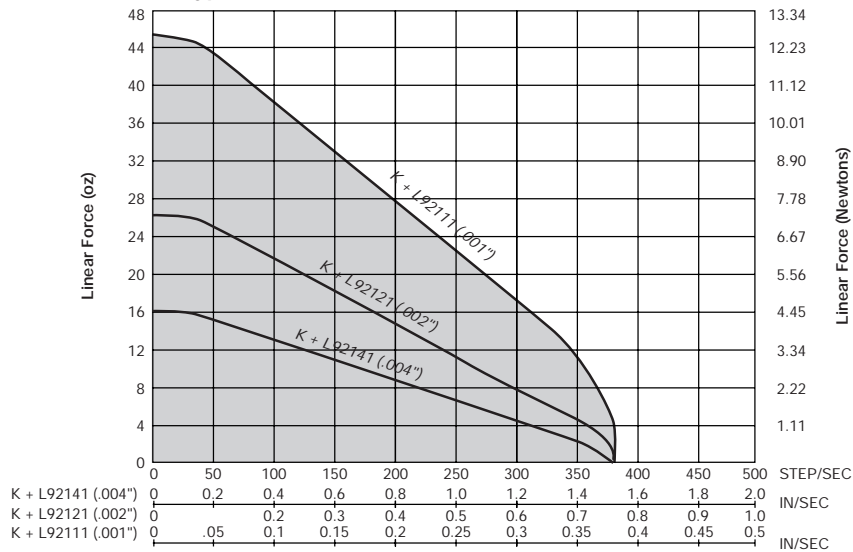

For information or to place an order in North America: 1 (203) 271-6444 Europe: (44) 1276-691622 Asia: (65) 7474-888

The specifications in this publication are believed to be accurate and reliable. However, it is the responsibility of the product user to determine the suitability of Thomson products for a specific application. While defective products will be replaced without charge if promptly returned, no liability is assumed beyond such replacement.



# Series K92200 & L92200 Digital Linear Actuators

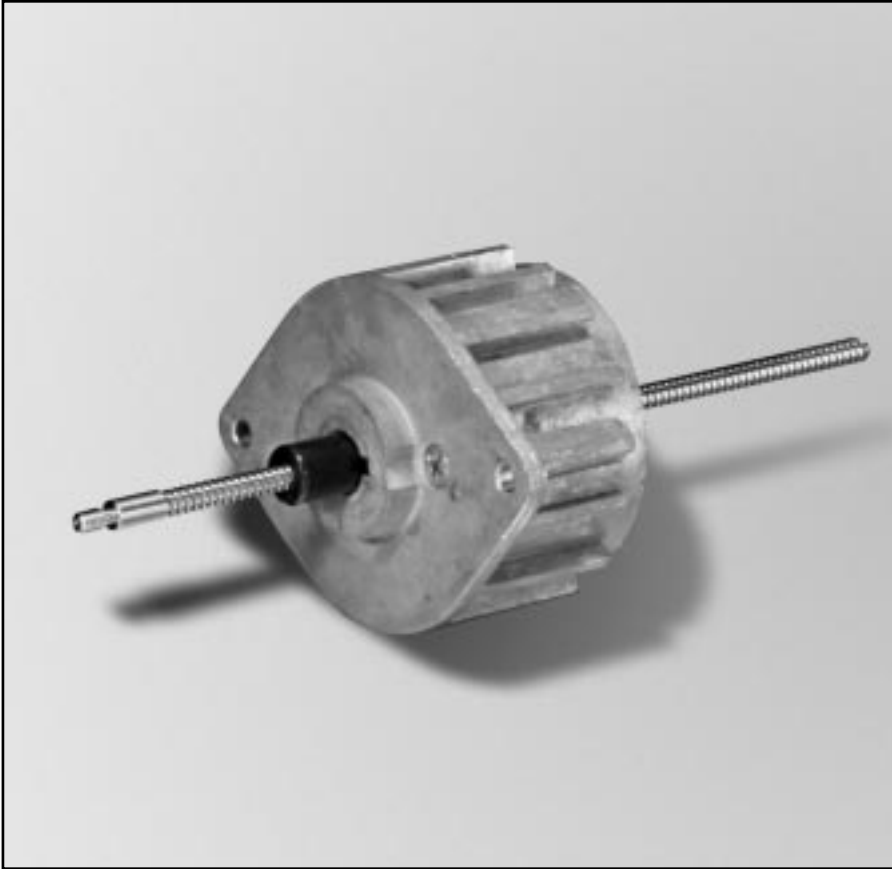

## Series 92200 Digital Linear Actuators

The Series 92200 bidirectional linear actuator is a stepper motor that has been modified by incorporating an internally threaded rotor and fitting it with a lead screw shaft. Energizing the unit's coils in proper sequence will cause the threaded shaft to move out of or back into the rotor in linear increments of .001", .002", or .003" per pulse. The actuator shaft will remain in position when power is removed.

Series 92200 is rated with a maximum linear force of 75 ounces. The actuator shaft has a maximum travel of 0.875" for the "K" unit and 2.5" for the "L" unit. The *Linear Force Graph* shows typical forces available vs. pulse rates. "K" units contain an integral anti-rotational shaft feature. "L" units require an external means of preventing shaft rotation.

Use this actuator wherever precise response and precision movements are essential. Typical applications include valve actuation and variable displacement pump regulation in process control situations and medical equipment. Unique step increment, force output or travel needs can be handled on a special basis.

Please supply us with complete specifications of your requirements.

## Specifications

Part Number	DC Operating Voltage	Maximum Travel	Linear Travel Per Step	Maximum Force	Minimum Holding Force (Unenergized)
K92211-P1	5	.875" (22.2mm)	.001" (.025mm)	75 oz (20.9N)	40 oz (11.1N)
K92211-P2	12				
L92211-P1	5	2.5" (63.5mm)			
L92211-P2	12				
K92221-P1	5	.875" (22.2mm)	.002" (.05mm)	55 oz (15.3N)	20 oz (5.6N)
K92221-P2	12				
L92221-P1	5	2.5" (63.5mm)			
L92221-P2	12				
K92231-P1	5	.875" (22.2mm)	.003" (.076mm)	32 oz (8.9N)	8 oz (2.2N)
K92231-P2	12				
L92231-P1	5	2.5" (63.5mm)			
L92231-P2	12				

Note: Part number without suffix will be supplied with #4-40 NC-2A Threaded  
Part number with suffix -S1 will be supplied with #2-56 NC-2A Threaded

<b>Unipolar Drive</b>		
Max Pull-in Rate (Steps/Sec)	425	
Max Pull-out Rate (Steps/Sec)	700	
<b>Power Consumption:</b>	5 Watts	
<b>Insulation Resistance:</b>	20 MΩ	
<b>Bearings:</b>	Radial Ball	
<b>Weight:</b>	7 oz. (198 gr.)	
<b>Operating Temp. Range:</b>	-20°C to 70°C	
<b>Storage Temp. Range:</b>	-40°C to 85°C	
<b>Coil Data</b>	-P1 (5Vdc)	-P2 (12Vdc)
<b>Resistance Per Phase:</b>	10Ω	58Ω
<b>Inductance Per Phase:</b>	5.2mH	30mH

For information or to place an order in North America: 1 (203) 271-6444 Europe: (44) 1276-691622 Asia: (65) 7474-888

# Dimensions: mm/inches

## Series K92200

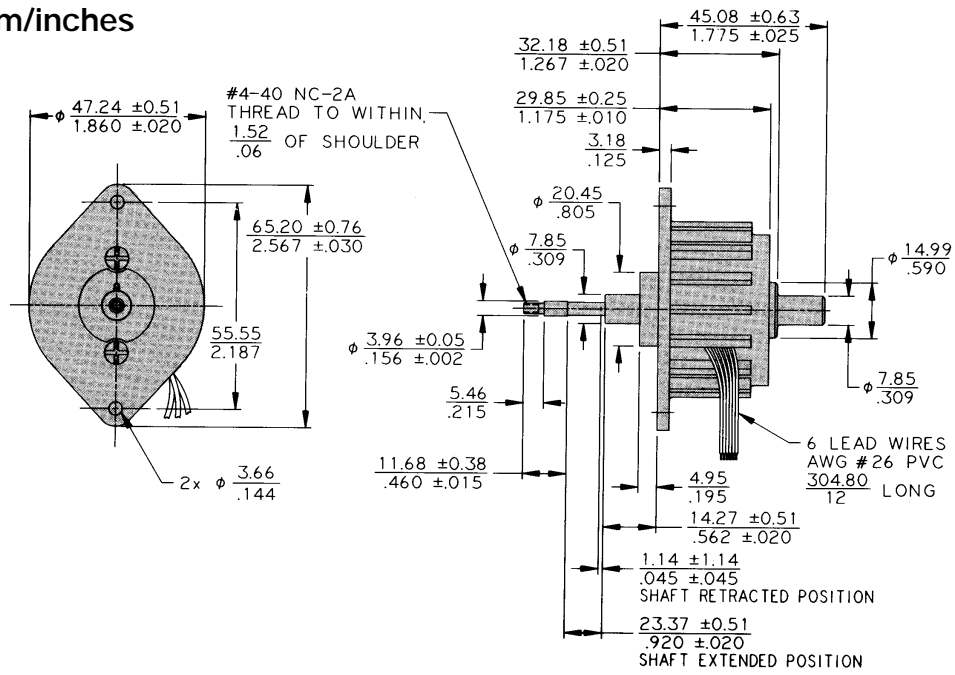

## Series L92200

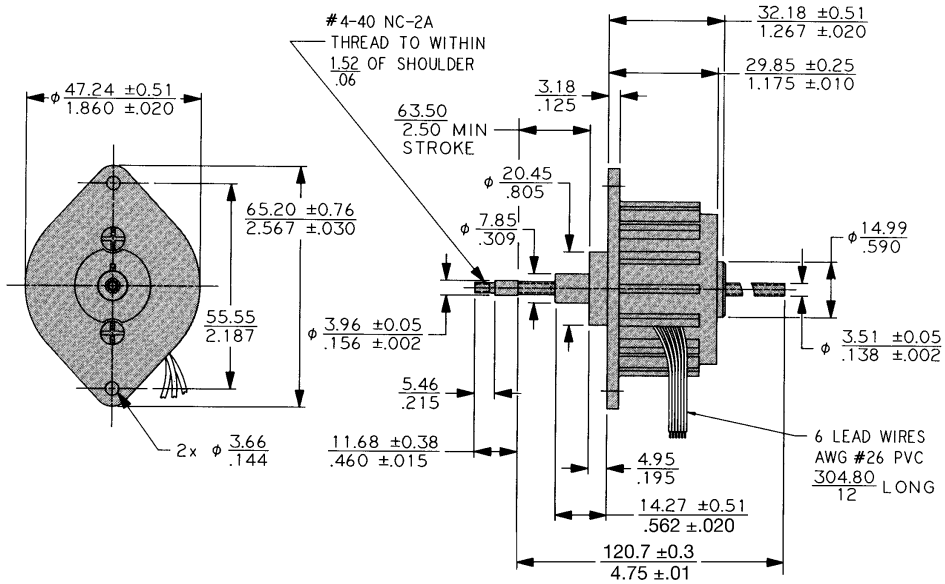

Typical Linear Pull-In Force vs. Linear Rate at 20°C

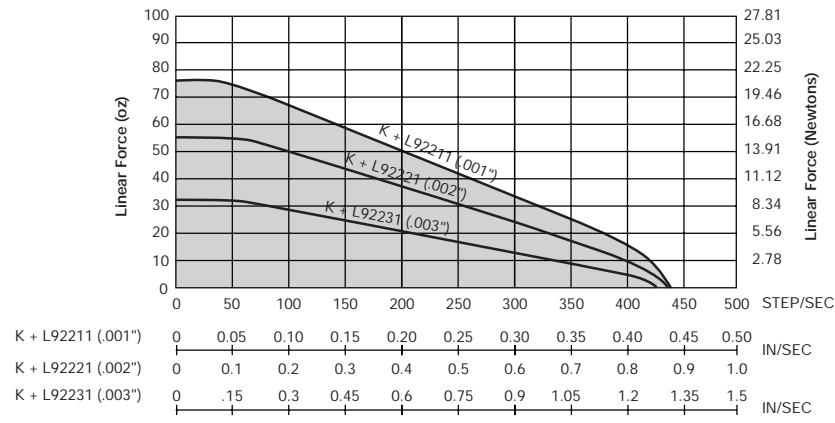

For information or to place an order in North America: 1 (203) 271-6444 Europe: (44) 1276-691622 Asia: (65) 7474-888

The specifications in this publication are believed to be accurate and reliable. However, it is the responsibility of the product user to determine the suitability of Thomson products for a specific application. While defective products will be replaced without charge if promptly returned, no liability is assumed beyond such replacement.



# Series L92400 Digital Linear Actuators

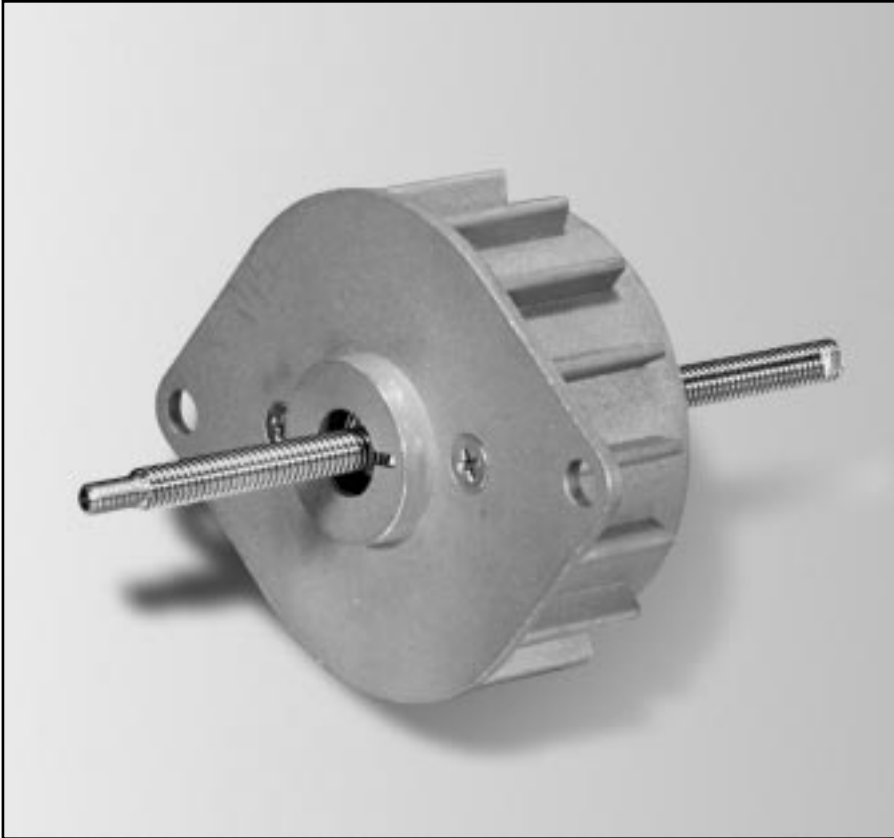

## Series 92400 Digital Linear Actuators

The Series 92400 bidirectional linear actuator is a stepper motor that has been modified by incorporating an internally threaded rotor and fitting it with a lead screw shaft. Energizing the unit's coils in proper sequence will cause the threaded shaft to move out of or back into the rotor in precise linear increments of .001" or .002" per pulse. The actuator shaft will remain in position when power is removed.

Series 92400 is rated with a maximum linear force of 20 pounds. The actuator shaft has a maximum travel of 3". This unit needs an external means for preventing shaft rotation. The *Linear Force Graph* charts typical forces available vs. pulse rates.

This actuator is ideal for exact response and precision movements. Typical applications include valve actuation and variable displacement pump regulation in process control situations and in medical equipment, and pneumatic valve control in air brake systems. Unique step increment, force output or travel needs can be handled on a special basis.

Please supply us with complete specifications of your requirements.

## Specifications

Part Number	DC Operating Voltage	Maximum Travel	Linear Travel Per Step	Maximum Force	Minimum Holding Force (Unenergized)
L92411-P1	5	3" (76.2mm)	.001" (.025mm)	20 lb (88N)	>20 lb (88N)
L92411-P2	12				
L92421-P1	5	3" (76.2mm)	.001" (.025mm)	16 lb (71N)	>16 lb (71N)
L92421-P2	12				

<b>Unipolar Drive</b>		
Max Pull-in Rate (Steps/Sec)	275	
Max Pull-out Rate (Steps/Sec)	450	
<b>Power Consumption:</b>	12Watts	
<b>Insulation Resistance:</b>	20 MΩ	
<b>Bearings:</b>	Radial Ball	
<b>Weight:</b>	1 lb (0.45 Kilo)	
<b>Operating Temp. Range:</b>	-20°C to 70°C	
<b>Storage Temp. Range:</b>	-40°C to 85°C	
<b>Coil Data</b>	-P1 (5Vdc)	-P2 (12Vdc)
<b>Resistance Per Phase:</b>	4.3Ω	25Ω
<b>Inductance Per Phase:</b>	5mH	25mH

For information or to place an order in North America: 1 (203) 271-6444 Europe: (44) 1276-691622 Asia: (65) 7474-888



# Dimensions: mm/in

## Series L92400

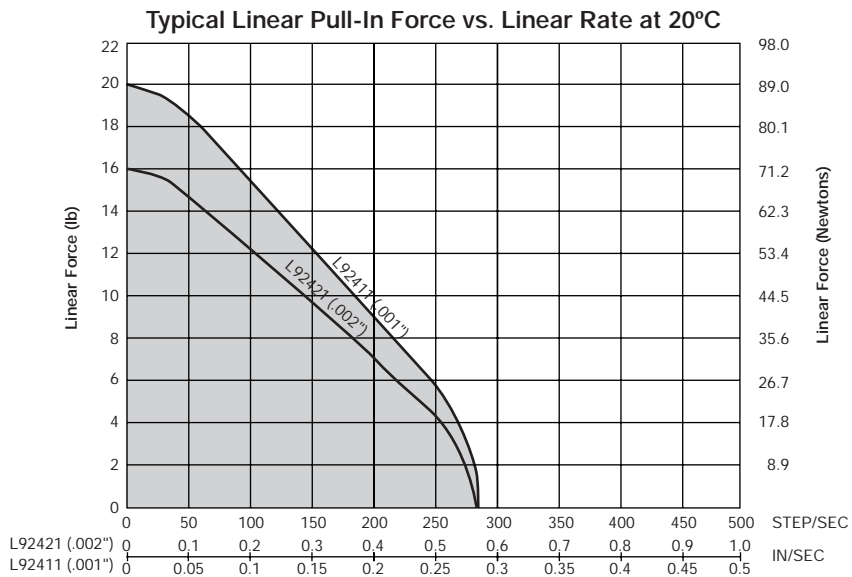
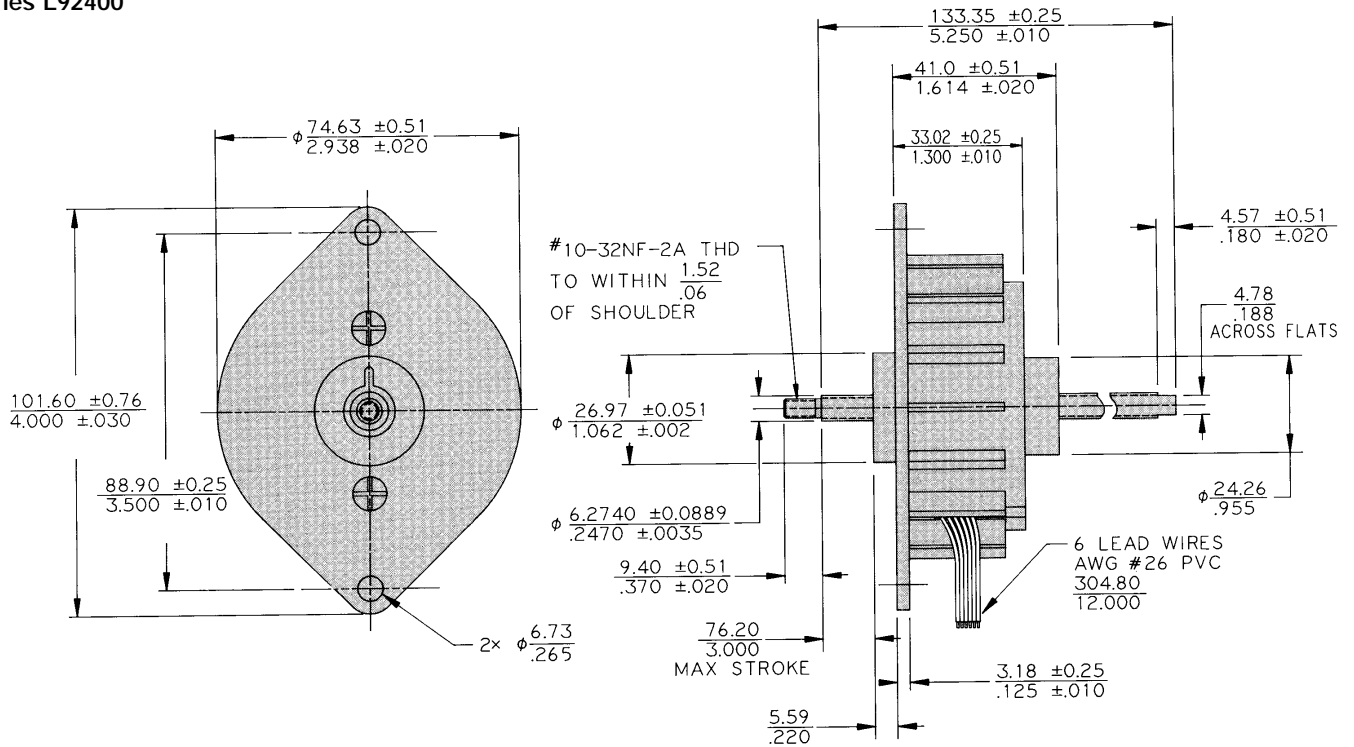

For information or to place an order in North America: 1 (203) 271-6444 Europe: (44) 1276-691622 Asia: (65) 7474-888

The specifications in this publication are believed to be accurate and reliable. However, it is the responsibility of the product user to determine the suitability of Thomson products for a specific application. While defective products will be replaced without charge if promptly returned, no liability is assumed beyond such replacement.



# New! Brushless DC Motors Coming Soon

In 1999, Thomson Airpax Mechatronics will be launching a state-of-the-art family of Brushless DC (BLDC) Motors designed for maximum efficiency and speed control. These motors feature permanent magnet rotors, laminated stators, and spindles with ball bearings. They are available with or without on-board electronics.

- Efficiency maximized by integrating speed control through on-board electronics
- Available in 58 mm and 98 mm diameter frame sizes
- Outside rotor construction provides low instantaneous speed variation (ISV) and minimizes impact of load variation
- Low electromagnetic interference (EMI)
- Low audible noise
- Low temperature rise
- 3 – 5 times the life of conventional brush type DC motors

Thomson Airpax Mechatronics BLDC motors are ideally suited for applications such as:

- |                            |  |                          |
|----------------------------|--|--------------------------|
| ■ Actuators/Linear Systems | ■ Computer Peripherals                   | ■ Medical Equipment      |
| ■ Aircraft                 | ■ Copiers and Scanners                   | ■ Pumps                  |
| ■ Appliances               | ■ HVAC (Damper Control and Air Movement) | ■ Robotics               |
| ■ Automotive               | ■ Mail Sorters                           | ■ Scientific Instruments |
| ■ Business Machines        |  | ■ Servo Control Systems  |

*Call or E-Mail and discuss your application with an expert*

North America: 1 (203) 271-6444  
motorinfo@snet.net

Europe: (44) 1276-691622  
info@tammail.com

Asia: (65) 7474-888  
airpax@tamsales.com.sg



# Motion Control Solutions From Thomson Industries



## TMC-2000 Motion Controller

- High performance, stand alone, multi axis servo and stepper motor controller
- Performs point to point motion, linear and circular interpolation, contouring, electronic gearing, electronic cam, and jogging
- Powerful yet simple instruction set supports multitasking, user variables and arrays, arithmetic and logic functions, position latch, event triggers, error handling and more.
- Servo Setup Kit\* software for Windows® provides communications, program editing, tuning and diagnostics
- All optoisolated I/O



## AXI-PAK\* Complete Servo Axis Packages

- A complete servo axis that operates either with a motion controller or as a smart stand alone drive
- Includes a matched BLX brushless motor, OMNIDRIVE\* digital servo drive, professionally molded cables, OMNI LINK\* setup software, and documentation for a fast and worry free installation
- The latest technology and most rugged design for a high performance industrial quality turn key motion control solution



## OMNIDRIVE Digital Servo Drives

- Fully digital "smart" brushless servo amplifier with integrated power supply
- Configurable for analog input, step and direction, serial link, encoder follower, electronic gearing
- Indexing option for stand alone positioning capabilities
- Available in 0.5, 1, 2, 3, 7.5, and 15 kW continuous power ratings
- Included OMNI LINK setup and diagnostic software

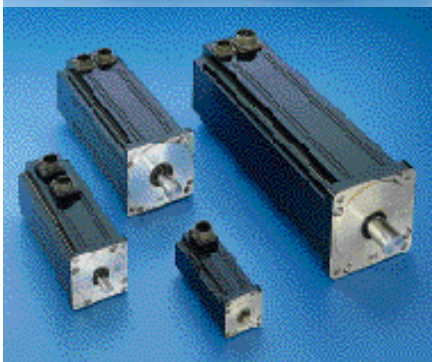

## BLX Brushless Servo Motors

- Superior magnetic and thermal design gives exceptional performance and the highest torque per frame size
- Standard IP65 sealing, MS style fluid tight connectors, oversize bearings, and thermal switch ensure a long and worry free service life
- A variety of frame sizes and winding configurations are available to suit your precise application needs
- Internal bearing mounted commutating encoder provides precision and reliability
- Available with planetary gearheads and internal brakes

*Call or E-mail and discuss your application with an expert.*

Phone: 1-800-554-8466 E-mail: [motion@thomsonmail.com](mailto:motion@thomsonmail.com) Website: [www.thomsoncontrol.com](http://www.thomsoncontrol.com)

\*Trademark of Thomson Industries, Inc. THOMSON is registered in the U.S. Patent and Trademark Office and in other countries. The specifications in this publication are believed to be accurate and reliable. However, it is the responsibility of the product user to determine the suitability of Thomson products for a specific application. While defective products will be replaced without charge if promptly returned, no liability is assumed beyond such replacement. Windows is a registered trademark of Microsoft Corporation.

# BRUSHLESS DC MOTORS

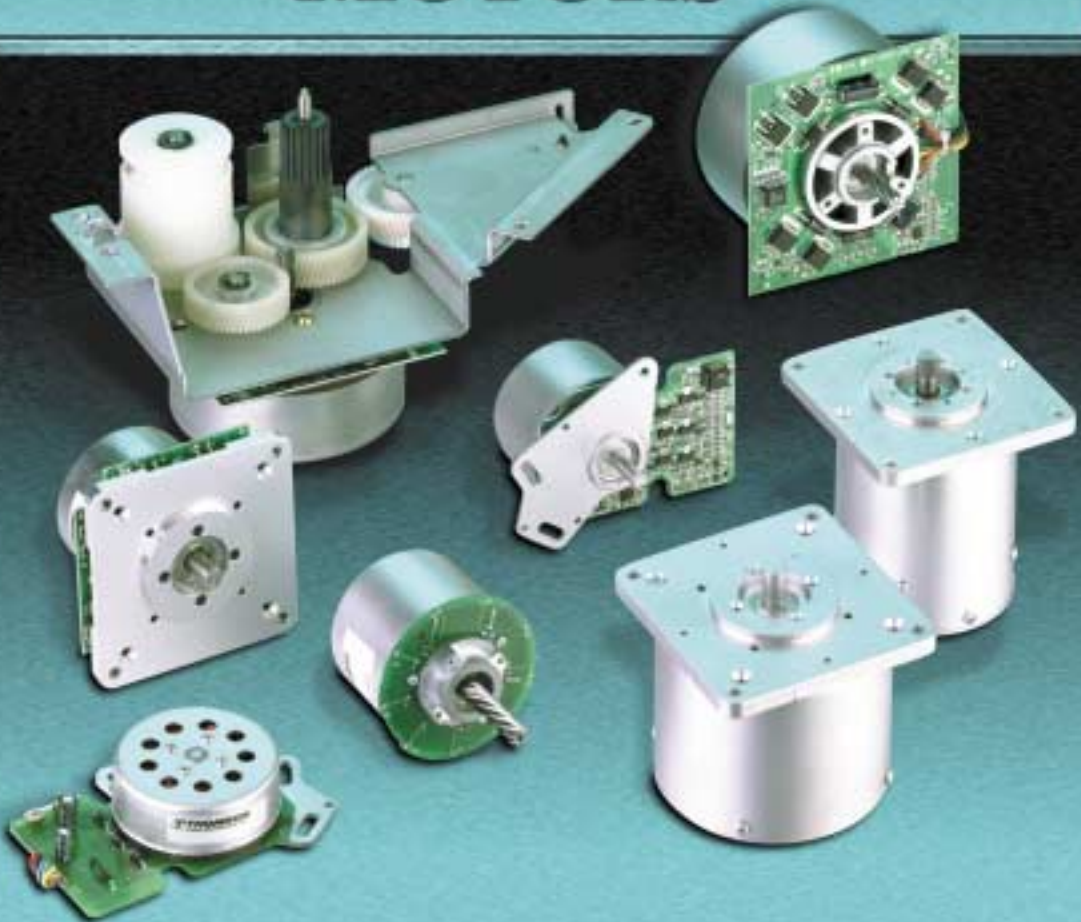

## B E N E F I T S

- Up to 5x longer life than conventional DC brush motors
- Low EMI – satisfies U.S. FCC and European (CISPR 22-P) standards
- Low RFI • Cooler operating temperature - 23°C vs. 70°C
- Excellent speed stability • Low audible noise

**THOMSON AIRPAX**  
**MECHATRONICS**

*All Thomson Industries Manufacturing Locations are  
ISO 9000 Certified and Automotive Facilities  
Operate to QS-9000 Standards  
Three-time Winner General Motors Supplier of the Year*

**ISO 9000**





58mm with driver

58mm Hall Effect

98mm with driver

NEMA 58mm

Custom Geartrain

## UNIQUE FEATURES

The new THOMSON AIRPAX MECHATRONICS three-phase MOSFET drive using surface mounted components provides:

- 30% MORE PERFORMANCE** Pulse Width Modulation (PWM) drive eliminates the need for external controllers. 30% more efficient than similar standard packages.
- 20% LOWER DISTORTION** Onboard proportion tachometer minimizes distortion with proprietary circuitry.
- 33% SMALLER PACKAGE** Thomson's Brushless DC motors achieve their performance with a package size that is only 2/3 the size of standard Brushless DC motors.
- 20% + LOWER POWER CONSUMPTION** Thomson Airpax Mechatronics' combination of design features results in lower overall power usage than other Brushless DC motors and external controllers of equivalent size.

## MOTOR FEATURE

MOTOR SIZE	58mm	98mm
Power range	60W	110W
Operating speed normal	5,000 RPM	3,000 RPM
Operating speed with dynamic balancing	10,000 RPM	8,000 RPM
Proprietary circuitry to minimize jitter	✓	✓
Dynamic braking	✓	
On board current limiting	✓	✓

For information or engineering assistance, contact the Thomson Airpax Mechatronics Motor Hotline:

Call (toll free): 1-877-9AIRPAX (1-877-924-7729)

Fax: 1-877-4AIRPAX (1-877-424-7729)

For worldwide assistance, call in Europe: (44) 1252 516051; in Asia: (65) 7474-888

E-mail: [motorinfo@snet.net](mailto:motorinfo@snet.net)

Web: [www.thomsonindustries.com](http://www.thomsonindustries.com)

# 58MD046 and 58MD055 Series Brushless DC Motors

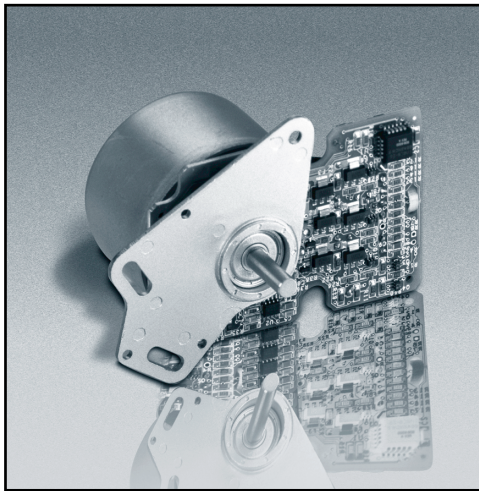

## Overall Dimensions

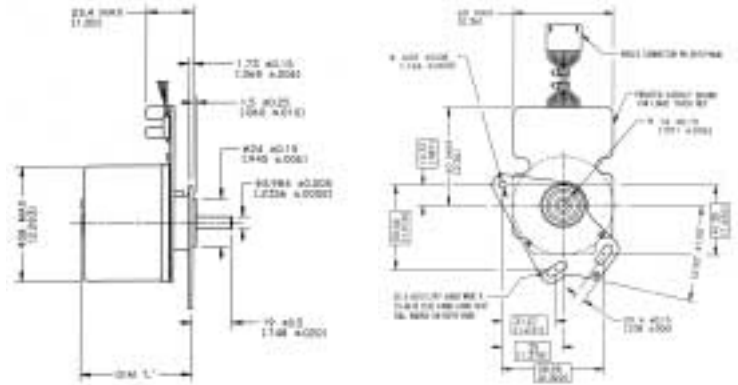

For motor length dimensions, see chart below

- **Electrically quiet.** Lower EMI (Electromagnetic Interference) transmitted. Levels of 25 dba are typical, making these motors ideal for applications that must satisfy U.S. FCC and European (CISPR 22-P) standards.
- **Better speed stability.** Lower ISV (Instantaneous Speed Variation). Due to the outside spin rotor, a higher degree of mechanical damping is achieved. They are ideal for applications where constant speed is critical.
- **Higher application versatility.** Onboard PWM (pulse width modulation) capability supports a multitude of application needs with a single motor and winding. They can be run open or closed loop.
- <sup>a</sup> **Lower encoder distortion.** Critical to applications of lower speeds (100 to 300 RPM) where closed loop constant velocity is required.
- **Lower deceleration.** Motor's control circuitry provides electronically controlled on board dynamic braking. This feature is critical to applications where a quick stop must be maintained.
- **Cooler Operating Temperature.** Lower temperature rise (less than 40°C). This combined with the designed insulation system of Class B (130° C) allows the use of the motors in environments up to 85° C.

Specifications at a Glance		
Part Number	58MD046024-1	58MD0055036-1
Operating Voltage (V)	24	36
Motor Length (mm)	46	55
No Load Speed (rpm)	2000	1800
Rated Output (W)	14	17
Bearings	Ball	Ball
Direction of Rotation	Reversible	Reversible
Rotor Inertia (kgm <sup>2</sup> )	9.50 x 10 <sup>-5</sup>	12.10 x 10 <sup>-5</sup>
Number of Phases	3-Y	3-Y
Number of Poles	12	12
Terminal Resistance (Ohms)	2.35	6.15
Terminal Inductance (mH)	4.32	11.2
Torque Constant (Nm/Amp)	0.110	0.165



<sup>a</sup>Trademark of Thomson Industries, Inc. THOMSON is registered in the U.S. Patent and Trademark Office and in other countries.

## 58MD046024-1 Torque Speed Curves

Motor Performance at 100% PWM

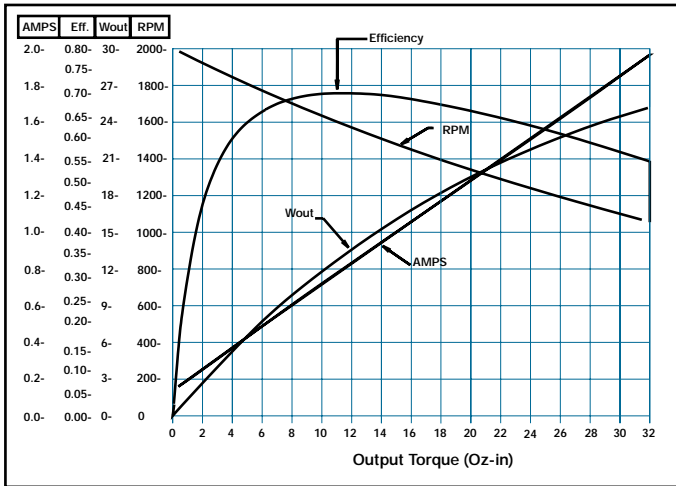

Motor Performance at 50% PWM

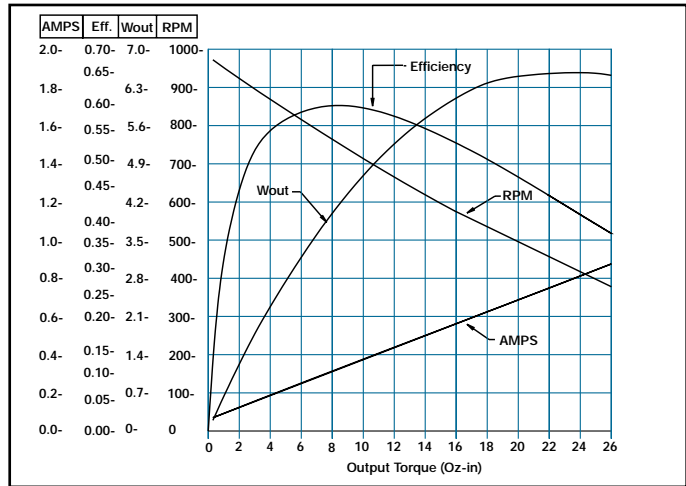

## 58MD055036-1 Torque Speed Curves

Motor Performance at 100% PWM

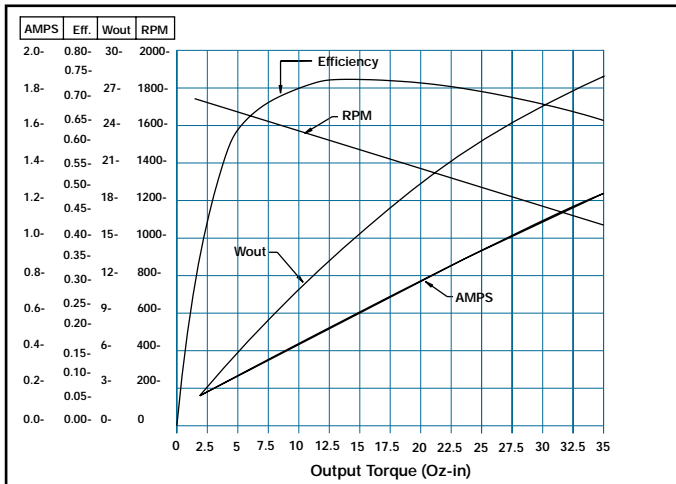

Motor Performance at 50% PWM

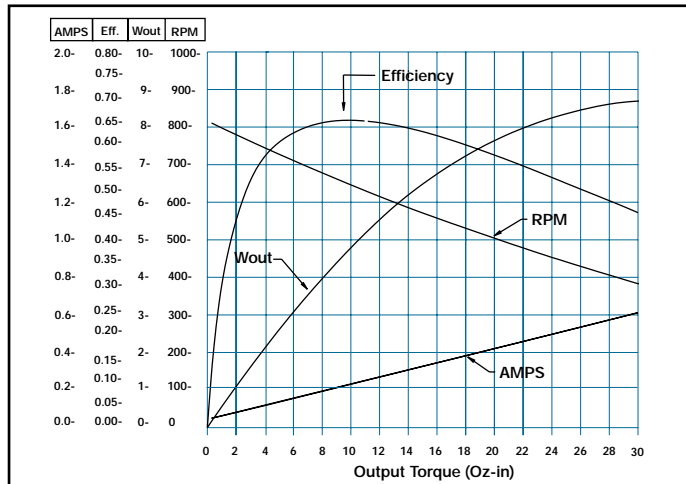

**Custom Design Capability.** Let THOMSON AIRPAX MECHATRONICS design the specific winding and torque constant that best fulfills your application in terms of efficiency. This will result in a motor of a frame size requiring the lowest current necessary to perform the task. This advantage may enable a smaller power supply to be used.

### Motor Connections

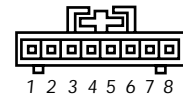

Pin	Color	Feature	Connection
1	Red	Motor Voltage	+ Motor Voltage
2	Black	Motor Ground	Motor Ground
3	Blue	5V Supply	4.75 - 5.25 VDC
4	Green	5V Ground	Logic Ground
5	Yellow	Enable	Active Ground
6	Purple	Direction	Active Ground
7	Orange	PWM Input	Ground for Full Speed
8	Brown	Tach Output	5V Square Wave

It is the responsibility of the product user to determine the suitability of Thomson components for a specific application. Defective products will be replaced without charge if promptly returned. No liability will be assumed beyond such replacement.

\*Trademark of Thomson Industries, Inc. THOMSON is registered in the U.S. Patent and Trademark Office and in other countries.



**Controller Block Diagram**

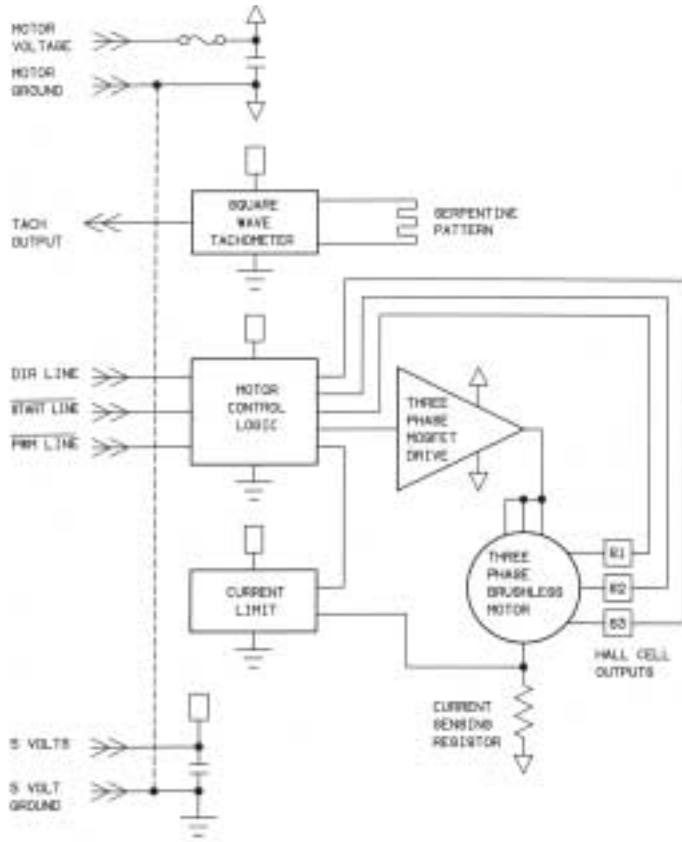

**Part Numbering System**

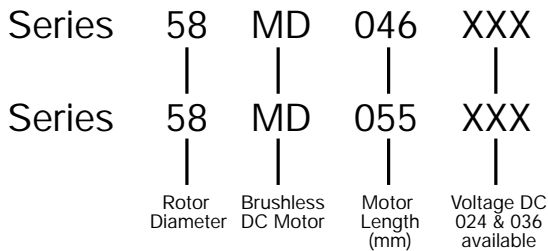

**Controller Features**

**Enable Input/ Braking Feature**

Connecting Pin 5 to ground enables motor operation. With Pin 5 ungrounded, the motor stops and enters a dynamic braking mode.

**Direction Input**

Normal motor rotation direction is clockwise when viewed from shaft output end. With Pin 6 grounded, motor will run counterclockwise when viewed from shaft output end.

**PWM Input**

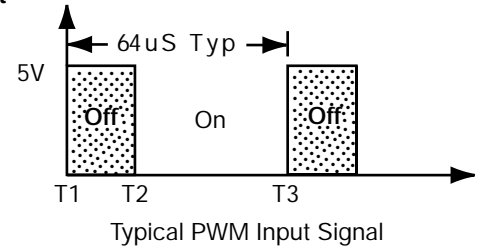

Full speed operation is achieved by grounding Pin 7 when Enable (Pin 5) is grounded. Motor output power (speed) is proportional to the inverse of the duty cycle of this Pulse Width Modulated signal. Through the motor circuitry, motor is 'on' only during the low state. In the above diagram, from T1 to T2 motor is 'off' and from T2 to T3 motor is 'on'. PWM limits the motor output power as expressed by the following equation:

$$\% \text{ Total Output Power} = \{T3 / (T3-T2)\} \times 100$$

**Tachometer Output**

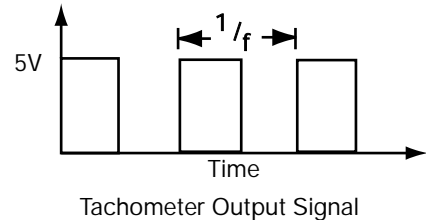

Pin 8 provides a 45 pulse per revolution 5V square wave representative of motor speed. Motor RPM is expressed as a multiple of the tachometer signal frequency as follows:

$$\text{RPM} = 1.33 \times f$$





2 Channel Drive  
Port Washington, NY 11050 USA

*All Thomson Industries Manufacturing Locations are  
ISO 9000 Certified and Automotive Facilities  
Operate to QS-9000 Standards  
Three-time Winner General Motors Supplier of the Year*

**ISO 9000**

PRESORTED  
STANDARD  
**US POSTAGE PAID**  
THOMSON  
INDUSTRIES, INC.

# Thomson Airpax Mechatronics Brushless DC Motors



## FEATURES:

- Up to 5x longer life than conventional DC brush motors
- Low EMI/RFI - satisfies U.S. FCC and European (CISPR 22-P) standards
- Low temperature rise - 40°C vs. conventional 70°C
- Better speed stability
- Low audible noise - 30dba
- Low starting speed - as slow as 100 RPM

\*Trademark of Thomson Industries, Inc. THOMSON is registered in the U.S. Patent and Trademark Office and in other countries. The specifications in this publication are believed to be accurate and reliable. However, it is the responsibility of the product user to determine the suitability of Thomson products for a specific application. While defective products will be replaced without charge if promptly returned, no liability is assumed beyond such replacement. ©2000 Thomson Industries, Inc. Printed in the U.S.A. Challenge 10K 3-9-00 CP/HAP 9909-09.qxd 12-03-000-6502

For Technical Assistance or to place an order:

### DIVISIONAL HEADQUARTERS

THOMSON AIRPAX MECHATRONICS LLC  
7 McKee Place  
Cheshire, CT 06410 USA  
E-mail: motorinfo@snet.net  
Phone: 1 (877) 9-AIRPAX (924-7729)  
Fax: 1 (877) 4-AIRPAX (424-7729)

### EUROPE

THOMSON AIRPAX MECHATRONICS (UK) LIMITED  
9 Farnborough Business Centre  
Eelmoor Road, Farnborough  
Hants GU14 7XA UK  
E-mail: info@tammail.com  
Phone: + (44) 1252-516051  
Fax: + (44) 1252 516058

### ASIA

THOMSON AIRPAX MECHATRONICS PTE LTD.  
Block 3015A, Ubi Road 1  
#07-08 Kampong Ubi  
Industrial Estate  
Singapore 408705  
E-mail: airpax@tamsales.com.sg  
Phone: (65) 7474-888  
Fax: (65) 7435-686

### CORPORATE HEADQUARTERS

THOMSON INDUSTRIES, INC.  
2 Channel Drive  
Port Washington, NY 11050 USA  
Web: www.thomsonindustries.com  
E-mail: litrequest@thomsonmail.com  
Phone: 1-800-554-THOMSON  
Fax: 1-800-445-0329

# 98MD044 and 98MD048 Series Brushless DC Motors

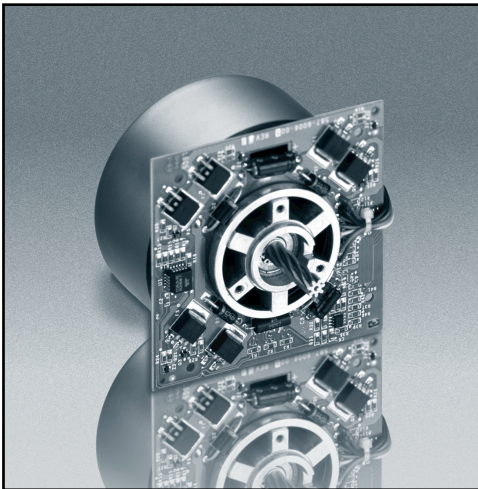

## Overall Dimensions

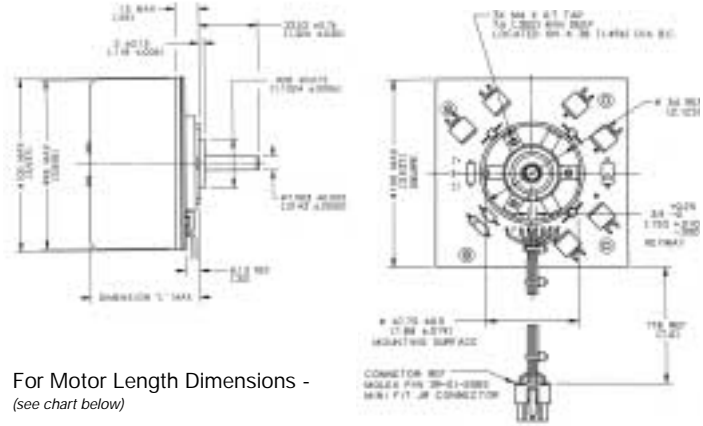

- **Electrically quiet.** Lower EMI (Electromagnetic Interference) transmitted. Levels of 30 dba are typical, making these motors ideal for applications that must satisfy U.S. FCC and European (CISPR 22-P) standards.
- **Better speed stability.** Lower ISV (Instantaneous Speed Variation). Due to the outside spin rotor, a higher degree of mechanical damping is achieved. They are ideal for applications where constant speed is critical.
- **Higher application versatility.** Onboard PWM (pulse width modulation) capability supports a multitude of application needs with a single motor and winding. They can be run open or closed loop
- **Lower encoder distortion.** Critical to applications of lower speeds (100 to 300 RPM) where closed loop constant velocity is required
- **Cooler Operating Temperature.** Lower temperature rise (less than 40° C). This combined with the designed insulation system of Class B (130° C) allows the use of the motors in environments up to 85° C.

## Specifications at a Glance

Part Number	98MD0044036-1	98MD048036-1
Operating Voltage (V)	36	36
Motor Length (mm)	43.5	48
No Load Speed (rpm)	1800	2800
Rated Output (W)	26	35
Bearings	Ball	Ball
Direction of Rotation	Reversible	Reversible
Rotor Inertia (kgm <sup>2</sup> )	64.0 x 10 <sup>-5</sup>	75.0 x 10 <sup>-5</sup>
Number of Phases	3-Y	3-Y
Number of Poles	12	12
Output Tachometer (pulse/rev)	50	50
Terminal Resistance (Ohms)	1.37	0.36
Terminal Inductance (mH)	7.2	2.2
Torque Constant (Nm/Amp)	0.182	0.127

## 98MD044036-1 Torque Speed Curves

Motor Performance at 100% PWM

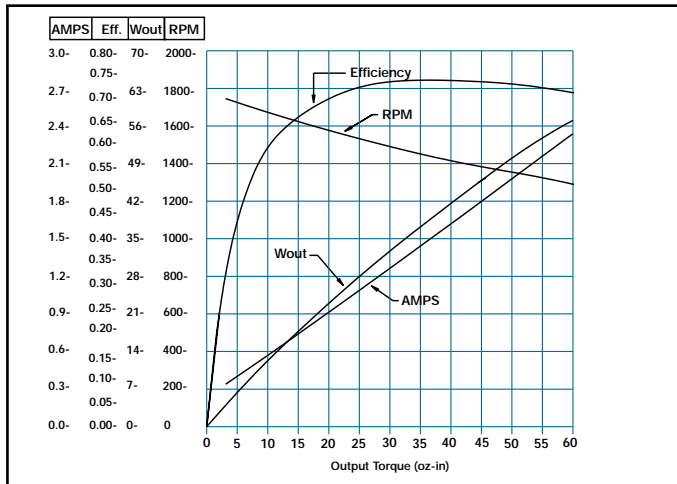

Motor Performance at 50% PWM

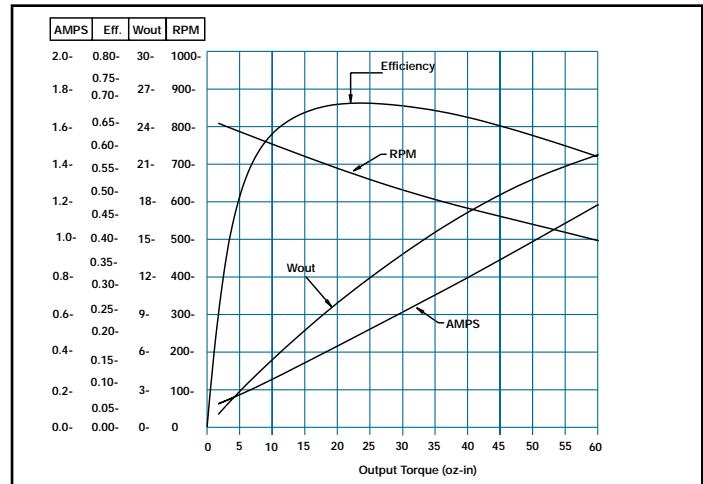

## 98MD048036-1 Torque Speed Curves

Motor Performance at 100% PWM

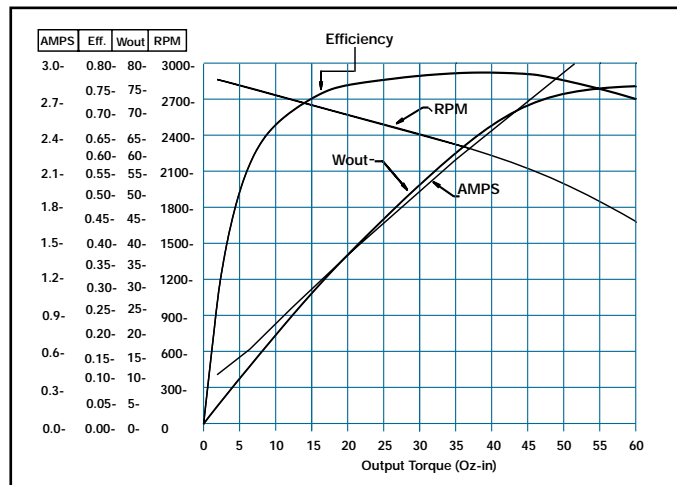

Motor Performance at 50% PWM

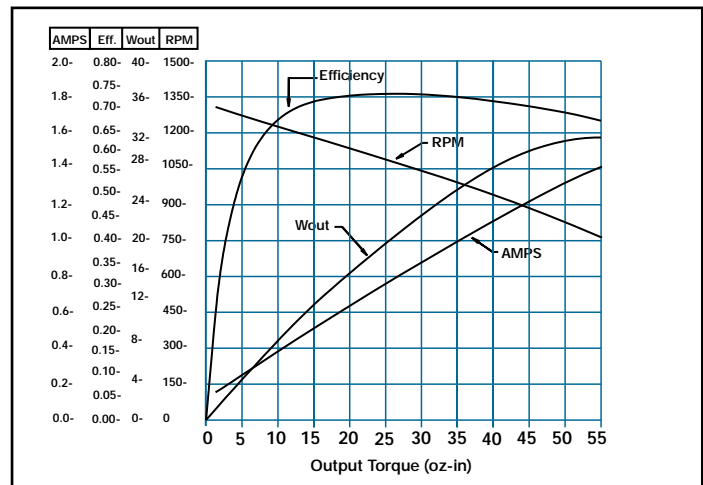

**Custom Design Capability.** Let THOMSON AIRPAX MECHATRONICS design the specific winding and torque constant that best fulfills your application in terms of efficiency. This will result in a motor of a frame size requiring the lowest current necessary to perform the task. This advantage may enable a smaller power supply to be used.

### Motor Connections

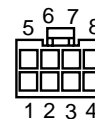

Pin	Color	Feature	Connection
1	Red	Motor Voltage	+ Motor Voltage
2	Black	Motor Ground	Motor Ground
3	Blue	5V Supply	4.75 - 5.25 VDC
4	Green	5V Ground	Logic Ground
5	Yellow	Enable	Active Ground
6	Purple	Direction	Active Ground
7	Orange	PWM Input	Ground for Full Speed
8	Brown	Tach Output	5V Square Wave

It is the responsibility of the product user to determine the suitability of Thomson components for a specific application. Defective products will be replaced without charge if promptly returned. No liability will be assumed beyond such replacement.

\*Trademark of Thomson Industries, Inc. THOMSON is registered in the U.S. Patent and Trademark Office and in other countries.



### Controller Block Diagram

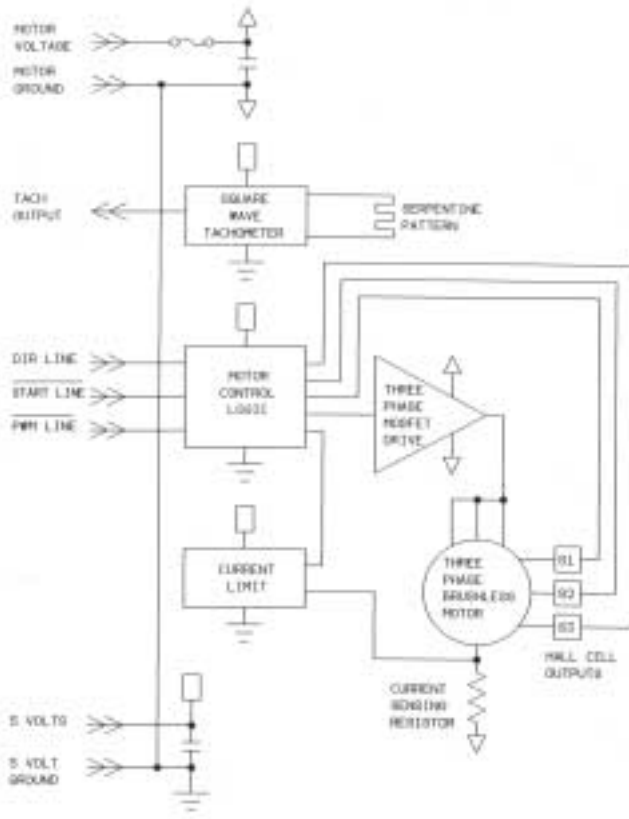

### Controller Features

#### Enable Input

Connecting Pin 5 to ground enables motor operation.

#### Direction Input

Normal motor rotation direction is clockwise when viewed from shaft output end. With Pin 6 grounded, motor will run counterclockwise when viewed from shaft output end.

#### PWM Input

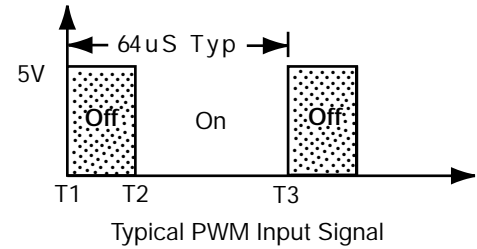

Full speed operation is achieved by grounding Pin 7 when Enable (Pin 5) is grounded. Motor output power (speed) is proportional to the inverse of the duty cycle of this Pulse Width Modulated signal. Through the motor circuitry, motor is 'on' only during the low state. In the above diagram, from T1 to T2 motor is 'off' and from T2 to T3 motor is 'on'. PWM limits the motor output power as expressed by the following equation:

$$\% \text{ Total Output Power} = \{T3 / (T3 - T2)\} 100$$

### Part Numbering System

Series	98	MD	044	XXX
Series	98	MD	048	XXX
	Rotor Diameter	Brushless DC Motor	Nominal Operating Voltage	Motor Height from Mounting Surface

#### Tachometer Output

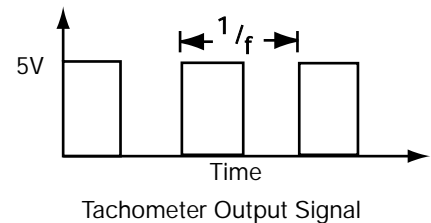

Pin 8 provides a 50 pulse per revolution 5V square wave representative of motor speed. Motor RPM is expressed as a multiple of the tachometer signal frequency as follows:

$$\text{RPM} = 1.2 \times f$$



2 Channel Drive  
Port Washington, NY 11050 USA

*All Thomson Industries Manufacturing Locations are  
ISO 9000 Certified and Automotive Facilities  
Operate to QS-9000 Standards  
Three-time Winner General Motors Supplier of the Year*

**ISO 9000**

PRESORTED  
STANDARD  
**US POSTAGE PAID**  
THOMSON  
INDUSTRIES, INC.

## Thomson Airpax Mechatronics Brushless DC Motors



### FEATURES:

- Up to 5x longer life than conventional DC brush motors
- Low EMI/RFI - satisfies U.S. FCC and European CISPR 22-P standards
- Low temperature rise - 30°C vs. conventional 70°C
- Better speed stability
- Low audible noise - 55dba
- Low starting speed - as low as 100 RPM

\*Trademark of Thomson Industries, Inc. THOMSON is registered in the U.S. Patent and Trademark Office and in other countries. The specifications in this publication are believed to be accurate and reliable. However, it is the responsibility of the product user to determine the suitability of Thomson products for a specific application. While defective products will be replaced without charge if promptly returned, no liability is assumed beyond such replacement. ©2000 Thomson Industries, Inc. Printed in the U.S.A. Challenge 10K 3-3-00 CP/HAP 9909-08.qxd 12-03-000-6501

For technical assistance or to place an order:

#### DIVISIONAL HEADQUARTERS

THOMSON AIRPAX MECHATRONICS LLC  
7 McKee Place  
Cheshire, CT 06410 USA  
E-mail: motorinfo@snet.net  
Phone: 1 (877) 9-AIRPAX (924-7729)  
Fax: 1 (877) 4-AIRPAX (424-7729)

#### EUROPE

THOMSON AIRPAX MECHATRONICS (UK) LIMITED  
9 Farnborough Business Centre  
Eelmoor Road, Farnborough  
Hants GU14 7XA, UK  
E-mail: info@tammail.com  
Phone: + (44) 1252-516051  
Fax: + (44) 1252 516058

#### ASIA

THOMSON AIRPAX MECHATRONICS PTE LTD.  
Block 3015A, Ubi Road 1  
#07-08 Kampong Ubi  
Industrial Estate  
Singapore 408705  
E-mail: airpax@tamsales.com.sg  
Phone: (65) 7474-888  
Fax: (65) 7435-686

#### CORPORATE HEADQUARTERS

THOMSON INDUSTRIES, INC.  
2 Channel Drive  
Port Washington, NY 11050 USA  
E-mail: litrequest@thomsonmail.com  
Phone: 1-800-554-THOMSON  
Fax: 1-800-445-0329  
Web: www.thomsonindustries.com

# 98MD053 and 98MD062 Series Brushless DC Motors

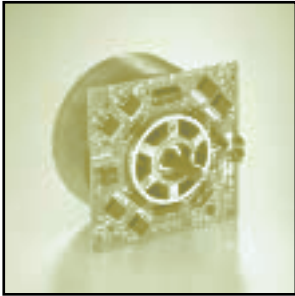
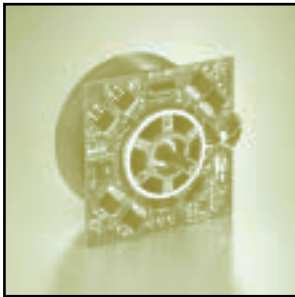

## Overall Dimensions

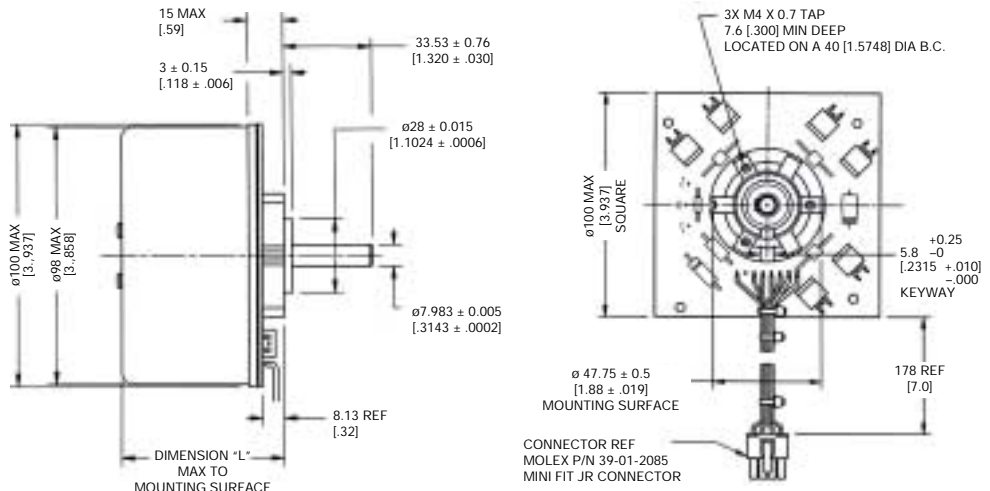

For Motor Length Dimensions -  
(see chart below)

- **Electrically quiet.** Lower EMI (Electromagnetic Interference) transmitted. Levels of 30 dba are typical, making these motors ideal for applications that must satisfy U.S. FCC and European (CISPR 22-P) standards.
- **Better speed stability.** Lower ISV (Instantaneous Speed Variation). Due to the outside spin rotor, a higher degree of mechanical damping is achieved. They are ideal for applications where constant speed is critical.
- **Higher application versatility.** Onboard PWM (pulse width modulation) capability supports a multitude of application needs with a single motor and winding. They can be run open or closed loop.
- **Lower encoder distortion.** Critical to applications of lower speeds (100 to 300 RPM) where closed loop constant velocity is required.
- **Cooler Operating Temperature.** Lower temperature rise (less than 40° C). This combined with the designed insulation system of Class B (130° C) allows the use of the motors in environments up to 85° C.

## Specifications at a Glance

Part Number	98MD053036-1	98MD062036-1
Operating Voltage (V)	36	36
Motor Length (mm)	52.5	62
No Load Speed (rpm)	2000	3000
Rated Output (W)	45	65
Bearings	Ball	Ball
Direction of Rotation	Reversible	Reversible
Rotor Inertia (kgm <sup>2</sup> )	83.50x10 <sup>-5</sup>	104.9x10 <sup>-5</sup>
Number of Phases	3-Y	3-Y
Number of Poles	12	12
Output Tachometer (pulse/rev)	50	50
Terminal Resistance (Ohms)	0.62	0.23
Terminal Inductance (mH)	3.9	1.17
Torque Constant (Nm/Amp)	0.171	0.115

## 98MD053036-1 Torque Speed Curves

Motor Performance at 50% PWM

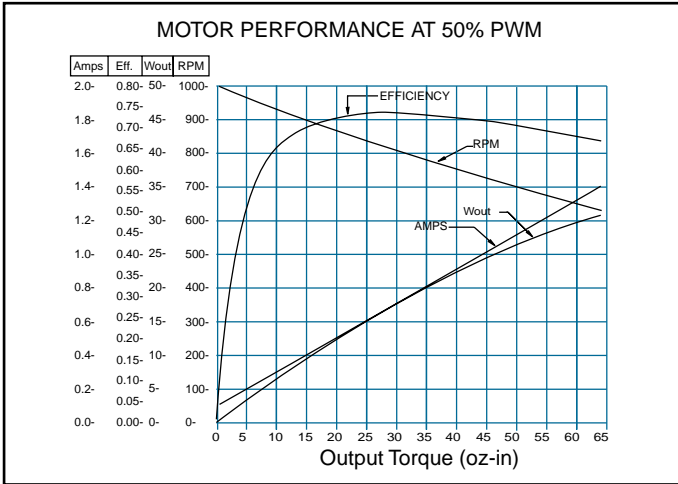

Motor Performance at 100% PWM

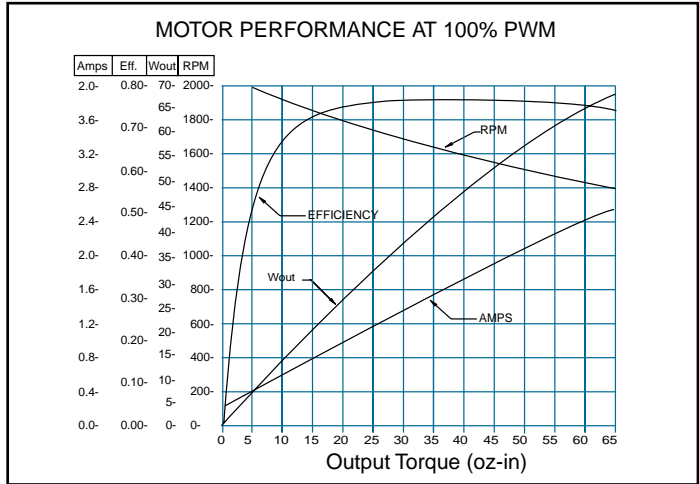

## 98MD062036-1 Torque Speed Curves

Motor Performance at 50% PWM

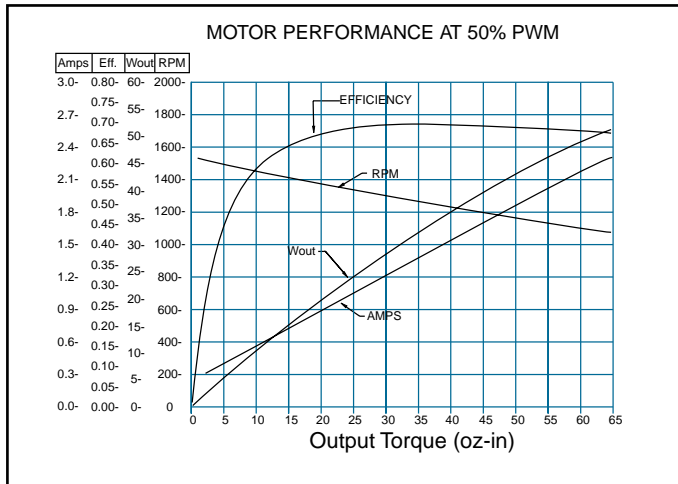

Motor Performance at 100% PWM

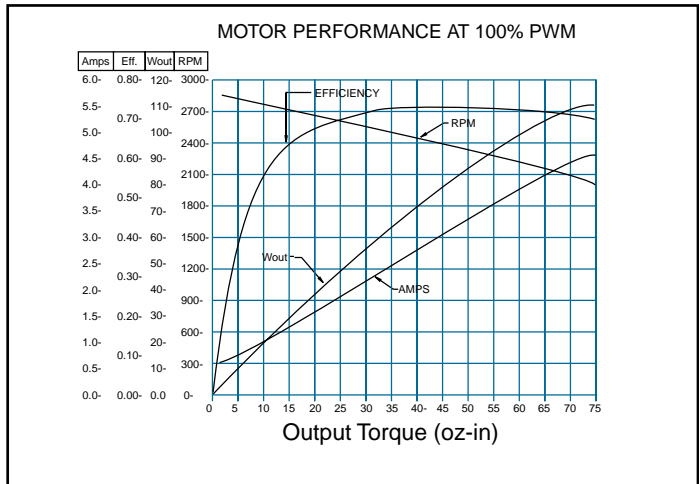

**Custom Design Capability.** Let THOMSON AIRPAX MECHATRONICS design the specific winding and torque constant that best fulfills your application in terms of efficiency. This will result in a motor of a frame size requiring the lowest current necessary to perform the task. This advantage may enable a smaller power supply to be used.

### Motor Connections

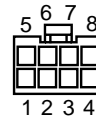

Pin	Color	Feature	Connection
1	Red	Motor Voltage	+ Motor Voltage
2	Black	Motor Ground	Motor Ground
3	Blue	5V Supply	4.75 - 5.25 VDC
4	Green	5V Ground	Logic Ground
5	Yellow	Enable	Active Ground
6	Purple	Direction	Active Ground
7	Orange	PWM Input	Ground for Full Speed
8	Brown	Tach Output	5V Square Wave

It is the responsibility of the product user to determine the suitability of Thomson components for a specific application. Defective products will be replaced without charge if promptly returned. No liability will be assumed beyond such replacement.

**Controller Block Diagram**

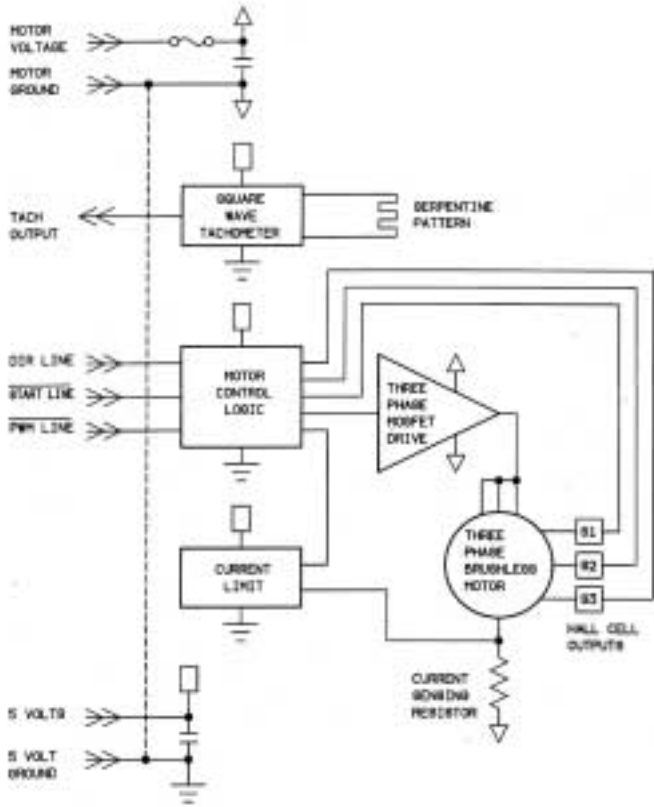

**Controller Features**

**Enable Input**

Connecting Pin 5 to ground enables motor operation.

**Direction Input**

Normal motor rotation direction is clockwise when viewed from shaft output end. With Pin 6 grounded, motor will run counterclockwise when viewed from shaft output end.

**PWM Input**

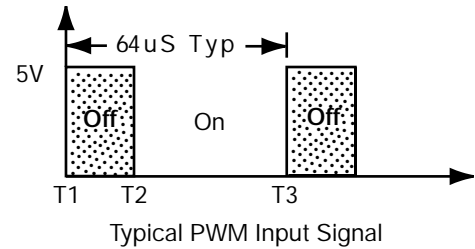

Full speed operation is achieved by grounding Pin 7 when Enable (Pin 5) is grounded. Motor output power (speed) is proportional to the inverse of the duty cycle of this Pulse Width Modulated signal. Through the motor circuitry, motor is 'on' only during the low state. In the above diagram, from T1 to T2 motor is 'off' and from T2 to T3 motor is 'on'. PWM limits the motor output power as expressed by the following equation:

$$\% \text{ Total Output Power} = \left( \frac{1}{\frac{T3}{T3-T2}} \right) \times 100$$

**Tachometer Output**

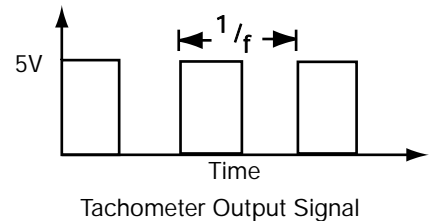

Pin 8 provides a 50 pulse per revolution 5V square wave representative of motor speed. Motor RPM is expressed as a multiple of the tachometer signal frequency as follows:

$$\text{RPM} = 1.2 \times f$$

**Part Numbering System**

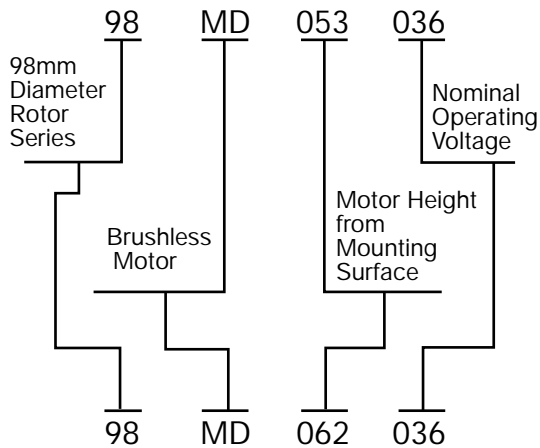





2 Channel Drive  
Port Washington, NY 11050 USA

*All Thomson Industries Manufacturing Locations are  
ISO 9000 Certified and Automotive Facilities  
Operate to QS-9000 Standards  
Three-time Winner General Motors Supplier of the Year*

**ISO 9000**

PRESORTED  
STANDARD  
US POSTAGE PAID  
THOMSON  
INDUSTRIES, INC.

## Thomson Airpax Mechatronics Brushless DC Motors



### FEATURES:

- Up to 5x longer life than conventional DC brush motors
- Low EMI/RFI - satisfies U.S. FCC and European CISPR 22-P standards
- Low temperature rise - 40°C vs. conventional 70°C
- Better speed stability
- Low audible noise - 55dba
- Low starting speed - as low as 100 RPM

The specifications in this publication are believed to be accurate and reliable. However, it is the responsibility of the product user to determine the suitability of Thomson products for a specific application. While defective products will be replaced without charge if promptly returned, no liability is assumed beyond such replacement. ©2001 Thomson Industries, Inc. Printed in the U.S.A. MMP 10K 1-22-01 KP 200004-06.qxd 12-03-000-6501

For technical assistance or to place an order:

#### DIVISIONAL HEADQUARTERS

THOMSON AIRPAX MECHATRONICS LLC	
7 McKee Place	E-mail: motorinfo@snet.net
Cheshire, CT 06410 USA	Phone: 1 (877) 9-AIRPAX (924-7729)
	Fax: 1 (877) 4-AIRPAX (424-7729)

#### EUROPE

THOMSON AIRPAX MECHATRONICS (UK) LIMITED	
9 Farnborough Business Centre	E-mail: info@tammail.com
Eelmoor Road, Farnborough	Phone: + (44) 1252-516051
Hants GU14 7XA, UK	Fax: + (44) 1252 516058

#### ASIA

THOMSON AIRPAX MECHATRONICS PTE LTD.	
Block 3015A, Ubi Road 1	E-mail: airpax@tamsales.com.sg
#07-08 Kampong Ubi	Phone: (65) 7474-888
Industrial Estate	Fax: (65) 7435-686
Singapore 408705	

#### CORPORATE HEADQUARTERS

THOMSON INDUSTRIES, INC.	
2 Channel Drive	E-mail: litrequest@thomsonmail.com
Port Washington, NY 11050 USA	Phone: 1-800-554-THOMSON
	Fax: 1-800-445-0329
	Web: www.thomsonindustries.com

# 44M100D Series Stepper Motors



Standard Motor

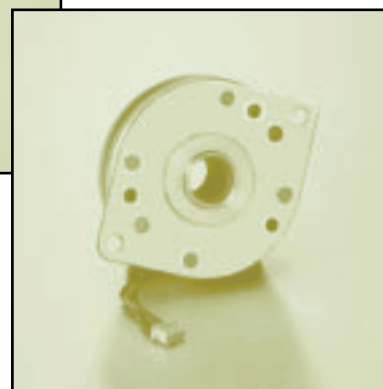
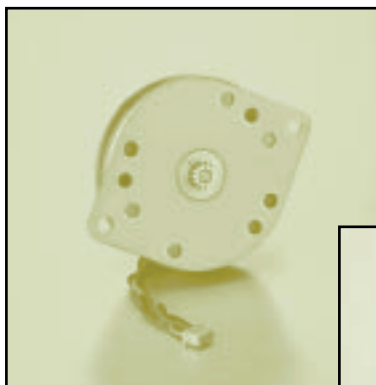

Typical Modifications

## Stepper Motor Features:

- 3.6° Step Angle (or 100 Steps per Revolution)
- 2 Watts Input Power per Winding
- Permanently Lubricated Sintered Bearings
- Available in Bipolar Construction Only
- Super Thin Design for Limited Space Application
- Excellent for Open-Loop Systems

## Specifications

Part Number	44M100D1B (Bipolar)
DC Operating Voltage (V)	5
Resistance per Winding (ohms) ±10%	12.5
Inductance per Winding (mH) ±20%	7.0
Holding Torque* (min, mNm/oz-in)	38.8/5.5
Detent Torque (max, mNm/oz-in)	19.7/2.8
Step Angle*	3.6° ± .25°
Steps per Revolution	100 steps
Rotor, Moment of Inertia (gm <sup>2</sup> )	8.20 x 10 <sup>-4</sup>
Insulation Resistance at 500 Vdc	100 megohms, min.
Lead Wire Type	AWG #28, UL 3265 (125°C, 150V)
Bearing Type	Sintered Bronze Sleeve
Operating Temperature (Casing)	100°C, MAX
Ambient Temperature Range	OPERATION: -0°C TO 60°C STORAGE: -40°C TO 85°C
Dielectric Strength	650±50 Vrms, 50Hz, for 1 to 2 seconds
Weight (g/oz)	80/2.82

\*Measured with Two Phases Energized

## Overall Dimensions

## Series 44M100D Stepper Motors

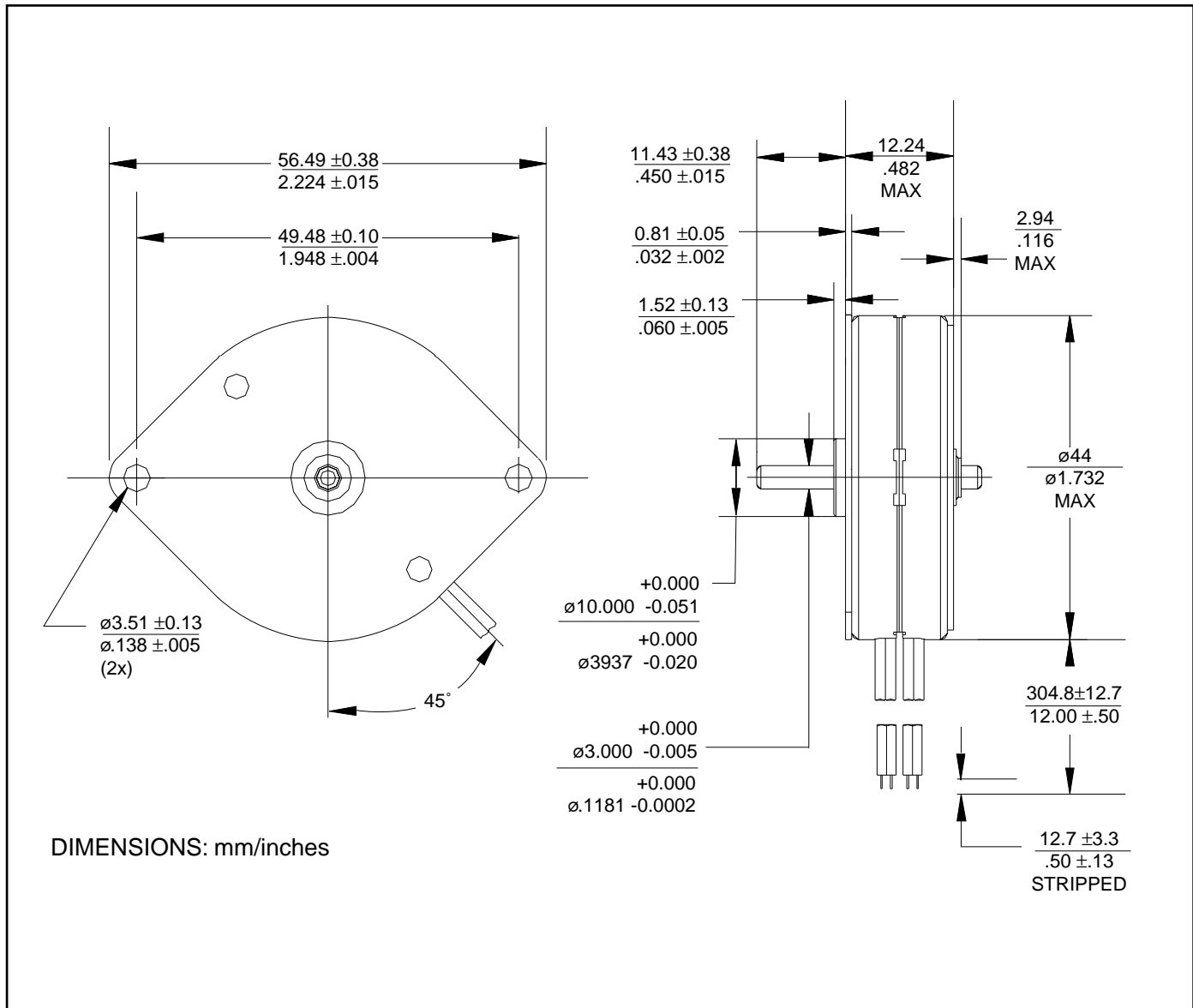

The above outline drawing represents standard construction as illustrated in photo on cover. Modifications to this design are possible to better satisfy specific application needs. They include, but are not limited to, changes of output shaft and mounting plate dimensions, lead egress position, bearing system, electrical windings, as well as adding transmission devices (mounted pinion or pulley) and connecting system (terminals and housing). Photos on cover show two typical modifications. Contact a THOMSON AIRPAX MECHATRONICS technical specialist to discuss your application.

It is the responsibility of the product user to determine the suitability of Thomson components for a specific application. Defective products will be replaced without charge if promptly returned. No liability will be assumed beyond such replacement.

**THOMSON AIRPAX**  
MECHATRONICS

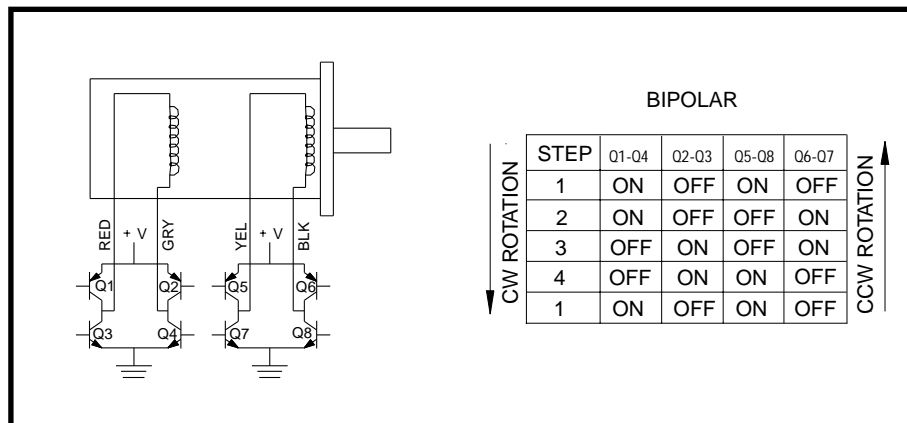
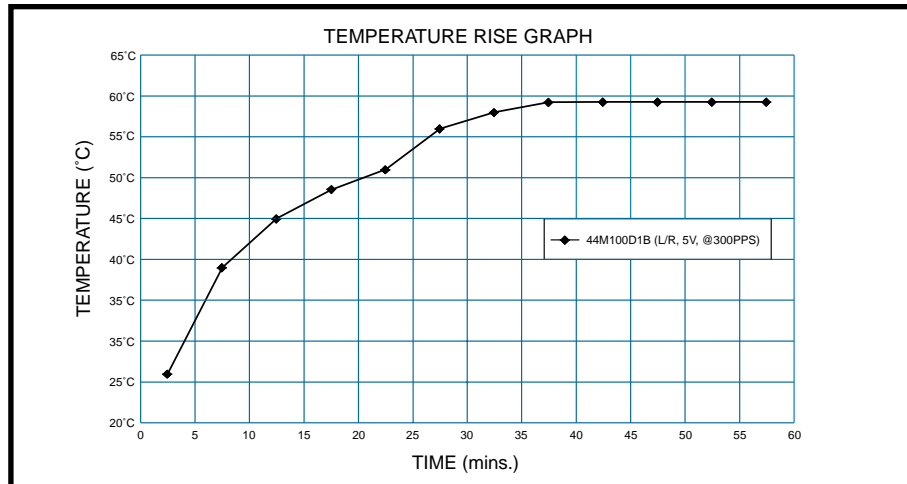
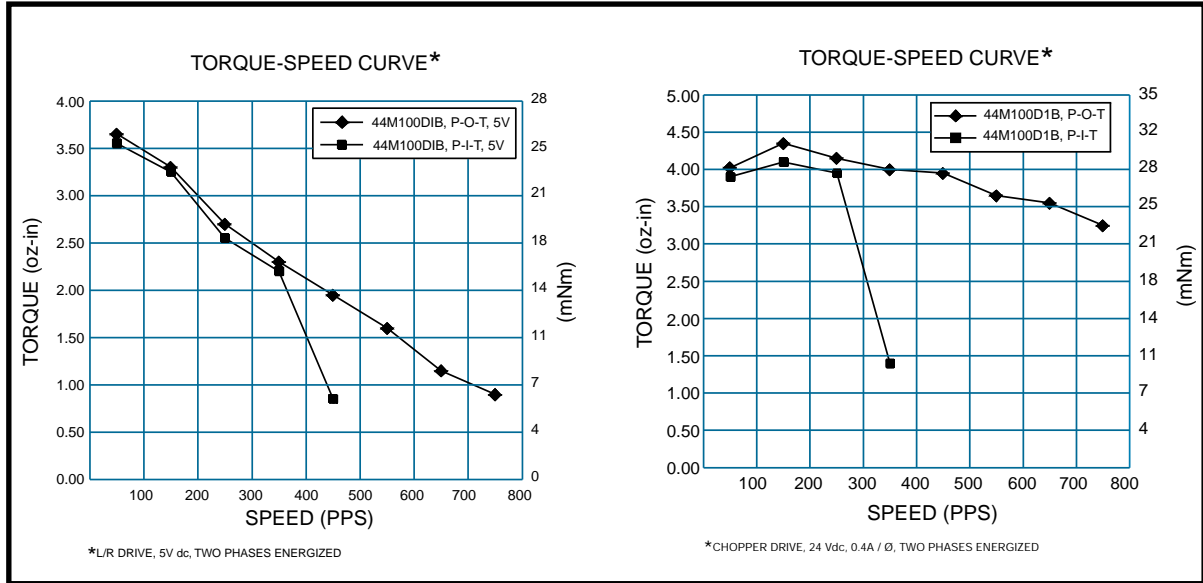

Schematic Bipolar Switching Sequence. Direction of Rotation Viewed from Shaft End.



2 Channel Drive  
Port Washington, NY 11050 USA

*All Thomson Industries Manufacturing Locations are  
ISO 9000 Certified and Automotive Facilities  
Operate to QS-9000 Standards  
Three-time Winner General Motors Supplier of the Year*

**ISO 9000**

PRESORTED  
STANDARD  
**US POSTAGE PAID**  
THOMSON  
INDUSTRIES, INC.

## Thomson Airpax Mechatronics Motors



### OVERVIEW AND CAPABILITIES:

- Large selection of permanent magnet stepper motors – from 15mm to 60mm
- Step angle range from 1.8° to 18°
- Pioneers in stepping motors, A.C. synchronous motors, brushless DC motors, gear motors, and digital linear actuators
- Fast, powerful, precise positioning
- Customization to meet your application requirements

The specifications in this publication are believed to be accurate and reliable. However, it is the responsibility of the product user to determine the suitability of Thomson products for a specific application. While defective products will be replaced without charge if promptly returned, no liability is assumed beyond such replacement. ©2001 Thomson Industries, Inc. Printed in the U.S.A. MP 10K 1-24-01 KP 200004-13.qxd 12-04-200-6001

For technical assistance or to place an order:

#### DIVISIONAL HEADQUARTERS

THOMSON AIRPAX MECHATRONICS LLC  
7 McKee Place  
Cheshire, CT 06410 USA  
E-mail: motorinfo@snet.net  
Phone: 1 (877) 9-AIRPAX (924-7729)  
Fax: 1 (877) 4-AIRPAX (424-7729)

#### EUROPE

THOMSON AIRPAX MECHATRONICS (UK) LIMITED  
9 Farnborough Business Centre  
Eelmoor Road, Farnborough  
Hants GU14 7XA, UK  
E-mail: info@tammail.com  
Phone: + (44) 1252-516051  
Fax: + (44) 1252 516058

#### ASIA

THOMSON AIRPAX MECHATRONICS PTE LTD.  
Block 3015A, Ubi Road 1  
#07-08 Kampong Ubi  
Industrial Estate  
Singapore 408705  
E-mail: airpax@tamsales.com.sg  
Phone: (65) 7474-888  
Fax: (65) 7435-686

#### CORPORATE HEADQUARTERS

THOMSON INDUSTRIES, INC.  
2 Channel Drive  
Port Washington, NY 11050 USA  
E-mail: litrequest@thomsonmail.com  
Phone: 1-800-554-THOMSON  
Fax: 1-800-445-0329  
Web: www.thomsonindustries.com

# 55M048D Series Stepper Motors



Standard Motor

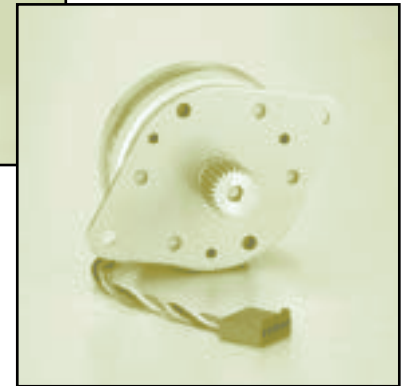

Typical Modifications

## Stepper Motor Features:

- 7.5° Step Angle (or 48 Steps per Revolution)
- 4.8 Watts Input Power per Winding
- Permanently Lubricated Sintered Bearings
- Available in Unipolar or Bipolar Construction
- Superior Torque Performance
- Excellent for Open-Loop Systems
- Widely Used Frame size in Various Industries

Specifications				
	UNIPOLAR		BIPOLAR	
Part Number	55M048D1U	55M048D2U	55M048D1B	55M048D2B
DC Operating Voltage (V)	5	12	5	12
Resistance per Winding (ohms) ±10%	5.2	30.0	5.2	30.0
Inductance per Winding (mH) ± 20%	4.7	31.1	9.6	62.7
Holding Torque* (min, mNm/oz-in)	180/25.5	198/28	236/33.5	247/35
Detent Torque (max, mNm/oz-in)	38.8/5.5			
Step Angle*	7.5° ± .5°			
Steps per Revolution	48 Steps			
Rotor, Moment of Inertia (gm <sup>2</sup> )	5.56 x 10 <sup>-3</sup>			
Insulation Resistance at 500 Vdc	100 megohms, min.			
Lead Wire Type	AWG #26, UL1430 (105°C, 300V)			
Bearing Type	Sintered Bronze Sleeve			
Max Operating Temperature	100°C			
Ambient Temperature Range	OPERATION: -0°C TO 60°C STORAGE: -40°C TO 85°C			
Dielectric Strength	650 ±50 Vrms, 50 Hz, for 1 to 2 seconds			
Weight (g/oz)	270/9.5			

\*Measured with Two Phases Energized

Overall Dimensions

Series 55M048D Stepper Motors

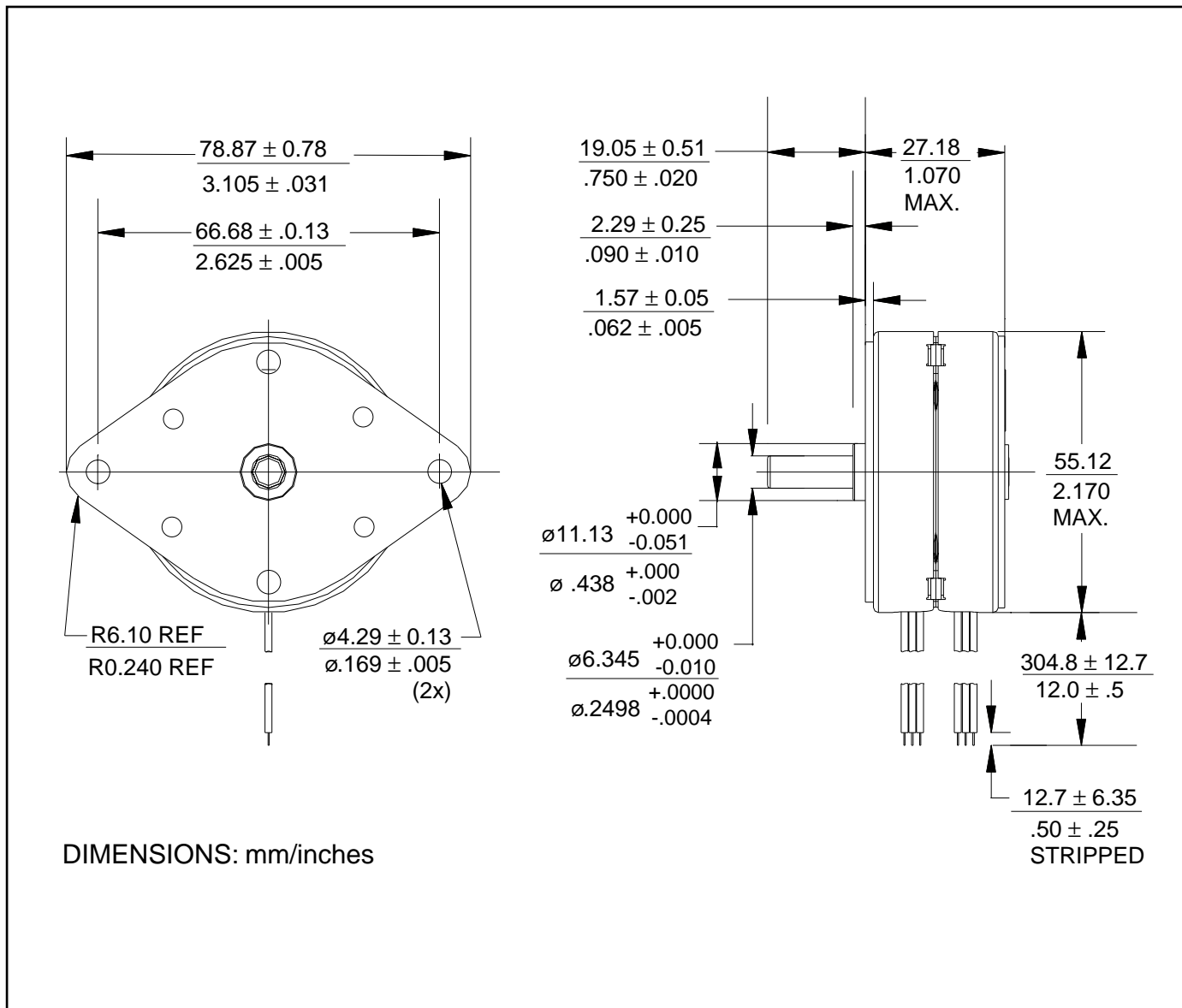

The above outline drawing represents standard construction as illustrated in photo on cover. Modifications to this design are possible to better satisfy specific application needs. They include, but are not limited to, changes of output shaft and mounting plate dimensions, lead egress position, bearing system, electrical windings, as well as adding transmission devices (mounted pinion or pulley) and connecting system (terminals and housing). Photos on cover show two typical modifications. Contact a THOMSON AIRPAX MECHATRONICS technical specialist to discuss your application.

It is the responsibility of the product user to determine the suitability of Thomson components for a specific application. Defective products will be replaced without charge if promptly returned. No liability will be assumed beyond such replacement.

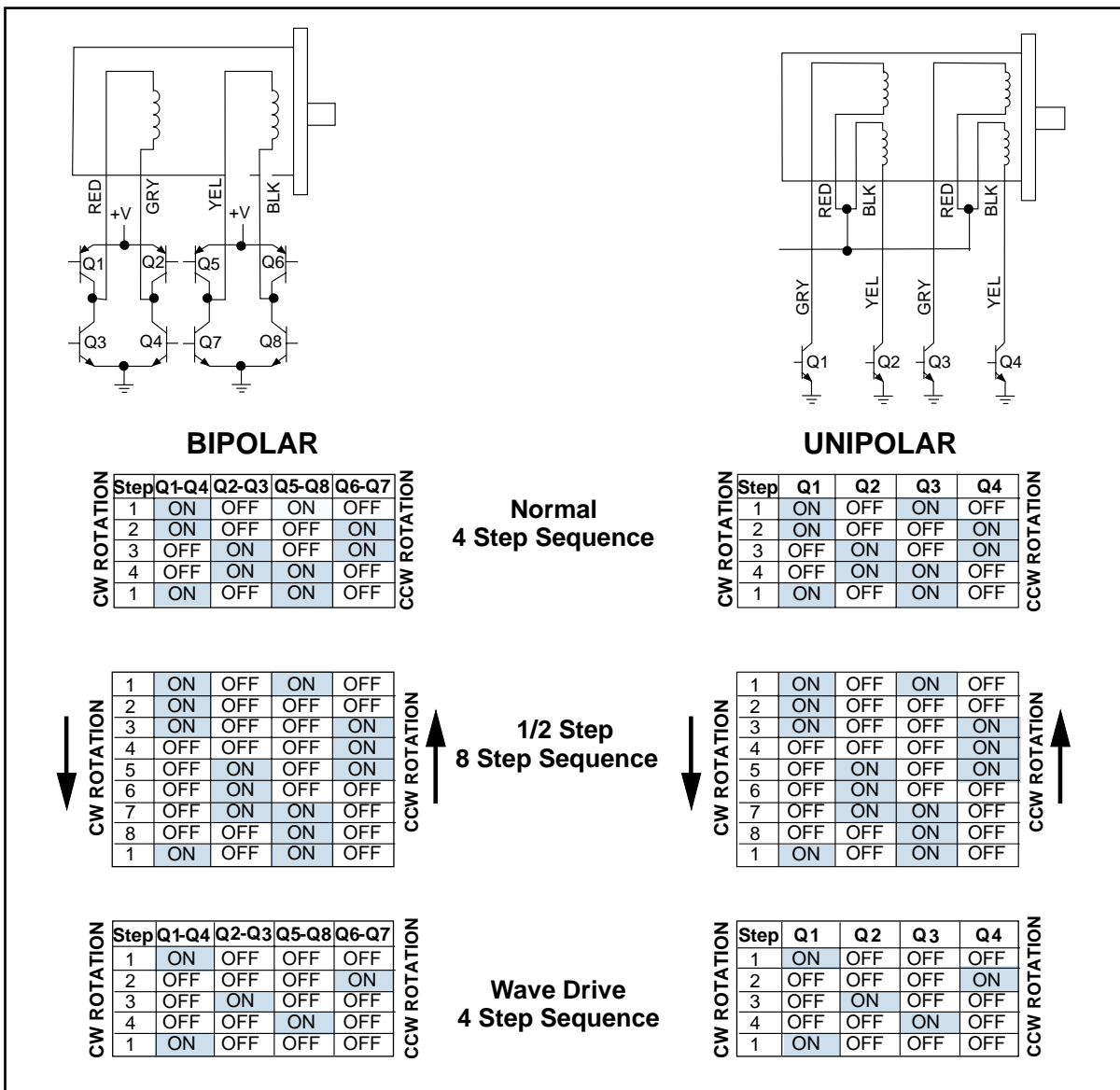
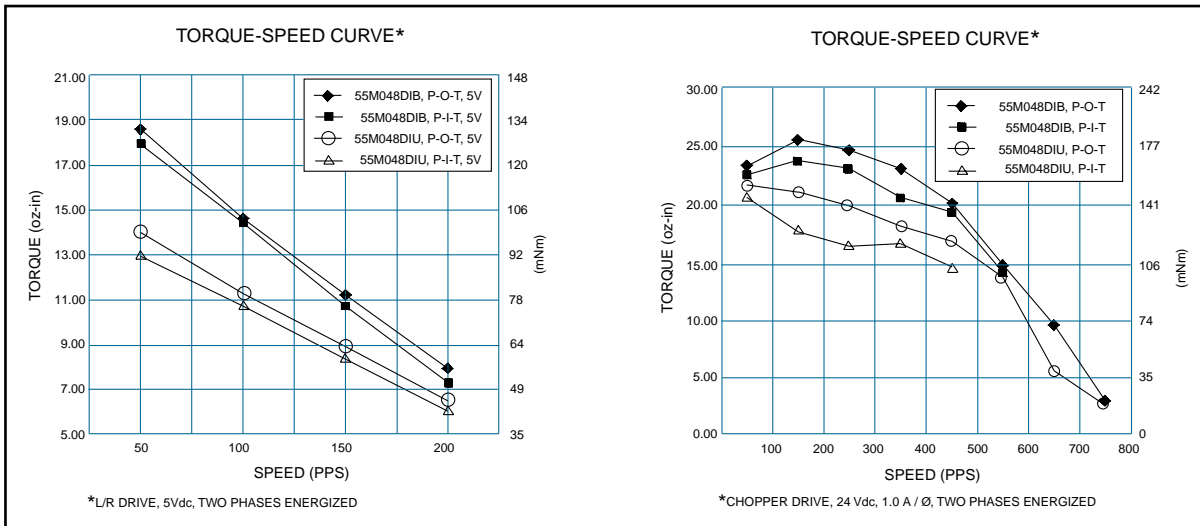

Schematic Bipolar and Unipolar Switching Sequence. Direction of Rotation Viewed from Shaft End.





2 Channel Drive  
Port Washington, NY 11050 USA

*All Thomson Industries Manufacturing Locations are  
ISO 9000 Certified and Automotive Facilities  
Operate to QS-9000 Standards  
Three-time Winner General Motors Supplier of the Year*

**ISO 9000**

PRESORTED  
STANDARD  
US POSTAGE PAID  
THOMSON  
INDUSTRIES, INC.

## Thomson Airpax Mechatronics Motors



### OVERVIEW AND CAPABILITIES:

- Large selection of permanent magnet stepper motors – from 15mm to 60mm
- Step angle range from 1.8° to 18°
- Pioneers in stepping motors, A.C. synchronous motors, brushless DC motors, gear motors, and digital linear actuators
- Fast, powerful, precise positioning
- Customization to meet your application requirements

The specifications in this publication are believed to be accurate and reliable. However, it is the responsibility of the product user to determine the suitability of Thomson products for a specific application. While defective products will be replaced without charge if promptly returned, no liability is assumed beyond such replacement. ©2001 Thomson Industries, Inc. Printed in the U.S.A. MP 10K 1-24-01 KP 200004-12.qxd Lit 12-04-300-6501-1

For technical assistance or to place an order:

#### DIVISIONAL HEADQUARTERS

THOMSON AIRPAX MECHATRONICS LLC  
7 McKee Place  
Cheshire, CT 06410 USA  
E-mail: motorinfo@snet.net  
Phone: 1 (877) 9-AIRPAX (924-7729)  
Fax: 1 (877) 4-AIRPAX (424-7729)

#### EUROPE

THOMSON AIRPAX MECHATRONICS (UK) LIMITED  
9 Farnborough Business Centre  
Eelmoor Road, Farnborough  
Hants GU14 7XA, UK  
E-mail: info@tammail.com  
Phone: + (44) 1252-516051  
Fax: + (44) 1252 516058

#### ASIA

THOMSON AIRPAX MECHATRONICS PTE LTD.  
Block 3015A, Ubi Road 1  
#07-08 Kampong Ubi  
Industrial Estate  
Singapore 408705  
E-mail: airpax@tamsales.com.sg  
Phone: (65) 7474-888  
Fax: (65) 7435-686

#### CORPORATE HEADQUARTERS

THOMSON INDUSTRIES, INC.  
2 Channel Drive  
Port Washington, NY 11050 USA  
E-mail: litrequest@thomsonmail.com  
Phone: 1-800-554-THOMSON  
Fax: 1-800-445-0329  
Web: www.thomsonindustries.com

FOR MORE INFORMATION ON THE COMPLETE LINE OF THOMSON AIRPAX MECHATRONICS PRODUCTS  
• PERMANENT MAGNET STEPPER AND GEARED MOTORS • DIGITAL LINEAR ACTUATORS • BRUSHLESS DC MOTORS

C O N T A C T

[www.thomsonmotors.com](http://www.thomsonmotors.com)

---

**HEADQUARTERS (North America)**

THOMSON AIRPAX MECHATRONICS LLC  
7 McKee Place  
Cheshire, CT 06410 USA

E-mail: [motorinfo@snet.net](mailto:motorinfo@snet.net)  
Phone: 1 (877) 9-AIRPAX (924-7729)  
Fax: 1 (877) 4-AIRPAX (424-7729)

**EUROPE**

THOMSON AIRPAX MECHATRONICS (UK) LIMITED  
9 Farnborough Business Centre  
Eelmoor Road, Farnborough  
Hants GU14 7XA Great Britain

E-mail: [info@tammail.com](mailto:info@tammail.com)  
Phone: (44) 1252 516051  
Fax: (44) 1252 516058

**ASIA**

THOMSON AIRPAX MECHATRONICS PTE LTD.

Block 3015A, Ubi Road 1  
#07-08 Kampong Ubi  
Industrial Estate  
Singapore 408705

E-mail: [airpax@tamsales.com.sg](mailto:airpax@tamsales.com.sg)  
Phone: (65) 7474-888  
Fax: (65) 7435-686

---

**Thomson Airpax Mechatronics is a member of the  
Thomson Industries Group of Companies**

THOMSON INDUSTRIES, INC.  
2 Channel Drive  
Port Washington, NY 11050 USA

E-mail: [litrequest@thomsonmail.com](mailto:litrequest@thomsonmail.com)  
Phone: 1-800-554-THOMSON or 1-516-883-8000  
Fax: 1-800-445-0329 or 1-516-883-9039  
Web: [www.thomsonindustries.com](http://www.thomsonindustries.com)