

CSE 442 - Data Visualization

# Graphical Perception

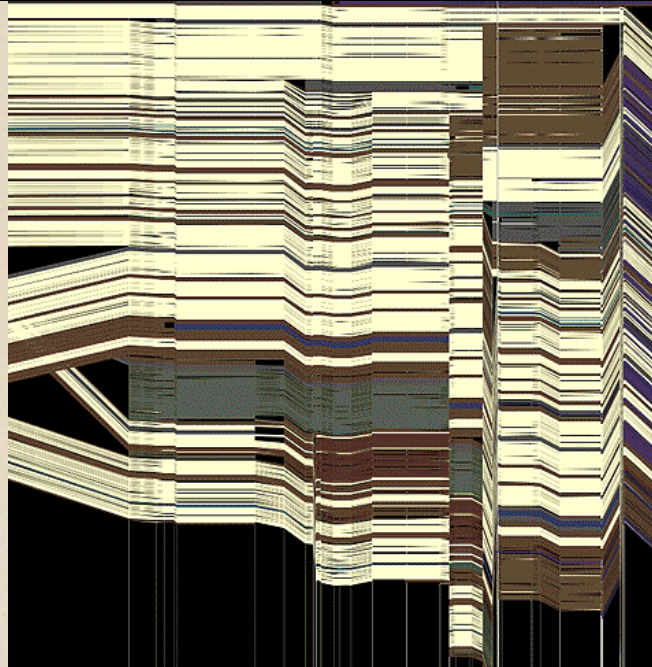
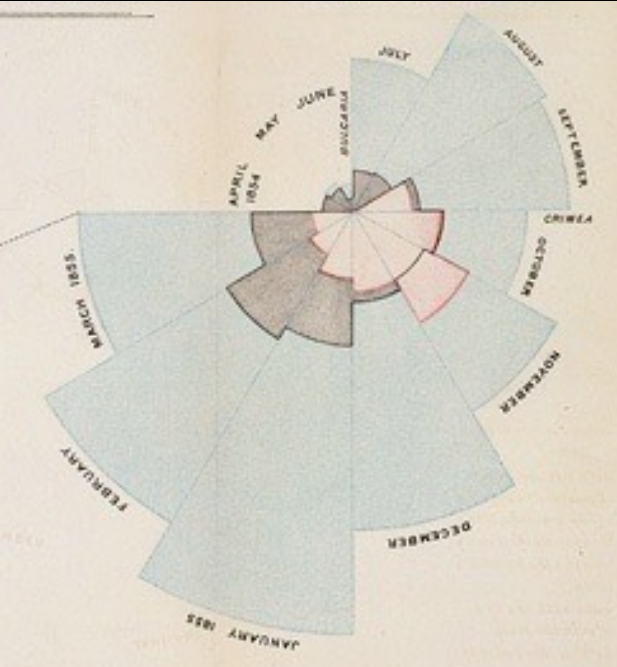

Jeffrey Heer University of Washington

# Design Principles [Mackinlay 86]

## Expressiveness

A set of facts is *expressible* in a visual language if the sentences (i.e. the visualizations) in the language express all the facts in the set of data, and only the facts in the data.

## Effectiveness

A visualization is more *effective* than another visualization if the information conveyed by one visualization is more readily perceived than the information in the other visualization.

# Design Principles *Translated*

**Tell the truth and nothing but the truth**  
(don't lie, and don't lie by omission)

**Use encodings that people decode better**  
(where better = faster and/or more accurate)

# Which best encodes quantities?

Position

Length

Area

Volume

Value (Brightness)

Color Hue

Orientation (Angle)

Shape

# Effectiveness Rankings [Mackinlay 86]

## QUANTITATIVE

Position  
Length  
Angle  
Slope  
Area (Size)  
Volume  
Density (Value)  
Color Sat  
Color Hue  
Texture  
Connection  
Containment  
Shape

## ORDINAL

Position  
Density (Value)  
Color Sat  
Color Hue  
Texture  
Connection  
Containment  
Length  
Angle  
Slope  
Area (Size)  
Volume  
Shape

## NOMINAL

Position  
Color Hue  
Texture  
Connection  
Containment  
Density (Value)  
Color Sat  
Shape  
Length  
Angle  
Slope  
Area  
Volume

# Graphical Perception

The ability of viewers to interpret visual (graphical) encodings of information and thereby decode information in graphs.

# Topics

Signal Detection

Magnitude Estimation

Pre-Attentive Processing

Using Multiple Visual Encodings

Gestalt Grouping

Change Blindness

**Detection**



# Detecting Brightness



Which is brighter?

# Detecting Brightness

(128, 128, 128)



(144, 144, 144)



Which is brighter?



# Detecting Brightness

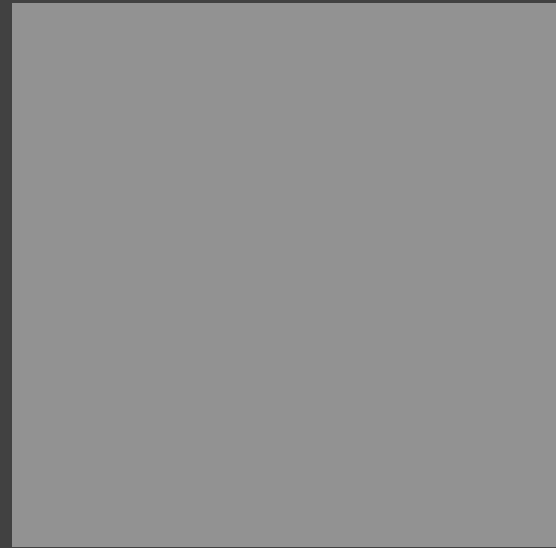

Which is brighter?

# Detecting Brightness

(134, 134, 134)

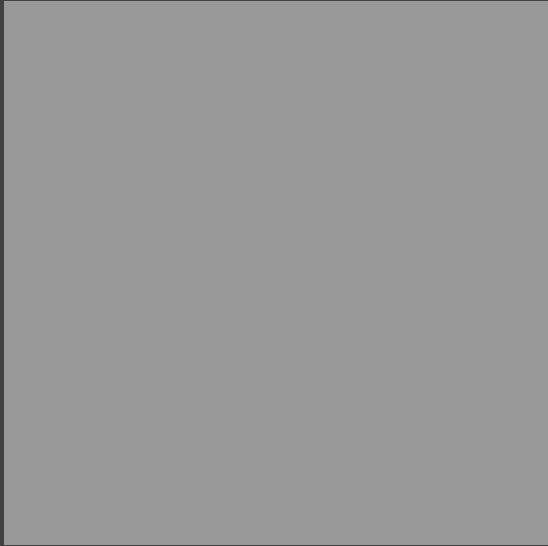

(128, 128, 128)

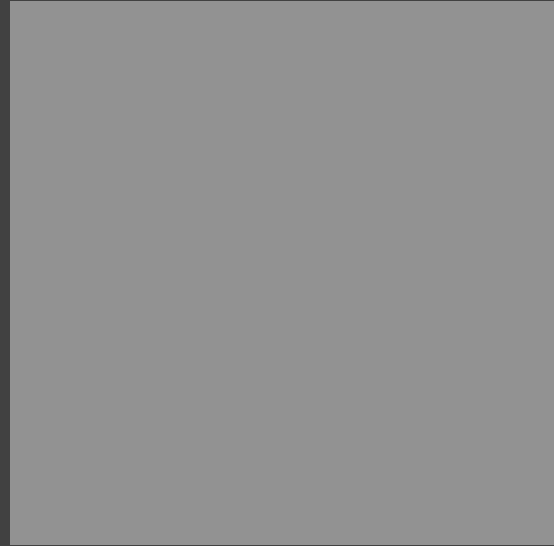

Which is brighter?

# Just Noticeable Difference (JND)

JND (Weber's Law)

Perceived  
Change →

$$\Delta S = k \frac{\Delta I}{I}$$

Scale Factor  
(Empirically Determined)

← Change of  
Intensity

← Physical  
Intensity

Ratios more important than magnitude

Most continuous variation in stimuli are  
perceived in discrete steps



# Encoding Data with Color

Value is perceived as ordered

∴ Encode ordinal variables (O)

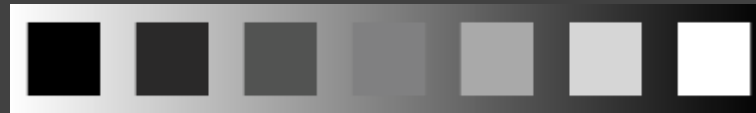

∴ Encode continuous variables (Q) [not as well]

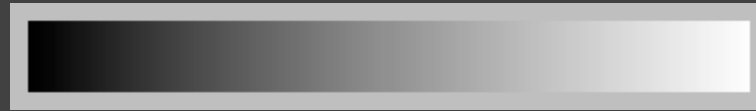

Hue is normally perceived as unordered

∴ Encode nominal variables (N) using color



# Steps in Font Size

Sizes standardized in 16<sup>th</sup> century

a	a	a	a	a	a	a	a	a	a	a	a	a	a	a	a
6	7	8	9	10	11	12	14	16	18	21	24	36	48	60	72



# Magnitude Estimation

*A Quick Experiment...*

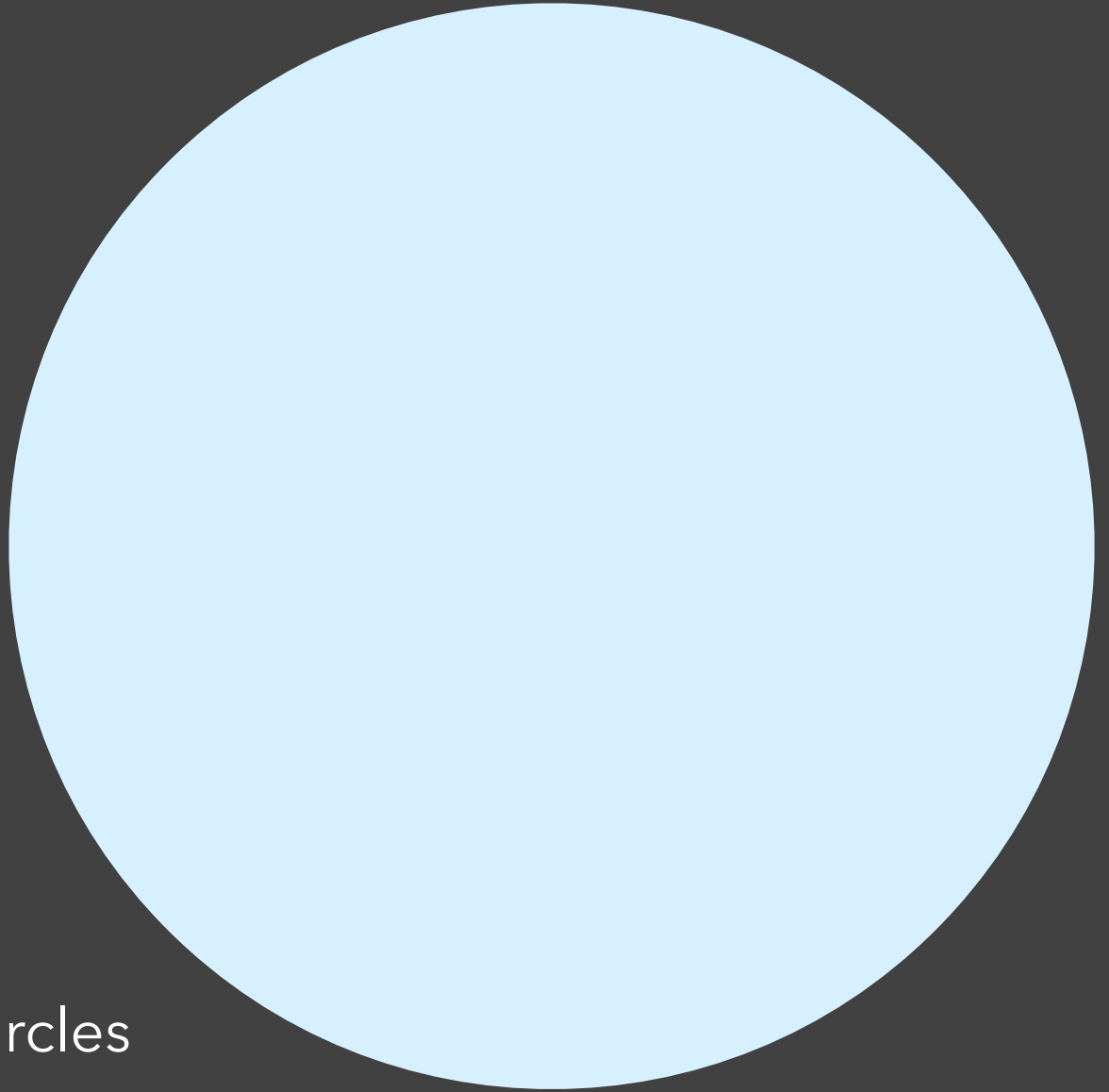
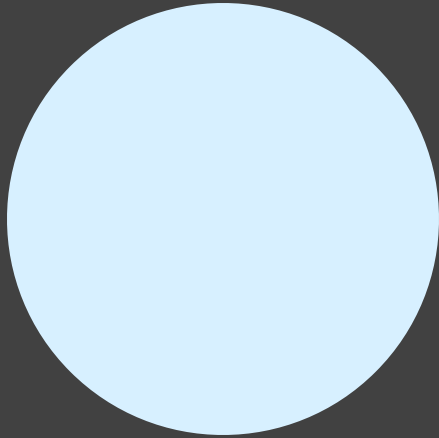

Compare area of circles

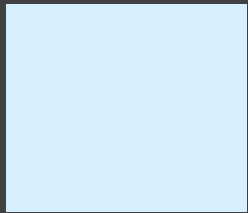
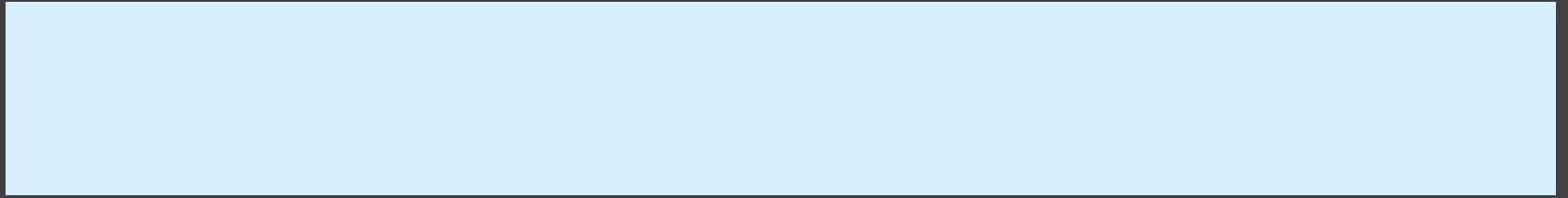

Compare length of bars

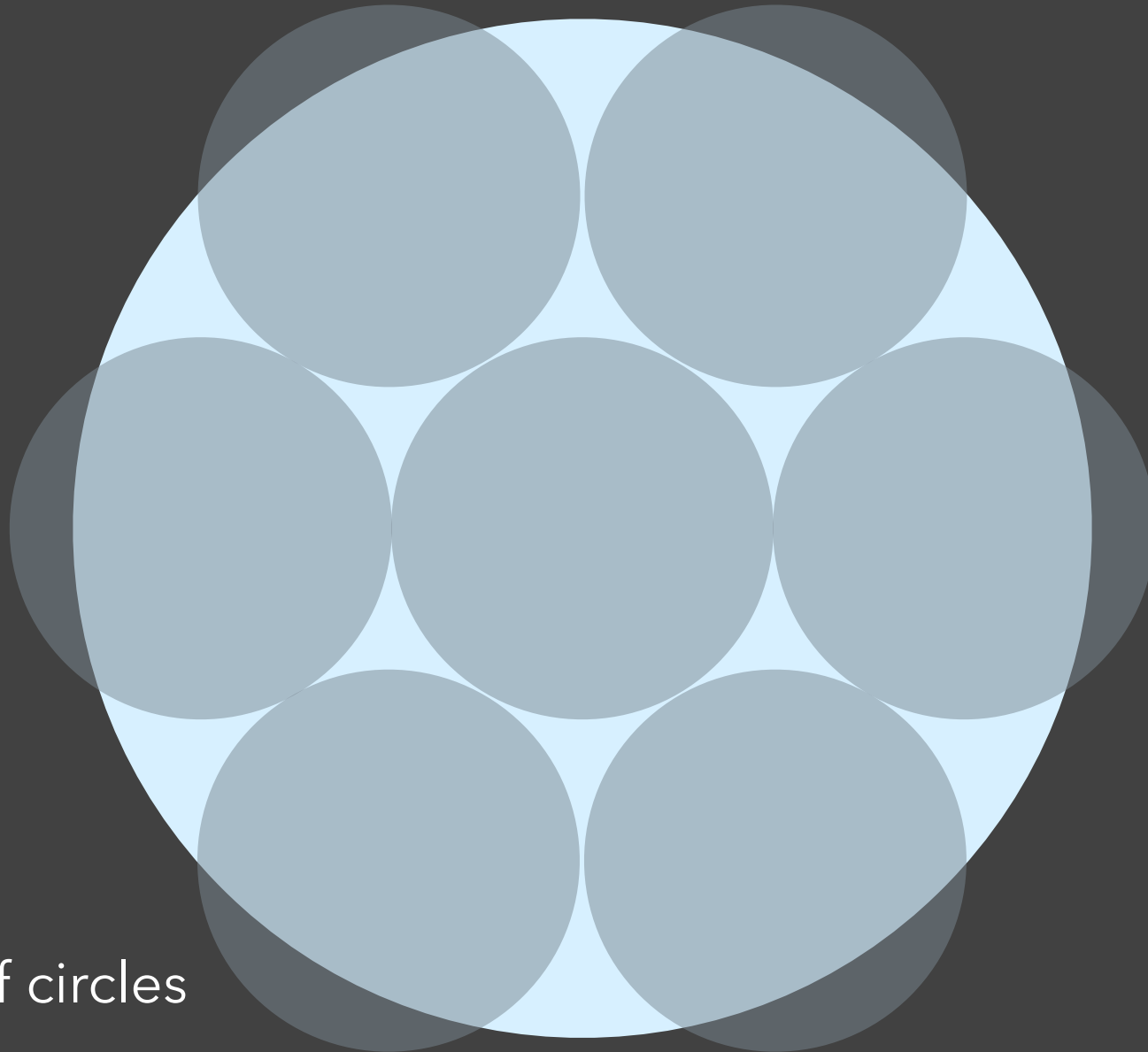
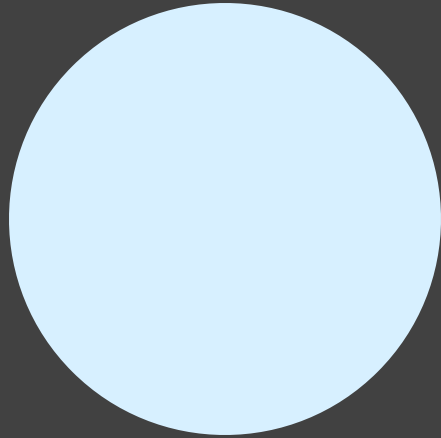

Compare area of circles

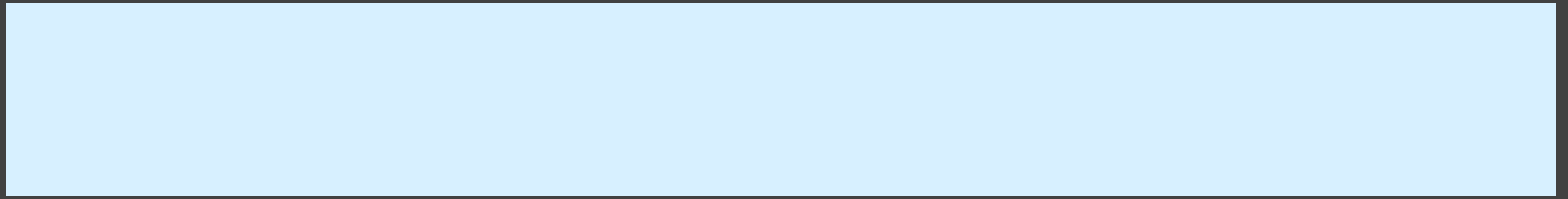

Compare length of bars

# Steven's Power Law

Exponent  
(Empirically Determined)

$$S = I^p$$

↑                      ↑  
Perceived            Physical  
Sensation            Intensity

Predicts bias, not necessarily accuracy!

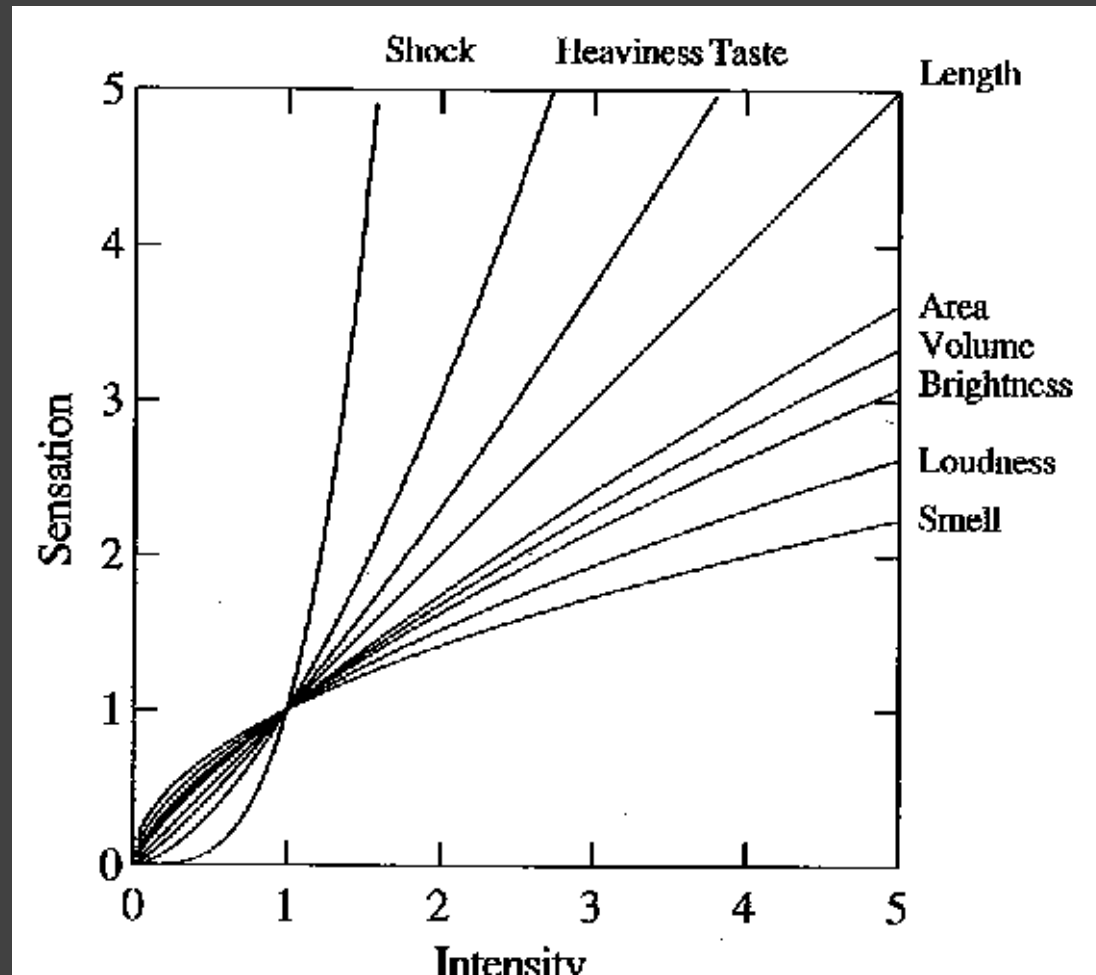

[Graph from Wilkinson 99, based on Stevens 61]

# Exponents of Power Law

Sensation	Exponent
Loudness	0.6
Brightness	0.33
Smell	0.55 (Coffee) - 0.6 (Heptane)
Taste	0.6 (Saccharine) -1.3 (Salt)
Temperature	1.0 (Cold) – 1.6 (Warm)
Vibration	0.6 (250 Hz) – 0.95 (60 Hz)
Duration	1.1
Pressure	1.1
Heaviness	1.45
Electric Shock	3.5

[Psychophysics of Sensory Function, Stevens 61]



# Apparent Magnitude Scaling

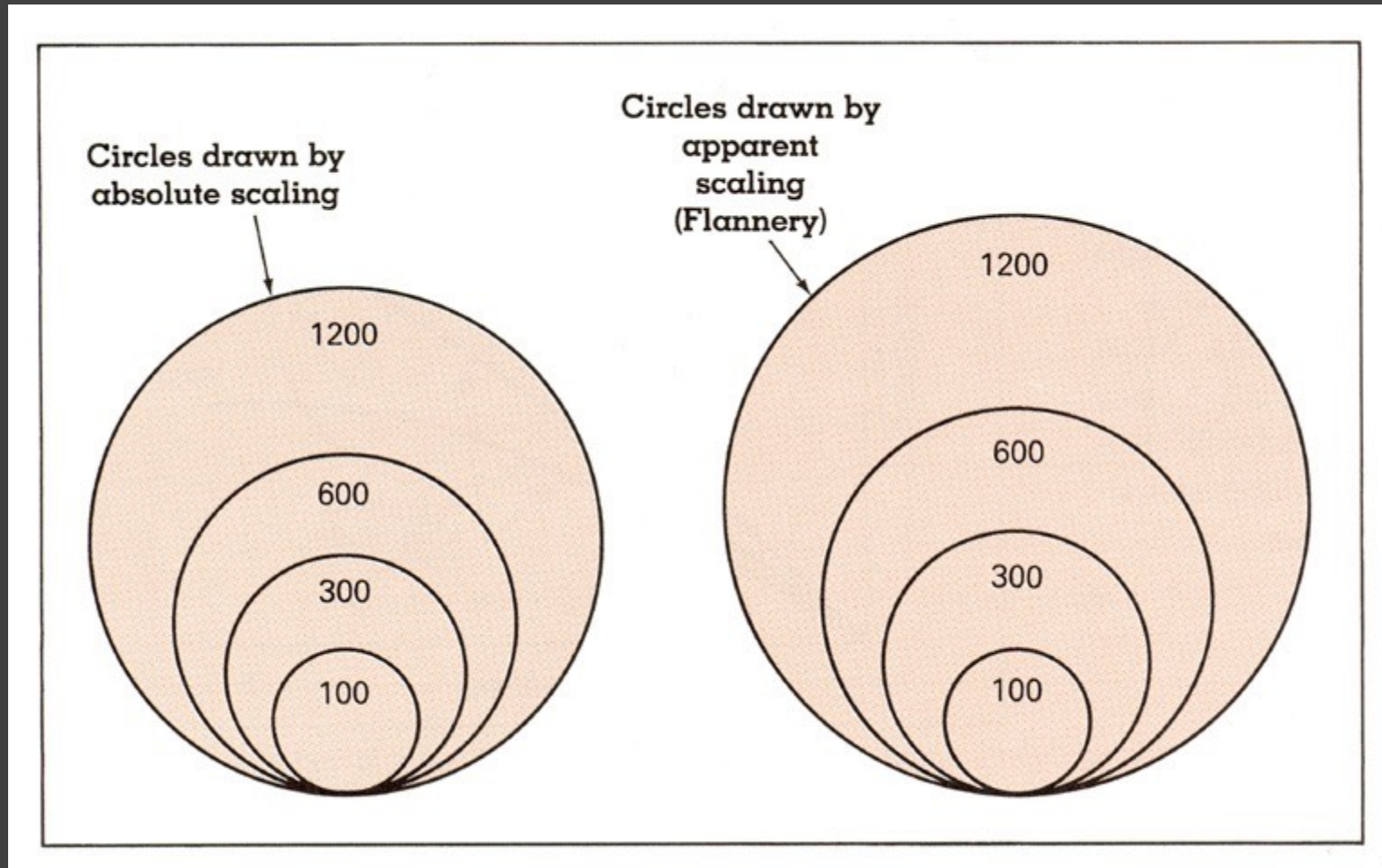

[Cartography: Thematic Map Design, Figure 8.6, p. 170, Dent, 96]

$$S = 0.98A^{0.87} \text{ [from Flannery 71]}$$

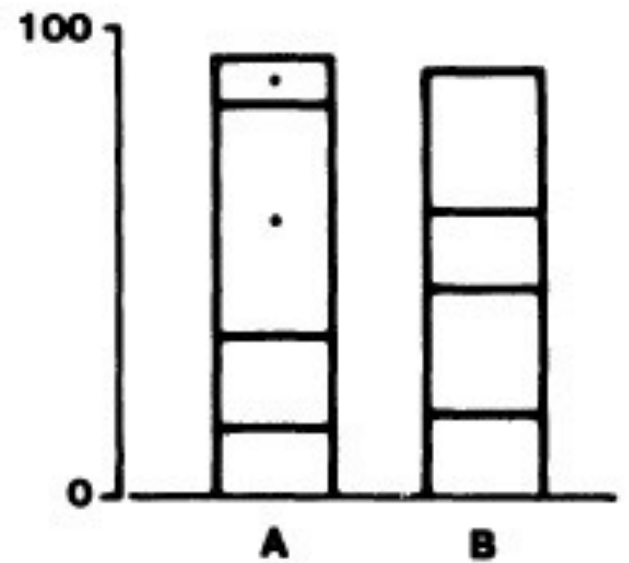
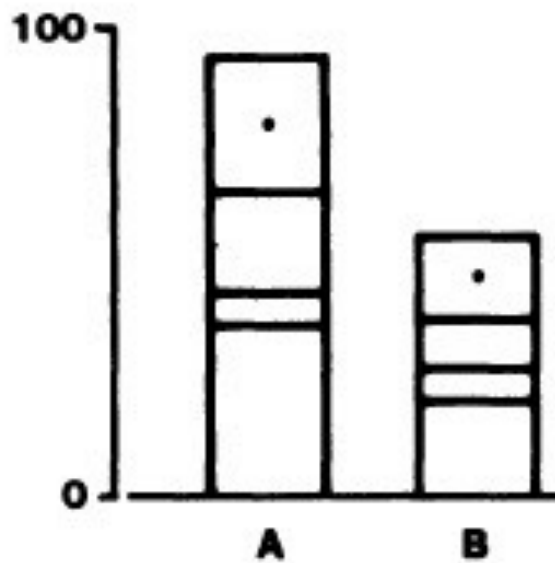
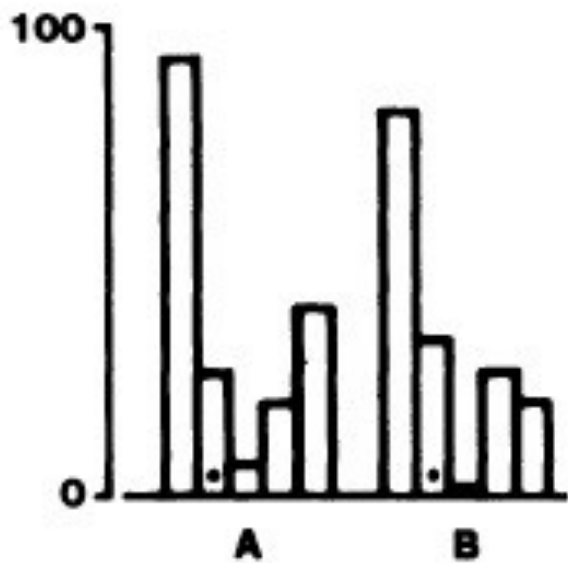

**Graphical Perception** [Cleveland & McGill 84]

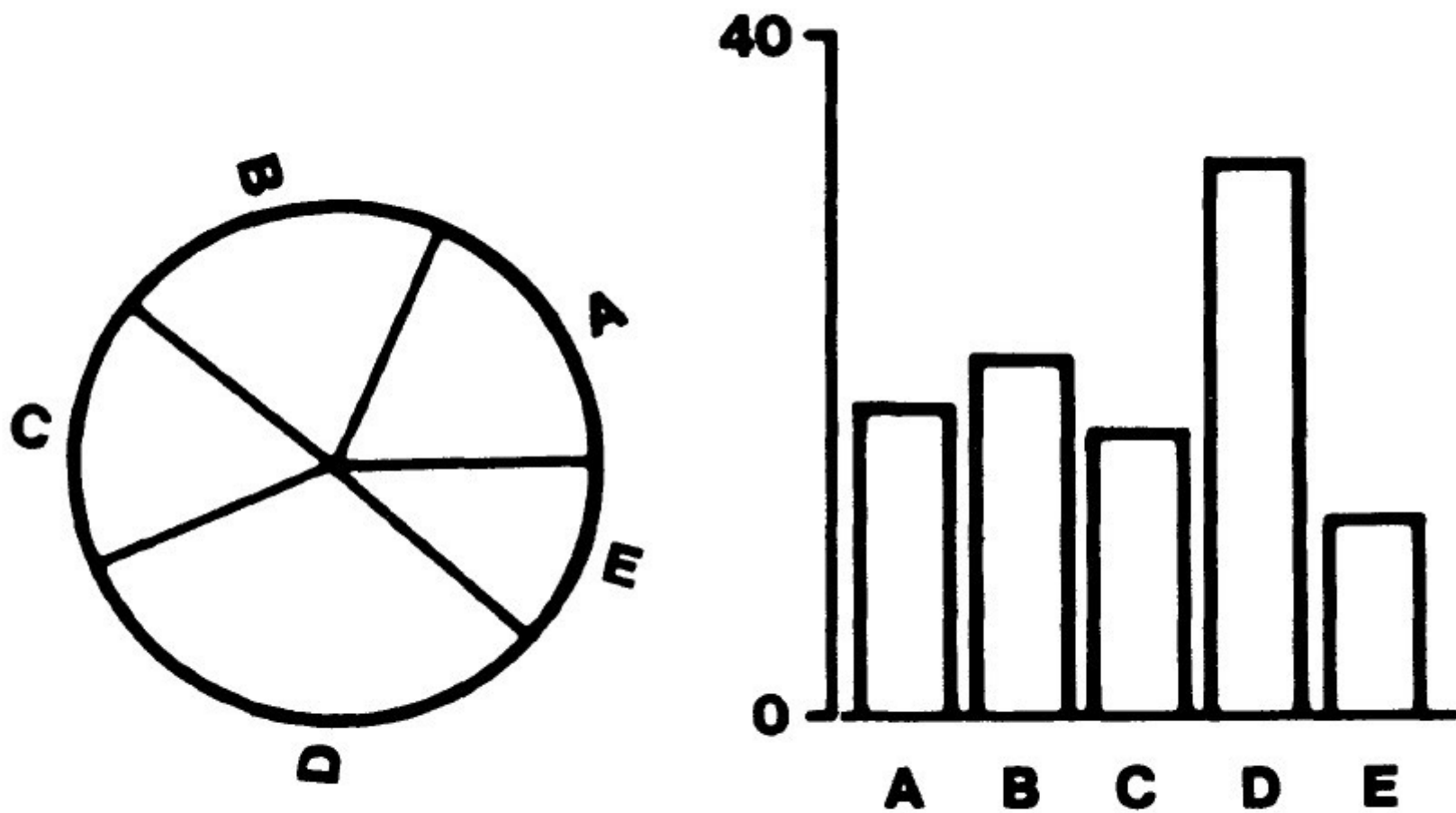

*Figure 3. Graphs from position-angle experiment.*

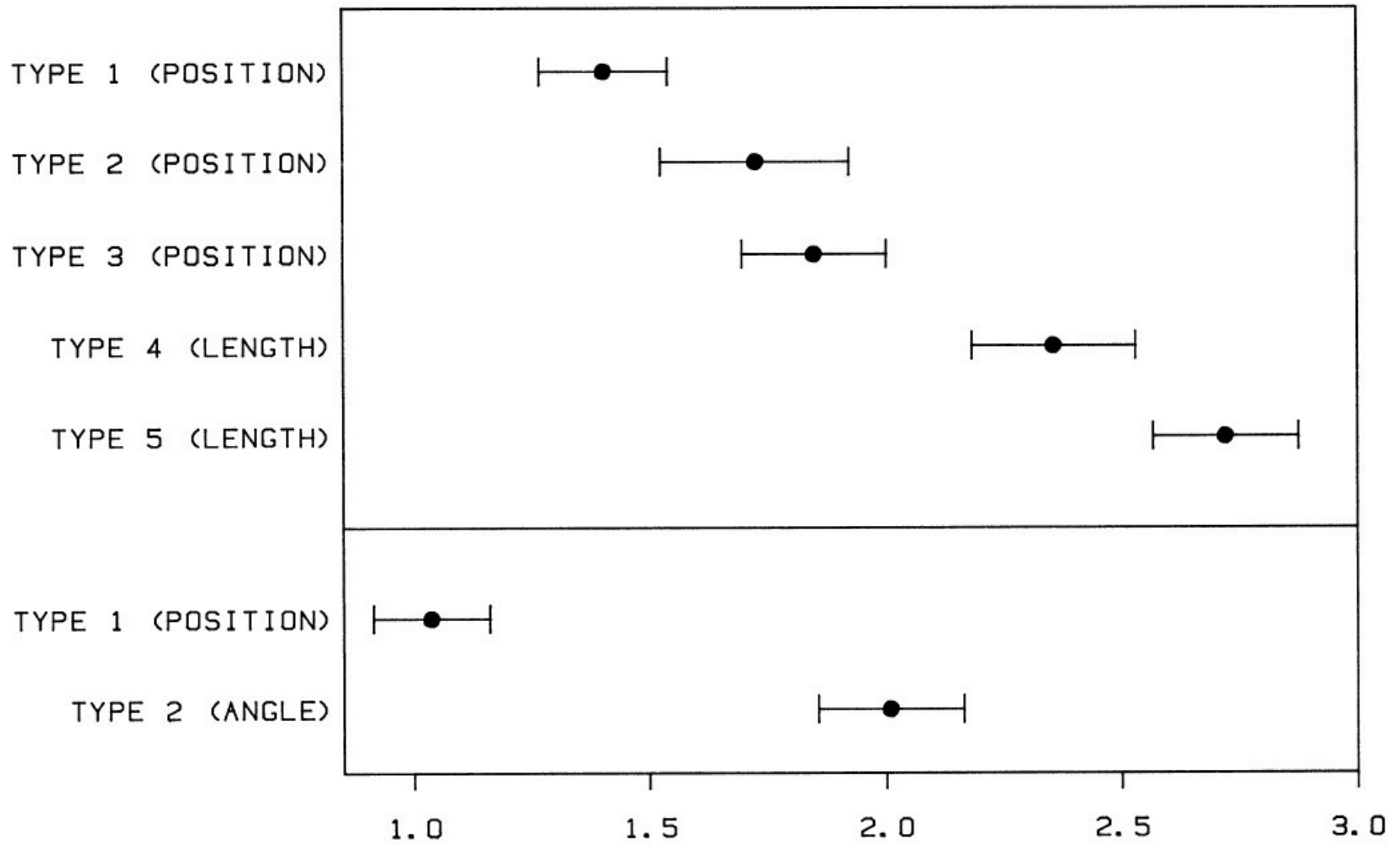

Cleveland & McGill, '84

LOG BASE 2 (ABSOLUTE ERROR + .125)

Figure 16. Log absolute error means and 95% confidence intervals for judgment types in position-length experiment (top) and position-angle experiment (bottom).

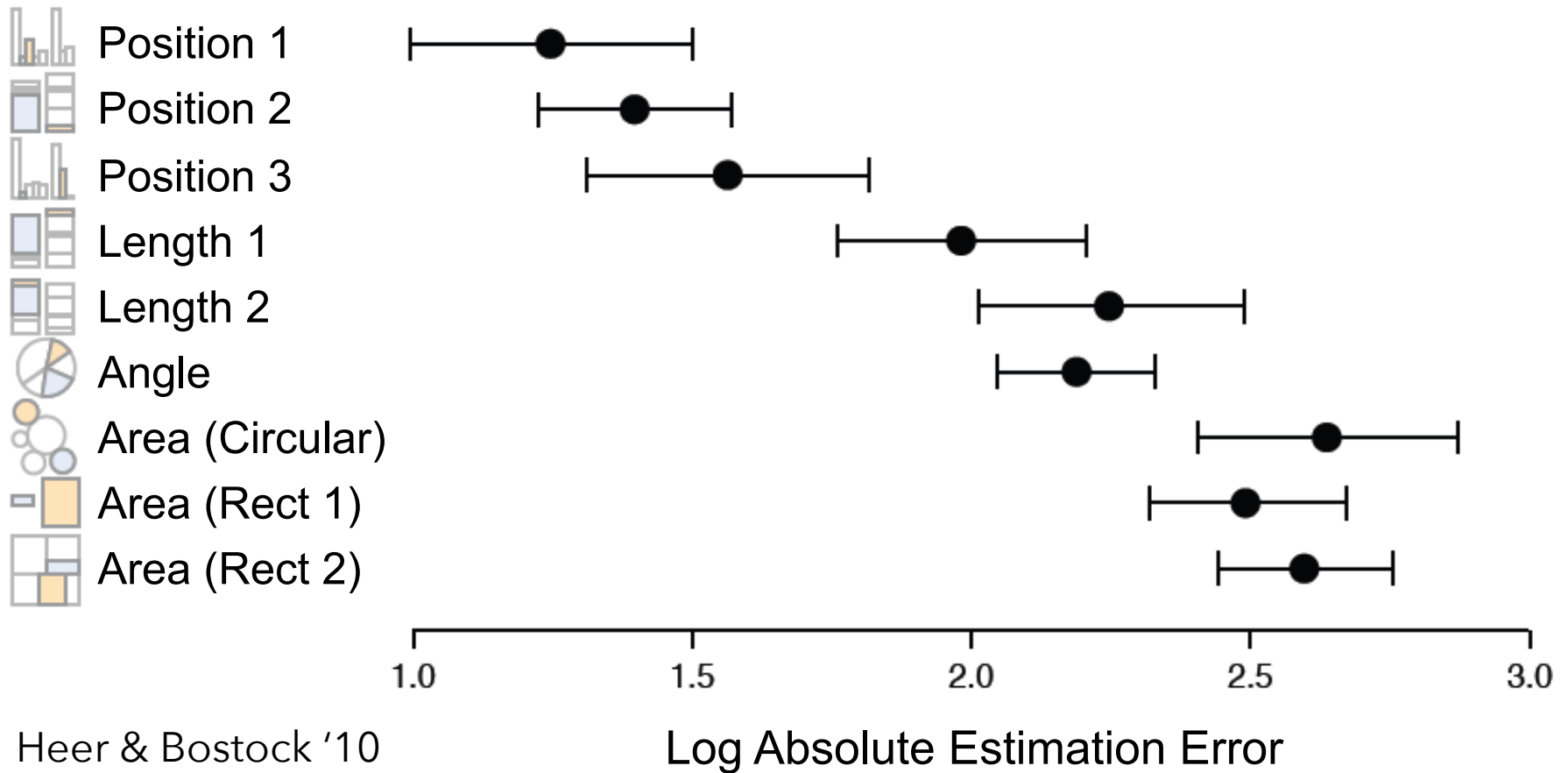

# Graphical Perception Experiments

Empirical estimates of encoding effectiveness

# Relative Magnitude Comparison

Most accurate



Least accurate



Position (common) scale



Position (non-aligned) scale



Length



Slope



Angle



Area



Volume



Color hue-saturation-density

# Effectiveness Rankings [Mackinlay 86]

## QUANTITATIVE

Position  
Length  
Angle  
Slope  
Area (Size)  
Volume  
Density (Value)  
Color Sat  
Color Hue  
Texture  
Connection  
Containment  
Shape

## ORDINAL

Position  
Density (Value)  
Color Sat  
Color Hue  
Texture  
Connection  
Containment  
Length  
Angle  
Slope  
Area (Size)  
Volume  
Shape

## NOMINAL

Position  
Color Hue  
Texture  
Connection  
Containment  
Density (Value)  
Color Sat  
Shape  
Length  
Angle  
Slope  
Area  
Volume

# Administrivia



# A3: Interactive Prototype

Create an interactive visualization. Choose a driving question for a dataset and develop an appropriate visualization + interaction techniques, then deploy your visualization on the web.

Due by *11:59pm* on **Monday, October 30.**

Work in project teams of 3-4 people.

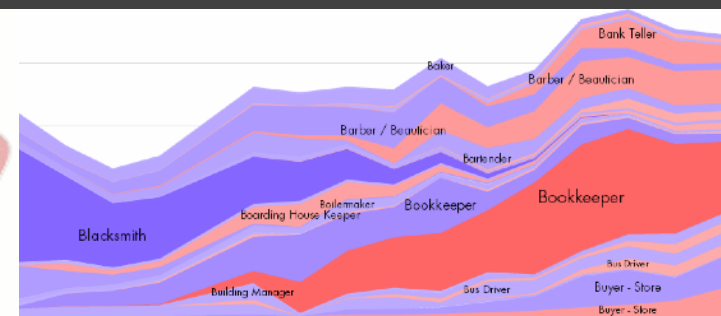
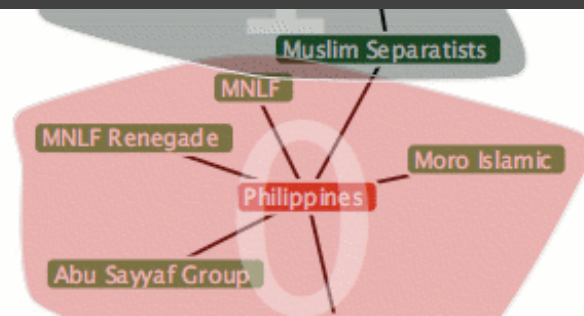

# Pre-Attentive Processing

# How Many 3's?

1281768756138976546984506985604982826762  
9809858458224509856458945098450980943585  
9091030209905959595772564675050678904567  
8845789809821677654876364908560912949686

[based on a slide from J. Stasko]

# How Many 3's?

1281768756138976546984506985604982826762  
9809858458224509856458945098450980943585  
9091030209905959595772564675050678904567  
8845789809821677654876364908560912949686

[based on a slide from J. Stasko]

# Visual Pop-Out: Color

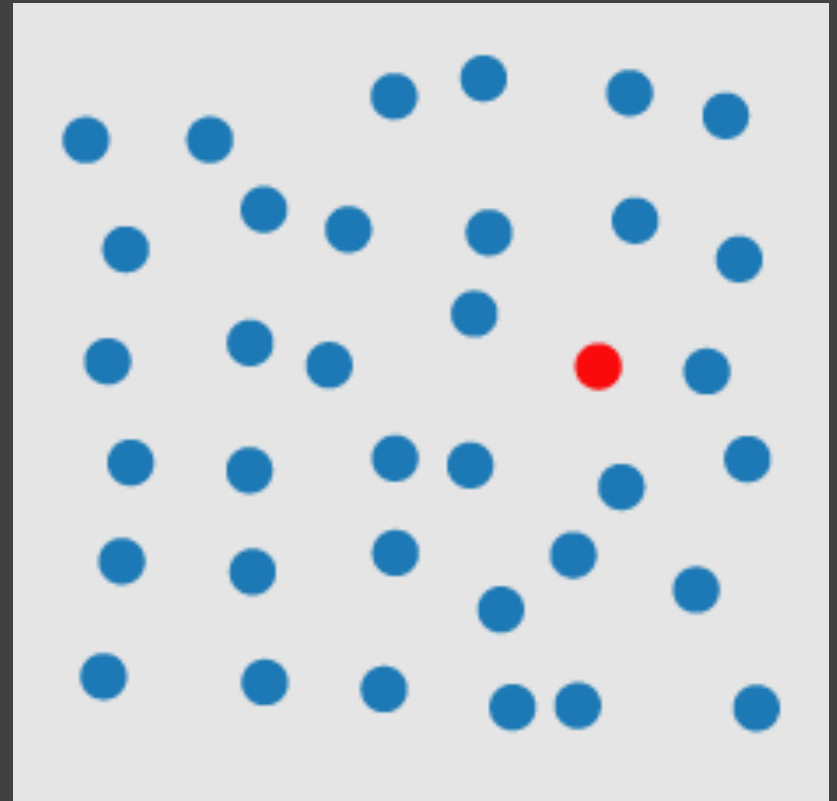
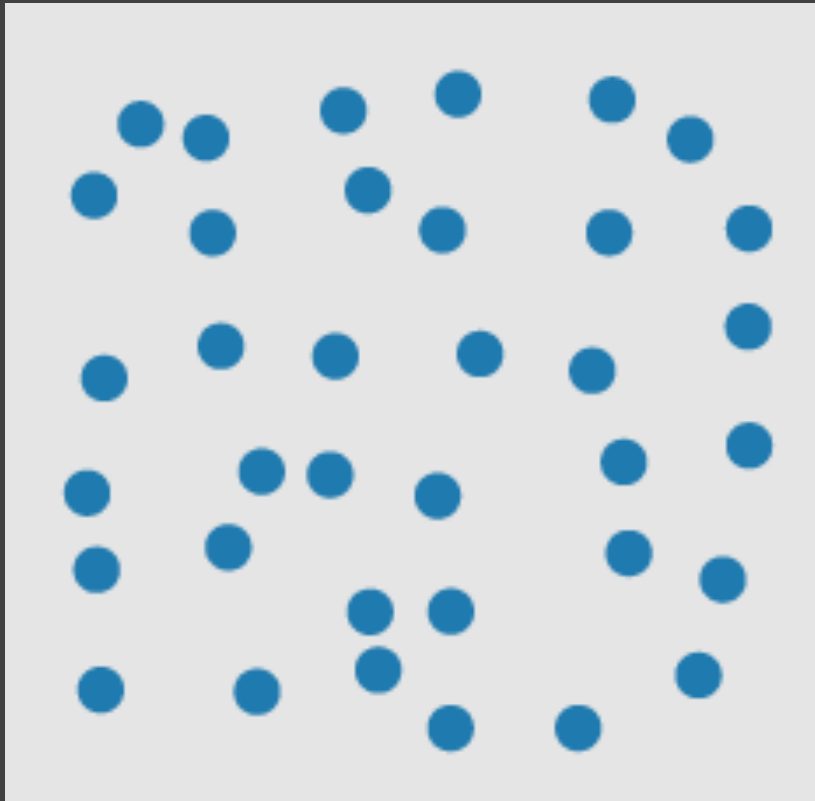

<http://www.csc.ncsu.edu/faculty/healey/PP/index.html>

# Visual Pop-Out: Shape

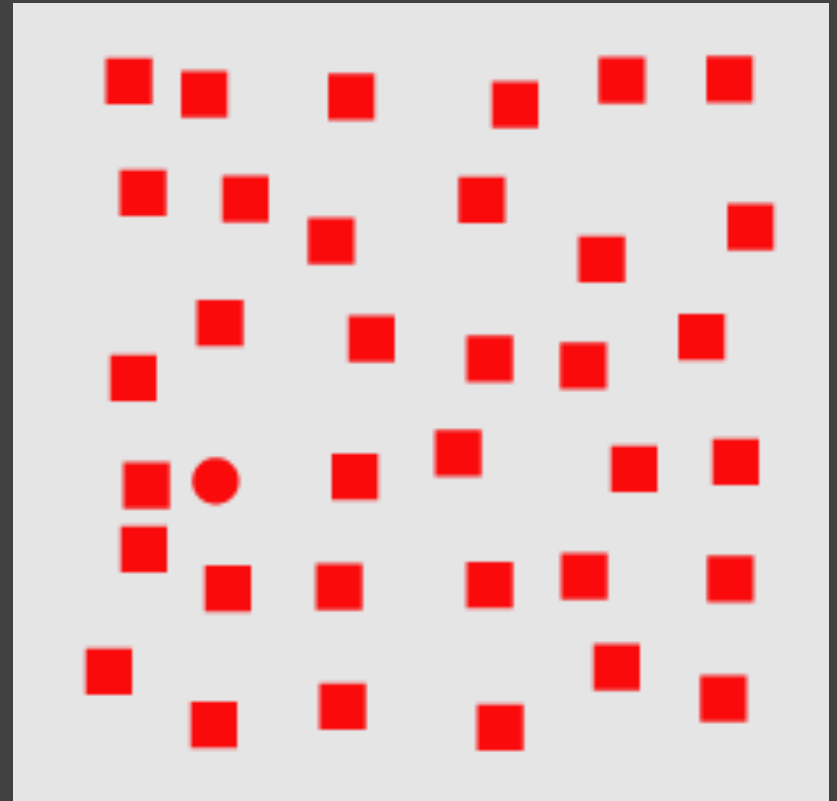
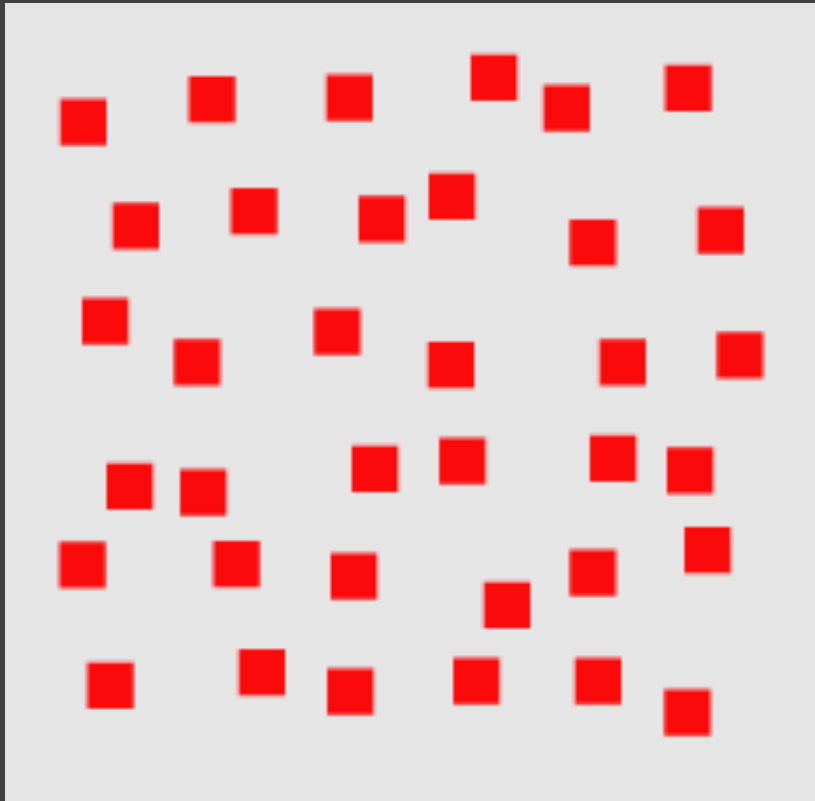

<http://www.csc.ncsu.edu/faculty/healey/PP/index.html>

# Feature Conjunctions

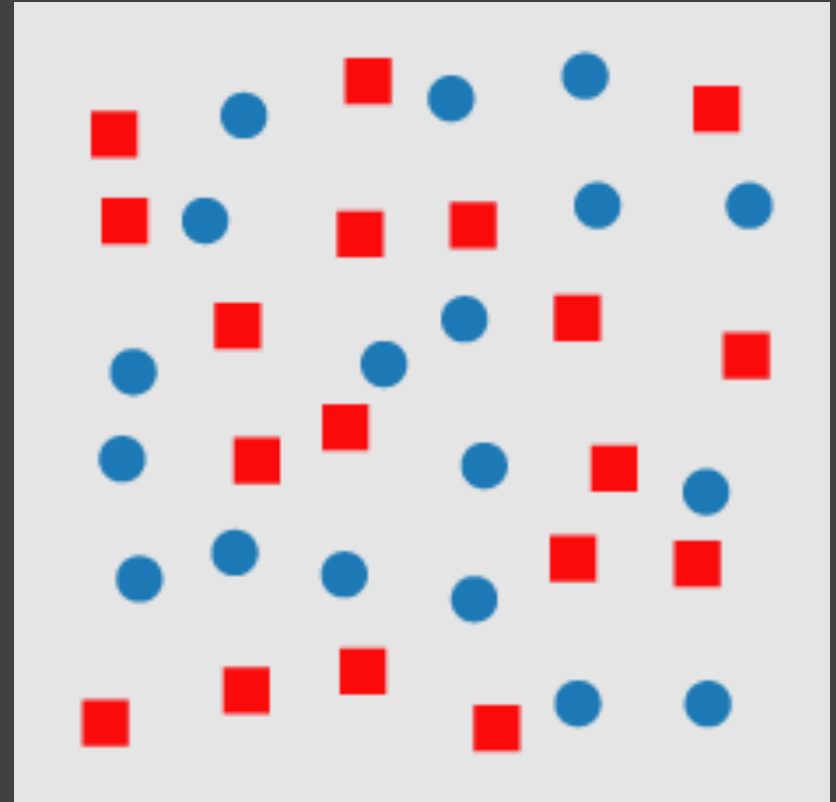
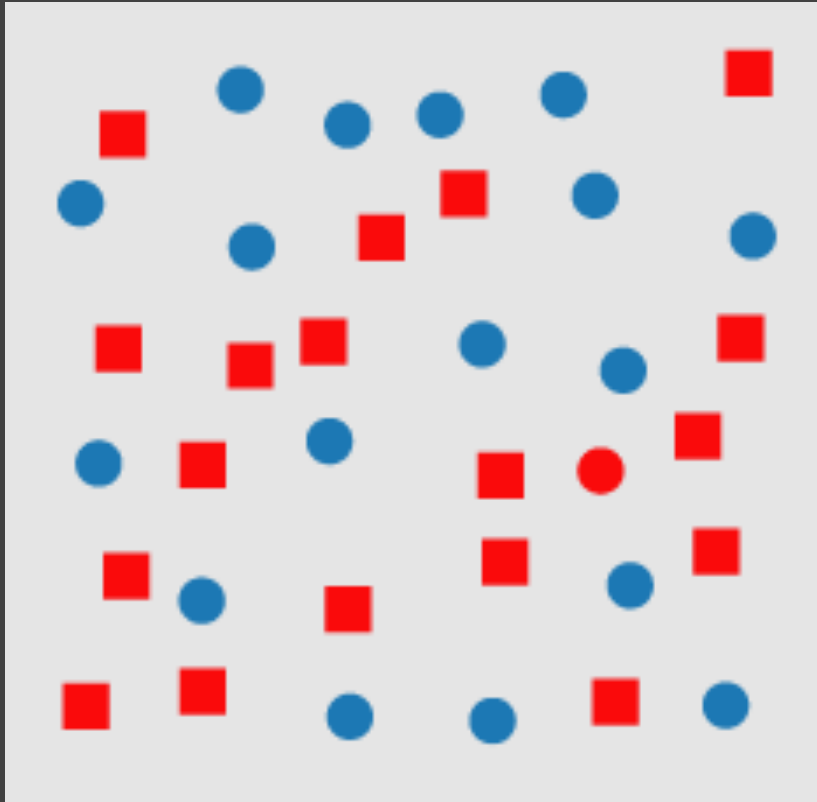

# Pre-Attentive Features

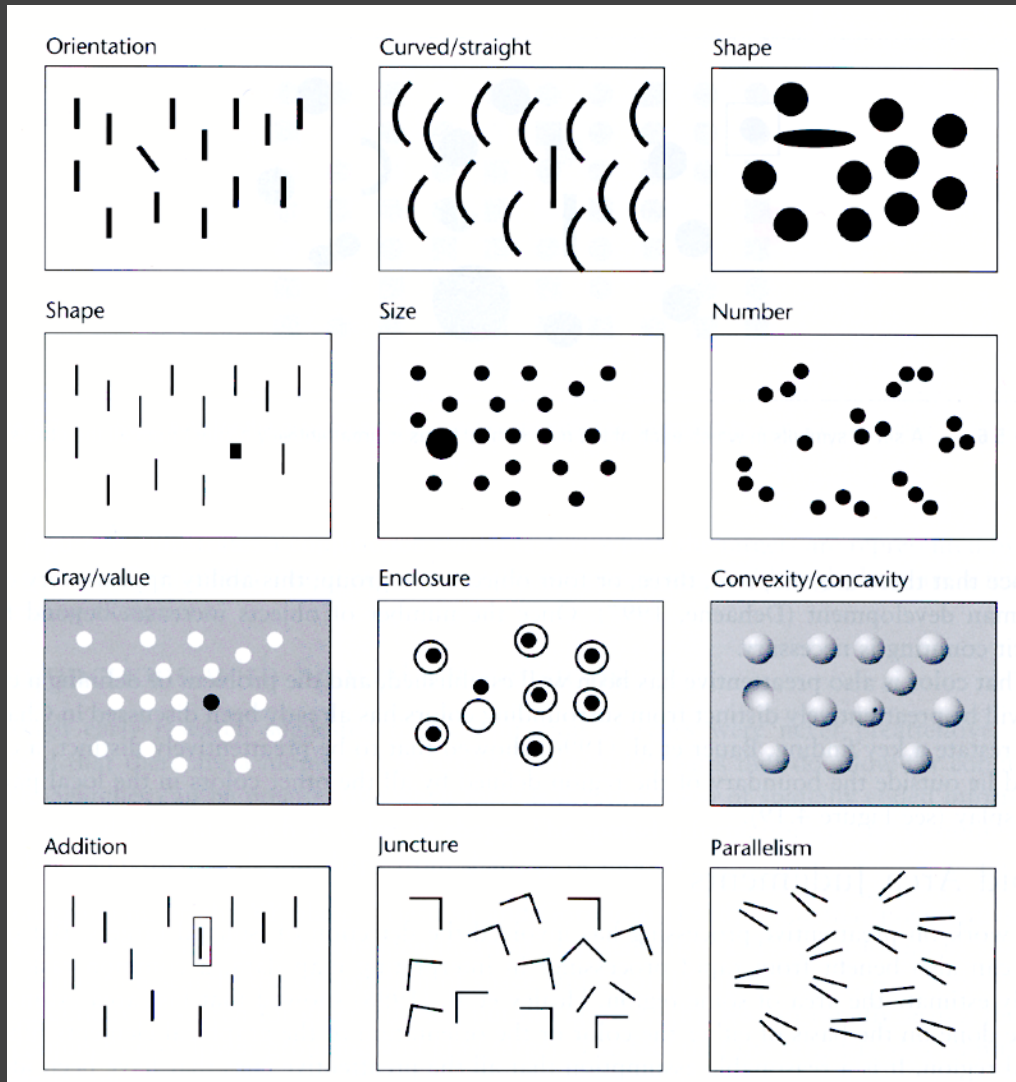

[Information Visualization.  
Figure 5.5 Ware 04]



# More Pre-Attentive Features

Line (blob) orientation	Julesz & Bergen [1983]; Wolfe et al. [1992]
Length	Triesman & Gormican [1988]
Width	Julesz [1985]
Size	Triesman & Gelade [1980]
Curvature	Triesman & Gormican [1988]
Number	Julesz [1985]; Trick & Pylyshyn [1994]
Terminators	Julesz & Bergen [1983]
Intersection	Julesz & Bergen [1983]
Closure	Enns [1986]; Triesman & Souther [1985]
Colour (hue)	Nagy & Sanchez [1990, 1992]; D'Zmura [1991]; Kawai et al. [1995]; Bauer et al. [1996]
Intensity	Beck et al. [1983]; Triesman & Gormican [1988]
Flicker	Julesz [1971]
Direction of motion	Nakayama & Silverman [1986]; Driver & McLeod [1992]
Binocular lustre	Wolfe & Franzel [1988]
Stereoscopic depth	Nakayama & Silverman [1986]
3-D depth cues	Enns [1990]
Lighting direction	Enns [1990]

# Pre-Attentive Conjunctions

**Spatial conjunctions** are often pre-attentive

Motion and 3D disparity

Motion and color

Motion and shape

3D disparity and color

3D disparity and shape

Most conjunctions are not pre-attentive

# Feature Integration Theory

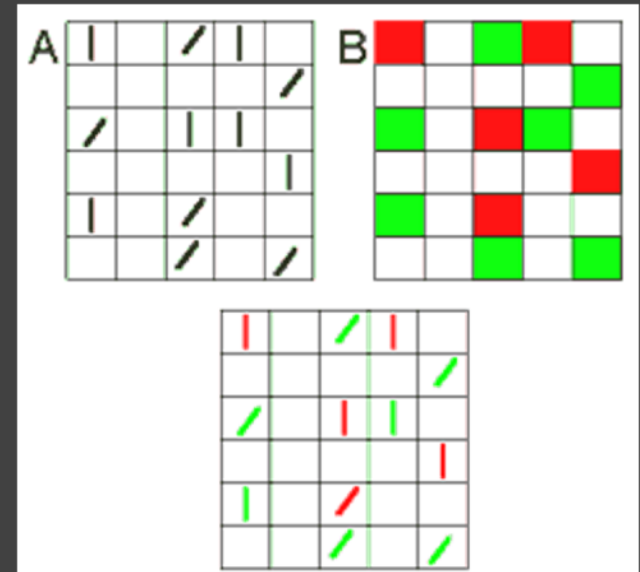
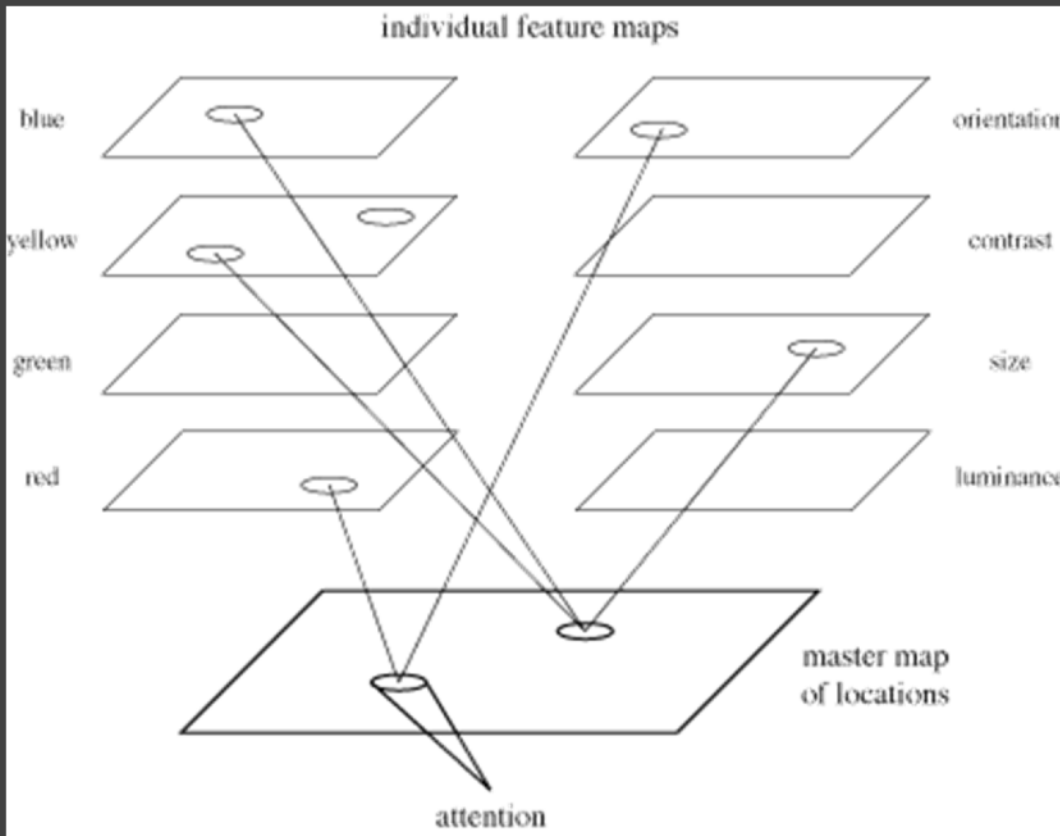

Feature maps for orientation & color [Green]

Treisman's feature integration model [Healey 04]

# Multiple Attributes

# One-Dimensional: Lightness



White



White



White



Black



Black



Black



White



White



Black



White

# One-Dimensional: Shape



Square



Circle



Circle



Square



Circle



Circle



Circle



Square



Circle



Circle

# Redundant: Shape & Lightness



Circle



Square



Square



Circle



Square



Circle



Square



Square



Square



Circle

# Orthogonal: Shape & Lightness



Circle



Square



Square



Circle



Square



# Speeded Classification

## Redundancy Gain

Facilitation in reading one dimension when the other provides redundant information

## Filtering Interference

Difficulty in ignoring one dimension while attending to the other

# Speeded Classification

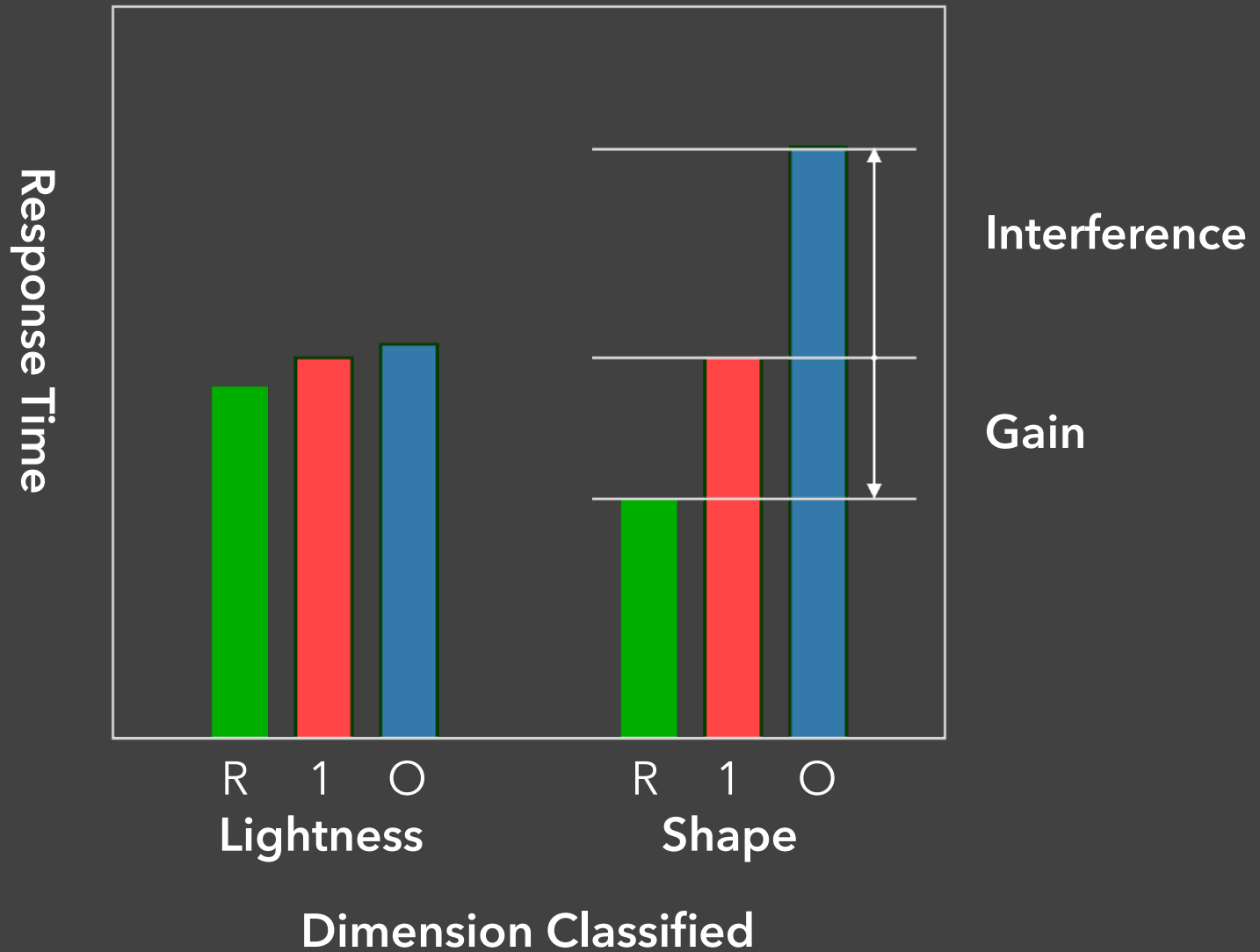

# Types of Perceptual Dimensions

## **Integral**

Filtering interference and redundancy gain

## **Separable**

No interference or gain

## **Asymmetric**

One dim separable from other, not vice versa

*Example:* The Stroop effect – color naming is influenced by word identity, but word naming is not influenced by color

# Size and Value

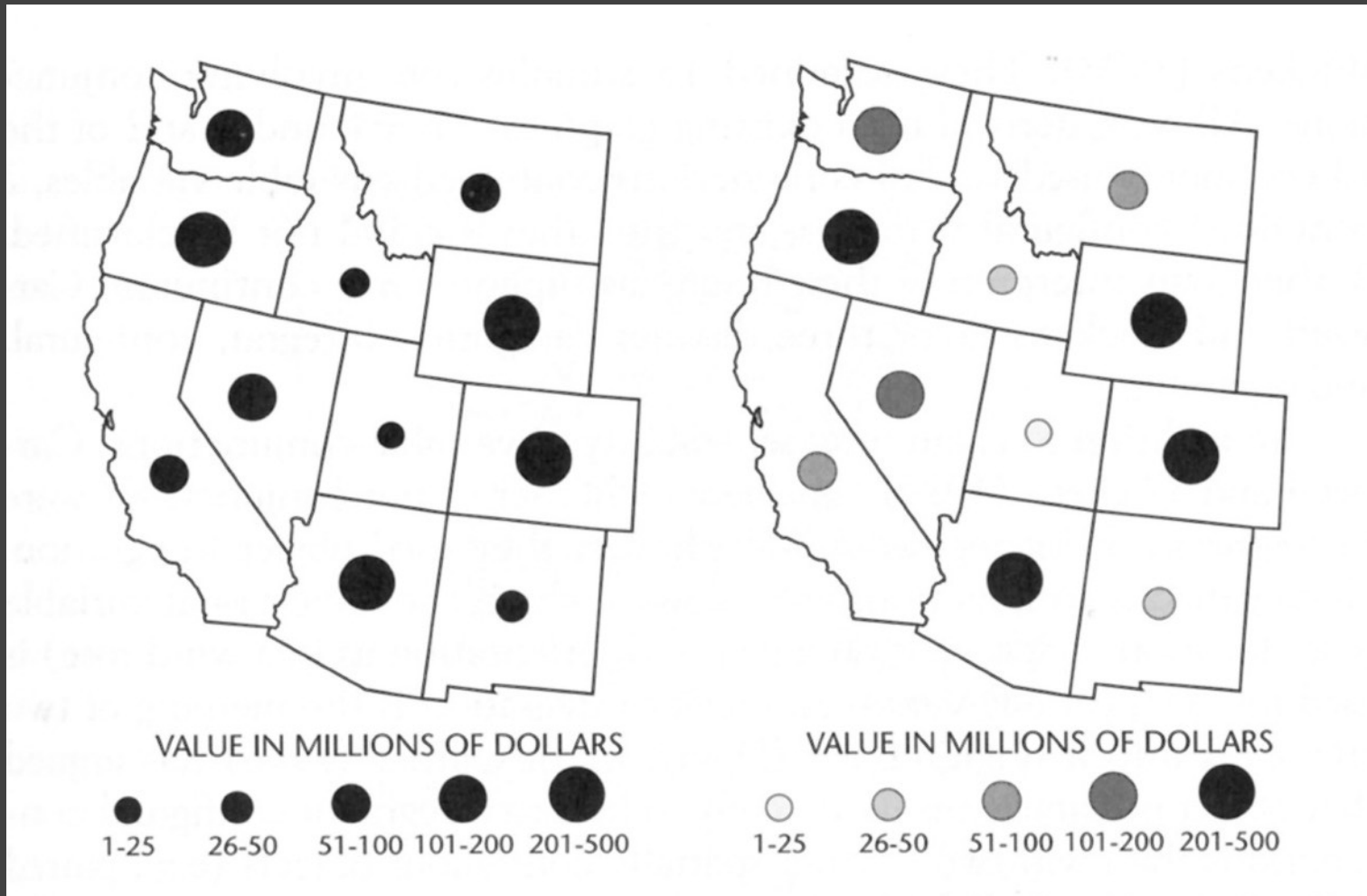

W. S. Dobson, Visual information processing and cartographic communication: The role of redundant stimulus dimensions, 1983 (reprinted in MacEachren, 1995)

# Orientation & Size

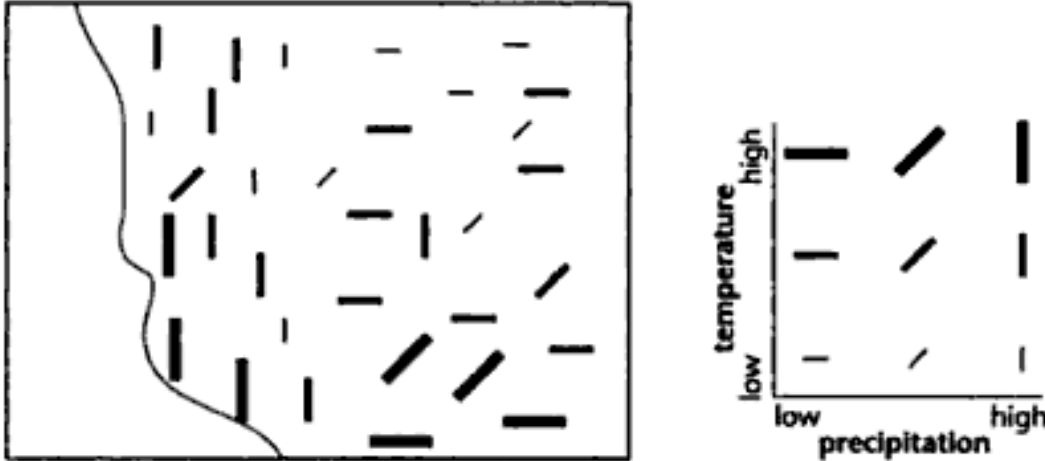

**FIGURE 3.36.** A map of temperature and precipitation using symbol size and orientation to represent data values on the two variables.

How well can you see temperature or precipitation?  
Is there a correlation between the two?

# Shape & Size

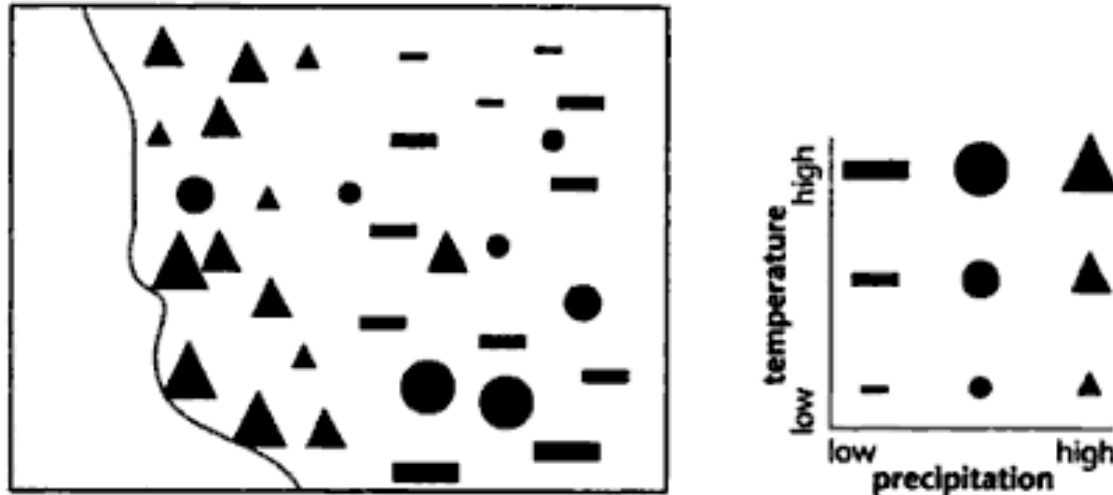

**FIGURE 3.40.** The bivariate temperature–precipitation map of Figure 3.36, this time using point symbols that vary in shape and size to represent the two quantities.

Easier to see one shape across multiple sizes than one size of across multiple shapes?

# Length & Length

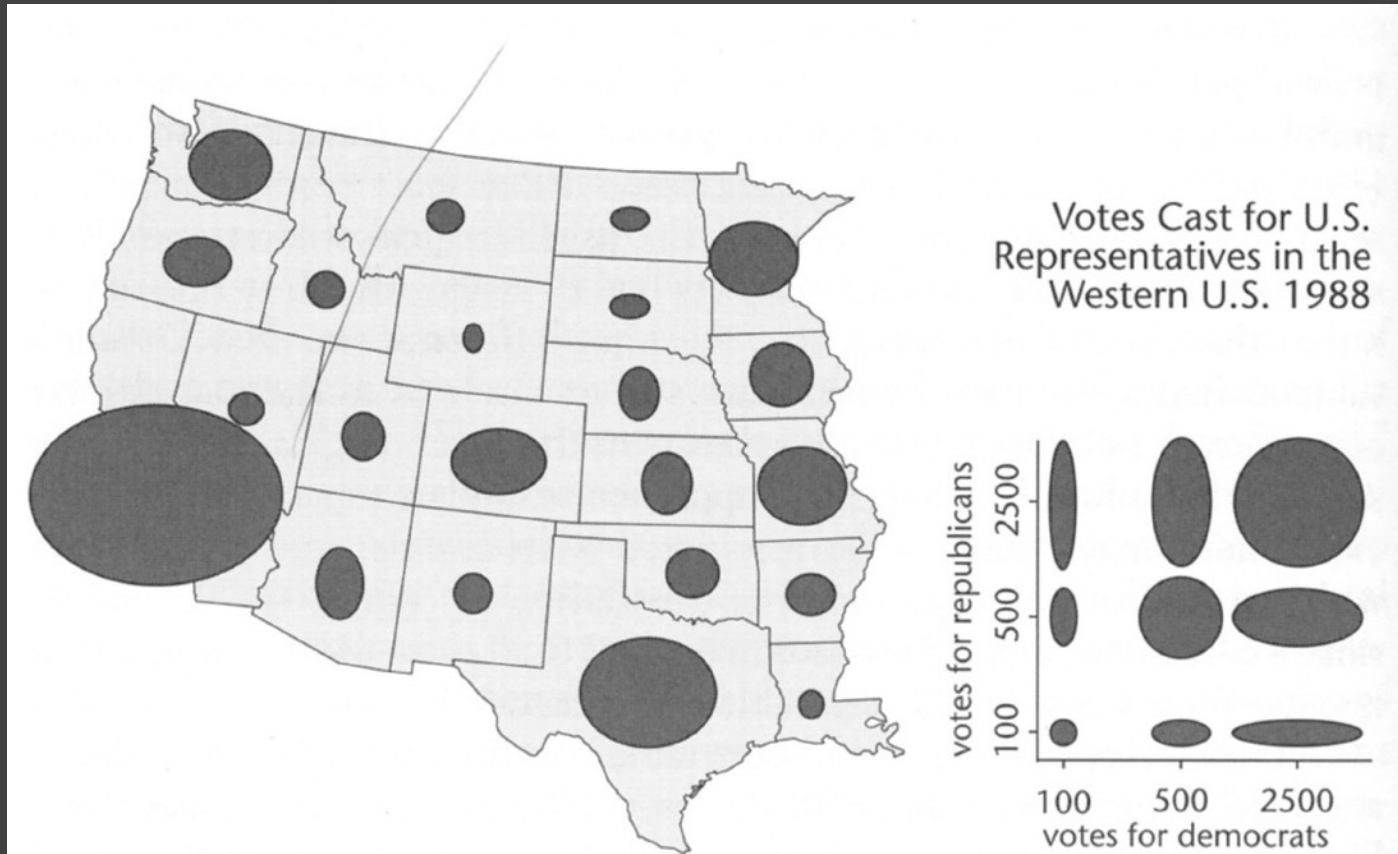
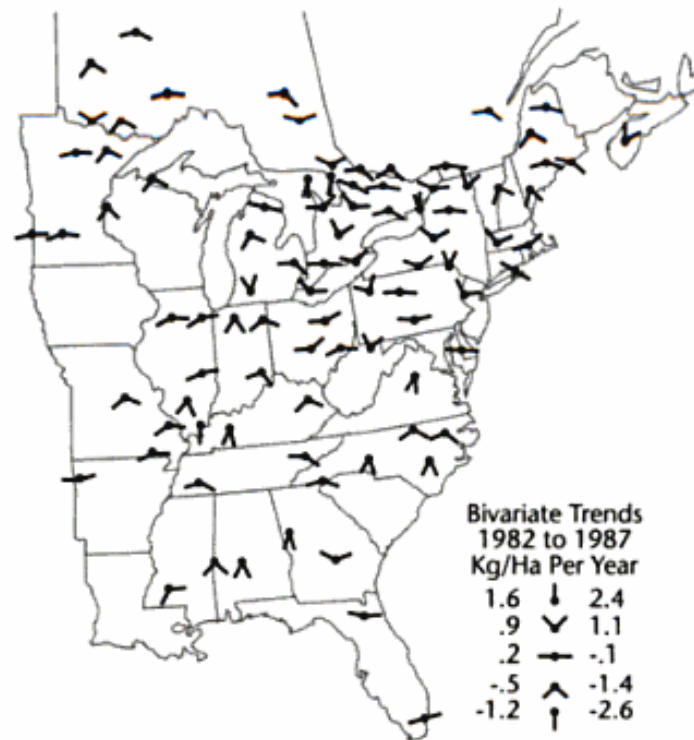

FIGURE 3.38. An example of the use of an ellipse as a map symbol in which the horizontal and vertical axes represent different (but presumably related) variables.

# Angle & Angle



**FIGURE 3.39.** Bivariate map of NO<sub>3</sub> and SO<sub>4</sub> trends. The original Carr et al. version of this map used a wheel with eight spokes, rather than a simple dot, as the center of each glyph. When large enough, this added feature facilitates judgment of specific values. After Carr et al. (1992, Fig. 7a, p. 234). Adapted by permission of the American Congress on Surveying and Mapping.



# Summary of Integral & Separable

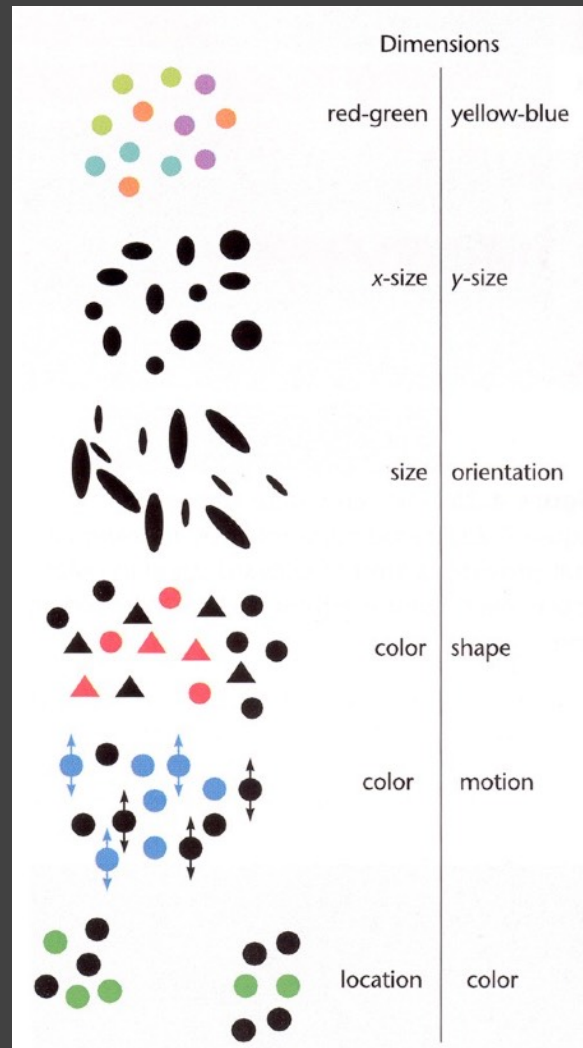

Integral

Separable

[Figure 5.25,  
Color Plate 10,  
Ware 2000]

# Set

Each card has **4 features**:

Color

Symbol

Number

Shading/Texture

A set consists of 3 cards in which each feature is the **SAME** or **DIFFERENT** on each card.

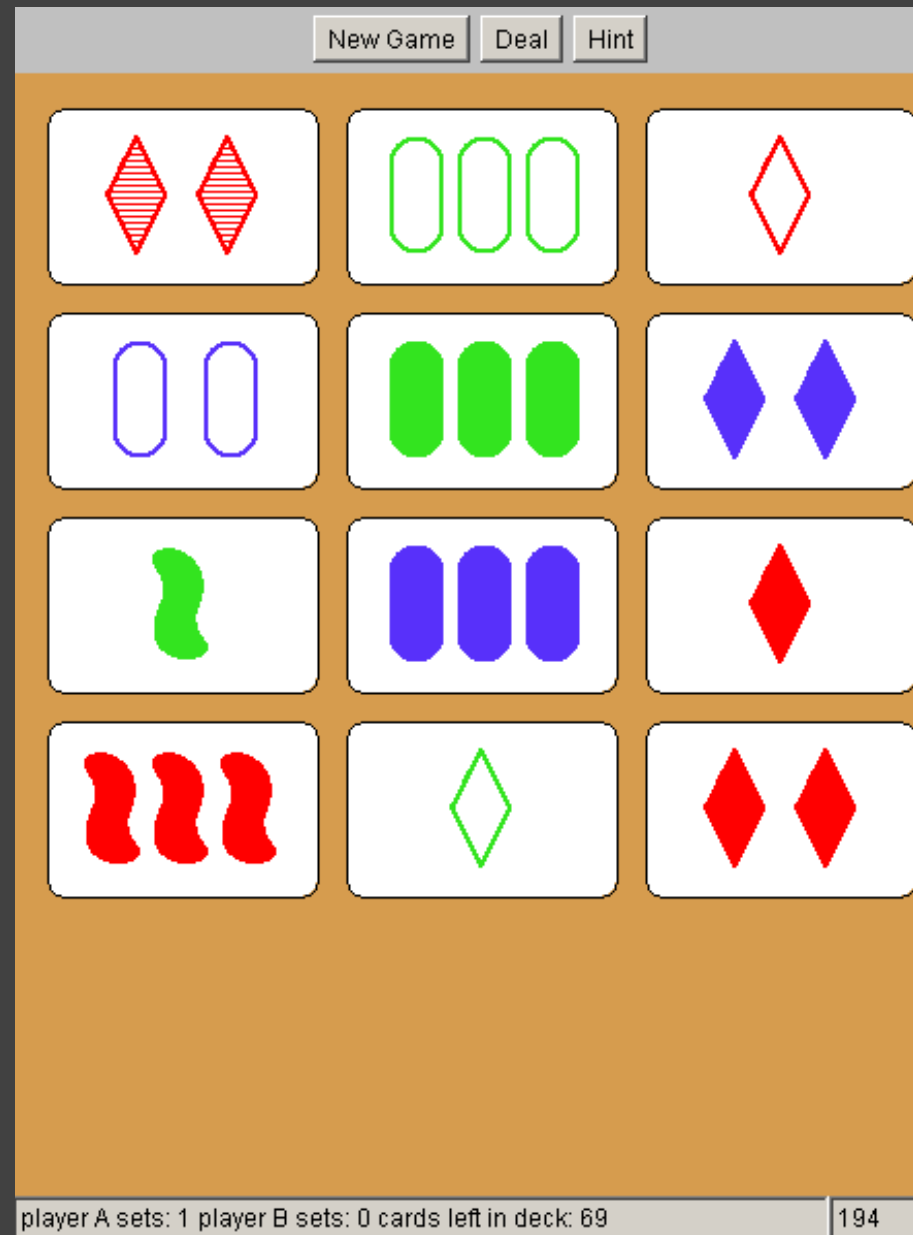

# Gestalt Grouping

# Gestalt Principles

Figure/Ground

Proximity

Similarity

Symmetry

Connectedness

Continuity

Closure

Common Fate

Transparency

# Figure/Ground



Ambiguous

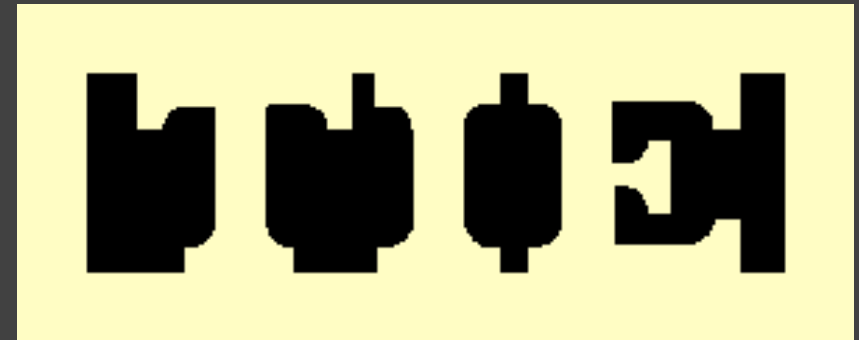

Principle of surroundedness

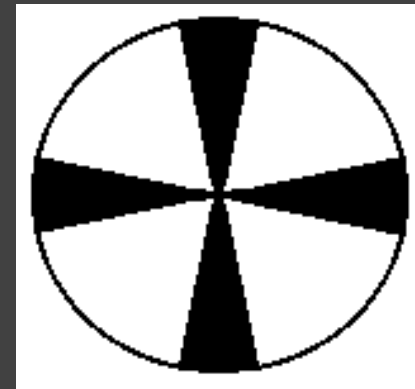

Principle of relative size

# Figure/Ground



Ambiguous



Unambiguous (?)

# Proximity

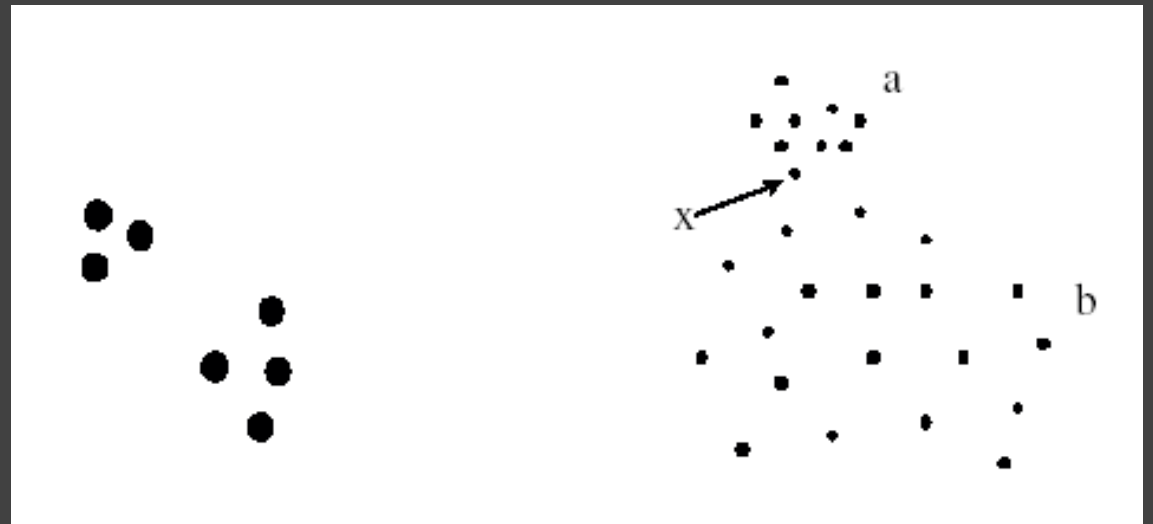
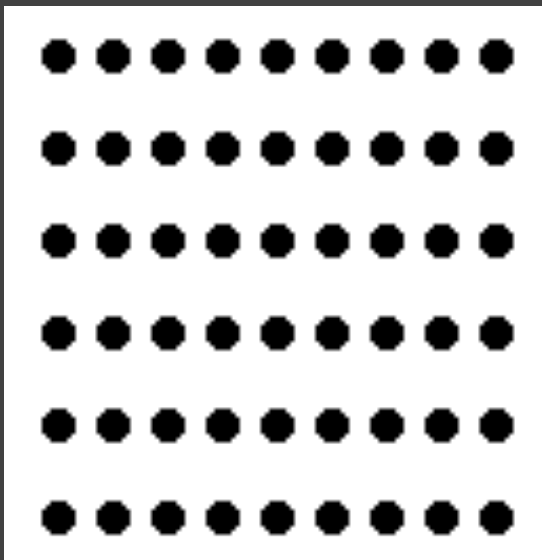
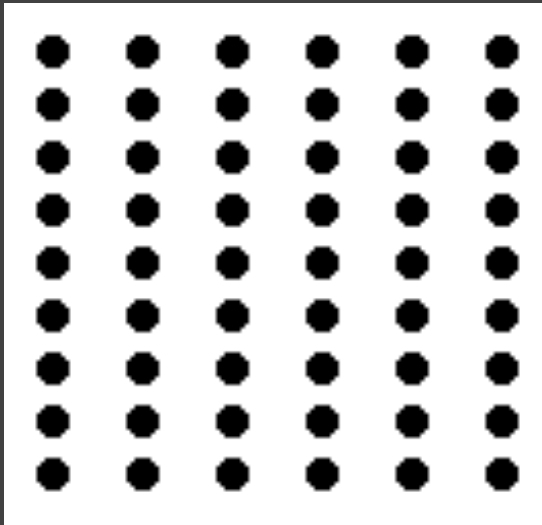

[Ware 00]

# Similarity

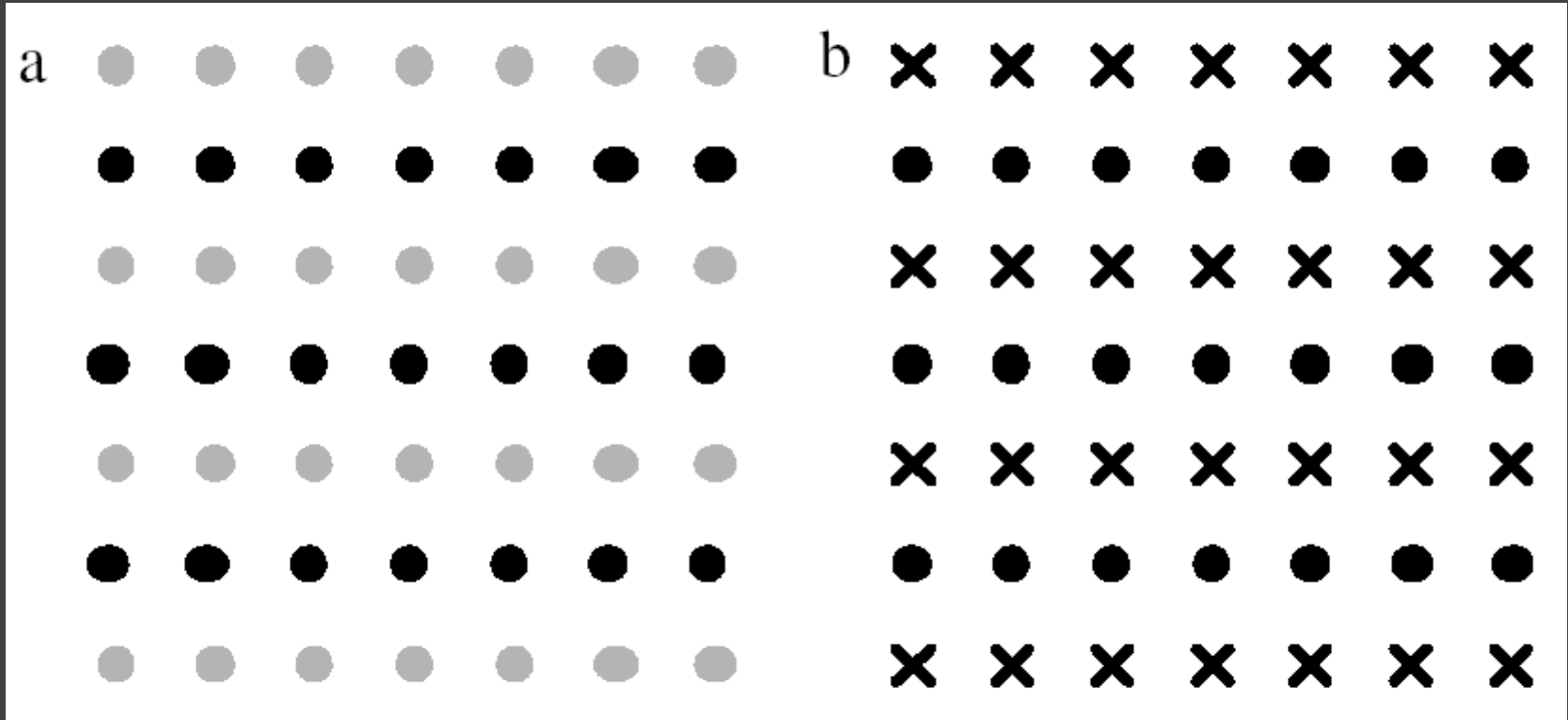

Rows dominate due to similarity [from Ware 04]



# Symmetry

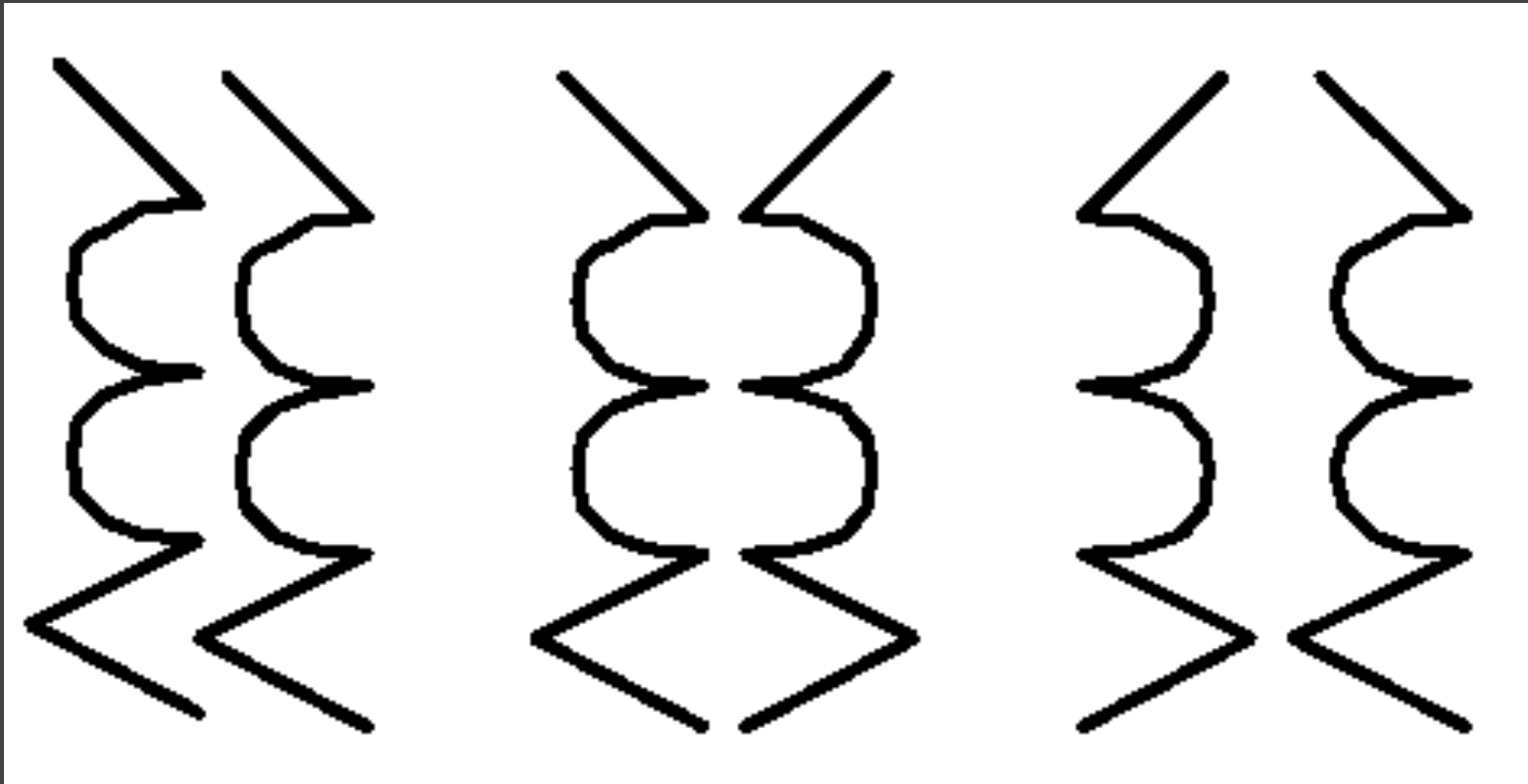

Bilateral symmetry gives strong sense of figure [from Ware 04]

# Connectedness

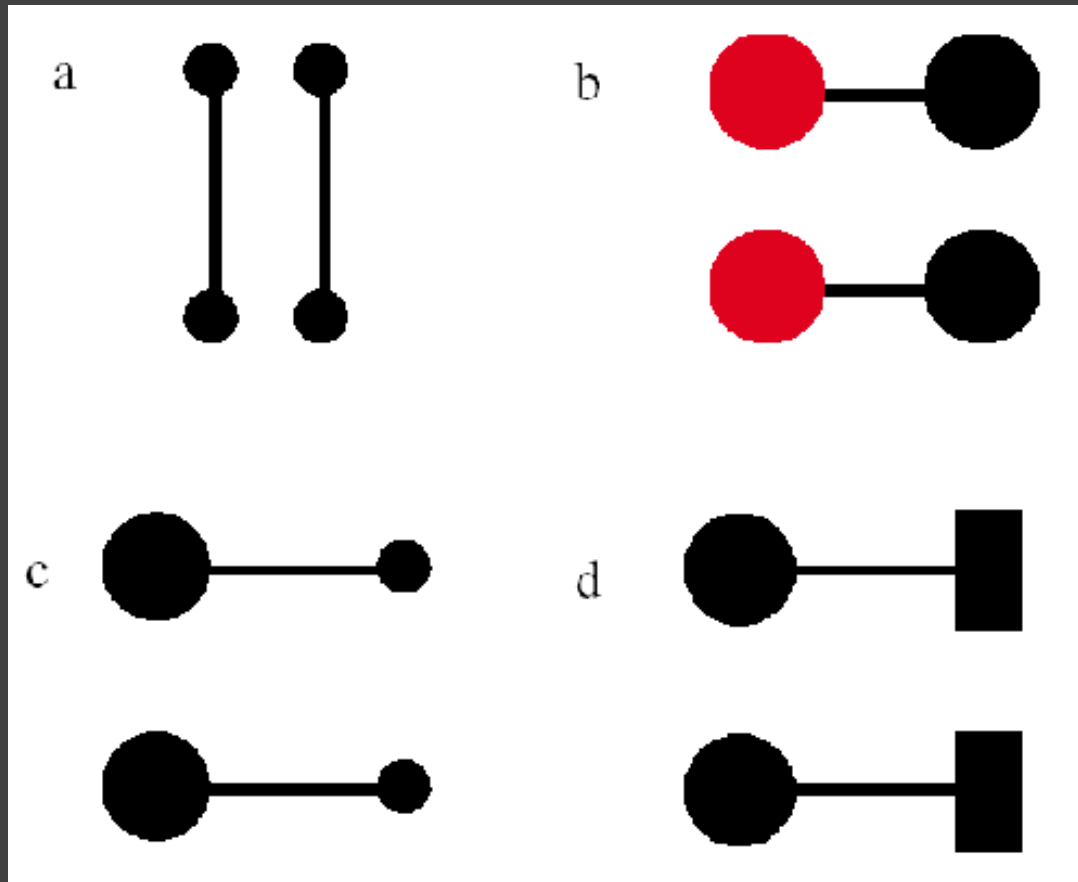

Connectedness overrules proximity, size, color shape [from Ware 04]

# Continuity

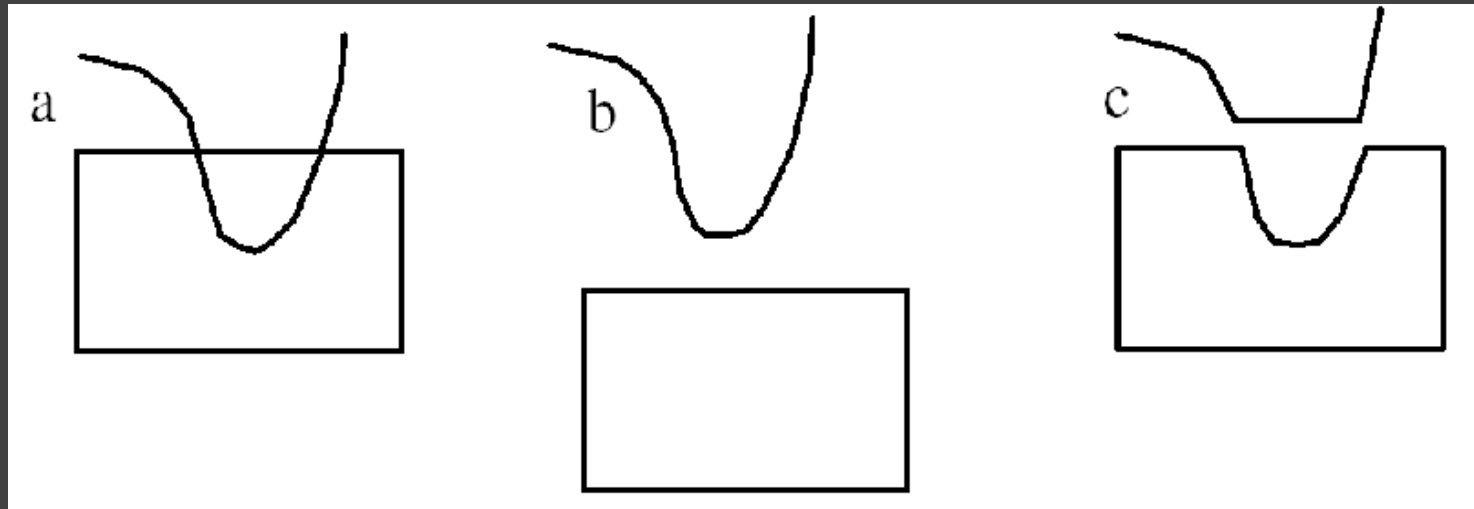

We prefer smooth not abrupt changes [from Ware 04]

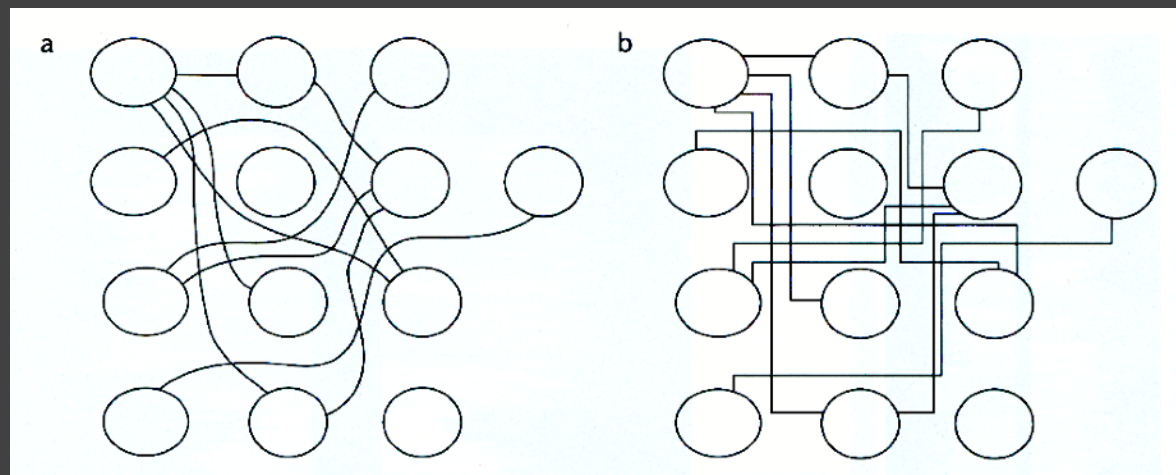

Connections are clearer with smooth contours [from Ware 04]

# Continuity: Vector Fields

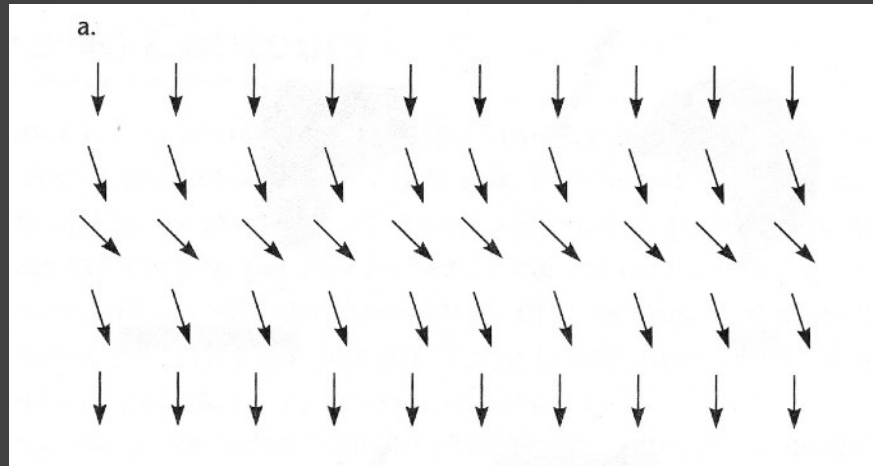

# Closure

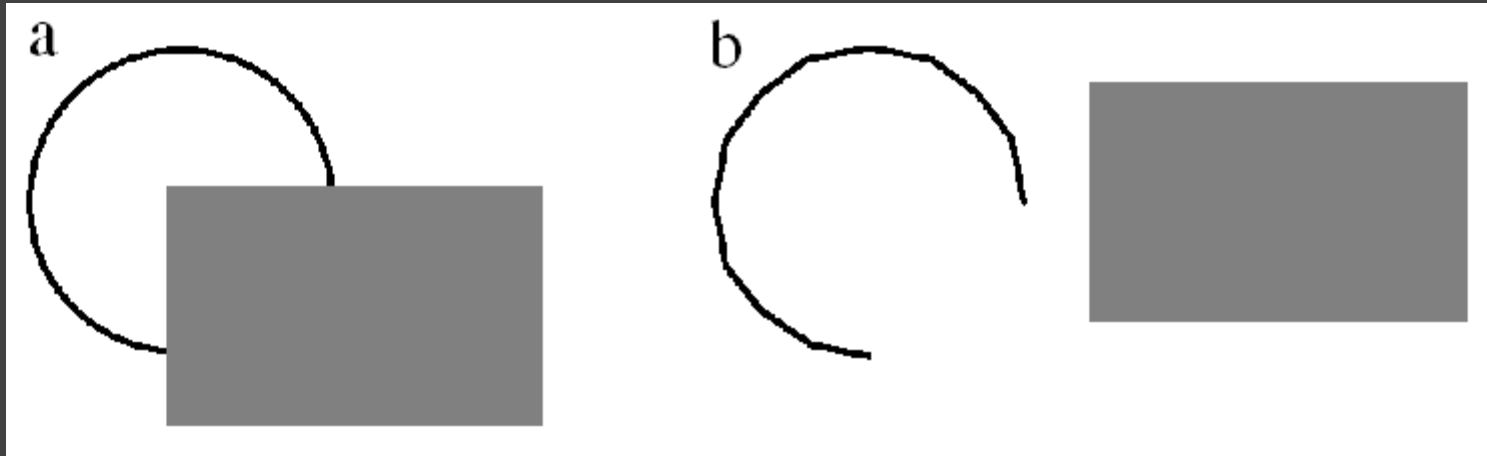

We see a circle behind a rectangle, not a broken circle [from Ware 04]

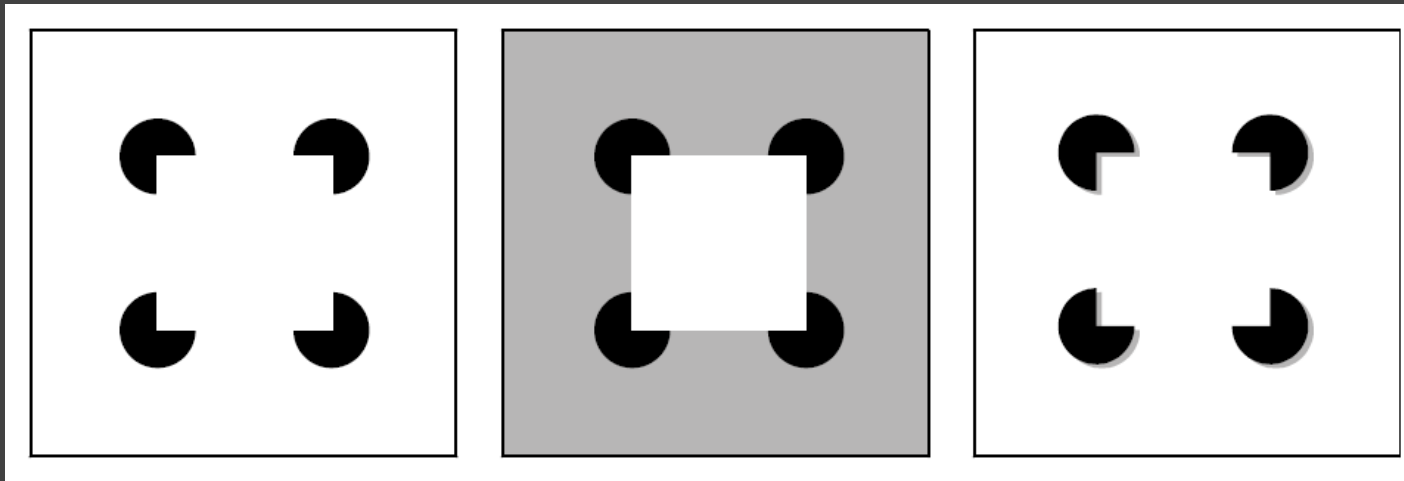

Illusory contours [from Durand 02]

# Common Fate



Dots moving together are grouped

# Transparency



Requires continuity and proper color correspondence [from Ware 04]

# Layering



# Layering: Gridlines

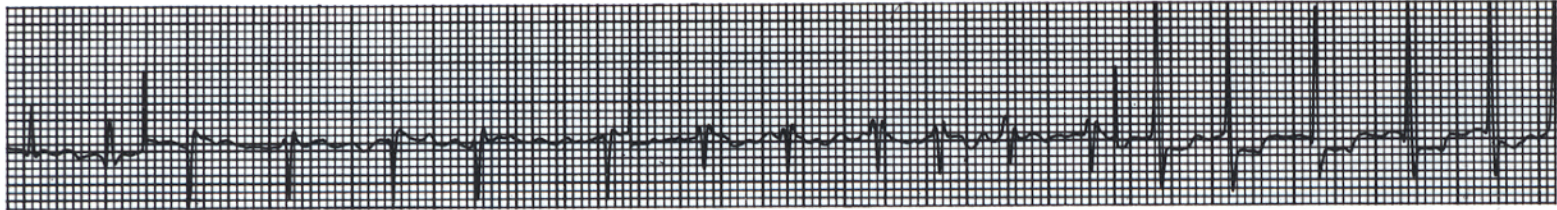

Signal and background compete above, as an electrocardiogram trace-line becomes caught up in a thick grid. Below, the screened-down grid stays behind traces from each of 12 monitoring leads:<sup>4</sup>

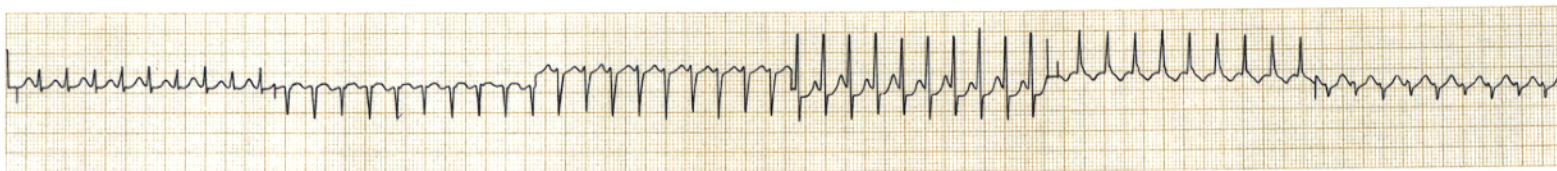

# Layering: Gridlines

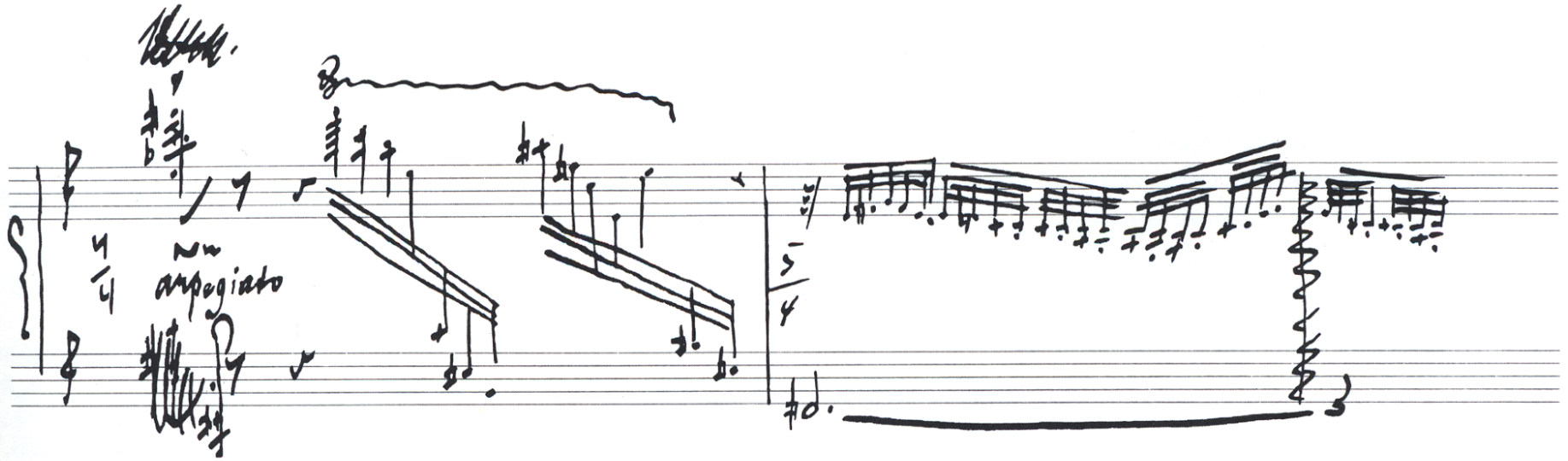
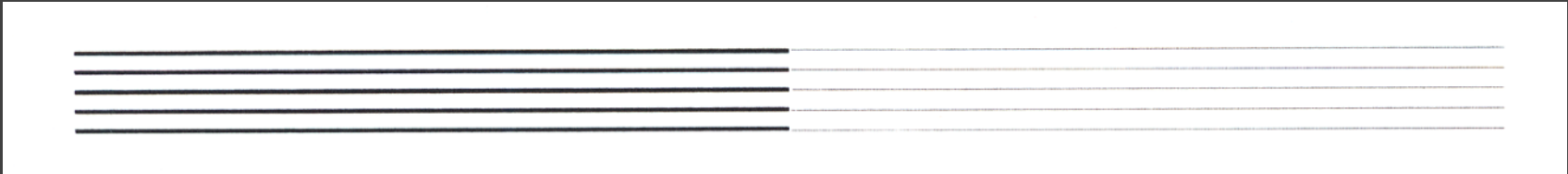

Stravinsky score [from Tufte 90]

# Setting Gridline Contrast

How light can gridlines be and remain visible?  
How dark can gridlines be and not distract?

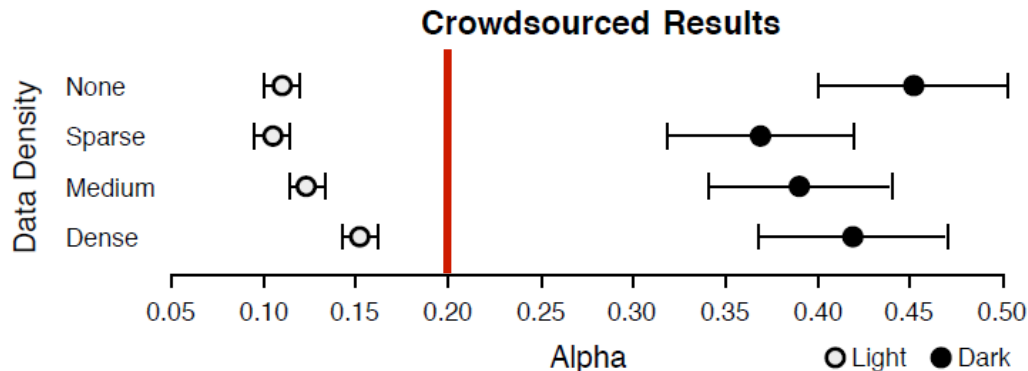
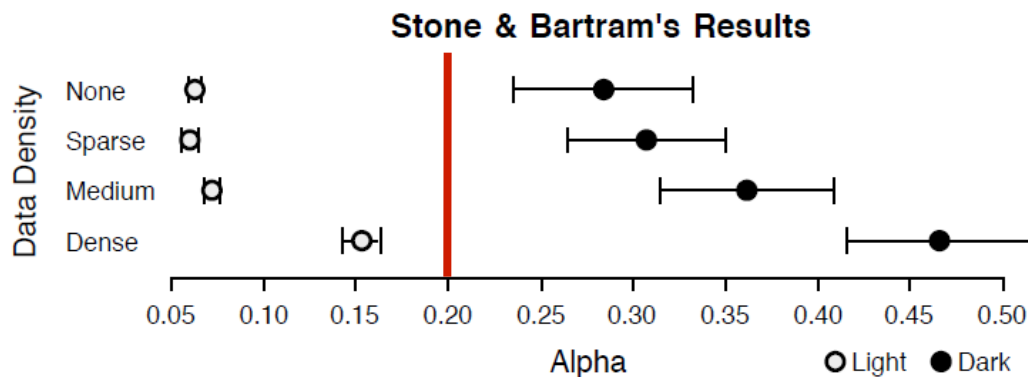

Safe setting:  
20% Alpha

[Stone & Bartram 2009]

[Heer & Bostock 2010]

# Change Blindness

# Change Blindness



# Change Blindness



# Change Blindness



# Change Blindness





# Change Blindness



[Example from Palmer 99, originally due to Rock]

# Demonstrations

<http://www.psych.ubc.ca/~rensink/flicker/download/>

<http://www.youtube.com/watch?v=Ahg6qcgoy4>

# Summary

Choosing effective visual encodings requires knowledge of visual perception.

## **Visual features/attributes**

Individual attributes often pre-attentive

Multiple attributes may be separable or integral

**Gestalt principles** provide high-level guidelines

We don't always see everything that is there!