



CSE 417

Algorithms and Complexity

Autumn 2023

Lecture 24

Network Flow, Part 1

Announcements

- Homework 8, Due Wednesday, Nov 29
- Homework 9, Due Friday, Dec 8

Network Flow

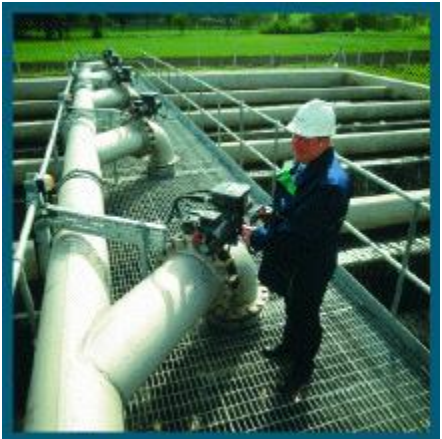

Outline

- Network flow definitions
- Flow examples
- Augmenting Paths
- Residual Graph
- Ford Fulkerson Algorithm
- Cuts
- Maxflow-MinCut Theorem

Network Flow Definitions

- Capacity
- Source, Sink
- Capacity Condition
- Conservation Condition
- Value of a flow

Flow Example

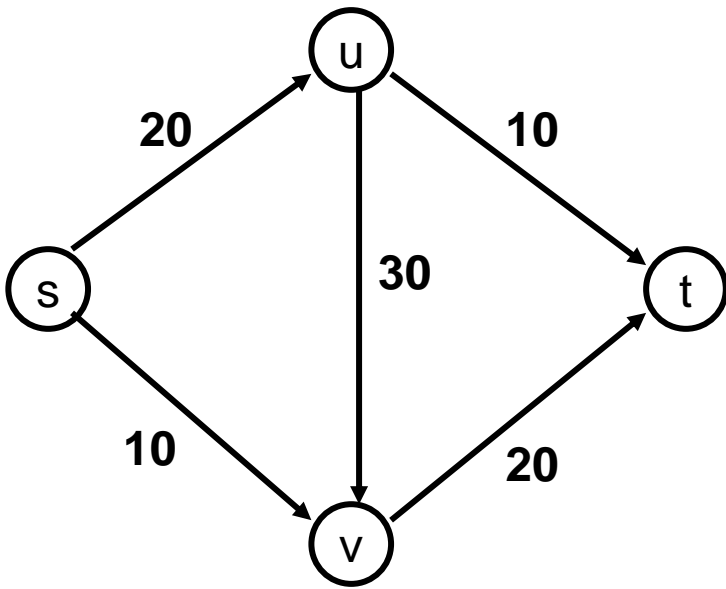

Network Flow Definitions

- Flowgraph: Directed graph with distinguished vertices s (source) and t (sink)
- Capacities on the edges, $c(e) \geq 0$
- Problem, assign flows $f(e)$ to the edges such that:
 - $0 \leq f(e) \leq c(e)$
 - Flow is conserved at vertices other than s and t
 - Flow conservation: flow going into a vertex equals the flow going out
 - The flow leaving the source is as large as possible

Flow Example

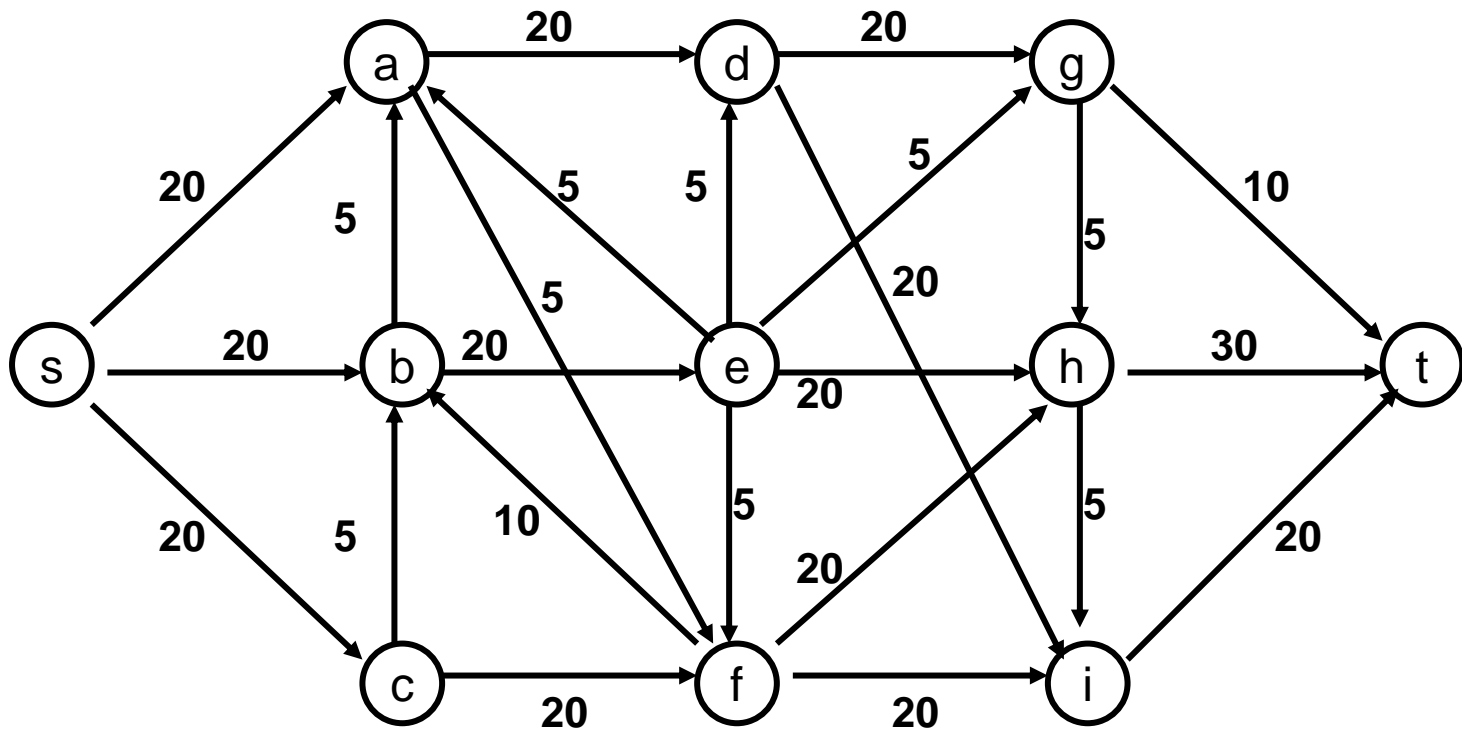

Find a maximum flow

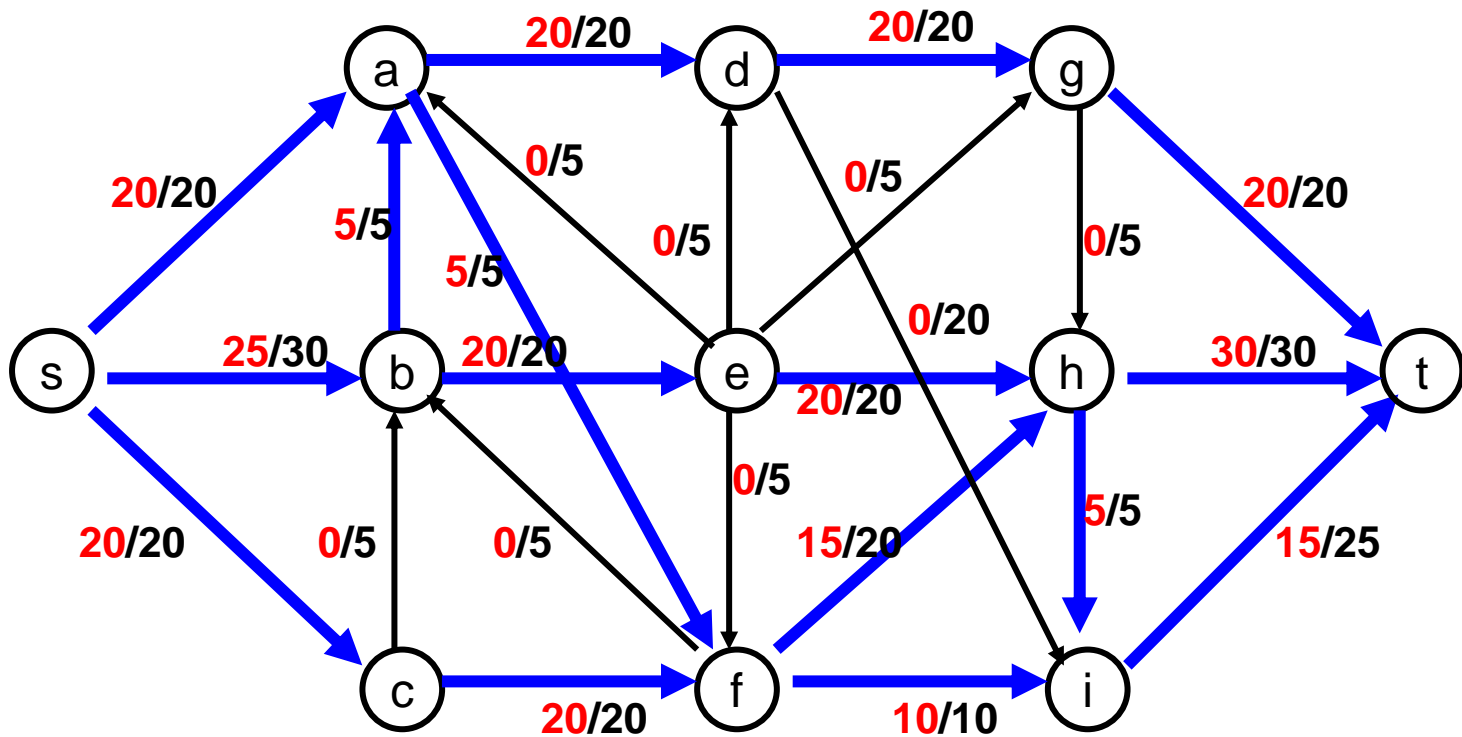

Flow Example

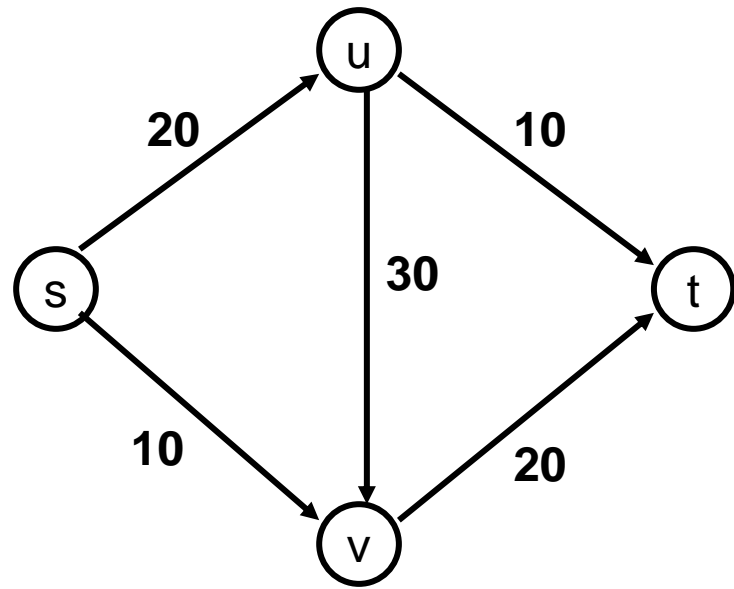
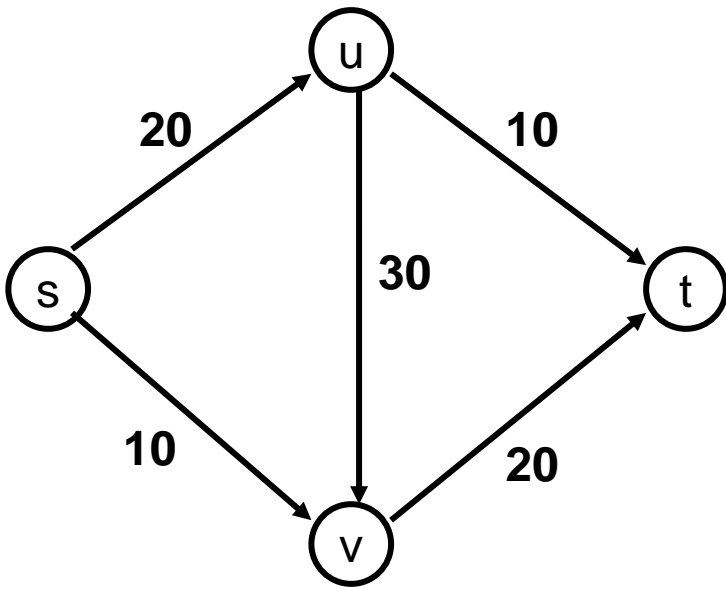

Residual Graph

- Flow graph showing the remaining capacity
- Flow graph G , Residual Graph G_R
 - G : edge e from u to v with capacity c and flow f
 - G_R : edge e' from u to v with capacity $c - f$
 - G_R : edge e'' from v to u with capacity f

Flow assignment and the residual graph

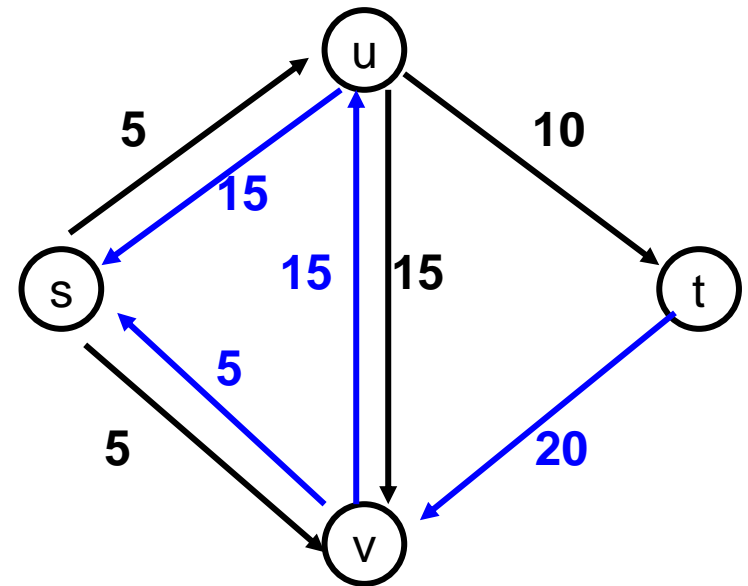
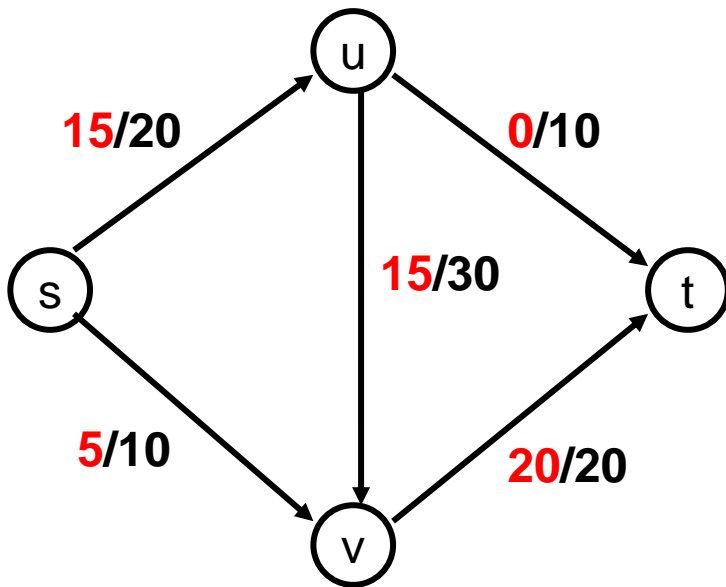

Augmenting Path Algorithm

- Augmenting path
 - Vertices v_1, v_2, \dots, v_k
 - $v_1 = s, v_k = t$
 - Possible to add b units of flow between v_j and v_{j+1} for $j = 1 \dots k-1$

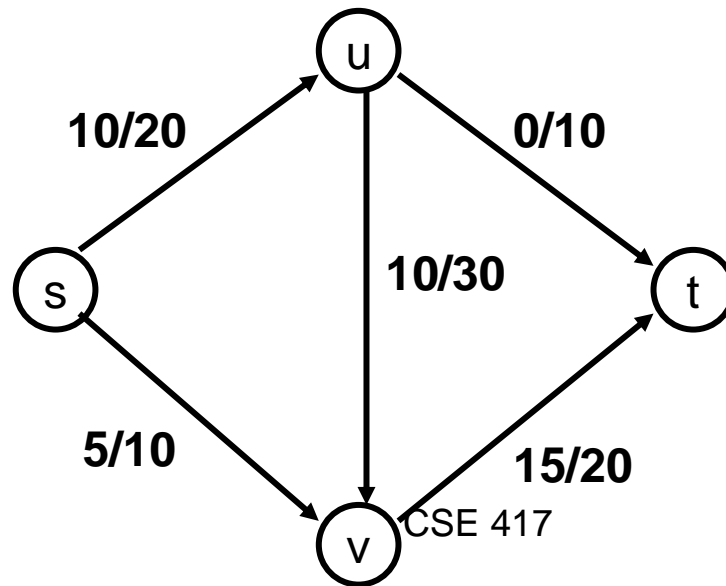

Build the residual graph

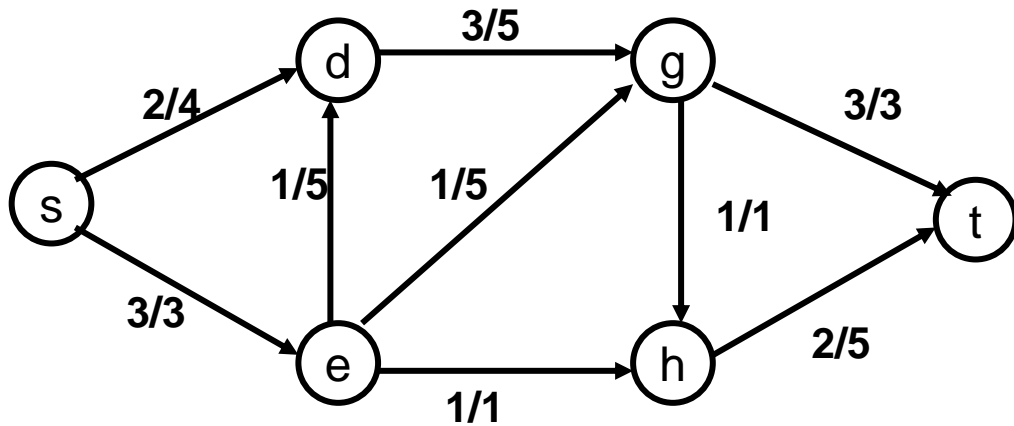

Residual graph:

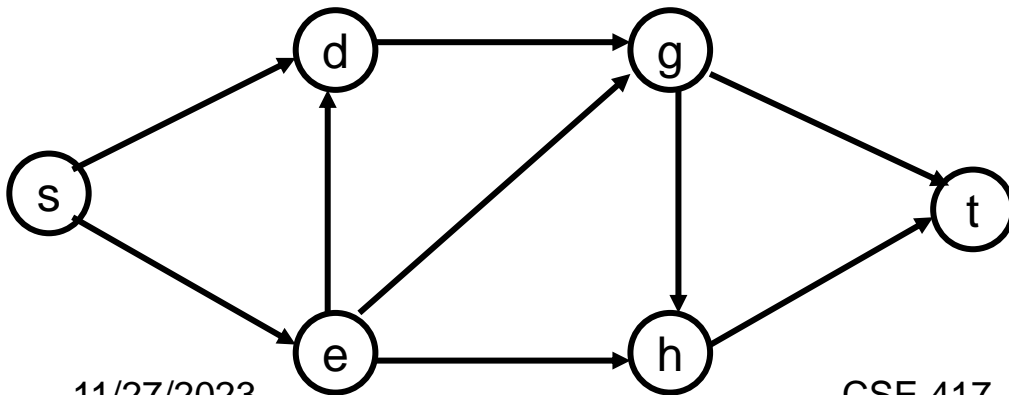

Find two augmenting paths

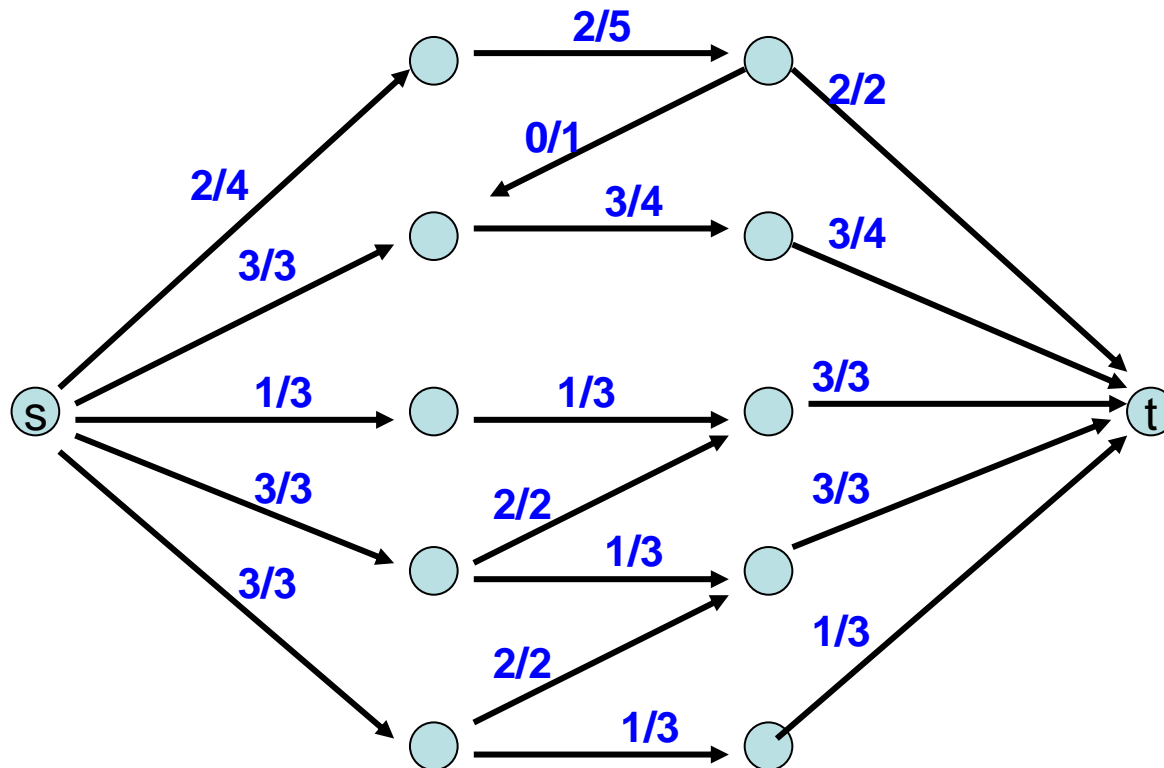

Augmenting Path Lemma

- Let $P = v_1, v_2, \dots, v_k$ be a path from s to t with minimum capacity b in the residual graph.
- b units of flow can be added along the path P in the flow graph.

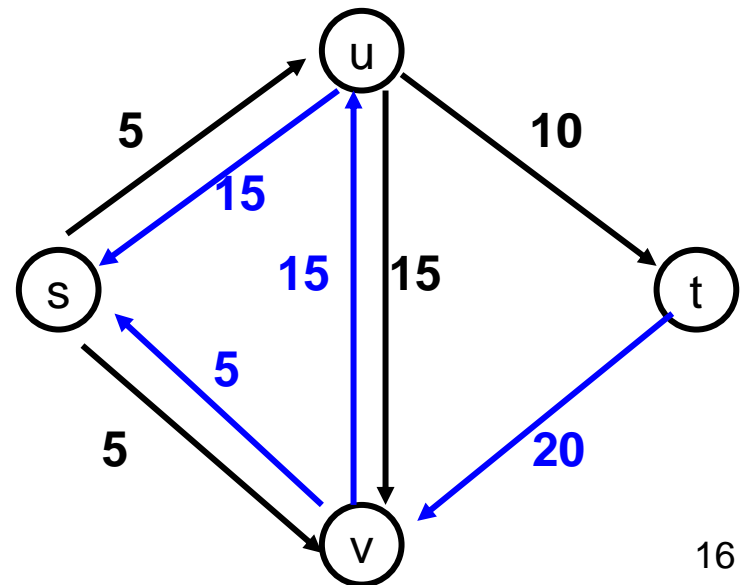
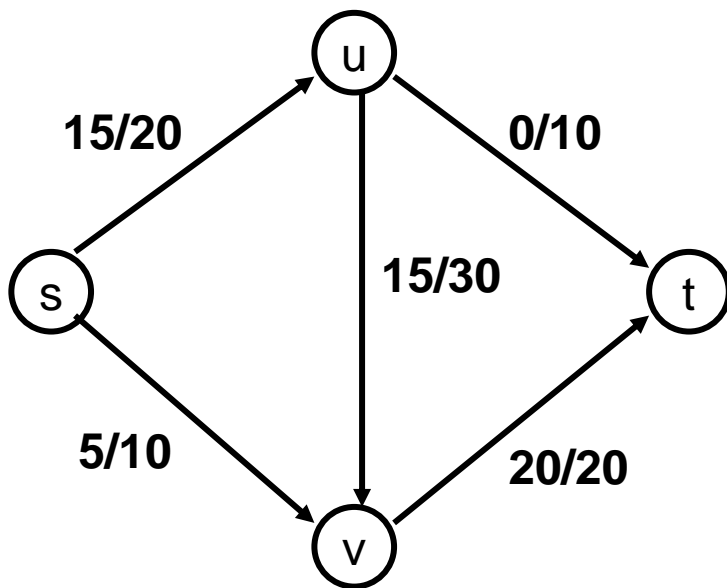

Proof

- Add b units of flow along the path P
- What do we need to verify to show we have a valid flow after we do this?

—

—

Ford-Fulkerson Algorithm (1956)

while not done

 Construct residual graph G_R

 Find an s-t path P in G_R with capacity $b > 0$

 Add b units along in G

If the sum of the capacities of edges leaving S is at most C , then the algorithm takes at most C iterations