



The Operation Of The Data Path

The data path implements the fetch execute cycle, fetching instructions, decoding, executing and incrementing the PC

Datapath Components

Abstract the datapath by its principal parts

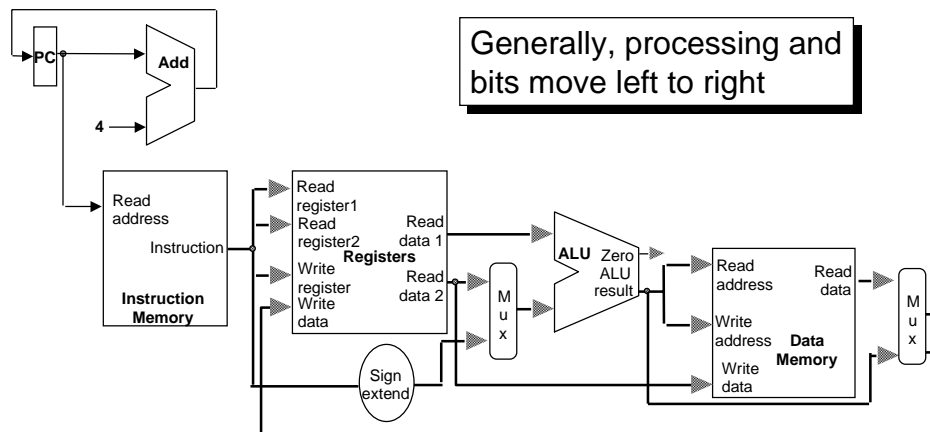

Fetching Instructions

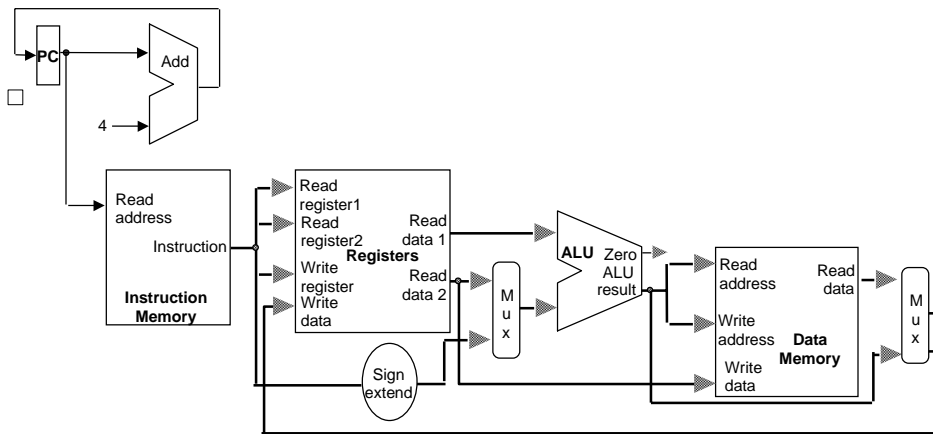

R-type Instructions

3 registers are referenced, 2 for reading, 1 for writing

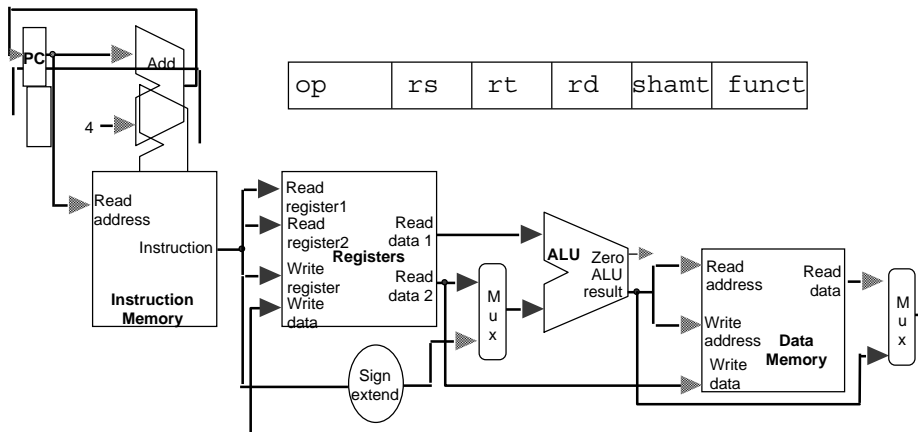

I-type Instructions

The immediate field must be sign extended

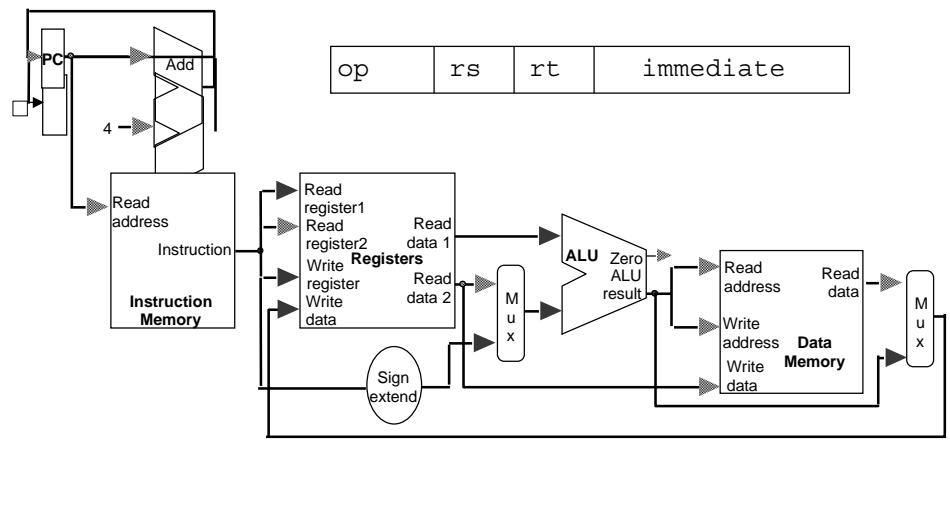

Load Instructions

ALU output references data memory

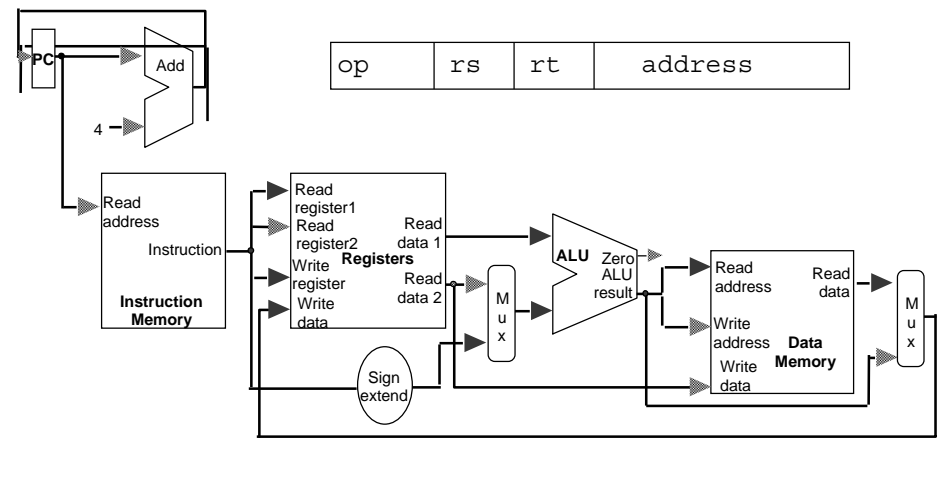

Store Instructions

Write-back is not required

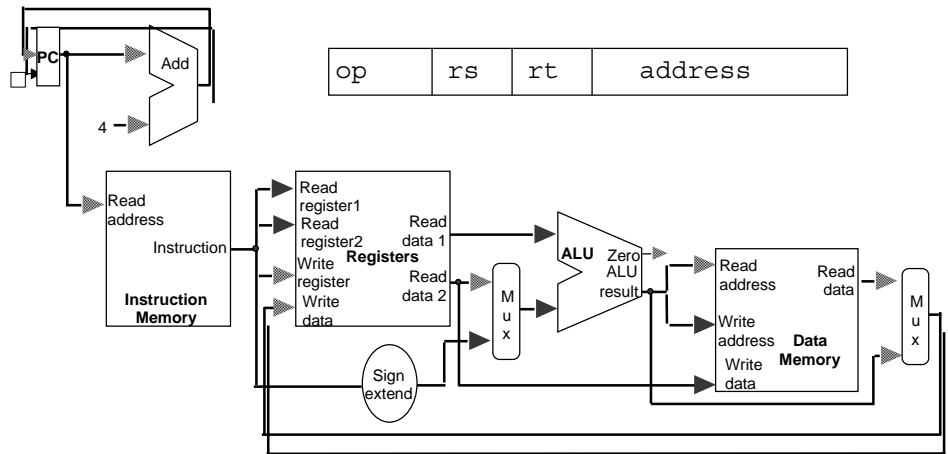

Branches

Test and compute effective address

